

***THE HYPERSONIC REVOLUTION***

***Case Studies in the History of Hypersonic Technology***

**Volume I**

**From Max Valier to Project PRIME  
(1924-1967)**

**Edited by  
Dr. Richard P. Hallion**

**With Contributions By**

**John Becker  
Ronald Boston  
Clarence Geiger  
Richard Hallion  
Robert Houston  
John Vitelli**

**Air Force History and Museums Program  
Bolling AFB, DC 20332-1111  
1998**

This study is dedicated to the memory of the crew of the Space Shuttle Challenger, Flight 51-L:

Francis R. Scobee	Mission Commander
Michael J. Smith	Pilot
Judith A. Resnik	Mission Specialist
Ellison A. Onizuka	Mission Specialist
Ronald E. McNair	Mission Specialist
Gregory B. Jarvis	Payload Specialist
S. Christa McAuliffe	Payload Specialist

". . . they are marked out not merely by the inscription over a grave in their own country but in other lands also by an unwritten memory, recording their spirit more than their actions, which lives on in the minds of men. Emulate them, then, in your own lives. . ."

--from the funeral oration of Pericles during the Peloponnesian War



VOLUME I

TABLE OF CONTENTS

<i>About this Series</i>	98-i
<i>Whither Hypersonics? A Foreword to the 1998 Edition</i> by Richard P. Hallion	98-iii
<i>Foreword to the 1987 Edition</i> by Richard P. Hallion	v
<i>Preface: In the Beginning Was the Dream: Hypersonics to the Dawn of the Space Age</i> by Richard P. Hallion	x
<i>Case I: Transiting from Air to Space: the North American X-15</i> by Robert S. Houston, Richard P. Hallion, and Ronald G. Boston	I-i
<i>Case II: Strangled Infant: The Boeing X-20A Dyna-Soar</i> by Clarence J. Geiger	II-i
<i>Case III: The Development of Winged Reentry Vehicles: An Essay from the NACA-NASA Perspective, 1952-1963</i> by John V. Becker	III-i
<i>Case IV: ASSET: Pioneer of Lifting Reentry</i> by Richard P. Hallion	IV-i
<i>Case V: Project PRIME: Hypersonic Reentry From Space</i> by John L. Vitelli, and Richard P. Hallion	V-i



### *About This Series*

*The Hypersonic Revolution* began as a study effort while I was Director of the Special Staff Office at the Aeronautical Systems Division of Air Force Systems Command (ASD, now the Aeronautical Systems Center of Air Force Materiel Command) at Wright-Patterson Air Force Base in 1986. At that time, coinciding with vigorous interest in developing what were then termed "Transatmospheric Vehicles" (TAV), I was convinced that the hypersonics field needed a solid grounding in its own history. Accordingly, I assembled and edited a two-volume group of studies by leading experts and authorities who had written on the major programs, and these were locally published by ASD in 1987. I planned a third volume as well, on the then-ongoing National Aero-Space Plane effort (NASP, which became the X-30 program), but recognized that it would have to be completed at a later date. Reaction to the first two volumes was immediate and strongly positive, as *The Hypersonic Revolution* constituted the first compilation of case studies on hypersonic technology ever assembled. It quickly became a much sought-after reference, and, I am gratified to say, has remained so to the present day, despite an obvious need to be brought more up-to-date.

That updating is at least partially addressed by the third volume, only now ready for publication. Understandably, it had a lengthier history for, after all, the X-30 NASP program itself was just unfolding. During my tenure at ASD, the leadership of the NASP joint program office (Brig. Gen. Kenneth Staten, who first established the JPO, and then his successor Dr. Robert Barthelemy) were both keenly interested in the history of hypersonics and strongly supportive of ensuring that the history of the NASP was appropriately documented. As a long-time student of high-speed flight in general and hypersonics in particular, I found their attitude and support most encouraging. In 1987 I left to teach at the Army War College on a one-year visiting professorship, and, the following year, joined Headquarters Air Force Systems Command, effectively ending any opportunity I might have had to continue at that time with the history of hypersonic flight (though I later briefly returned to the field

while serving as a senior issues and policy analyst in the Secretary of the Air Force's Staff Group during the exciting and productive tenure of Secretary Donald Rice).

But we were all fortunate that, at this time, another player entered the scene: Dr. Larry Schweikart of the University of Dayton. Schweikart, a distinguished student of national defense acquisition policy and programs, already knew Dr. Barthelemy, and exhibited keen interest in pursuing the history of NASP. Very quickly, the NASP Joint Program Office supported a contract for his research; ultimately, it proved long and, at times, tortuous; Schweikart was unflinching in his research and tenacity to get at the story. Thus, the third volume became a reality a decade after he began his work. Rather than publish the third volume as a "stand alone" work, the completion of this third volume now offers an opportunity to reissue the first two volumes as well, giving the aerospace community an opportunity to have a set of case studies in hypersonics even as once again there is rising interest in the subject.

It is worth noting that, since the time the first two volumes of *The Hypersonic Revolution* appeared, much more information has come to light regarding certain technology areas and activities, particularly (1) air-breathing propulsion development, and (2) the hypersonic and lifting reentry activities of the former Soviet Union. Accordingly, Volume II now has been given a short section on propulsion (added to the editor's introduction of the NASA HRE scramjet case study), and an appendix on Soviet hypersonics (added to the Epilogue) Further, I have added an introductory essay, "Whither Hypersonics?" briefly tracing and summarizing some of the recent history as well as the current state of hypersonic projects and work, so as to enable readers to place these volumes within a broader and more relevant context.

Dr. Richard P. Hallion  
The Air Force Historian  
HQ USAF/HO  
500 Duncan Avenue, Box 94  
Bolling AFB, DC 20332-1111

WHITHER HYPERSONICS?  
A FOREWORD TO THE 1998 EDITION

by  
Dr. Richard P. Hallion

The history of hypersonics teaches that faith in, and unquestioning acceptance of, a hypersonic future is akin to belief in the Second Coming: one knows and trusts that it *will* occur, but one can't be certain *when*. That hypersonics is yet again in a period of renewal echoes a familiar theme in the history of hypersonic research and development. As programs have waxed and waned, the field has progressed through various cycles of growing interest and rising optimism followed by cancellation, pessimism, and slow rebuilding of interest. For example, at the time the first two volumes of *The Hypersonic Revolution: Case Studies in the History of Hypersonic Technology* were published, it appeared that the field was, at last, on the verge of achieving what had been its most long-sought goal: developing hardware--a genuine transatmospheric vehicle, the X-30, that could take off from the earth under its own power (using air breathing propulsion) fly through the atmosphere into space, and then return through the atmosphere to land, and possible complementary European and Asian vehicles as well.

Unfortunately, such was not to be. Despite strong interest among partisans and sympathizers, broad-based support remained cool at best. First the foreign ventures folded, both the simple and the complex: France's *Hermes*, Britain's HOTOL, Germany's *Sanger II*, and Japan's *Hope*; the Soviet space shuttle *Buran* ("Snowflake") abruptly melted in the near-cataclysmic collapse of the USSR, and artifacts (including lifting reentry spacecraft) from a once-proud and seemingly invincible space program went on sale in the West. Then it was the turn of the X-30. In 1994, a variety of time-and-cost-consuming technological challenges (in part stemming from too-ambitious goals, namely achieving single-stage-to-orbit operation via a radical and unprecedented air-breathing propulsion approach, and,

overall, attempting to integrate too many new and unproven technologies at one swoop into an actual flying vehicle), coupled with declining support, finally caught up with and doomed the complex X-30 to the same fate as its almost-identically named *Aerospaceplane* predecessor three decades previously.

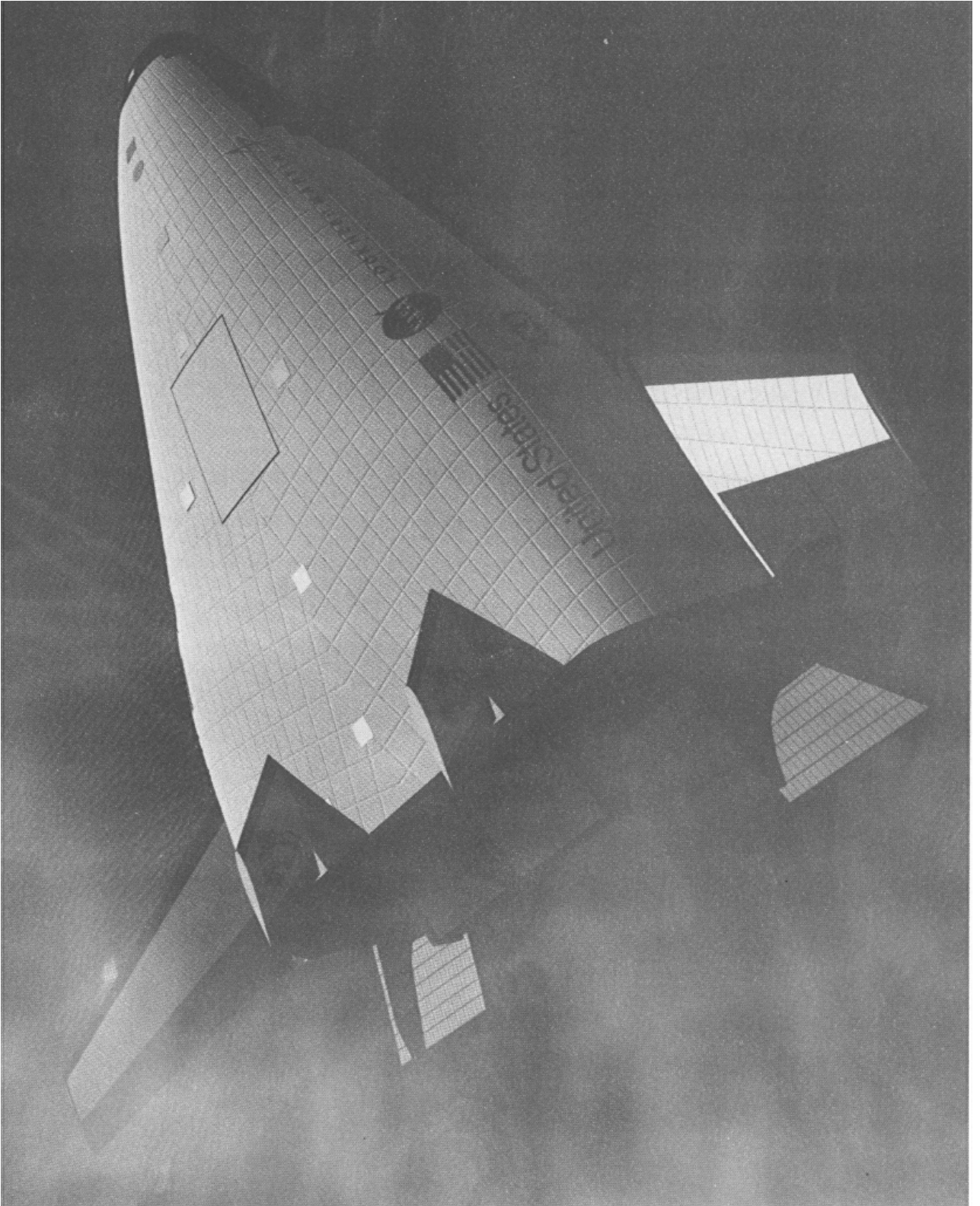
But the collapse of the X-30 also illuminated one of the encouraging traditions and characteristics of the hypersonics field: its remarkable resilience in the face of adversity. In fact, ironically, at the same time that the X-30 was foundering amid increasingly rough seas of controversy, other more low-key hypersonic study efforts were proceeding generally smoothly. So for the present hypersonics soldiers on and, akin to Robert Bruce's persistent spider, each program attempted has been a little bit more advanced than its predecessors, a little closer to fulfillment than those going before, offering hope to those who carry the torch for reusable hypersonic vehicles. Today, the American hypersonics field exhibits strong vitality, as a cursory review of current projects indicates. These range from small university laboratory hypervelocity tunnel test projects to intriguing government-supported flight research efforts such as the Pegasus Hypersonic Experiment (PHYSX) and the Hyper-X.

PHYSX is a surprisingly simple "opportunistic" test program piggybacking on a commercial satellite launch booster; it consists of an instrumented "glove" installed on the first-stage wing of an Orbital Sciences Corporation Pegasus rocket, to examine hypersonic aerodynamic transitions from laminar to turbulent flow at velocities up to Mach 8 and altitudes to 200,000 feet and then telemeter the data to a waiting ground station. (The Pegasus, a three-stage launch vehicle with a winged first stage, is air-launched like a rocket research airplane from either a modified Lockheed L-1011 jetliner or a Boeing B-52 mothership, and reaches nearly 5,600 mph (approximately Mach 8.4) in 77 seconds before the winged first stage burns out and the second stage fires).<sup>1</sup> Hyper-X (discussed more completely in the editor's introduction to the NASA HRE scramjet in Volume II) is a Mach 7-10 scramjet boosted to hypersonic speeds by a single-stage Pegasus booster air-launched from a NASA B-52 mothership, intended to examine and validate

scramjet design and performance.<sup>2</sup> Another hypersonic project is NASA's X-38, a rediscovery of a 1960's Air Force lifting body, the SV-5 (X-24A), the subject of case studies in both Volumes I and II.<sup>3</sup> The X-38 is potentially the forerunner of a lifting body crew rescue vehicle to be deployed from the International Space Station, a sort of "space lifeboat." Unlike the earlier SV-5, there is no intention of actually flying and landing the X-38 following a traditional low lift-to-drag ratio lifting body approach. Rather, the X-38 would undock from the Space Station, deorbit, and descend through the atmosphere automatically, decelerating to subsonic velocities, and then deploying a parafoil similar to (but more sophisticated than) the old Rogallo Parawing approach proposed in the Gemini era.<sup>4</sup>

Ambitious as these all are, they nevertheless are eclipsed by the boldness of NASA and the Air Force's major hypersonic space efforts, the most ambitious of which is the unpiloted twin-rocket-powered Lockheed Martin X-33 lifting body. Together, a triad of the X-33, the technical lessons learned from the recent DC-XA program, and the X-34 constitute the core of the national Reusable Launch Vehicle Technology Program, a NASA-Air Force-industry partnership to develop a new generation of single-stage-to-orbit vehicles. Flagship of this effort has been the suborbital X-33 testbed. The X-33 is a half-scale technology demonstrator prototype scheduled to fly in 1999, which may presage a 21<sup>st</sup> Century reusable launch vehicle (RLV) called the *VentureStar*, itself hopefully lowering the cost of orbiting a pound of payload by an order of magnitude, from today's \$10,000 to \$1,000 within ten years. Key to the X-33 is a radical Rocketdyne XRS-2200 linear aerospoke engine producing 202,000 lbs. thrust by burning a mixture of liquid hydrogen and liquid oxygen, itself a thirty-year-old idea offering lighter, less complex, and more powerful propulsion together with lower development risk compared to conventional rocket propulsion systems. On July 2, 1996, NASA selected Lockheed Martin's Skunk Works to design, build, and subsequently fly the X-33 test vehicle from a test site constructed on Haystack Butte, on the Edwards Air Force Base east of the famed dry lakebed. Much is expected in the future from the X-33, and time will tell if it is a worthy successor to previous efforts such as the

Figure 1



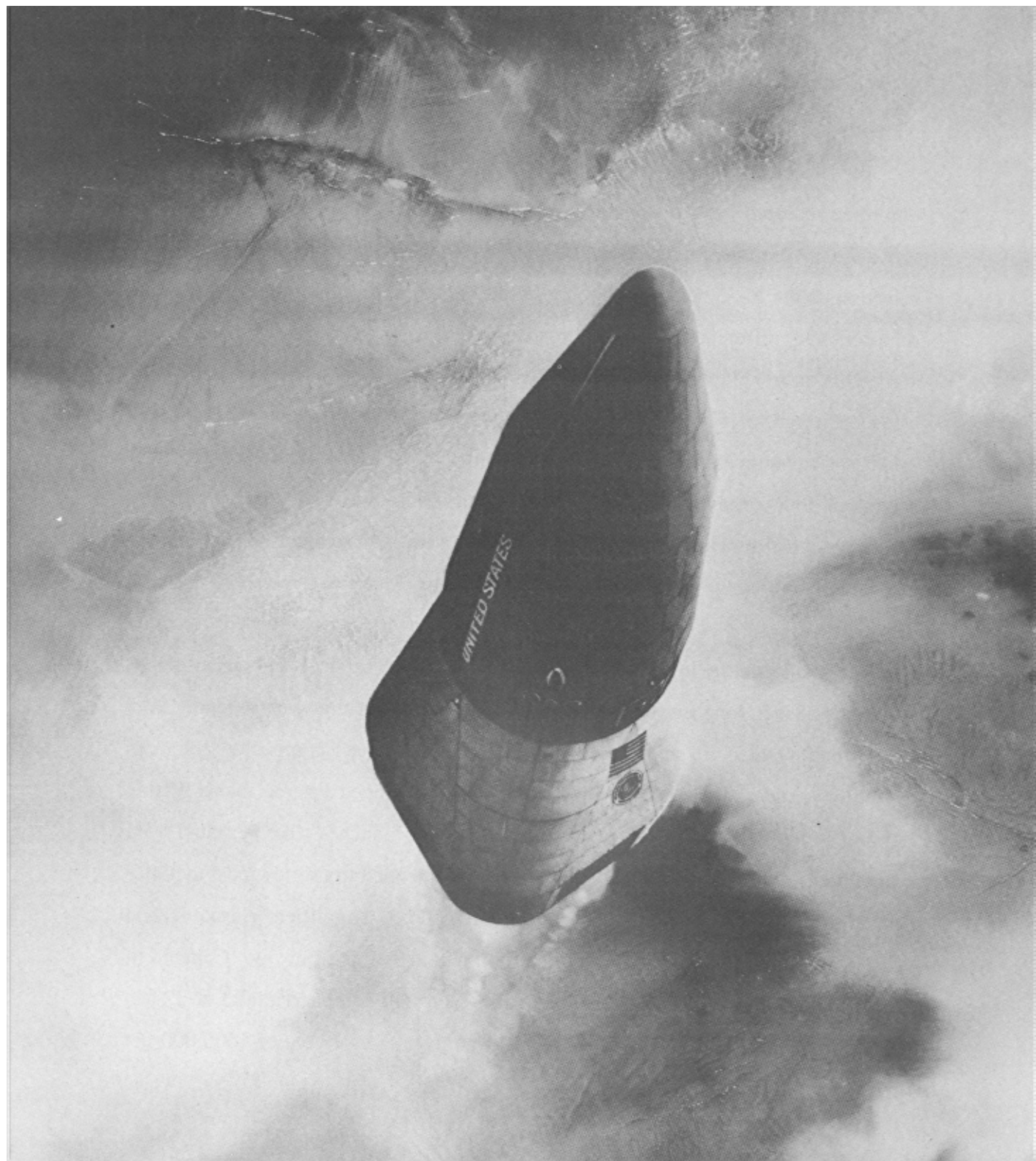
LOCKHEED-MARTIN X-33



X-15 and the Space Shuttle as well as the progenitor of *VentureStar*. Complementing it are other study efforts including planned upgrades to the Shuttle itself, and the Bantam X Project, a latter a study effort by NASA for imaginative off-the-shelf approaches to reducing reusable launch vehicle costs to about \$3,750 per pound placed in orbit.<sup>5</sup>

Intertwined with the development of the X-33/*VentureStar* have been two other unpiloted research programs: the now-abandoned McDonnell-Douglas DC-X/DC-XA *Clipper Graham* that once rivaled the Lockheed-Martin lifting body for selection as the X-33, and the ongoing Orbital Sciences Corporation X-34. These represent very different technical approaches; the former was a small subsonic (and somewhat tubby) blunt-conical-shaped 40 ft. high sophisticated guided missile with a loaded weight of 41,600 lbs, powered by four 13,500 lb. Pratt and Whitney RL-10A5 rocket engines burning a mix of liquid hydrogen and liquid oxygen, and relying on four aerodynamic body flaps and four 440 lb. thrust computer-controlled reaction control thrusters for stability and flight path management.<sup>6</sup> The latter is also small, but a far more conventional-appearing Mach 8 hypersonic testbed, drawing on both NASA thinking and Orbital's own lessons-learned from its Pegasus small satellite low-earth-orbit launch vehicle. The sleek and elegant X-34 features a 58.3 ft. long fuselage and sharply swept double-delta wing spanning 27.7 ft., a small vertical fin and horizontal body flap, advanced composite structures technology, and a single 60,000 lb. thrust NASA-developed Fastrac rocket engine burning a mixture of liquid oxygen and kerosene. Air-launched (like Pegasus) from a modified Lockheed L-1011 jetliner, the X-34 is intended to use low-cost avionics (including GPS positioning and inertial navigation), simplified checkout and vehicle monitoring systems, and then land on a conventional runway. Capable of Mach 8 flight speeds, under present plans the X-34 will complete a total of 27 test flights from multiple launch and recovery locations at a cost goal of \$500,000 per flight, possibly with a second X-34 flight test vehicle as well.<sup>7</sup>

Figure 2



McDONNELL-DOUGLAS DC-X DELTA CLIPPER

Figure 3



ORBITAL SCIENCES CORPORATION X-34

### *Hyper Reach, Hyper Power: Expectations of Military Hypersonics*

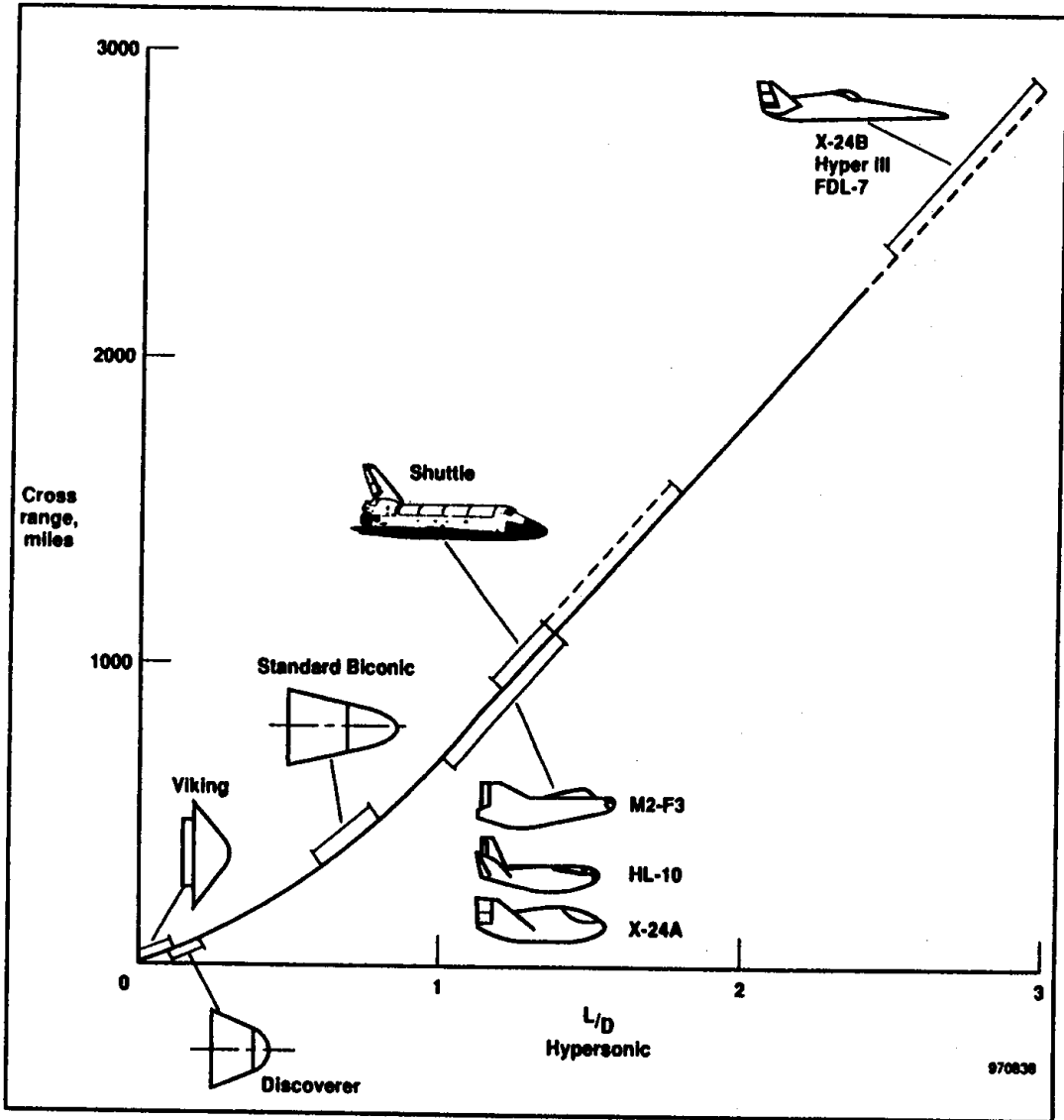
For approximately four decades, the hypersonic community had a difficult and somewhat dichotomous relationship with the military. Military officials concerned with force-structure requirements and combat operations recognized that hypersonics might have some merit, but the serious technological challenges (first involving rocket propulsion and reentry protection and then, over time, more complex challenges, particularly air-breathing propulsion), and the pressing needs to develop more conventional fighters, bombers, and missiles to confront a highly aggressive Soviet state, often encouraged deferring work on hypersonics in favor of a “replacement strategy” emphasizing developing more traditional kinds of aircraft, missile, and other weapon systems. This deferment, while somewhat understandable, not surprisingly spawned even further disinterest, so that, even as late as 1990, there was no real consensus or doctrine that supported a major military investment in hypersonic systems. In fact, significant splits opened between hypersonic advocates (typically drawn from the engineering and technology community within Air Force Systems Command), and the operational community (typified by the Strategic Air Command and Tactical Air Command). Ironically, operators tended to see hypersonics as too “space” oriented, while many in the pure space community were equally critical of hypersonics, seeing it as too “atmospheric” oriented! Indeed, in some quarters, there was a marked suspicion that money available to spend on hypersonics was, by definition, money that should be reallocated to other needs.<sup>8</sup>

This somewhat contradictory attitude of mixed interest and neglect prevailed throughout the Cold War, and persisted even into the post-Cold War world, at a time when hypersonics was far more practical and achievable than it had been in an earlier period. But over time, hypersonics became more attractive, thanks to achievement of some strong technical capabilities, for example, the development of maneuvering reentry vehicles for ballistic missiles, and the practical demonstration of hypersonic atmospheric entry by the Space Shuttle. The improvement over time

of cross-range due to hypersonic lift-to-drag ratios increasing from those attainable in the earliest days of the blunt-body-dominated space program (typically  $L/D \leq 1$ ) to those obtainable today with more modern aerodynamically efficient hypersonic vehicle concepts ( $L/D \cong 3$ ), indicated that modern hypersonic vehicle technology offered significant opportunities for global power projection. (See Figure 4) Further, both before and after the Gulf War, the growing ability to develop hypersonic weapons (whether conventional or nuclear-armed) for long-range standoff missions requiring rapid response over global distances promised to transform aerospace power projection.

But most of all it was the radical reshaping of the Air Force that accompanied the issuance of Secretary of the Air Force Donald B. Rice's landmark *Global Reach—Global Power* strategic planning framework in June 1990 acted powerfully to rejuvenate interest in hypersonics for long-range rapid crisis response. While this might have been seen as an encouragement for the NASP then undergoing its own developmental tribulations, in fact it spawned a great deal of interest in unpiloted hypersonic systems, and a search for piloted systems having a different focus or emphasis than the planned X-30. In July 1990, Colonel John Warden, the Deputy Director for Warfighting in the Headquarters U.S. Air Force Directorate of Plans (as well as a noted air power thinker soon to gain fame as the architect of the *Instant Thunder* campaign plan put forth at the onset of the Gulf Crisis), sponsored a wide-ranging conference to examine the state of hypersonic vehicle design, technology, and possible utility. Three months later, in October 1991, Dr. John Anderson, a noted civilian authority in the hypersonics area, organized a joint conference between the Smithsonian Institution and the University of Maryland (a noted center of hypersonic research and thinking) to assess one of the most attractive of hypersonic configurations, the elegant and sinuous waverider. Both these conferences stimulated a great deal of thought, as did the combat experience of *Operation Desert Storm*, which highlighted the value of precision attack together with indications that various hypersonic capabilities—strike and reconnaissance, for example—could have proven beneficial to coalition forces.

Figure 4



Graph showing cross range distances in miles plotted against hypersonic lift over drag for several vehicles returning from orbit. Notice that the "race-horse" vehicles such as the X-24B and Hyper III have the greatest cross-range capability—around 2,500 miles.

### HYPERSONIC L/D VS. CROSS RANGE FOR VARIOUS SHAPES

Source: Reed, p. 156

In the early-to-mid-1990's, a series of Air Force planning ventures explored hypersonic applications for a variety of mission areas and needs, including: *Spacecast* (by Air University); the RAND Corporation; *New World Vistas* (by the Air Force Scientific Advisory Board); the Center for Strategic and International Studies; and the Headquarters Air Force long-range planning staff which, under the direction of Maj. Gen. John Gordon (and later Maj. Gens. Robert Linhard and David McIlvoy) was establishing the planning background for the *Global Engagement* strategic planning framework that, in 1996, followed Rice's *Global Reach—Global Power* initiative of 1990. From all of these came a realization that hypersonics was achievable, exploitable, timely, and, above all, militarily desirable.

The most detailed technical analysis of the future potentialities of military hypersonics, by the Scientific Advisory Board, concluded in December 1995 that:

“Even with the tremendous increase in space operations in the future there will continue to be a major place for air breathing platforms/vehicles. Time is now, always has been, and even more so in the information age future, will be of the essence in military operations especially those of the Air Force. All distances on the earth are fixed. *If the Air Force is to execute faster than an enemy in the 21st century, then to reduce time, the only alternative is to go faster. Hypersonic air breathing flight is as natural as supersonic flight.* Advanced cycle, dual mode ramjet/scramjet engines and high temperature, lighter weight materials which allow for long range long endurance, high altitude supercruise are the enabling technologies.”<sup>9</sup> [Emphasis added]

The SAB investigation of hypersonics concluded that “Sustained hypersonic flight offers potential revolutionary improvements in future warfighting and space launch capabilities.”<sup>10</sup> A panel under the direction of chairman Dr. Richard Bradley (Director of Flight Sciences for the Lockheed-Martin Corporation)

identified four key hypersonic concepts including missiles, maneuvering reentry vehicles, a rapid response/global reach aircraft system, and a space launch/support system. The panel concluded that the Air Force would possess:<sup>11</sup>

--within a decade, the capability to develop small air-launched scramjet or ducted rocket-powered hypersonic cruise missiles capable of reaching Mach 8, having a range of several hundred miles against surface (or air) targets, and then impacting surface targets at up to Mach 5.

--within a decade, the capability of developing a Mach 20 boost-glide intercontinental or intermediate range ballistic missile-lofted hypersonic maneuvering reentry vehicle with a large footprint (measuring 3,000 mi. crossrange by 10,000 mile downrange), having a hypersonic lift-to-drag ratio (L/D) of 3 at Mach 20, and a Mach 6 impact on deeply buried targets.

--by 2010-2020, the ability to develop a rapid-response orbital scramjet-powered Mach 16-18 transatmospheric vehicle using a skip-glide approach *a la* Eugen Sanger and Irene Bredt, for force projection, recce/intel, or space payload insertion or staging; other smaller families of vehicles could be developed for Mach 6-8 missions over 8,000 miles burning advanced hydrocarbon fuels, or Mach 8-12 missions over a 10,000 mi. range burning hydrogen.

--by 2005-2020, the ability to design a reusable space launch vehicle using (in the short term) rocket propulsion or, by 2020, advanced air-breathing propulsion, to deliver up to 25,000 lbs. into low earth orbit at short notice.



Hypersonic vehicle technology offers high leverage against a variety of traditional Air Force mission areas, as well as some new and challenging ones, including countering weapons of mass destruction and mobile surface-to-air missiles, countering invading armies and suppressing hostile artillery, countering theater ballistic missiles, and countering cruise missiles. To accomplish this, however, will require a continued strong technological development effort, as Figures 5 and 6 clearly imply.

Critical to this will be the enhancement and support of a wide range of ground and flight test facilities. Here, unfortunately, the story is less encouraging; indeed, the Scientific Advisory Board *New World Vistas* study concluded in 1995 that:

“The gaps between facilities needs, facility availability and facility possibilities are greatest in the hypersonic speed regime. *Existing test facilities are grossly inadequate to support development of hypersonic vehicles for sustained flight within the atmosphere.* While extreme hypersonic test environments cannot be duplicated in test facilities, there are techniques and technologies to permit development of hypersonic test facilities much better than those that now exist. When one couples these observations with the expressed needs for hypersonic military systems, the urgency of some needed actions is evident. Major test capability cannot be acquired without lengthy efforts for facility planning, research, design, and construction. We know that it is not possible to await the arrival of a flight system development program to start the facility development and acquisition process. The ground test facilities started today will determine the major development capability available for the first two decades of the 21st century. The available test capability will, in

Figure 5

Table 2.6.2 Hypersonic Vehicle Technologies

Technology	Examples	Priority	Status
<b>Integration</b>			
Design Tools for Affordability	Cost Models: Vehicle, Manufacturing Process, Training, and Logistics Support	A	3
Vehicle and Manufacturing Process Design Methods	Design for Manufacturability; Multidisciplinary Design Optimization; Modeling and Simulation	A	2
Test and Evaluation	Integrated Test, Simulation, and Computational Analysis	B	2-3
<b>Aerodynamics</b>			
Advanced Configurations	Waverider/Body; Hypersonic L/D	B	2
Flow Control	Transition Control	B	3
Design Methods	Wind Tunnel Test Techniques; CFD	A	2
Facilities	Hypersonic Aero Facilities	A	2
<b>Airbreathing Propulsion</b>			
Combined Cycle Engines		A	2
Dual-Mode Ramjet/Scramjet		A	2-3
External Burning		C	2
Facilities	Realistic Test Conditions	A	2-3
<b>Structures</b>			
Advanced Airframe Materials	Metallics; Advanced Composites; Advanced Lightweight Materials	A	2
High-Temperature Airframe Materials	Hypersonic Airframes; Exhaust Impingement Structures	A	2
Adaptive Structures	Smart Materials; Active Load/Thermal Control	A	2
Configuration and Concept Design	Tailored Structures; Concurrent Design	A	2
Multi-Functional Structures	Health Monitoring and Diagnostics; "Smart Skins"	B	2
Facilities		A	2
<b>Vehicle Control</b>			
Integrated Control System Architecture	Autonomous Active Control of Flight, Avionics, Engines, Structure, and Subsystems; Flowfield; FBL/PBW	A	1
Human System Interface	External Vision; Displays; Integration with Off-Board Controllers	B	2
Multivariable Design Tools and Criteria	Multivariable Active Control; Cognitive Engineering-Based Criteria; Control Laws for Expanded-Envelope Flight	A	2
Fault Diagnostics and In-Flight Reconfiguration	In-Flight Aircraft Health Monitoring and Diagnostics; Automated Reconfigurable Controls	A	2
<b>Aircraft Subsystems</b>			
Thermal Energy Management	Component Life	A	2
Endothermic Fuels		A	2
Ground Operations	Takeoff and Landing Systems	A	2
Air Crew Escape	Aircrew Safety/Effectiveness	A	2

Key:

System Priority  
 A-Must Have  
 B-Enhances Performance/Cost  
 C-May be "Traded Out"

Facility Priority  
 A-New Are Needed  
 B-Major Upgrade  
 C-Existing Are OK

Technology Status  
 1-Potential Availability Now-5 Yrs  
 2- Potential Availability 5-15 Yrs  
 3- Potential Availability 15+ Yrs

STATUS OF TECHNOLOGIES REQUIRED FOR HYPERSONIC VEHICLE DESIGN

Figure 6

Source: New World Vistas (1995)

Table 2.6.1 Technologies and Associated Mach Number Range

	Missiles (Accelerators)	Maneuvering Reentry Vehicles (Accelerators)	Rapid Response/ Global Reach Aircraft Systems (Cruisers)	Space Launch Support (Accelerators)
Mach Number	1-6	0-20	0-18	0-25
Enabling Technologies				
Aerodynamics	-High Lift/Drag Ratio -Low Drag -Airframe- Propulsion Integration -Controls	-High Lift/Drag -Minimal Aero Heating -Flow Modification	-Low Drag -Airframe-Prop Integration -High L/D -Control Effectiveness -Flow Modification	-Low Drag -Airframe-Prop Integration -Low Aero Heating -Control Effectiveness -Flow Modification
Propulsion	-Rocket -Dual-Mode Ramjet/Scramjet	-Rocket	-Rocket -Combined Cycle -Dual-Mode Ramjet/Scramjet -External Burning	-Rocket -Combined Cycle -Dual-Mode Ramjet/Scramjet -External Burning
Fuels	-Hydrocarbon -Endothermic HC		-Hydrocarbon -Endothermic HC -Hydrogen	-Hydrocarbon -Endothermic HC -Hydrogen
Structures	-Heat Sink -Ablatives	-Thermal Protection -Radiation Cooled	-Fuel Cooled -Radiation Cooled -Long Life Structure	-Fuel Cooled -Radiation Cooled -Low Structural Weight Fraction

TECHNOLOGIES REQUIRED BY VEHICLE TYPE

turn, determine the opportunities for development of hypersonic flight systems.”<sup>12</sup> [Emphasis added]

The early history—into the 1960’s—of facilities development for hypersonics testing is subsequently discussed in the author’s preface to Volume I of this study. Ironically, at the time it was written—1986—it appeared that the stimulus of the NASP program would reinvigorate American hypersonic facilities development. Such, unfortunately, was not the case, in part because the program moved so rapidly that it outpaced any reasonable development cycle for comprehensive ground test and simulation facilities. As a result, the hypersonic facilities situation, in fact, is little changed in capability *from* the 1960’s, and, in some cases, *worse*, for some of the facilities developed at that time have since been closed or turned to other uses. It is this facilities challenge, in fact, that is arguably the most serious facing the hypersonic community today; there is bitter irony in that hypersonic facilities development has seriously lagged over the last three decades, even as interest in the field has noticeably accelerated.

For example, in three key areas of research (aerodynamic/aerothermal/aero-optics; structures; and aeropropulsion), ground test facilities are adequate for the lowest speed ranges, but very quickly are limited or inadequate for higher speed ranges. In aeropropulsion, facilities for combustion, engine, and engine-airframe integration testing are inadequate across virtually the entire range of Mach numbers of interest to researchers. Figure 7 indicates the kinds of test facilities required for various forms of hypersonic testing, as well as the challenge of dealing with test times measured not in the minutes or, at worst, seconds available to traditional wind tunnel researchers, but in milliseconds. The weaknesses in American hypersonic ground test facility capabilities have been the subject of continuing concern by a variety of engineering and scientific organizations, including the multiagency National Facilities Study, the National Research Council, and, most exhaustively, by the Air Force’s own Arnold Engineering Development Center, and will undoubtedly be a source of continuing concern, at least in the short-term.<sup>13</sup>

Figure 7

Table 4.1.1 Facility Capability Required to Adequately Test Emerging Hypersonic Systems

Type of Test	Critical Phenomena	Test Parameter		Test Time
		Duplicate	Relax	
Aerodynamic/ Aero-Optics				
Perfect Gas	Boundary Layer Transition Turbulence Flow Separation	Mach Reynolds No.	Temperature Velocity	Milliseconds
Real Gas	Chemically Reacting Flows	Gas Composition Velocity Temperature Density Scale	Run Time Density or Scale for Binary Reactions	Milliseconds
Aerothermal	Heating Rates and Aero-Shear Ablation	Total Temperature Surface Pressure Size	Mach No. for Stagnation Point Heating	Seconds- Minutes
Aeropropulsion	Chemical Reaction, Mixing, Boundary Layers & Shocks Full-size Hardware	Gas Composition Pressure Temperature Velocity Size		Milliseconds
Structure & Materials	Combined Loads (Mechanical, Thermal, Acoustics) Temperature Gradients	Gas Composition Pressure Velocity Geometry		Milliseconds

Source: SAB New World Vistas (1995)

As this enumeration of contemporary work clearly indicates, the disappointments and frustrations of the past have, if anything, driven and stimulated hypersonic partisans to greater effort, and out of this has come a better sense and rationale for why hypersonics is important and what it offers both commercially and militarily. From this have come greater levels of agency interest and support within the civilian and military sectors, reflected in increasingly practical and attainable projects that now offer new levels of achievement and capability. All of this represents a surprising and refreshingly optimistic result from a history that has been characterized both by great innovative success and, at times, profound frustration. Clearly, then, despite all its challenges, the field of hypersonics undoubtedly will remain one of extraordinary fascination to aerospace practitioners, analysts, and historians alike. In addition to commemorating the work of some remarkable individuals and documenting some extraordinary research and development efforts, these three volumes are furnished in the spirit that they will encourage further thought, reflection, and discussion within the hypersonic community with a view to fulfilling the vision of a hypersonic revolution that--for so long--has occupied some of the best minds this century of flight has produced.

---

## NOTES

<sup>1</sup>NASA Dryden Flight Research Center, "Pegasus Hypersonic Experiment Set to Fly," *The X-Press* (June 19, 1998), p. 4.

<sup>2</sup> Gray Creech, "Hyper-X Takes New Approach," *the X-Press* (Feb. 21, 1997), pp. 1, 3.

<sup>3</sup> The following discussion is based on information in: NASA Dryden Flight Research Center news release 98-10, "X-38 Atmospheric Vehicle Completes First Unpiloted Flight Test," 12 March 1998; NASA DFRC, "X-38 Technology," at:

<http://www.dfrc.nasa.gov/Projects/X38/index.html>

See also R. Dale Reed's excellent *Wingless Flight: The Lifting Body Story*, a volume in the *NASA History Series*, SP-4220 (Washington, D.C.: National Aeronautics and Space Administration, 1997), pp. 186-191. A gifted engineer, Reed was, incidentally, a key figure in the history of lifting body development, from the earliest days prior to the M2-F1 through the X-38 today.

<sup>4</sup> The X-38 has had an interesting history. In late 1986, the Langley Research Center's Vehicle Analysis Branch, inspired by the Soviet Union's BOR-4 hypersonic lifting body tested in the early 1980's, "reverse engineered" its configuration and proposed this "Americanized" derivative, the HL-20, as a crew rescue vehicle for future space station operations. Though Langley fabricated a mockup, NASA opted instead to adopt a Johnson Space Center suggestion to use the X-24A body shape; the resulting test vehicle received the X-38 designation. JSC began its studies in 1995, viewing the three-decade-old lifting body shape as a means of replacing the modified *Soyuz* spacecraft intended as the initial international space station crew rescue vehicle with a larger and more suitable design capable of accommodating up to seven passengers. In 1996, NASA contracted with Burt Rutan's Scaled Composites, Inc. (manufacturers of the *Voyager*, the world's first airplane to circle the globe nonstop, and other almost equally exotic craft) for a full-scale drop test demonstrator. Rutan delivered the first of three X-38's to JSC in September 1996. On March 12, 1998, the X-38 completed its first atmospheric drop test, being air-dropped from a B-52 mothership at 23,000 feet. Within seconds, its parafoil deployed, and the lifting body descended gently to earth, a propitious beginning. The drop height will increase to 50,000 feet and longer "clean" descent times prior to deployment of the parafoil, and, in the year 2000, NASA is planning an orbital flight test, deploying an unpiloted X-38 from a Space Shuttle. If all goes well, the X-38 crew rescue vehicle will be operational with the International Space Station in 2003. For the HL-20 side of the story, see James R. Asker, "NASA Design for Manned Spacecraft Draws on Soviet Subscale Spaceplane," *Aviation Week and Space Technology* (24 Sep. 1990), p. 28; and Robert A. Rivers, E. Bruce Jackson, and W. A. Ragsdale, "Piloted Simulator Studies of the HL-20 Lifting Body," *Society of Experimental Test Pilots, 1991 Report to the Aerospace Profession: Thirty-fifth Symposium Proceedings* (Lancaster, CA: SETP, 1991), pp. 44-59.

<sup>5</sup> Todd Halvorson, "Skunk Works Win X-33," *Florida Today*, July 2, 1996; NASA news releases FS 1997-01-0001-MSFC, "Linear Aerospoke Engine—Propulsion for the X-33 Vehicle," Jan. 1997, and FS-1997-05-003-MSFC, "X-33 Advanced Technology Demonstrator to Fly in 1999," May 1997; Lockheed Martin, "The Aerospoke Engine for the Reusable Launch Vehicle," n.d.; R. A. O'Leary and J. E. Beck, "Nozzle Design," *Threshold: An Engineering Journal of Power Technology*, 8 (Spring 1992), pp. 34-43; and Chris Erickson, "Power Cycle Selection in Aerospoke Engines for Single-Stage-to-Orbit (SSTO) Applications," Paper 97-3316, (Reston, VA: American Institute of Aeronautics and Astronautics, 1997); statement of Richard Christiansen, the Acting Associate Administrator for Aeronautics and Space Transportation Technology, NASA, before the Subcommittee on Space and Aeronautics, Committee on Science, U.S. House of Representatives, 12 Feb. 1998. The Bantam-X project began in November 1997, with study contracts awarded to Aerojet, Universal Space Lines, Summa Technologies, and Pioneer Rocketplane;

---

NASA Kennedy Space Center news release C97-e, "NASA Selects Four Companies to Demonstrate Low Cost Launch System Technologies," 9 June 1997.

“BMDO, “DC-X Fact Sheet,” n.d., from BMDOLink, as well as the NASA History Office’s DC-X and DC-XA flight testing archives, which may be accessed at:

<http://www.hq.nasa.gov/office/pao/History/x-33/dc-xa.htm>

The best overall account of the DC-X/DC-XA program is the late G. Harry Stine’s excellent and provocative memoir/history, *Halfway to Anywhere: Achieving America’s Destiny in Space* (New York: M. Evans and Company, Inc., 1996). I am grateful to the late Mr. Stine—a noted authority and pioneer of rocketry and astronautics, who wrote of DC-X type vehicles as far back as four decades ago—for making this work available to me. I also wish to acknowledge contributions to my thinking and understanding of the *Delta Clipper* program and its potentialities by Lt. Col. William “Burners” Bruner, USAF.

Though not strictly speaking a classic hypersonic program, the recently concluded DC-X/DC-XA *Clipper Graham* has played such an integral role in NASA and the Air Force’s future space launch thinking that it merits some discussion. The DC-X/DC-XA (an abbreviation of *Delta Clipper-Experimental*, though also an allusion to the legendary Douglas DC-3 airliner of the 1930’s, the first practicable profit-making airliner in aviation history), began in 1990 as the SSX (for Spaceship Experimental), a vertical takeoff-and-landing technology demonstration program of the Department of Defense’s Ballistic Missile Defense Organization (BMDO). The program subsequently diverged into two complementary efforts, one to explore a means of orbiting payloads using vertical launch and recovery, and the other to examine the military potentialities of suborbital reusable launch vehicles. The program emphasized cheap, reliable, and simplified operations, and blended a conventional metallic structure with advanced graphite epoxy and silicone-based construction concepts. Designers relied on off-the-shelf electronic flight control technology from the F-15 and F/A-18 fighter programs, together with Global Positioning System (GPS) satellite navigation referencing, and highly automated ground checkout and support facilities. The resulting “spacecraft” was an approximately one-third scale testbed of a proposed full-scale orbital vehicle. As the concept evolved, the vertical up-and-down approach of the *Delta Clipper* was in direct competition for the X-33 contract with the more traditional winged lifting reentry approach favored by traditionalists.

The DC-X made its first flight on August 18, 1993, at the U.S. Army’s White Sands Missile Range, completing a further six by mid-summer 1995. In mid-program, after its third flight, BMDO had decided against proceeding further with the full-scale program; results nevertheless had been so encouraging that additional Air Force funding enabled follow-on flight tests. On its fifth flight, June 27, 1994, the hardy DC-X survived an inflight hydrogen explosion immediately after takeoff, weathering the blast and landing automatically; after repairs, it took to the air again on May 16. On its eighth flight, July 7, 1995, it climbed to 8,200 feet, pitched over to a 10 deg. below-the-horizon attitude (simulating a reentering spacecraft), and then flawlessly executed a 138 deg. pitchup to a tail-first landing attitude, a significant milestone in the history of spaceflight technology. Though it landed successfully, high impact loads cracked its external shell, bringing its flight test career to a halt.

But like a phoenix, the DC-X underwent a rebirth. Rebuilt as the DC-XA (for *Delta Clipper-Experimental Advanced*), the craft now had a graphite epoxy hydrogen tank—the first composite hydrogen tank ever flown—that reduced vehicle weight by 1,200 lbs (compared to the original aluminum tank) as well as a new Russian-built aluminum-lithium liquid oxygen tank), and improvements to its reaction control system. The DC-XA, (renamed *Clipper Graham*, in honor of Lt. Gen. Daniel O. Graham, USA ret., who had been a tireless champion of the Strategic Defense Initiative up to the time of his death in December 1995) arrived back at White Sands on March 15, 1996, and made its first flight just over two months later, on May 18. Due to a slow landing approach, the vehicle overheated and experienced a small fire on the craft’s external skin, damaging a body flap. After repairs it returned to the air on June 7, demonstrating reliance on GPS-cued positioning; on its third flight, June 8, it soared to over 10,000 feet, remaining aloft for 2 minutes 22 seconds, the program’s altitude and duration record. Disaster struck on the fourth flight, when, after a flawless flight, one of its four landing gear struts failed to deploy; not surprisingly, the vehicle tipped over on landing, caught fire, and experienced severe damage. That was it; NASA could not afford to repair the little testbed, and, since Lockheed Martin had won the X-33 contract with a more traditional lifting body approach, there was little support for continuing the program in any case. The DC-X/DC-XA went into the history books, though, irrespective of the outcome of this program and the selection of a



---

lifting body planform for the X-33, there is undoubtedly continuing great merit in exploring the DC-XA kind of technical approach for both future commercial and military purposes.

<sup>7</sup> NASA news releases 97-043, "NASA, Department of Defense Team Up for X-34 Program," 15 Apr. 1997, and 97-107, "X-34 Systems Design Freeze Completed," 22 May 1997; Christiansen statement.

<sup>8</sup> As the author well remembers from surveying the state of hypersonics for Secretary Donald Rice, while serving as a Senior Issues and Policy Analyst on the Secretary's Staff Group in 1990-1991.

<sup>9</sup> USAF SAB, *New World Vistas: Air and Space Power for the 21<sup>st</sup> Century* (Washington, D.C.: USAF, 1995), *Summary* volume, p. 60. Hereafter *NWV* followed by volume name and page.

<sup>10</sup> *NWV, Aircraft and Propulsion*, p. 28.

<sup>11</sup> *Ibid.*, pp. 29-31.

<sup>12</sup> *Ibid.*, p. 97.

<sup>13</sup> *Ibid.*, p. 96. See also Arnold Engineering Development Center, *Hypersonic Test Investment Plan (HTIP): A Development Plan and Investment Strategy for U.S. Hypersonic Test Capabilities and Facilities*, Report AEDC-TR-94-4 (Tullahoma, TN: AEDC, 1994).



## FOREWORD

The hypersonic revolution has been a particularly American one, borne of the national pursuit of transonic and supersonic flight technology. True, it does have both domestic and international dimensions, in the prophecy of Robert Goddard, Hermann Oberth, and Konstantin Tsiolkovskiy at the beginning of the twentieth century, and in the prescient (if impractical) studies of Eugen Sänger and Irene Bredt (later Irene Sänger-Bredt) near mid-century. But if its inspiration was sometimes international in flavor, its execution was American--from the early pre-X-15 studies of the 1950's through the pioneering missions of Columbia in 1981. Primarily, the hypersonic revolution grew out of the traditional federal-industrial partnership that had benefitted American aviation since the First World War. It germinated and flourished amidst the laboratories of the Air Force, Navy, the National Advisory Committee for Aeronautics (NACA), and its successor, the National Aeronautics and Space Administration (NASA), and the major aerospace manufacturers. Not merely an aerodynamic revolution, the hypersonic revolution--like the supersonic breakthrough and the drive for the "modern" airplane before it--involved the creative integration and exploitation of diverse technologies, including structures, propulsion, aerodynamics, and controls. The aerospace community and the scientific and technological community at large are only now beginning to realize the significance and potential impact of this revolution, in the era of the Space Shuttle and the (hopefully) emerging National Aero-Space Plane (NASP).

These eight case studies--in two volumes--constitute an attempt to cut through the tangled web of hypersonic history and offer up some historical perspective and lessons. They have been chosen because they represent different facets of hypersonic

research and development. Some were modest unmanned vehicles, others ambitious manned programs. One was an experimental powerplant of a kind (though not specific type) expected to play a major role in the upcoming NASP. Some succeeded brilliantly. Others--fortunately a few--were disappointments. One, the X-20 Dyna-Soar--never had a chance to perform: it died not from technical insufficiency but from political disfavor. Yet all expanded the hypersonic data base, and all contributed (to a greater or lesser degree) to that supreme moment in April 1981 when Columbia thundered aloft from Kennedy Space Center on its historic first flight.

Students of management, succeeding generations of engineers, and historians often fall victim to the common malady of interpreting the past and the behavior of organizations and programs from a framework of post hoc coherence and rationality that is usually, in fact, absent at the time that actual decisions are being reached. Hindsight offers a charming and misleading clarity that too often results in perceptions of causality and analysis of management actions that are, at best, simplistic, and at worst, totally misleading. Instead, what needs to be constantly emphasized is that research and development most frequently occurs in an experimental, adaptive, and learning environment that is inherent in dynamic organizations, especially those that deal with science and technology. The best of such organizations tend not to be governed by power politics, cold rationality, or the organizational culture in which they exist, though these may play occasional roles. The organizations that promulgated the hypersonic revolution successfully brought it to fruition because their members were able to deal with complex management in a rapidly transforming environment; they neither waited for miracles, blindly followed dogmatic and rigid leadership, or timidly extrapolated from previous experience. At

the same time, they were organizations confronting many other challenges aside from those of hypersonic flight, and faced occasional setbacks (as evidenced in one case by the X-20 story) triggered by the external environment, as well as others (such as the NASA Hypersonic Ramjet Experiment) that stemmed from overoptimistic assumptions within the R and D organization itself. In reading these studies, the reader is cautioned to keep in mind two maxims of technological history: trend is not destiny, and correlation is not causation. Fortunately, the authors of these studies themselves have tended to present the stories in all their complexity--a complexity that the modern technological decision-maker can well appreciate given the difficult conditions under which research, development, test, evaluation, and acquisition occur today.

The authors of these studies are a diverse group of individuals including historians of technology, two military officers engaged in R and D, and a distinguished physicist. All have detailed knowledge of the field, and each has written a study on a particular area of personal expertise and interest. I have been privileged and fortunate to have worked with several of the authors, and now am honored to have the opportunity to draw together these works for the benefit of historians, decision-makers, and, most importantly, for the members of the hypersonic community. Each case study is identified separately according to subject and author(s). Previously, some of these studies appeared as special study monographs or individual research efforts. Now they have been incorporated together with new works into a single (and hopefully seminal) source document, with (as appropriate) revisions, expansions, and clarifications. There has been no attempt to change the viewpoints and conclusions of these studies to fit some general "viewpoint" of the hypersonic revolution. Rather, each author speaks with refreshing candor, in

the spirit of assisting the reader in avoiding the terrible dictum George Santayana expressed in his The Life of Reason: "Progress, far from consisting in change, depends on retentiveness. . . Those who cannot remember the past are condemned to repeat it".

Naturally, a document of this sort requires the advice and assistance of a wide body of individuals. I wish to thank all of them, and to acknowledge for the reader's benefit that they bear no responsibility for the conclusions and views presented herein. Rather, that is the responsibility of the individual authors. As editor (and occasional author) I assume overall responsibility for the final product. I do wish to acknowledge the very helpful assistance of a distinguished group of participants in the hypersonic story, notably: Dr John Anderson; Johnny Armstrong; Neil Armstrong; Dr Jerry Arnett; John Becker; Paul Bikle; Frank Boensch; Dave Brown; the late Dr Irene Sanger-Bredt; Maj Gen Michael Collins, USAF (retired); Charles Cosenza; A. Scott Crossfield; Alfred Draper; Col D.A. Dreesbach, USAF; Max Faget; Dr William Heiser; Robert Hoey; William "Pete" Knight; Jack Kolf; Ezra Kotcher; William Lamar; John Manke; John McTigue; Bruce Peterson; Lt Col Vince Rausch, USAF; Robert Salkeld; Col Curtis Scoville, USAF (retired); Leon Schindel; the late John Stack; Brig Gen Kenneth Staten, USAF; Frank Stull; Clarence Syvertson; Milton Thompson; Paul Waltrup; John Wesesky; A. Miles Whitnah; and Lt Col Ted Wierzbanowski, USAF.

I owe a special debt of gratitude to the following for their assistance to my research: Jean Anderson; Betty Chadwick; Ed Collins; Dr David Compton; Frederick C. Durant III; the late Dr Eugene Emme; Dr Edward Ezell; Dr Sylvia Fries; the late Sally Gates; Pat Gladson; Debbie Griggs; Jim Grimwood; Ralph Jackson; Dr Dick Kohn; Janet Kovacevich; Barbara Luxenberg; Jay Miller; Maj Gen Peter "Peet" Odgers, USAF (retired); Dr-Ing Walter Rathjen; Mildred Ruda; Lee Saegesser; Prof Richard Thomas; and Dr-Ing Injas

Widjaja. I wish to extend a special note of appreciation to Lt Col William "Flaps" Flanagan, USAF. Finally, I wish to thank my colleagues in the aerospace history and analysis field who have been particularly fruitful commentators, notably Dr Roger Bilstein, Dr Joe Guilmartin, Dr John Logsdon, Dr John Mauer, Dr Jim Young, Scott Pace, Curtis Peebles, and Robert Perry.

Richard P. Hallion  
ASD Special Staff Office  
Wright-Patterson AFB

1 June 1987

PREFACE

IN THE BEGINNING WAS THE DREAM. . .

by

Richard P. Hallion



The hypersonic revolution predates the beginning of the twentieth century. During the mid-nineteenth century, at a time when the word "hypersonic"\* was still a creation of the future, space futurists such as Charles G. Lightly, Werner von Siemens, and Hermann Ganswindt all prophesized creation of reaction-powered aircraft. Though these individuals had little real appreciation of the requirements of such craft, their doodlings and sketches may be properly considered as theoretical antecedents of the hypersonic projects that followed in the twentieth century. In 1903, Konstantin Tsiolkovskiy, a Russian school teacher, published an article forecasting the eventual development of rocket-propelled space vehicles. Slightly later, the American Robert H. Goddard, the father of the liquid-fuel rocket, independently reached similar conclusions, as did the Rumanian Hermann Oberth, about the time of the First World War. These three men, generally considered (in the words of rocketry pioneer and historian G. Edward Pendray) "the three great progenitors of the modern space age", were followed by a host of individuals who focused on specific problems and technical questions. One of these early spaceflight advocates, German rocket enthusiast Max Valier, believed that the manned spaceship would evolve from the

\*"hypersonic" refers to flight at speeds above Mach 5 - five times the speed of sound. As related to Raymond Seeger of the Naval Ordnance Laboratory by former Nazi aerodynamicist Hermann Kurzweg, the term hypersonic is American in origin, being a translation of superschall, a term for hypersonic flight as differentiated from uberschall, the term commonly used in wartime years for supersonic flight. (Seeger, "Reminiscences of the Beginnings of Aeroballistic Research at NOL," 4 Sep 1969, p. 2; copy transmitted to author by Leon H. Schindel). "Mach" number (after Austrian physicist Ernst Mach) refers to the speed of an object divided by the local speed of sound (which varies with height). Thus, an airplane flying at the speed of sound is moving at Mach 1. If it is moving twice the speed of sound it is flying at Mach 2, etc.

all-metal airplane. For experience, Valier suggested that, at first, rockets be added to conventional airplanes such as the Junkers G-23 transport. Later, designers could add more rockets and reduce the craft's wingspan. Finally, an entirely new design would be undertaken, one with six rocket engines (three in each short-span wing) and a pressurized cabin. Capable of high-speed flight into the stratosphere, this latter craft, he believed, could lead to intercontinental rocket-propelled airliners. Beyond this, Valier rejected winged configurations in favor of the ballistic rocket. In conjunction with Fritz von Opel and Alexander Lippisch, Valier conducted actual rocket-propelled glider experiments in 1928-1929, but his research ended with his death in a laboratory accident in 1930, when an experimental rocket engine exploded on a test stand, and shrapnel severed his aorta<sup>1</sup>.

In 1925, two years after Oberth published his classic treatise Die Rakete zu den Planetenraumen (The Rocket into Planetary Space), and a year after Valier first gained attention with his book Der Vorstoss in den Weltenraum (The Advance into Space), Walter Hohmann, a German civil engineer, published Die Erreichbarkeit der Himmelskörper (The Attainability of Celestial Bodies). Whereas previous writers had considered the problem of spaceflight in general, Hohmann examined one aspect in particular: the derivation of optimum transfer trajectories for flights from the earth to other planets. (The term "Hohmann Transfer" is now generally accepted world-wide). Hohmann also examined the problem of returning to earth, recognizing the value of using deceleration devices, and considering the related problem of aerodynamic heating. He theoretically examined the air drag forces acting on a reentering spacecraft at altitudes of 75 to 100 km. Though not per se concerned with the technology of reentry but rather with its mechanics, Hohmann, nevertheless, thought that returning

spacecraft should use parachute-like brakes or perhaps variable-incidence wings. His research predated later ballistic and lifting reentry studies, but sadly, he himself failed to see the fruition of his work, for his health deteriorated rapidly from overwork during the Second World War, and he died in 1945 at the age of 64<sup>2</sup>.

The work of Oberth, Valier, and Hohmann inspired Eugen Sänger, a young Viennese engineer, to undertake his own studies of rocketry and spaceflight, and he became the first major figure to advocate a Space Shuttle-type vehicle as it is now envisioned. Sänger conceived of such a spacecraft while a doctoral candidate at the Technische Hochschule of Vienna in 1929. He proposed examining the possibility of developing a winged spacecraft that would boost into earth orbit and rendezvous with a space station, followed by reentry and a glider-like descent to landing. His instructors suggested a more traditional doctoral thesis instead, and Sänger received his doctorate for studying the structure of multi-spar wings. He did not forget his conception, however, and pursued it vigorously; indeed, it became an obsession with him, and he lyrically dubbed the concept the "Silbervogel" (Silver Bird). He unveiled his concept in 1933, advocating the design of a winged aircraft propelled by a liquid-fuel rocket engine burning a mixture of petroleum and liquid oxygen, and capable of reaching Mach 10 flight speeds at altitudes in excess of 100 miles. Sänger elaborated upon this concept in his book Raketenflugtechnik, one of the major early texts of astronautical engineering, which he published privately that same year at great personal expense. Though he was deliberately vague about the geometric configuration of the vehicle, believing that configuration conceptualizations were beyond the scope of the book, he did select a general shape having (in his own words) a "spindle-shaped" fuselage, straight wings of low aspect ratio having sharp leading edges, a wedge

airfoil section, and moderate leading edge sweepback, with a rocket engine buried in the tail section of the vehicle. He considered this design quite conventional, but by the standards of the early 1930's, it was, in fact, a radical shape more typical of the configurations that marched across drafting tables in the late 1940's and 1950's. The next year, 1934, he again elaborated upon the design of such an aerospace aircraft. Assuming a lift-to-drag ratio of 5, Sänger predicted that the craft could attain a flight speed of approximately Mach 13 at the moment of fuel exhaustion, followed by a deceleration to steady supersonic cruise conditions of approximately Mach 3.3 at an altitude of around thirty miles, giving a total flight length of over 3,100 miles. Sänger next discussed less ambitious, but no less radical, concepts for single-seat rocket-propelled interceptors, and bombers<sup>3</sup>.

Sänger devoted the next decade to working on rocket propulsion, developing regeneratively cooled rocket engines. His major goal remained hypersonic boost-glide aircraft. In 1937, he began a collaborative research effort with his future wife, mathematician Irene Bredt. By late 1938, Sänger-Bredt had conceptualized an aircraft having a half-ogive fuselage shape, giving the vehicle the appearance of a laundry iron--which is what his research assistants nicknamed it. It retained the wedge-profile thin wings, but with a greatly reduced aspect ratio; it had endplate vertical fins on its horizontal stabilizer instead of the large single vertical fin of earlier studies. Sänger-Bredt estimated that this craft would have a supersonic L/D of 6.4, and subsonic testing revealed a L/D of 7.75. They proposed launching this craft from a Mach 1.5 rocket sled. The "Silver Bird" would have had a 100 ton thrust rocket engine for its main propulsion, operating at a chamber pressure of 100 atmospheres (exceeded in actual subsequent development only by the present-day Shuttle's own engines). Sänger-Bredt dubbed this craft the "Rocket

Spaceplane", and foresaw it performing orbital missions with a one-ton payload (based on 2 1/2 orbits) or a four-ton payload (based on a single orbit), or delivery of up to an eight-ton payload at an antipodal point halfway around the world from its launch site.

After the craft was boosted to lift-off velocity from the rocket-propelled sled, it would coast upwards and the pilot would then ignite its large rocket engine, boosting into space and attaining a peak velocity of approximately Mach 24. The vehicle would then reenter in a semiballistic manner, "skipping" off the denser atmosphere like a stone skipping off water, in a series of shallower and smaller skips, until, finally, it would enter a terminal supersonic glide. (Subsequent analysis has indicated that this planned flight path is undesirable from an aerothermodynamic loads standpoint, as each skip induces high thermal loads and prolongs the heat-soaking of the structure. A more acceptable approach is a steady decelerating descent followed by a hypersonic/supersonic glide, the approach currently taken by the Space Shuttle.)

Obviously, following Nazi Germany's decision to go to war in September 1939, the Rocket Spaceplane could not be pursued as extensively as in the pre-war years, for Nazi Germany now required immediate technical developments of benefit to its war machine. Sänger and Bredt shifted the project's emphasis from space transportation to a global rocket bomber (Rabo, for Raketenbomber) in a bid to receive continued official support. In December 1941, Sänger-Bredt submitted a draft report on the Rabo for approval by the Reichsluftministerium (RLM: the German Air Ministry); the report included a map of New York City labeled Zeil Eins: Target One. RLM officials were understandably cool--and possibly annoyed--to such a distant scheme at a time when Nazi Germany was fighting for its existence in a war of its own making. A few

months later, the Luftfahrtforschungsanstalt Hermann Göring (LFA: Hermann Göring Aviation Research Institute) rejected the report for publication, and Sänger, embittered and angry, joined the staff of the Deutsche Forschungsanstalt für Segelflug (the German Institute for Soaring Flight: DFS), at Ainring, in Bavaria, where he worked on ramjet propulsion schemes for high-speed airplanes. The DFS did publish an abbreviated and classified report on the Rabo project in 1944, and, after the war, copies of this report reached the highest councils of Allied technical intelligence teams, as will be seen<sup>4</sup>.

The Rabo (Figure 1) thus remained an intriguing paper study, but another Nazi boost-glide effort actually reached the hardware stage. At about the time that Sänger-Bredt were vainly trying to win official approval for the Rabo, members of Wernher von Braun's Peenemünde rocket development team were busily studying methods of increasing the range of ballistic missiles by adding sweptwings enabling them to glide to their targets. Under the direction of Ludwig Roth, team members developed a winged derivative of the V-2 (A-4) ballistic missile terror weapon. At an early stage in the development of the A-4, the Peenemünde team had embarked on a more ambitious venture, design of a long-range missile system capable of hurling a one-ton high-explosive warhead nearly 3,500 miles. Using a large booster designated the A-10 as the first-stage booster, planners envisioned a winged second stage, designated the A-9, that would fire into a ballistic trajectory and then transition to a terminal glide before impacting in the target area at about Mach 3.5 to 4.0. Because the Peenemünde facility could not support both the A-4 (V-2) effort and the ambitious A-9/A-10, work on the latter project continued at a slow pace, though small-scale powerless models of the A-9, designated A-7's, were dropped from a Heinkel He 111 bomber for stability and control studies. Eventually, even study

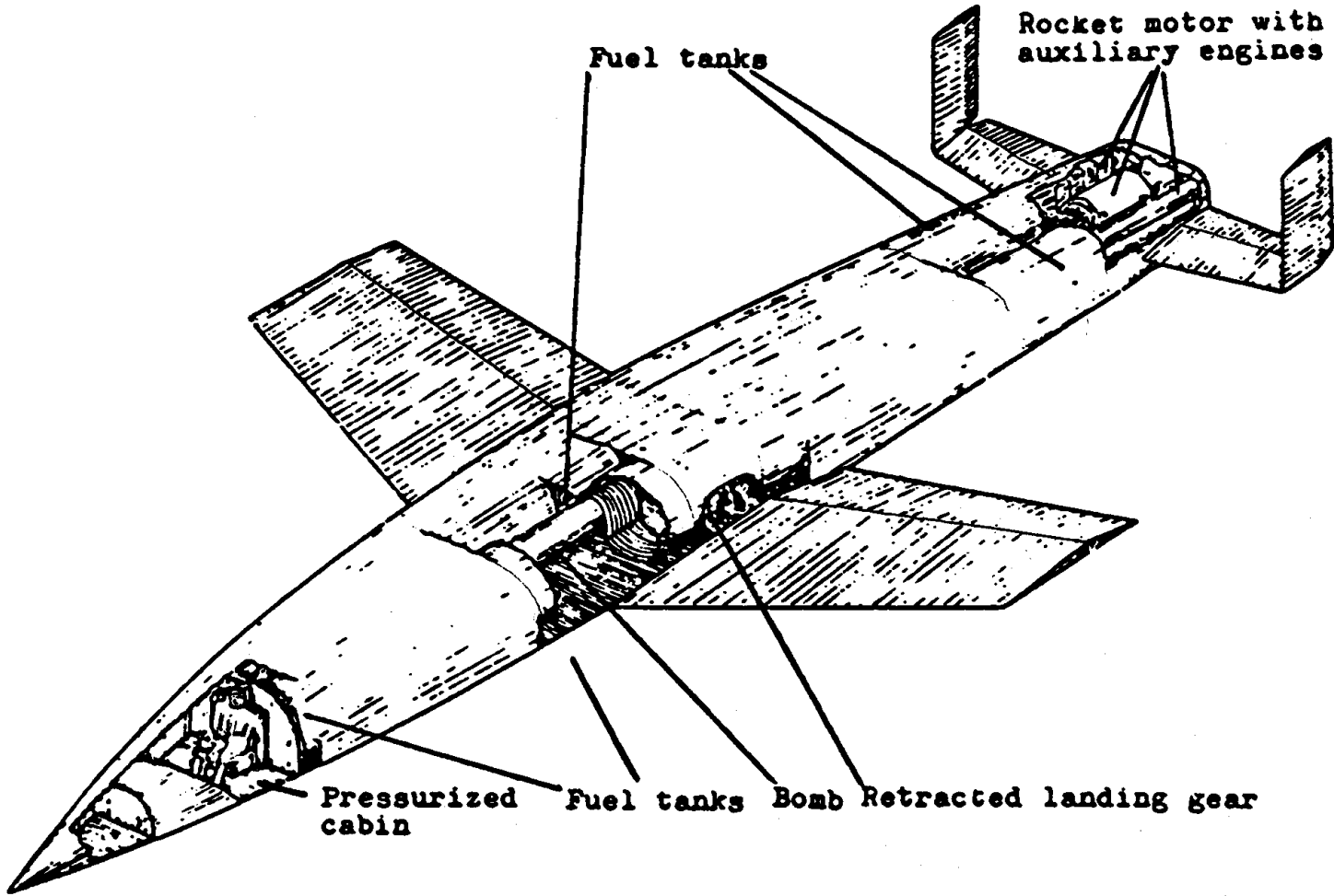


Figure 1

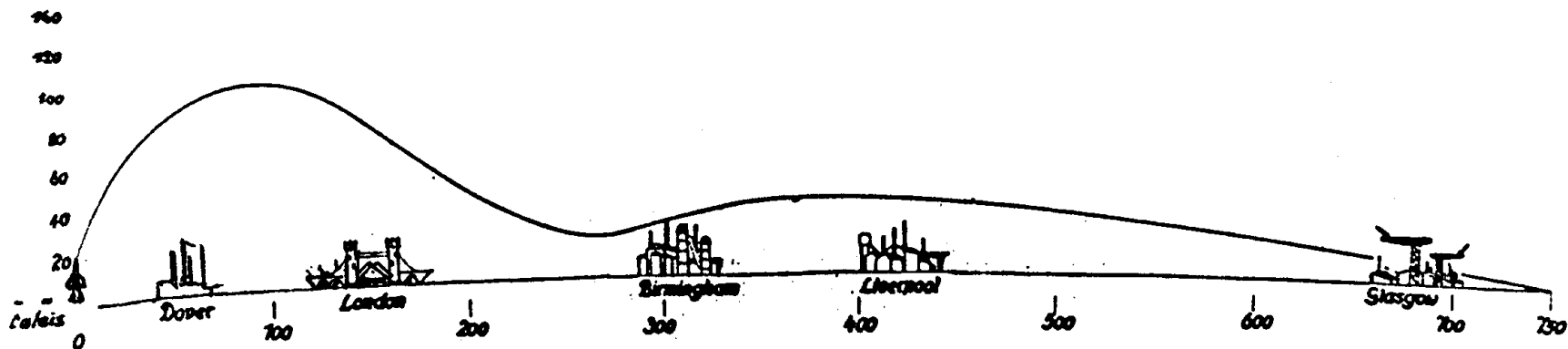
efforts were terminated in 1943. In 1944, however, in the face of intensive Allied air attacks on proposed and actual V-2 launch sites, work resumed on a winged A-4 derivative, for a winged A-4, having increased range, would obviate the necessity of locating V-2 firing batteries within easy strike range of Allied aircraft. Batteries instead could be located closer to the Nazi heartland. The winged A-4, designated the A-4b (for "bankert" - "bastard"), had a range of 465 miles compared to 150 miles for the purely ballistic V-2 then just entering service. (See Figure 2) Roth's team built two A-4b test articles and launched the first of these on January 8, 1945, but its control system failed just after launch. A second, launched on January 24, was more successful, transitioning to a Mach 4 supersonic glide from a ballistic reentry. During the glide, one wing failed due to excessive air loads, and the A-4b broke up. This was, incidentally, the first time that a winged vehicle had exceeded the speed of sound; the A-4b remained the fastest winged vehicle flown until the introduction of the X-15 research airplane. The rapid disintegration of the Eastern Front brought any further plans to test A-4b missiles to a halt<sup>5</sup>.

There was always a small coterie of space enthusiasts at Peenemünde who had to keep their more visionary projects out of sight of the more pragmatic ordnance experts of the Wehrmacht. One of these schemes envisioned a piloted version of the A-9 with a pressurized cockpit and a retractable tricycle landing gear, to be launched vertically and then landed powerless on a conventional runway, much as the present-day Shuttle. It could fly 400 miles at an average speed of Mach 2+. Beyond the A-9/A-10, the von Braun team had even conceptualized an advanced A-11, a three-stage vehicle whose final stage--a development of the A-9 boost-glider--would enter earth orbit. An "A-12", consisting of a large first-stage booster, an A-11 second stage, and a winged



"Flight path of a winged rocket"  
*Flugbahn einer Fernrakete mit Tragflügel*

"range = 750 km"  
*Reichweite: 750 km*



*Höhe und Entfernungen in km*

"Height and intermediate distances  
in km"

Calais    Dover    London    Birmingham    Liverpool    Glasgow

WMA	3201
SLA-Mark flight	

B 87/49 BSM

Figure 2

TRAJECTORY OF THE A-4b/A-9, FROM A

CAPTURED NAZI DOCUMENT

A-10, was forecast for delivering up to 30 tons into earth orbit, permitting the construction of a space station. Nazi scientists and technologists would have done well to remember "Those who live by projection die by reality"; these futuristic schemes collapsed amid the rubble of the Third Reich, before rising, Phoenix-like, in the postwar world.

The immediate postwar challenge facing aeronautics was that of manned supersonic flight. Despite ballistic and shell data, real doubts existed whether a manned aircraft could successfully traverse the transonic tangles and traps and attain sustained supersonic flight. Could, for example, the problems of high-drag rise, trim changes, and changes in control effectiveness be overcome? These critical questions remained unanswered at war's end. Indeed, a considerable body of evidence, accumulated from the wreckage of conventional aircraft lost in high-speed flight from "compressibility" effects, seemed to indicate that such problems could not be overcome, at least in the foreseeable future. The lack of reliable ground research methods (the slotted throat wind tunnel being a thing of the future), and the inadequacy of existing free-flight techniques using falling bodies, rocket-propelled test models, and wing-flow research methods, caused the United States to embark on an ambitious program of manned transonic and supersonic flight research using specially designed and instrumented research airplanes. This marked the birth of the so-called "X-series" of postwar research aircraft. As seen from a late 1950's perspective, there were three discernable phases to the X-series program. The first, dubbed "Round One" by engineers of the National Advisory Committee for Aeronautics (NACA--the predecessor to NASA), consisted of the Bell XS-1 (later X-1) series, the Bell X-2, the Douglas X-3, the Northrop X-4, the Bell X-5, the Douglas D-558-1 Skyrocket and D-558-2 Skyrocket, and the Convair XF-92A. Three of these, the

Bell X-1 series, the Bell X-2, and the Douglas D-558-2 Skyrocket, were supersonic rocket-propelled aerodynamic research aircraft air-launched for maximum performance from modified B-29 and B-50 carrier aircraft. The rest served to evaluate specific aerodynamic configurations, such as swept, tailless, and delta wing planforms. The second X-series phase was "Round Two", the North American X-15 project, inspired in part by the studies of Sänger and Bredt. The third phase, sequentially known as "Round Three", was the ambitious Boeing X-20A Dyna-Soar project, inspired jointly by the early work of Sänger and Bredt, as well as later indigenous American studies, and unfortunately aborted by Secretary of Defense Robert S. McNamara in December 1963<sup>6</sup>.

The "Round One" research aircraft accomplished the world's first manned Mach 1, 2, and 3 flights. The age of supersonic flight became a reality on October 14, 1947, when the first Bell XS-1, piloted by Capt Charles E. Yeager, USAF, exceeded Mach 1, attaining Mach 1.06 (700 mph) at approximately 43,000 feet. On November 20, 1953, NACA pilot A. Scott Crossfield made the first manned flight at Mach 2, twice the speed of sound, while flying the second D-558-2 Skyrocket. Nearly three years later, on September 27, 1956, Capt Milburn G. Apt reached Mach 3 while flying the first Bell X-2, unfortunately losing his life when the aircraft went out of control. Though these early X-series aircraft were, per se, benefitting the design of conventional aircraft that followed, they nevertheless contributed to a general base of knowledge that supported studies of more exotic hypersonic boost-glide vehicles. The X-2, for example, was the first aircraft that required a structure designed to withstand the problems of aerodynamic heating. During flight testing, it pointed to the need for reaction controls in order to maintain a desired attitude at high altitudes and low dynamic pressures, and reaction controls subsequently underwent evaluation on an advanced

X-1, the X-1B. These early X-series aircraft generally derived data that led to greater understanding of how wind tunnel information should be interpreted, aerodynamic heating at supersonic speeds, transonic and supersonic lift and drag, transonic and supersonic flight loads, transonic and supersonic stability and control (including understanding of such phenomena as exhaust jet impingement effects on stability, inertial coupling, directional instability), reaction controls, and requirements for flight crew physiological protection at high altitudes. Engineers also gained confidence operating with complex reusable man-rated rocket propulsion systems <sup>7</sup>.

The Sänger-Bredt report fell into Allied hands with the collapse of Germany in May 1945. It immediately excited great interest, and was soon translated in French, Russian, and English. It so impressed Josef Stalin that he sent a team to Western Europe to locate the Sängers (who had gone to France) and persuade them (by any means including kidnapping) to work in Russia (the plan failed). Walter Dornberger, who was aware of Sänger's work, subsequently joined the staff of the Bell Aircraft Corporation, where he championed development of a series of Rabo-like proposals, one of which (like its German counterpart) was known as Robo--for Rocket bomber\*. The most important contribution of Sänger's work was its impact upon the high-speed research community. It focused attention on the potential of winged hypersonic cruise aircraft, psychologically paving the way for the X-15, and inspired a number of studies of Sänger-Bredt type

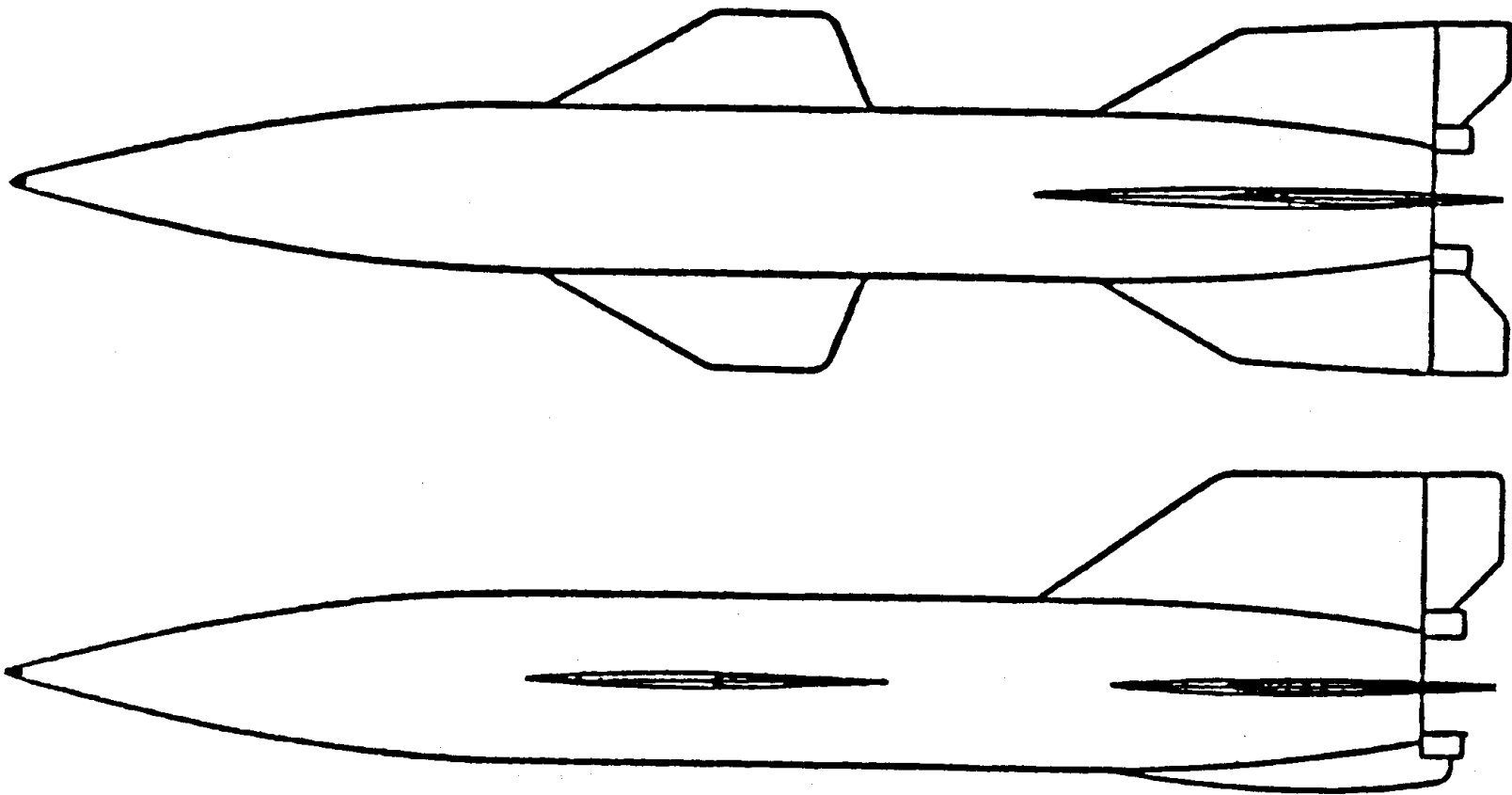
\*Sänger-Bredt later undertook further lifting reentry studies, culminating in Sänger's work on the German Ju RT-8-01 two-stage-to-orbit shuttle proposal of the early 1960's. He died in 1964.

hypersonic aircraft. In 1949, Hsue-shen Tsien, Theodore von Kármán's protege at the California Institute of Technology, conceptualized a hypersonic research aircraft that could point the way towards a Mach 12 "transcontinental rocket liner"\*. As a technology demonstrator, Tsien proposed developing a smaller hypersonic research testbed based closely on the shape of the Nazi Wasserfall (Waterfall) surface-to-air missile (Figure 3). This craft would have used liquid hydrogen fuel with liquid oxygen, or liquid hydrogen with liquid fluorine as the oxydizing agent. It would have a range of 3,000 miles, of which 1,800 would consist of a gliding descent from an altitude of 27 miles following transition to the glide phase from the elliptical boost trajectory. It would have a maximum speed of 9,140 mph, a landing speed of 150 mph, and a lift-to-drag (L/D) ratio of 4. Not surprisingly, the landing angle of attack would be 20 deg. Having drawn up this proposal, Tsien rather over-optimistically concluded that "the requirements of a transcontinental rocket liner are not at all beyond the grasp of present-day technology"<sup>8</sup>.

In October 1954, at the request of the Chief of Staff of the Air Force, the members of the prestigious Aircraft Panel of the Air Force Scientific Advisory Board submitted their thoughts concerning technology developments in aviation that could be expected to be of significance over the next ten years. Their report took the form of remarks directed on the status of research within particular technology fields, and, while they addressed a number of issues covering a broad spectrum of interests, they

\*In the mid-1950's, Tsien had his security clearance revoked; he subsequently emigrated to the People's Republic of China where he became the architect of Communist China's missile and space program, to the great discomfiture of the Soviet Union, which soon found its nuclear dominance of China a thing of the past.

Figure 3



Length: 78.9 ft.

Span: 18.9 ft.

Height: 16.5 ft.

Gross Weight: 96,500 lbs.

Gliding Weight: 24,100 lbs.

Fuel load: 72,400 lbs.

TSIEN HYPERSONIC RESEARCH VEHICLE (1949)



devoted their greatest attention to hypersonic flight. Their remarks are worth quoting at some length, not merely as an indication of the state of hypersonic studies in 1954, but also as an indication of how and in what form they thought hypersonic research should proceed<sup>9</sup>:

In the aerodynamics field, it seems to us pretty clear that over the next ten years the most important and vital subject for research and development is the field of hypersonic flows; and in particular, hypersonic flows with stagnation temperatures which may run up to the order of thousands of degrees. This is one of the fields in which an ingenious and clever application of the existing laws of mechanics is probably not adequate. It is one in which much of the necessary physical knowledge still remains unknown at present and must be developed before we arrive at a true understanding and competence. The reason for this is that the temperatures which are associated with these velocities are higher than temperatures which have been produced on the globe, except in connection with the nuclear developments of the last ten or fifteen years and that there are problems of dissociation, relaxation times, etc., about which the basic physics is still unknown. The experimental techniques which we believe will be important in this field are several. First, the use of supersonic wind tunnels; these are intrinsically and basically limited in stagnation temperature. They cannot simulate the stagnation temperatures that will occur in hypersonic flight in the atmosphere. On the other hand, they are useful and valuable tools. There are already fairly large facilities of this type now planned, authorized and under construction. It is our belief that additional, very large and expensive facilities of this type should not be planned at the present time, for what we have essentially in the program is sufficient at least until we know more about other possible means of attacking the problem, and about the limitations and the possibilities associated with hypersonic wind tunnels.

A second experimental technique involves



the use of shock tubes and other devices for producing extremely strong shocks. The characteristic of this type of technique is that the time available for measurements is measured in the order of milliseconds and this requires very special experimental procedures. It is our belief that in the near future there should be intensive pushing of this type of facility but that the most useful ones will in general be relatively small-scale and inexpensive. However, it should not be forgotten that quite possibly within the next two or three years techniques will be discovered, or invented, on a small scale, which will later make it desirable to go into very large scale and expensive apparatus.

Third, we think that the Air Force should keep an open mind and should be prepared to support unconventional or what one might call exotic approaches to the production of extremely high Mach numbers and extremely high stagnation temperatures. There are a number of rather fanciful schemes which have been suggested. The field is so difficult, and the type of conditions we are dealing with are so unusual, that some may prove to be useful. They certainly should be investigated and pursued.

The fourth experimental technique is that of rocket test vehicles and this will be discussed a little later in the second part dealing with physical devices. . . .

Structures and materials problems can be divided into two categories. The first includes those of structures and materials under flight conditions now obtainable but not yet operational with air-burning engines. Here we mean Mach numbers of the order of 2-1/2 to 3-1/2 and skin temperatures of 700-800 degrees Fahrenheit. This category can also be subdivided into two.

First are the essentially steady state problems where presently available metals can be used, although with some difficulty. It appears that composite materials could be developed which would have much superior properties to deal with this kind of environment. For example, various

types of laminated honeycomb and fibrous composites can certainly be developed and offer promise of giving considerable improvements in meeting these structural problems. Here it would seem that there are no big facility problems involved.

The second type of problem is that introduced by the transient heating which leads to very serious thermal-stress problems, and here again work on materials and on structural design will be required. Test facilities to simulate properly transient heating conditions constitute somewhat of a problem. Such facilities are not now available, and it may turn out that fairly elaborate and expensive ones may be required to investigate this field.

There is a specific recommendation which the Panel makes in connection with these two fields. There should be immediate emphasis on the development of non-isotropic or composite materials of the following types among others: Laminated Materials made of several alloys or combinations of metals, or from plastics; Honeycomb Composites of several types of alloys; Fibrous Materials with metallic or nonmetallic wires, and Pre-Stressed Ceramics. All of these we believe should be investigated and should be made subjects of continuing research.

The second of the structural problems is involved with the non-steady, extreme temperatures associated with the reentry problems for long-range ballistic rockets. This will involve not only structures but aerodynamics, materials, cooling, and a large number of other fields. As far as we can see, no very elaborate ground facilities will be used in this kind of investigation although a number of small-scale facilities will be required. The difficulty is that nobody sees how to design ground facilities that will match the conditions. Accordingly, the major experimental technique will almost certainly be rocket test vehicles.

Regarding physical devices or machines, we have essentially two forecasts and two

recommendations. The first deals with research vehicles. The Panel believes that the time has come to initiate two new research vehicle programs.

The first is a program in unmanned rockets for hypersonic speeds, and we feel that a fairly specific step-wise program should now be undertaken. We visualize three steps in this program: (1) The use of existing solid-propellant high performance rockets which have been developed within the last few years. As a specific example, the "LOKI" rocket is one which might be employed. These could be used in multiple end stages. Some studies which have been made indicate that by the use of a two-staged cluster of LOKIS one could get a 30-pound warhead or test head to a Mach number of about 10 to 12. This we believe is a step in which both the rockets and the instrumentation required are now available. (2) The second step, we believe, should be a more ambitious program using larger scale liquid-propellant rockets, at least for the boost phase. This would permit larger pay loads and, hence, more instrumentation and tests. (3) The third stage in this step-wise program of rocket test vehicles would be the Atlas test vehicle, which is already in essence proposed as one of the elements in the Atlas test program.

The second type of research vehicle which we feel is now ready for a program is one involving manned aircraft to reach something of the order of Mach Number 5 and altitudes of the order of 200,000 to 500,000 feet. This is very analogous to the research aircraft program which was initiated ten years ago as a joint venture of the Air Force, the Navy, and the NACA. It is our belief that a similar cooperative arrangement would be desirable and appropriate now and that we should get the sights, performance-wise, about as far ahead of the presently attained conditions as was done ten years ago, which means something of the order of Mach Number 5 and several hundred thousand feet of altitude. We believe that both of these research vehicle programs would pay off very substantially.

It is interesting to note the general reluctance of the

Panel to endorse the development of new hypersonic facilities, inasmuch as the panel members represented a broad spectrum of leading figures from the academic, industrial, and governmental aeronautical research field who--as this text reveals--clearly recognized the significance of hypersonic flight, and who might otherwise have been expected to strongly support such development\*. Such inconsistent attitudes, however, plagued many influential figures administering science and technology during the 1950's: Secretary of Defense Charles E. Wilson, an extreme example, once acidly remarked "Basic research is when you don't know what you're doing", and then, proving his actions spoke as loudly as his words, cut DoD's budget for basic research by ten percent (though existing economic and budgetary conditions effectively cut DoD's support of basic research by a whopping 25 percent). Ironically, of course, the "catch up" outcry after Sputnik discredited such thinking and ended such short-sighted penny-pinching. (In fact, over a decade later, in June 1968, the SAB found itself unanimously concluding that "we are not developing badly needed ground simulation facilities. . . . The timely provision of proper ground test facilities would substantially reduce the cost of a hypersonic development program while increasing the chances of a successful design of a hypersonic test vehicle". How times had changed. . . ). Eventually, the very kind of comprehensive, elaborate, and expensive hypersonic facilities decried by the SAB were, in fact, ultimately developed in the late 1950's into the 1960's (and a good thing, too), though, as will be discussed subsequently,

\*The members were Dr Clark B. Millikan, Chairman; Dr William Bollay; Dr Francis H. Clauser; Allen F. Donovan; Dr Pol E. Duwez; Robert R. Gilruth; Prof John R. Markham; Prof Francis R. Shanley; and Dr Homer J. Stewart.

facilities development tended to take on a piecemeal ad hoc character in the absence of comprehensive and insightful long-range planning.<sup>10</sup>

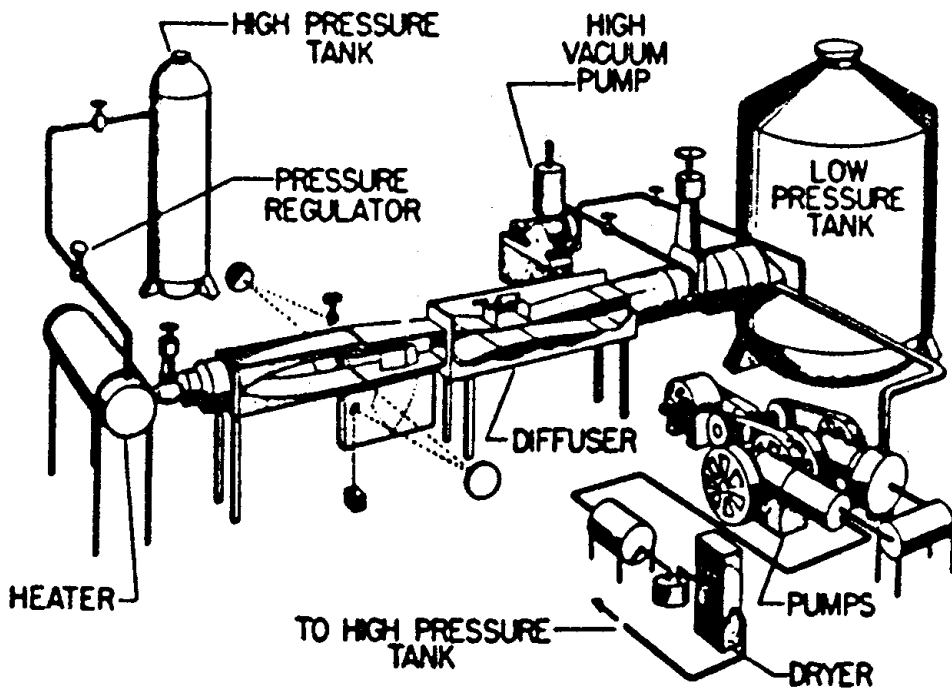
It is worth noting the state of hypersonic research facilities development from the 1940's since much of the hypersonic revolution would depend upon the reliability of such traditional sources of design knowledge as the wind tunnel. Before the Second World War, Jakob Ackeret had completed the first modern supersonic wind tunnel in the world, a Mach 2 design located at the Technische Hochschule of Zurich, Switzerland. Ackeret's tunnel inspired copies in Italy and Nazi Germany, and, together with the Volta Congress on High Speeds in Aviation held at Campidoglio, Italy, must be counted as one of the major factors influencing the birth of supersonic flight research coming on the heels of the advent of the first "modern" airplanes and the onset of the turbojet revolution. During the Second World War, Germany built no less than fourteen supersonic wind tunnels, including Mach 3.3 and 4.4 tunnels at a laboratory at Kochel, Bavaria, and, at war's end had a Mach 10 tunnel with a 1-meter-by-1-meter test section under construction at the same site\*. In any case, it was not until 1954 that a genuine Mach 10 tunnel appeared, and that facility, at Princeton University, utilized helium as a medium rather than air. A Mach 10 atmospheric type tunnel, of the kind underway at Kochel, did not emerge in the United States until the Arnold Engineering Development Center placed its 50 inch Tunnel C into service in 1961. Earlier, in 1945-49, John Becker and Alfred Eggers of the National Advisory Committee for Aeronautics had developed pioneering hypersonic tunnels. Becker's, at the Langley

\*At the end of the war, selected Kochel tunnels were transferred to the United States and installed at the Naval Ordnance Laboratory, White Oak, Maryland.

Memorial Aeronautical Laboratory, utilized a "blowdown" approach wherein air within a tank pressurized to fifty atmospheres was suddenly released into an eleven-inch test section and then recovered in a low pressure tank. (Figure 4) Eggers', at the Ames Aeronautical Laboratory, grew out of experiments in 1946 with a 1 in. x 1.4 in. nozzle. With data from these experiments in hand, Eggers and a development team completed a Mach 3 to Mach 6 tunnel in 1949 having a 10 in. x 14 in. test section; it could generate Reynolds numbers in the range of  $1 \times 10^6$ /ft. (Figure 5) Subsequent tunnels built along the lines of the Becker and Eggers models could generate Mach numbers up to 12 and Reynolds numbers in the range of  $2 \times 10^6$ /ft. An advanced Mach 7.2 blowdown tunnel exhausting to the atmosphere in service at the Massachusetts Institute of Technology's Gas Turbine Laboratory in 1951 is shown in Figure 6.<sup>11</sup>

Early tunnels such as these faced serious problems with liquification of air as it expanded upon passing through the tunnel nozzle. Heating it could limit this problem; for example, Becker's tunnel utilized an electrical resistance heater generating 700 degrees Fahrenheit temperatures. Going beyond Mach 12, however, demanded more novel approaches. Possible solutions involved using a test medium other than air or high temperature heaters. Antonio Ferri of the Polytechnic Institute of Brooklyn chose air heated by high temperature refractories. R. P. Shreeve of Princeton University's Gas Dynamics Laboratory changed both the medium and the method of heating. Working under contracts issued by the Office of Aerospace Research of the United States Air Force, Shreeve and S. M. Bogdonoff selected nitrogen as a test gas and then incorporated graphite heating. They were able to achieve test section Mach numbers greater than 20 with their nitrogen tunnel (Figure 7). By 1962, tunnels using advanced heating and

Figure 4



NACA LANGLEY 11 in. HYPERSONIC TUNNEL





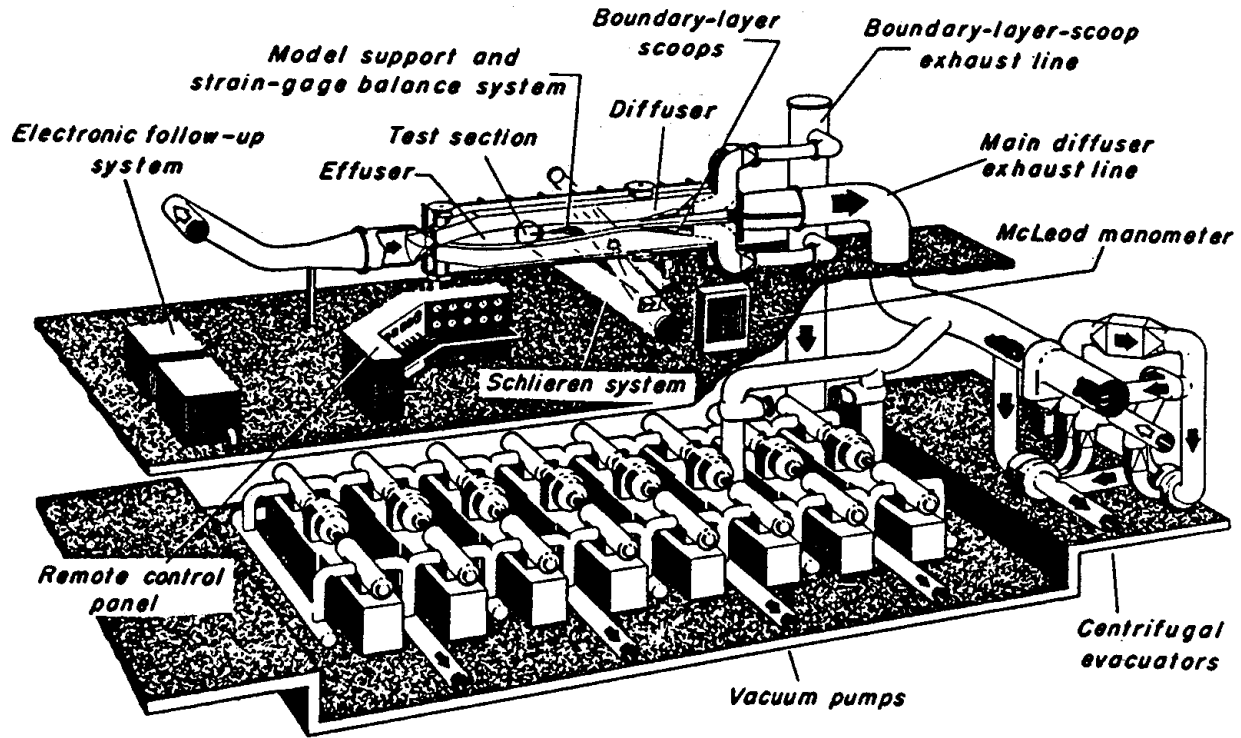


Figure 5



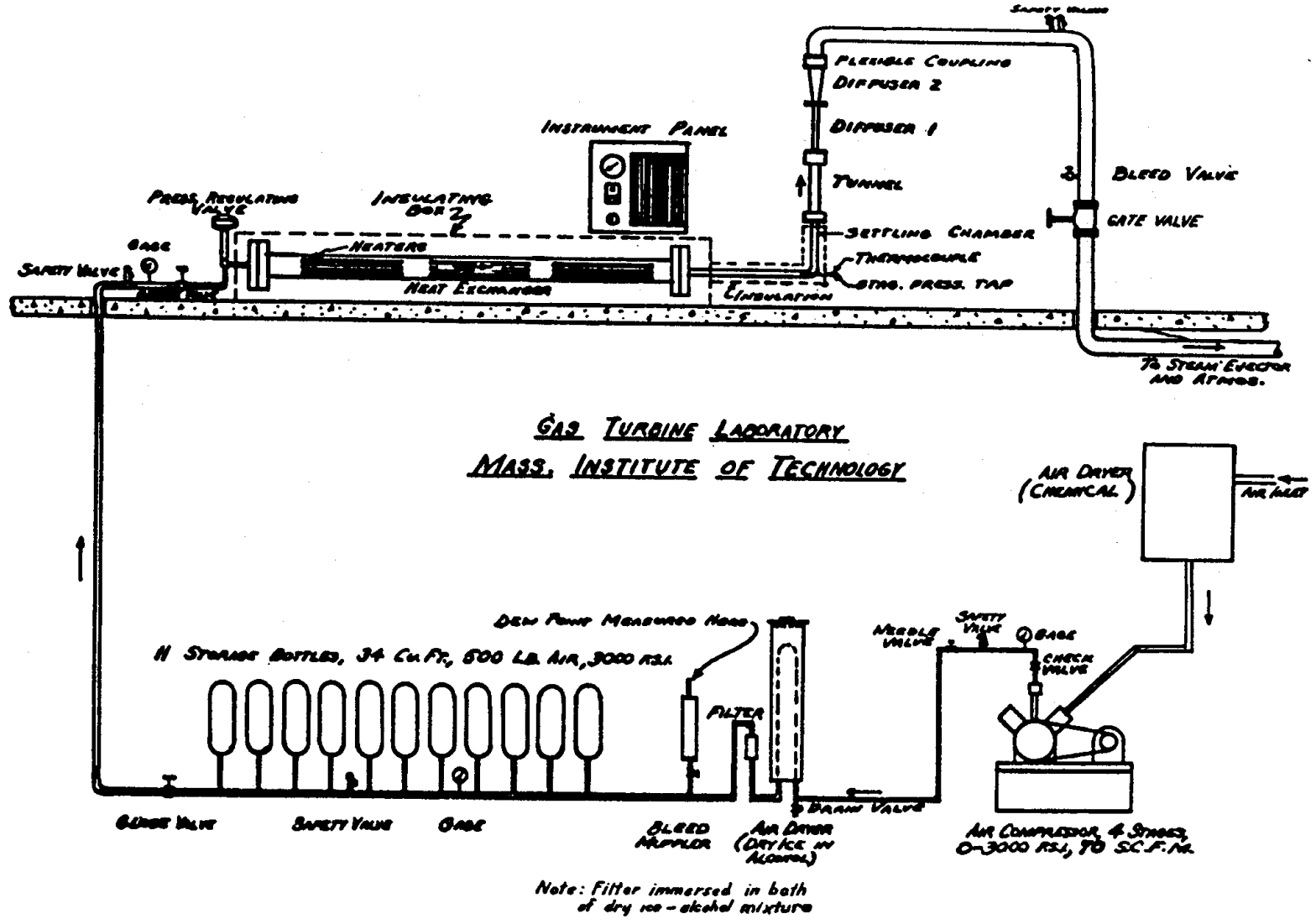
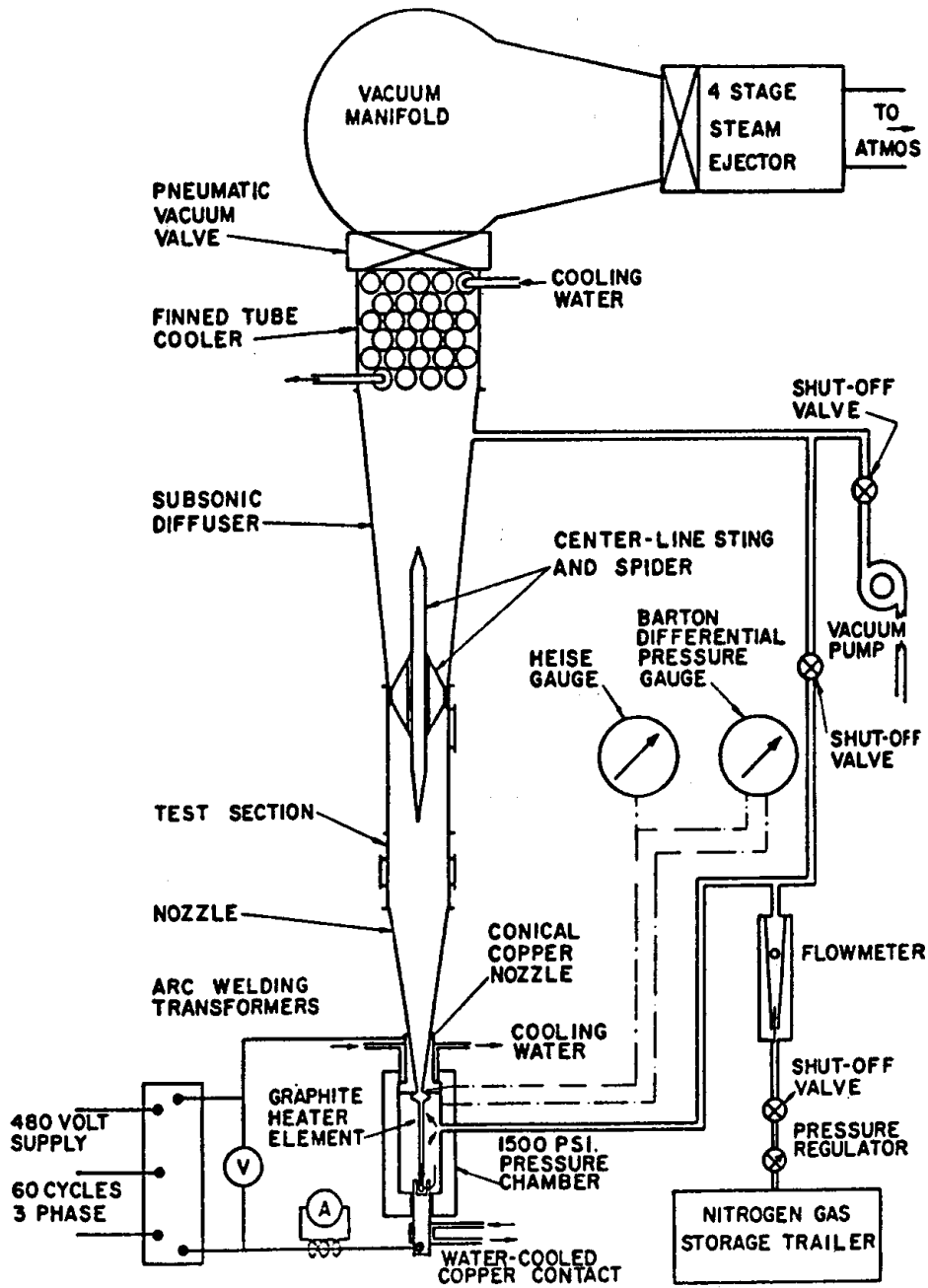


Figure 6



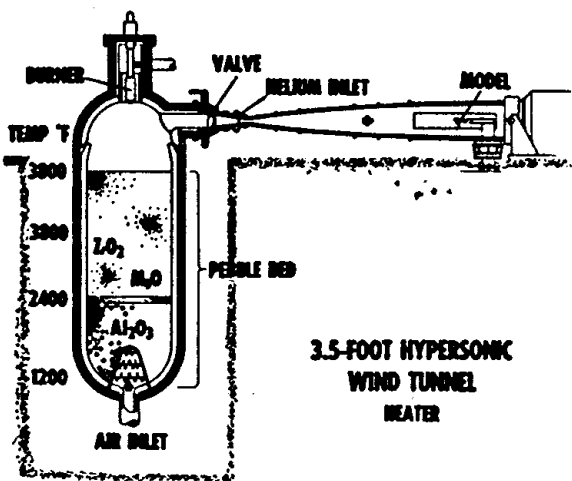
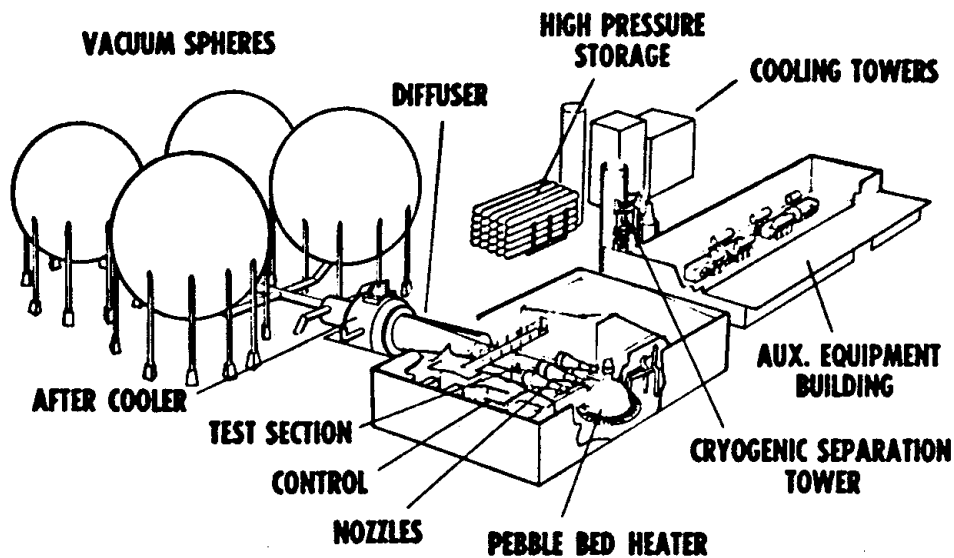
Figure 7



PRINCETON NITROGEN TUNNEL WITH GRAPHITE HEATING

gases such as helium and nitrogen could operate with accuracy to Mach numbers of 25--in short, up to return from orbit velocities; most tunnels, however, operated in the Mach 5 through 15 range. A particularly noteworthy tunnel was the Ames 3.5 ft. facility championed by Alfred Eggers and authorized in 1957, shown in a schematic view in Figure 8. This facility used four interchangeable nozzles permitting operation at Mach 5, 7, 10, and 14. It simulated flight Reynolds numbers up to Mach 10 and flight temperatures up to Mach 7. A pebble bed heater consisting of an insulated pressure vessel filled with 125 tons of aluminum and zirconium oxide pebbles heated inlet air to 4,000 degrees Fahrenheit temperatures. (However, at Mach 14 velocities, dust from the glowing pebbles effectively sandblasted the nozzle, causing such deterioration that, for practical purposes, NASA limited the tunnel to Mach 10). Cooling both the chamber of the heater and the tunnel walls posed difficult challenges, met in the former case by using both a refractory brick lining and cooling water coils, and in the latter by incorporating slots in the tunnel throat for injection of a cooling boundary layer of helium gas to hug the walls. This tunnel, and a subsequent Mach 10 continuous flow tunnel developed by Eugene Love and placed in service at NASA's Langley Research Center in 1962 (see Figure 9) subsequently played major roles in the aerodynamic and heat transfer studies NASA undertook in support of the Space Shuttle. One particularly useful refinement involved the development of hypersonic tunnels capable of operating at low stagnation pressures utilizing arc-jet heating. Arc-jet (also called plasma jet) tunnels utilized continuous electric arcing to heat gas in the tunnel's stilling chamber to temperatures on the order of 10,000 to 20,000 degrees Fahrenheit. This heated gas is then injected into the tunnel nozzle. Figure 10 shows a schematic view of an early arc-jet tunnel constructed at Ames Research Center.

Figure 8

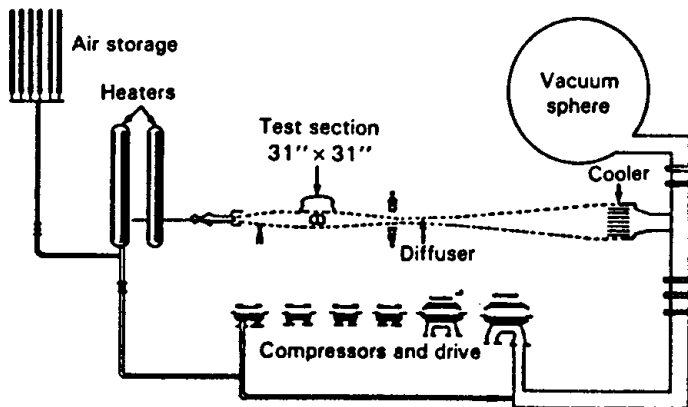


*Schematic drawings of the 3.5-foot hypersonic wind tunnel (above) and (at left) the 3.5-foot tunnel pebble-bed heater.*

3.5-FOOT HYPERSONIC WIND TUNNEL HEATER

NACA AMES 3.5 ft. HYPERSONIC WIND TUNNEL

Figure 9

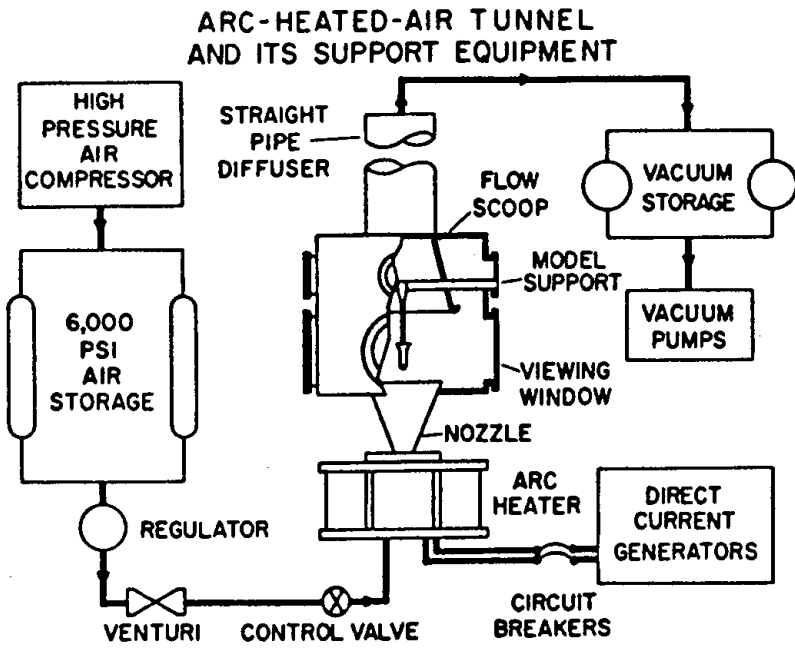


NASA LANGLEY MACH 10 CONTINUOUS FLOW TUNNEL





Figure 10



NACA AMES EXPERIMENTAL ARC-JET TUNNEL FACILITY

Arc-jet tunnels experienced serious problems with electrode erosion and cooling of the tunnel throat; also, attempts to apply arc-jet heating to higher stagnation pressure tunnels proved disappointing, and, as a result, arc-jet facilities became utilized primarily for heat transfer and materials studies, as opposed to aerodynamic research<sup>12</sup>.

Hypersonic tunnel nozzle design posed particularly thorny design challenges for tunnel developers. Boundary layer formation in two-dimensional tunnel nozzles severely limited the potential usefulness of such configurations for tunnel design and spawned greater interest in so-called axisymmetric designs which could furnish uniform boundary layer conditions. Such nozzles appeared on supersonic tunnels in the United States and Sweden, and at hypersonic facilities in the United States. A team led by S. M. Bogdonoff applied such axisymmetric nozzle design to a hypersonic helium tunnel at Princeton in 1950. Subsequently, a team directed by Antonio Ferri at the Polytechnic Institute of Brooklyn incorporated a similar design in 1955, and in 1956, J. D. Lee and G. L. von Eschen applied an axisymmetric nozzle to a hypersonic wind tunnel at Ohio State University. The axisymmetric nozzle, refined over time, is now a standard feature of "conventional" hypersonic tunnels<sup>13</sup>.

Other ground-based test facilities contributed markedly to hypersonic research, notably a specialized group of test apparatus known as impulse tunnels, and consisting of shock tubes, shock tunnels, and so-called "hotshot" tunnels. The shock tube dates to the nineteenth century French chemist Paul Vieille who advocated it as a means of studying mine explosions. His work was taken up by other European scientists (including occasional simultaneous "discovery" followed by invention and re-invention) but it was not until the 1950's that physicists began using the shock tube for hypersonic research. A shock tube consists of a long constant

diameter tube containing high-pressure gas (termed the "driver gas") and low-pressure gas (termed the "working gas") separated by a frangible diaphragm. Rupturing the diaphragm releases a high-energy shockwave to accelerate and compress the working gas. The generated shockwave passes over a model placed in the tube, and the model is briefly exposed to a region of continuous flow before the "contact surface" of the driver gas encounters the model. Expanding the working gas through a hypersonic nozzle (thus creating a shock tunnel) can generate higher (but briefer) Mach numbers than a simple shock tube. By reflecting the shockwave via a convergent-divergent nozzle having a smaller throat size than the diameter of the tunnel, the test gas is briefly decelerated and further compressed; it passes through another diaphragm into an expanding nozzle where, for several milliseconds, it sweeps through the test section and around a test model at velocities of up to 15,000 ft/sec and stagnation temperatures on the order of 20,000 degrees Fahrenheit. This latter type of shock tunnel is commonly referred to as a "reflected shock" tunnel. Figure 11 shows a schematic view of the 48-inch Hypersonic Shock Tunnel placed in service at the Cornell Aeronautical Laboratory; it could operate from Mach 5 to 18 at temperatures of 2,000 to 6,000 degrees R, and with a duration of 6 to 17 milliseconds. Like other early tunnels mentioned in this account, the 48-inch CAL hypersonic tunnel played a leading role in several of the major hypersonic technology development programs discussed subsequently<sup>14</sup>. "Hotshot" tunnels first appeared at the Arnold Engineering Development Center, and were intended to provide a very high enthalpy (i.e., heat content) flow by heating a burst of test gas using electric arc discharge. The gas would burst through a diaphragm with a pressure as high as 2,000 atmospheres and a temperature on the order of 10,000 degrees Fahrenheit, then expand through a nozzle and around a test model



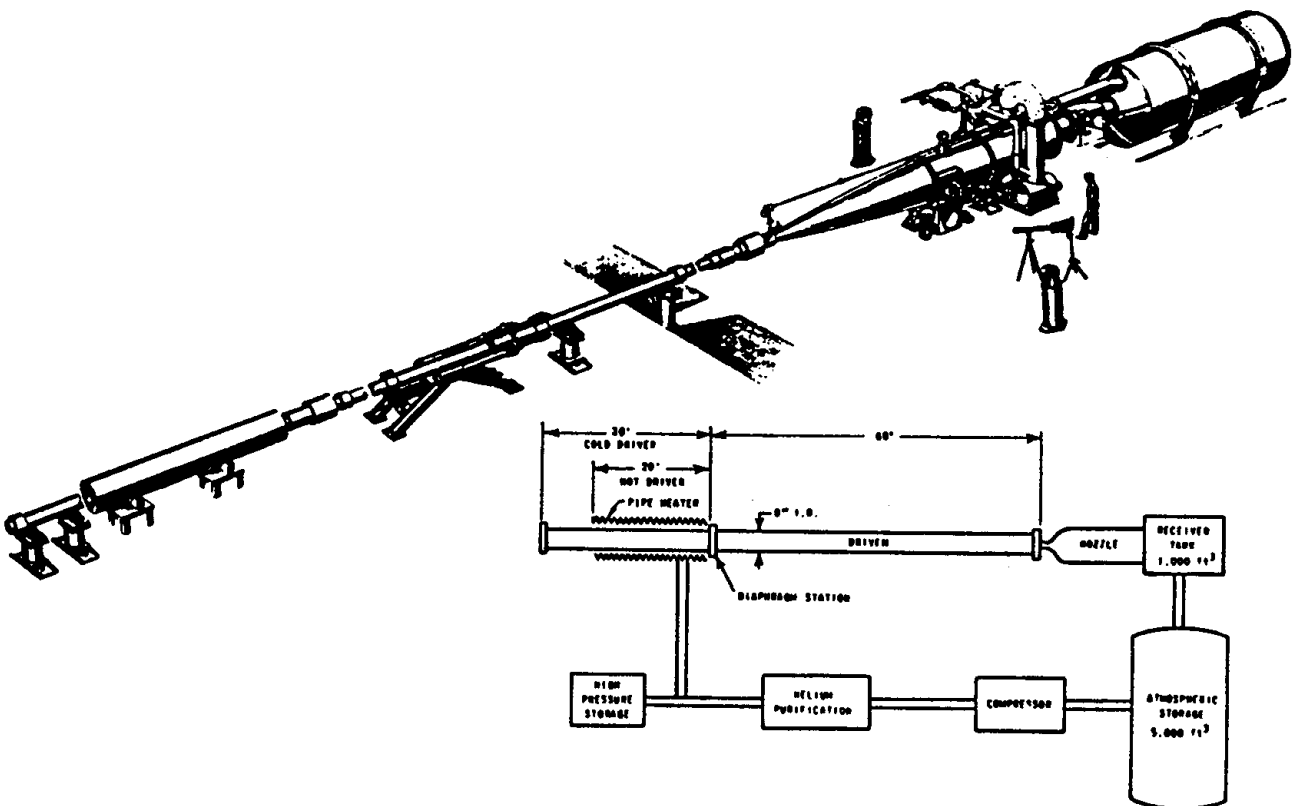
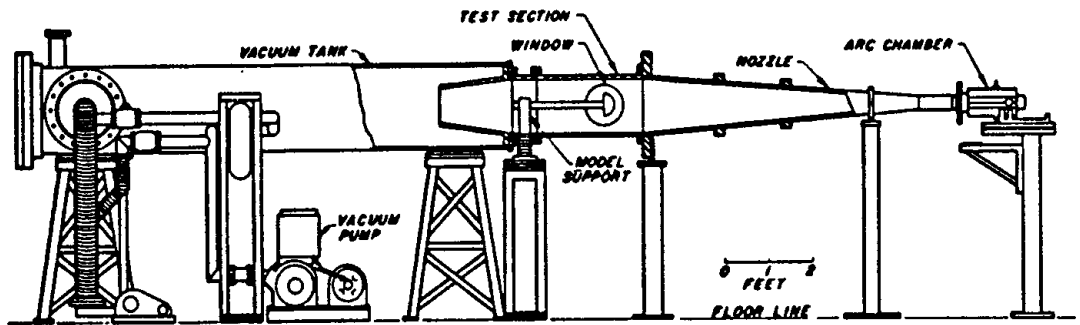


Figure 11

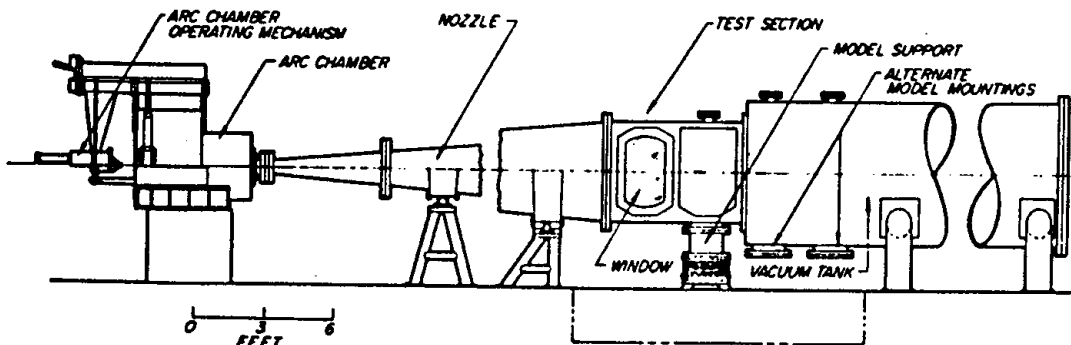
with a velocity of between Mach 8 and Mach 25 for a duration up to approximately 100 milliseconds, longer than comparable conditions generated in a conventional shock tunnel. In reality, however, hotshot facilities proved disappointing due to high heat losses and contamination of the test flow from the electrodes themselves and the arc chamber. Figure 12 shows the Hotshot 1 16-inch tunnel and Hotshot 2 50-inch tunnel of the von Kármán Gas Dynamics Facility, Arnold Engineering Development Center. In service in time to support work on a number of Air Force reentry projects including the X-20 Dyna-Soar, these two typified the development of the hotshot approach. Hotshot 2 could reach Mach numbers of approximately Mach 22 at stagnation temperatures of 3,000 to 4,000 degrees K, and with stagnation pressures of 10,000 to 20,000 psi. Deficiencies aside, hotshot tunnels did prove useful in simulating both Mach number and Reynolds number combinations. Additional test methods developed to support hypersonic research have included the Ludwig Tube blowdown tunnel, and various free piston compressor tunnels, but since these were largely post-1960 developments, they are not examined here in detail.<sup>15</sup>

Hypersonic wind tunnels, shock tubes, and shock tunnels constituted a very important part of the hypervelocity research story; another important element was the hypervelocity range. Hypervelocity ranges offered significant advantages over the more conventional tunnel approach, primarily in more closely duplicating "real world" flight Reynolds numbers and real gas effects. Interestingly, the development of the hypervelocity range was stimulated by the study of meteorites and their ablative characteristics as they enter the atmosphere and plunge to earth. In 1946, Dr W. D. Crozier and Dr William Hume of the New Mexico School of Mines undertook development of a so-called "light gas gun" in response to a study contract from the Navy Bureau of Ordnance. This early effort sparked much subsequent interest, and

Figure 12



AEDC vKGDF HOTSHOT 1 16 in. TUNNEL

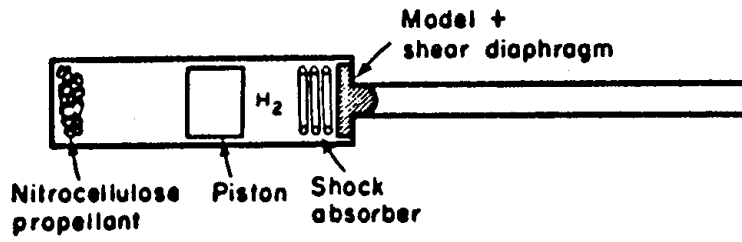


AEDC vKGDF HOTSHOT 2 50 in. TUNNEL

made use of a piston driven by high explosive detonation to compress hydrogen gas, which would then flow around a model with a velocity of up to 12,000 ft/sec. The results of the New Mexico School of Mines gun (shown schematically in Figure 13) experiment greatly excited hypersonic researchers, and resulted in similar facilities being constructed in the United States and abroad, including facilities at the Naval Ordnance Laboratory and the Aberdeen Proving Grounds. Dr Alex Charters applied the concept to a light gas gun at the Ames Aeronautical Laboratory of the NACA<sup>16</sup>. Charters' work followed on the heels of an abandoned proposal by NACA engineers in 1947 to develop a free-flight aeroballistic facility at Ames, and resulted in the first light gas gun built for model launching in the United States. Ames engineers undertook to develop a small launching gun firing a model shrouded in a shedding sabot, placing this launcher in the diffuser section of a small unheated supersonic wind tunnel. Thus, the velocity of the model would be added to the velocity of the tunnel (about Mach 3), generating free-flight data at about Mach 10. With a projectile velocity of about 8,000 ft/sec, values up to Mach 15 could be generated. The tunnel had a test section of eighteen feet with flow observation windows so that photoelectric instrumentation could take shadowgraph imaging of the model as it flew towards a model catcher located beyond the tunnel's supersonic nozzle (see Figure 14). With this device, researchers could measure drag, lift, pitching moments, center of pressure travel, skin friction, boundary-layer transition from laminar to turbulent flow, roll damping, and aileron effectiveness. Of necessity models had to be quite small; the technique, however, gained general acceptance, and Ames subsequently built a much more elaborate hypervelocity free-flight facility in the mid-1960's.<sup>17</sup> At the suggestion of Alfred Eggers, engineers under the direction of Stanford Neice went beyond this with the development of an

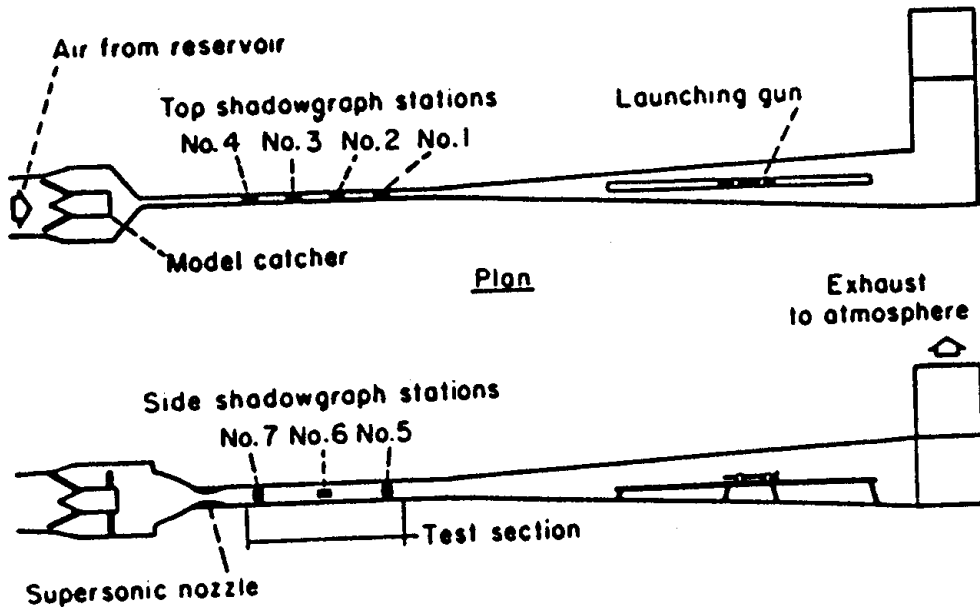


Figure 13



NEW MEXICO SCHOOL OF MINES LIGHT GAS GUN

Figure 14



NACA AMES EXPERIMENTAL FREE-FLIGHT WIND TUNNEL

atmospheric entry simulator at Ames. Like the free-flight gun tunnel, this facility made use of a gun firing a sabot-shrouded model into the flow of a supersonic tunnel. However, in this simulator, the tunnel had heating and while the launcher gun imparted the desired atmospheric entry velocity to the model, the tunnel nozzle generated a scaled approximation of the atmosphere. Thus, using a model shaped like an actual proposed vehicle and constructed from the materials intended for the actual vehicle as well, researchers could duplicate the aerodynamic heating and thermal stresses experienced by a returning body from space. Ames researchers first conceptualized this facility in terms of ballistic missile studies, but, of course, it soon proved its worth for more generalized applications in the reentry technology investigation field. Figures 15 and 16 give schematic views of the simulator, as well as a comparison of theoretical and experimental velocity vs. altitude plots for a missile simulated by a small copper-faced model; obviously, the test results were in good agreement with theory<sup>18</sup>.

It must be noted that all of the type of facilities that have been discussed in this text were in service or had inspired more advanced derivations that were in service by 1963, the year ASSET flew, much of PRIME's tunnel work had been completed, and also, sadly, the year Dyna-Soar (the X-20) was cancelled. Simulation capabilities existing at that time are shown in Figure 17. During the height of the space program in the 1960's, even more impressive facilities came on line or were begun, such as Langley's 8-foot High Temperature Structures Tunnel, a nonreturn tunnel making use of a methane heater. This tunnel, ordered in 1960, was not ready until 1968, and thus played no role in the Apollo development effort. It did, however, have profound value for the full-scale testing of components (such as the thermal protection tiles) for the Space Shuttle. At the Air Force's

Figure 15

NACA AMES ATMOSPHERIC ENTRY SIMULATOR

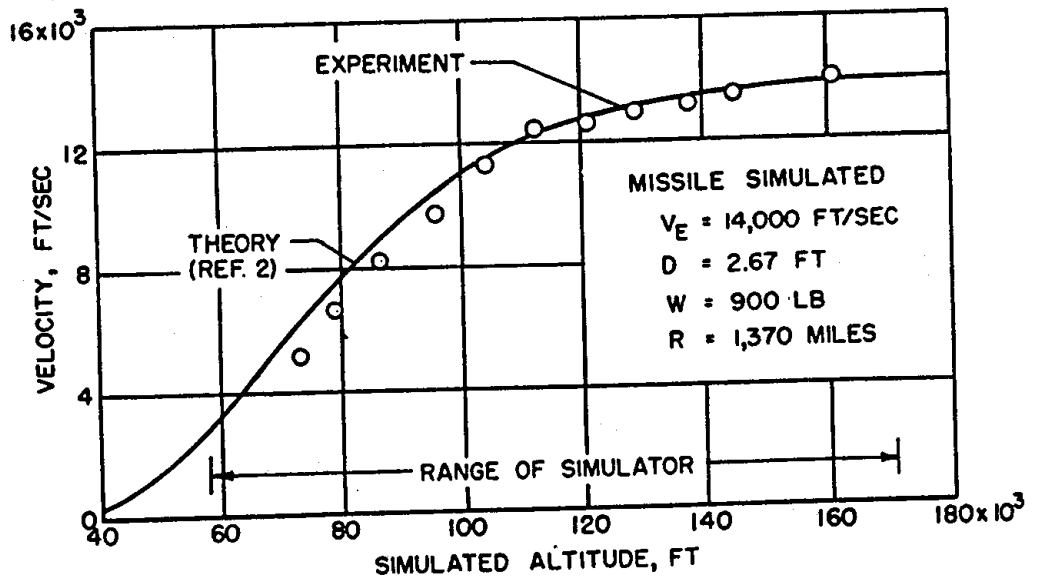
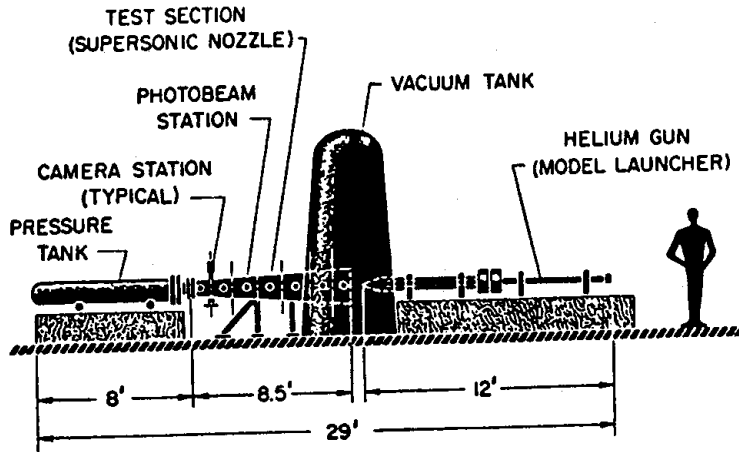
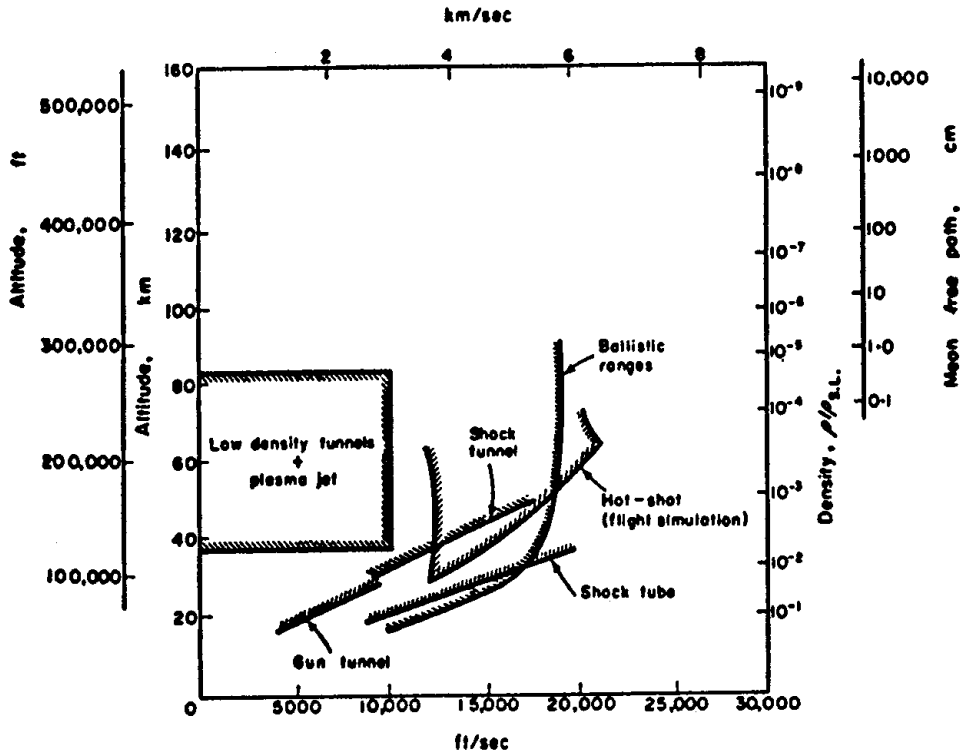


Figure 16

THEORETICAL VS. EXPERIMENTAL RESULTS FOR A  
 MISSILE SIMULATION USING THE  
 NACA AMES ATMOSPHERIC ENTRY SIMULATOR

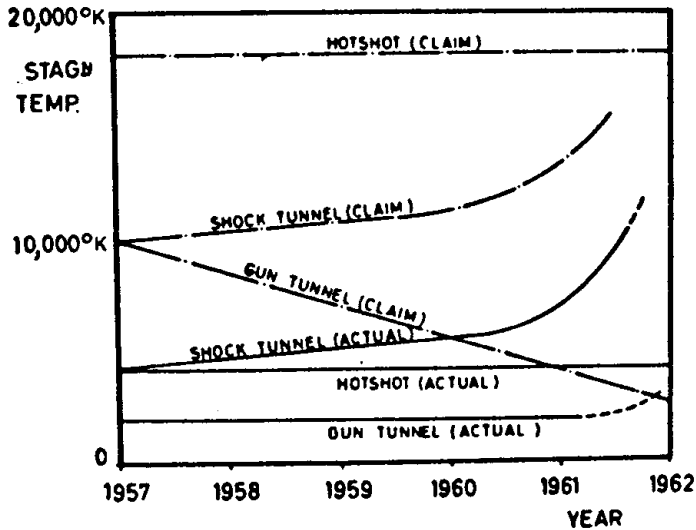


Figure 17



SIMULATION FACILITY CAPABILITIES IN THE EARLY 1960's\*

Figure 18



ACTUAL VS. CLAIMED CAPABILITIES  
OF SELECTED SIMULATION FACILITIES\*\*

\* From Cox, p. 173.

\*\* From Lukasiewicz, p. 247.

laboratory complex at Wright-Patterson AFB, Ohio, three noteworthy hypersonic ground test facilities were constructed for a total cost of just over \$22 million in the 1962-1969 time period. These were a 30-inch Mach 16-22 intermittent blowdown hypersonic tunnel, a 50-megawatt continuous-flow arc-heated hypersonic tunnel used for reentry and thermal protection systems studies, and a 2-foot arc-heated Mach 6-12 tunnel for aerodynamic force, pressure, and heat transfer testing.

Overall, as mentioned earlier, the various tunnels and impulse facilities and ground-based free-flight ranges proved of vital importance to the development of hypersonic vehicles during the 1960's. However, a cautionary note must be added as well: while valuable, the facilities rarely totally lived up to the expectations of their creators, who expected that they would offer unparalleled advances in hypersonic test techniques. Hypersonic research pioneer Julius Lukasiewicz has identified four specific technical criticisms of hypersonic facilities development, including "ad hoc" development, deficiencies in technical judgment, information transfer lag, and inadequate criteria for decisions on test facility development of test techniques<sup>19</sup>. Lack of systematic planning, he believes, led to "ad hoc" attitudes and behavior resulting in erratic exploitation of key ideas such as heating techniques and certain test methods, and generation of parochial attitudes so that specific institutions became over-enamoured and over-identified with specific test and research methodologies and facilities, such as shock tunnels at Cornell Aeronautical Laboratory, hotshot tunnels at the AEDC, and Ames' fascination with gas gun techniques.<sup>20</sup> Lack or lapses in technical knowledge and judgment resulted in overoptimistic prediction on one hand and failure to appreciate the magnitude of problems on the other. For example, researchers initially believed that the traditional two-dimensional nozzle of the

conventional supersonic tunnel would work satisfactorily for the hypersonic tunnel as well, only learning with actual experience of the problems with thickened boundary layer that afflicted such designs. "While conservatism often marked the design of hypersonic test facilities", Lukasiewicz pointedly remarks, "optimism was quite common as regards their performance".<sup>21</sup> Figure 18 offers a dramatic plot of claimed vs actual temperature performance for selected test facility types, during the time period in which many of the vehicles discussed in the case studies in this document were undergoing their formative development, clear supporting evidence of his judgment. Lukasiewicz suggests that mere technological lack of awareness served to hinder development of specific test methodologies and techniques; the shock tube's early history and transfer from Europe to America is one such example. Finally, Lukasiewicz notes that hypersonic facility development in the Western nations all-too-often was dependent upon strong governmental pressures generated in the face of external forces--first the reaction to the technological harvest of Nazi Germany's wartime research which inspired the first wave of hypersonic facility development after 1945, and secondly, the response to Sputnik in 1957 and the growing Soviet-American "space race". Arguments as to the necessity for such facilities purely for generating theoretical and experimental information fell largely on deaf ears, in part, Lukasiewicz believes, because of "the tendency of the organizations responsible for aeronautical and aerospace projects to insist on absolute and complete proof--in technical, military, cost-effectiveness, or economic terms--of the necessity to provide a new test capability."<sup>22</sup> Such tendencies, he believes, are unreasonable since:<sup>23</sup>

it is preposterous to suggest that the benefits of experimental equipment, such as wind tunnels required to uncover and investigate new

phenomena, could be evaluated precisely a priori. Were this the case, such equipment would be unnecessary. At best, a "positive proof" can only come too late, in the shape of a serious performance deficiency or discovery of technological lag relative to other competing groups.

Unfortunately, Lukasiewicz's perceptive comment could serve as an epitaph for certain selected development projects including actual abandoned research vehicles, notably the X-20 Dyna-Soar shortsightedly cancelled for the exact "reasons" offered above. Overall, the deficiencies he notes in the early history of hypersonic facilities, and his emphasis on goal-oriented long-range facilities planning should be kept in mind by members of today's hypersonic community as they address the problems and needs inherent in future systems such as the National Aero-Space Plane (NASP).

Hypersonic researchers of the 1950's and 1960's did not neglect other and more challenging means of research, particularly that of large-scale test methods involving use of air-and-ground-launched rockets, cannon-launched ballistic shapes, and, ultimately, development of complex manned and unmanned hypersonic research vehicles--the latter of which are the subject of various case studies in the following volumes. As can be seen, then, the hypersonic breakthrough of the postwar years was, like earlier aerospace transformations, the product of combined and complementary forms of research that intertwined, generating beneficial synergistic impulses that affected the development of the entire hypersonic data base. What is intriguing to note is how rapidly developments in the hypersonic field moved from theory to actual flight testing and hardware creation. In part, this stemmed from the supportive climate of national aerospace systems to meet anticipated national security needs in the 1960's and beyond. But the emerging "space race" was only a single factor in



the expansion of hypersonic research. Much of it, as has been demonstrated earlier in these pages, stemmed from long-standing interest and research that had first appeared in the form of theoretical studies in the early days of aeronautical evolution, and which only now, in the late 1950's and 1960's, had reached the point of practicality. Fulfilling the promise of hypersonic flight, however, required detailed attention to multiple forms of research, if the requisite technology base for future manned and unmanned systems were to be properly established.

One method of research that immediately came to mind involved firing small rocket or ramjet-propelled models from aircraft at reasonably high altitudes. In one such test on March 17, 1953, a North American F-82 Twin Mustang launched a JATO-boosted cone-cylinder test vehicle while cruising at 35,000 feet over the NACA Pilotless Aircraft Research Station at Wallops Island, Virginia. The small test vehicle (developed by NACA's Lewis Flight Propulsion Laboratory, now the NASA Lewis Research Center) returned data on acceleration; maximum velocity; ambient pressure; net thrust; heat-transfer; and total, pressure, friction, and base drag values while reaching a maximum speed of Mach 5.18 and a Reynolds number of  $107 \times 10^6$ . A cutaway of this research model is shown in Figure 19.<sup>24</sup> Though not precisely a hypersonic research tool, the Air Force-sponsored Lockheed X-7 and X-7A family of reusable pilotless research vehicles furnished much useful high-supersonic (up to Mach 4.31, 2,881 mph) information, primarily on aerodynamics, structures, and ramjet engine performance during a flight research program lasting from 1951 to 1960. Launched from modified Boeing B-29 and B-50 Superfortresses, and boosted initially by an ungainly-looking 105,000-pound thrust solid-fuel rocket, the X-7 relied upon either Wright or Marquardt ramjets ranging from 20 in. to 36 in. diameter for sustained propulsion. Figure 20 shows the basic X-7's



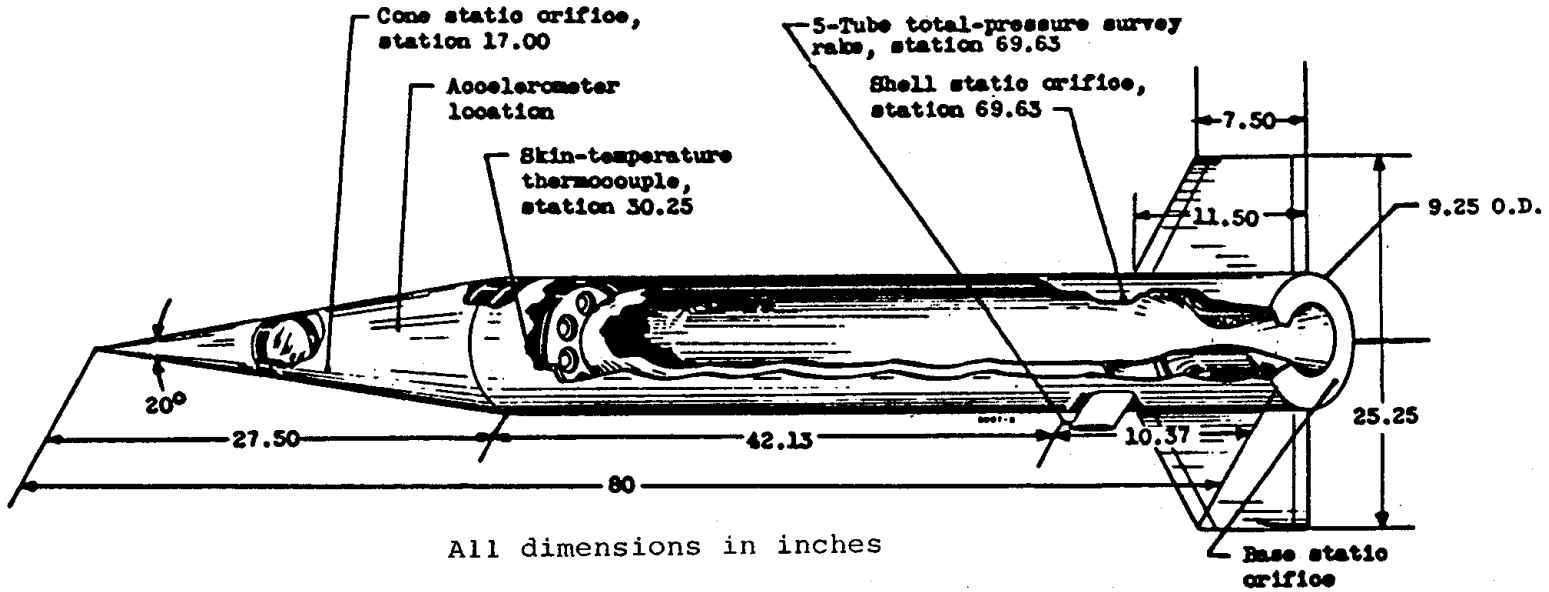
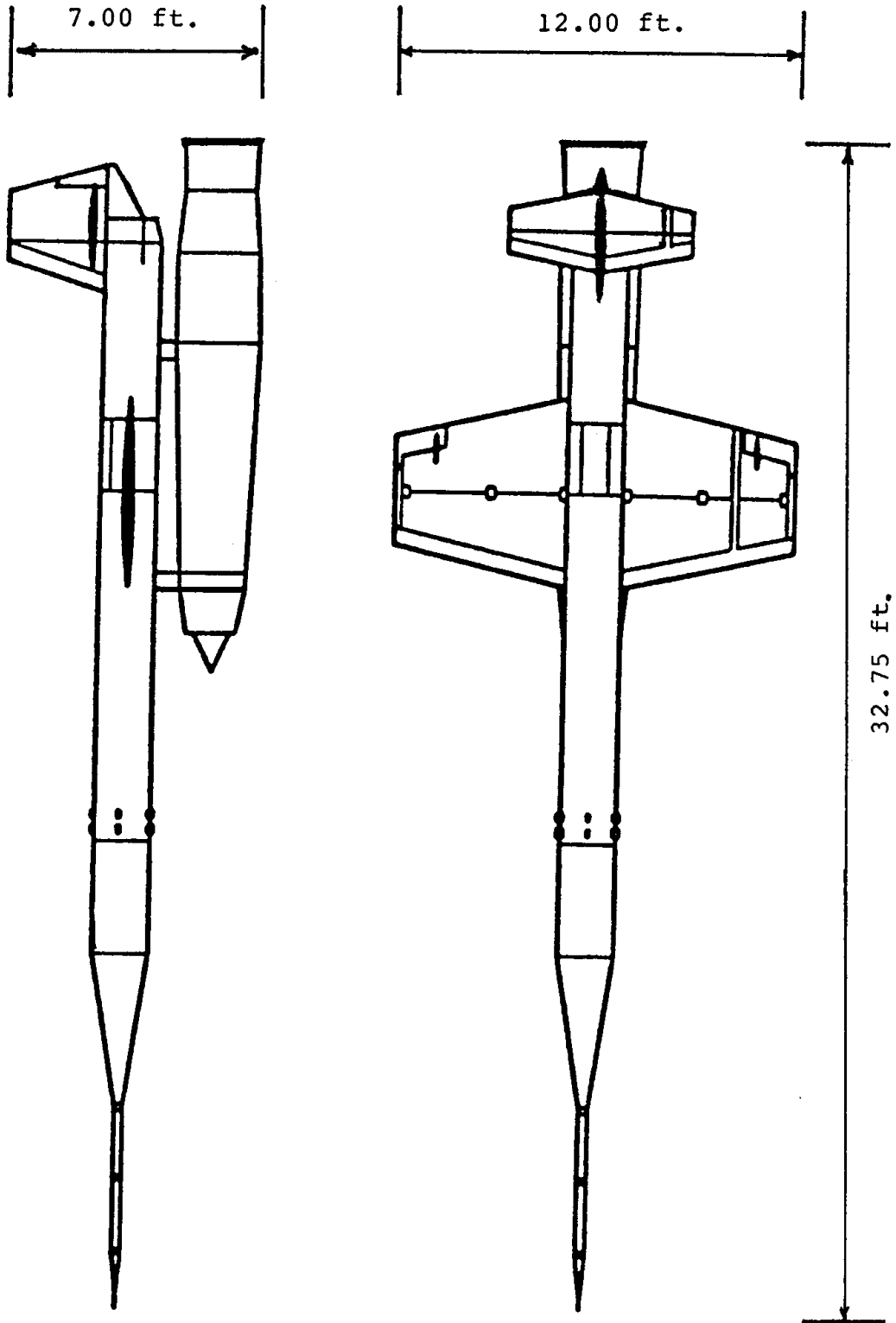


Figure 19



Figure 20



LOCKHEED X-7A-1 SUPERSONIC RESEARCH VEHICLE

cone-cylinder configuration.<sup>25</sup>

On February 24, 1949, a man-made object exceeded Mach 5--the demarcation mark of hypersonic flight--for the first time. That day, a two-stage Bumper WAC, consisting of a V-2 first stage joined to a WAC Corporal second stage, shot aloft from White Sands Proving Ground, New Mexico, on an upper atmospheric research investigation, reaching an altitude of 244 miles. On the way, it achieved a velocity of 5,150 mph. Obviously the ballistic rocket had potential as a hypersonic research tool, provided it was properly instrumented to return appropriate aerodynamic and heat transfer information. During the early 1950's, the NACA's Pilotless Aircraft Research Division (PARC) at Wallops Island, Virginia, made a number of contributions to hypersonic research using small multi-stage research rockets beginning in 1953. PARC's rockets consisted of variations on the Nike surface-to-air missile theme. On November 20, 1953, PARC flew a two-stage test vehicle carrying a small parabolic nose shape fabricated from Inconel alloy. The vehicle reached Mach 5.0, and telemetered a limited amount of valuable heat transfer data to a waiting ground station. PARC elaborated on this early test with subsequent work in 1954, and then created a four-stage hypersonic research rocket consisting of a combination termed the Nike-Nike-T40-T55. On October 14, 1954, seven years since Chuck Yeager first exceeded the speed of sound, this combination reached Mach 10.4 at 86,000 feet; after burnout, the last stage coasted to 219 miles altitude and impacted 400 miles downrange. It returned valuable heat transfer information, and detected a transition from turbulent to laminar flow as the flight Reynolds number reached 6.8 million. The fourth stage had a flared aft body for hypersonic stability (the drag of such a configuration being considered of little significance at the high altitudes that the vehicle operated), and was of steel and Inconel construction. Shortly after the Mach 10

flight, a group of Air Force and industry representatives visited the PARD to see if the NACA's work could be of assistance to the Air Force as it undertook development of the first generation of intercontinental and intermediate range ballistic missiles, typified by the Atlas and Thor programs. The service perceived an "intense need" for heat transfer data at velocities of approximately Mach 15, and hoped that PARD's efforts might produce near-term results beneficial to the Air Force. PARD's work was on a much slower schedule than desired by the Air Force and, accordingly, the service pursued its own research via the Lockheed X-17 program. However, it did support PARD's work by delivering suitable engines for the PARD vehicles, and thereafter, much beneficial interchange of ideas and results occurred between the technical staff of the Air Force and the NACA. Eventually, in August 1956, a NACA combination of the Honest John (as a first stage) joined to a Nike second stage, a Nike third stage, a Recruit fourth stage, and a T55 fifth stage reached Mach 17, though inflight separation of the instrumented nose from the rest of the fifth stage turned the flight into a spectacular though unproductive event. PARD continued its "mix and match" approach to hypersonic rocket development, and eventually, did much useful work on assessing the performance, heating characteristics, and behavior of blunt body reentry vehicles. However, the principle contributor to this field of inquiry was the Air Force, which sponsored the Lockheed X-17 program and a series of advanced reentry test vehicles flown on Thor-Able and Atlas boosters.<sup>26</sup>

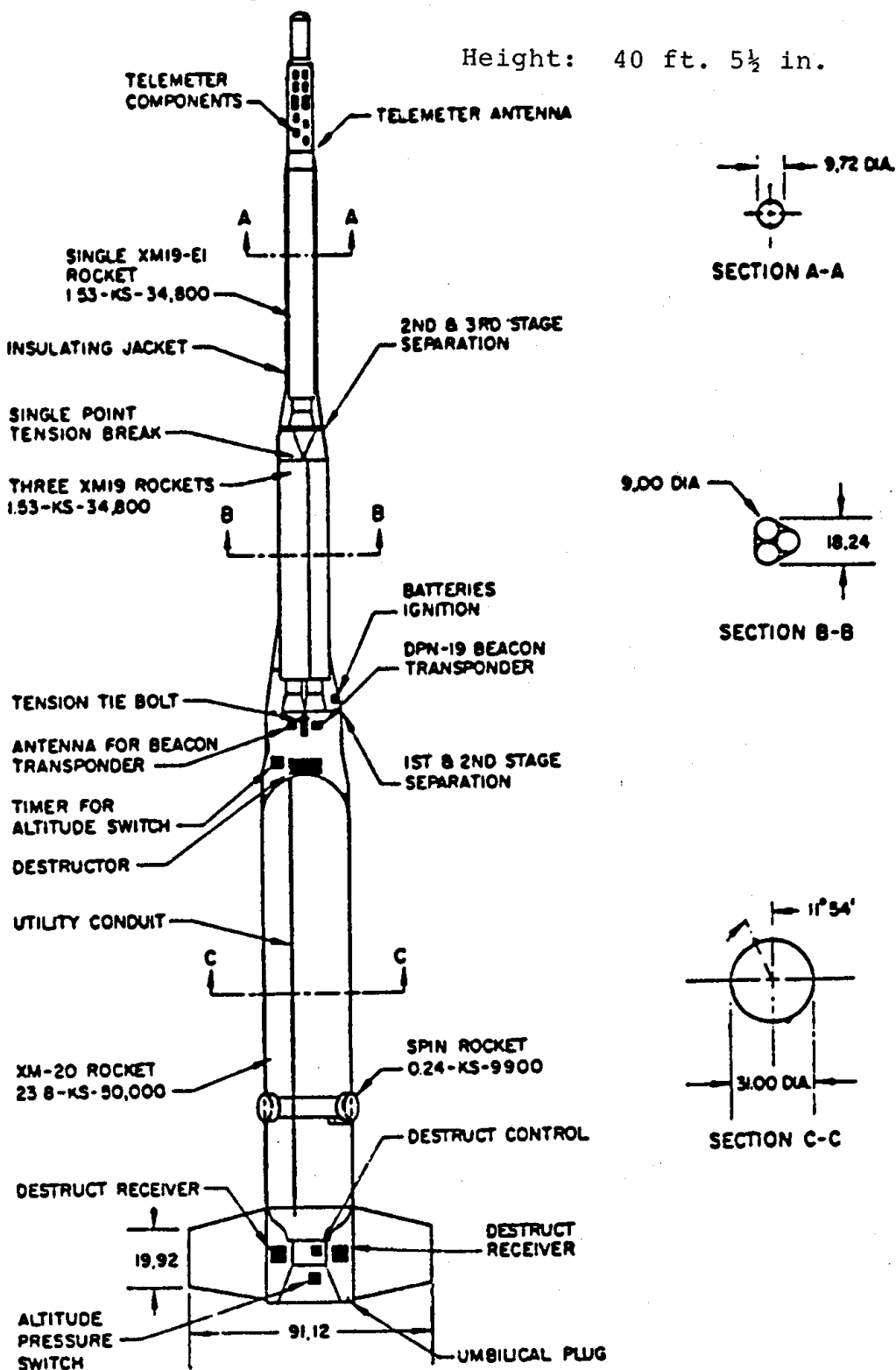
The Air Force had begun the X-17 program in January 1955 with contract award to Lockheed from the service's Ballistic Missile Division for a test vehicle that could boost reentry shapes to conditions typical to those expected to be encountered by reentering IRBM and ICBM warheads, namely Mach numbers of about 15, Reynolds numbers as high as  $30 \times 10^6$ , stagnation temperatures

between 15,000 and 20,000 degrees Fahrenheit, and heat transfer rates on the order of several thousand BTUs/sec/ft.<sup>2</sup> In analogous fashion to NACA's work, Lockheed utilized a mix-and-match approach, selecting a 50,000 lb thrust Thiokol XM-20 Sergeant solid-fuel engine for the first stage, a cluster of three Thiokol XM-19 Recruits (rated at 34,861 lbs thrust each) as the second stage, and finally, a single XM-19E1 (modified to produce 35,950 lb thrust) as the third stage. The shapely X-17 (Figure 21) utilized four tailfins to stabilize it during reentry as it descended into the lower atmosphere, and two small spin rockets affixed to the first stage to spin stabilize it during the early boost phase of flight at the rate of two revolutions per second. The X-17 reached an altitude of approximately 330,000 to over 500,000 feet, propelled by its first stage alone. After it reached apogee, it would follow a ballistic arc earthwards, all stages still connected. In order to properly simulate reentry temperature and Reynolds number conditions, the X-17 would descend well into the lower atmosphere before the first stage would separate and the second stage would fire, burning out in several seconds and falling away as the third stage boosted the nose cone shape to the desired reentry test conditions. Between April 17, 1956 and August 22, 1957, the Air Force fired twenty-six X-17's on reentry research studies, carrying a variety of blunt, paraboloid, conic, and hemispheric reentry shapes, including twelve tests (six apiece) of AVCO and General Electric reentry shape designs. The highest Mach number attained was Mach 14.4 (Flight 21, February 7, 1957); the highest Reynolds number achieved was 32 million, on Flight 2 (July 17, 1956). Six of the twenty-six launched failed to meet test objectives for reasons that ranged from spectacular (for example, blowing up after launch, or all stages firing straight up) to the mundane (telemetry failure during boost), giving the overall program a 77% success rate--not bad for an



Figure 21

Height: 40 ft. 5½ in.



LOCKHEED X-17 REENTRY RESEARCH SYSTEM

early missile test program, when one considers the state of rocketry at this time with the various Thors, Jupiters, Atlas's et. al., often wandering drunkenly off course and exploding up and down the coast.<sup>27</sup>

The urgency of the X-17 program can be seen in its near-frantic launch rate: 26 launches in 16 months, including no less than 17 in the first 8 months (April-December 1956). The urgency stemmed from the demands of the national ballistic missile program, moving into high gear even before Sputnik added its own transformational jolt. Advances in propulsion technology, guidance and control, and the physics of small-size thermonuclear weapons had made the ICBM a feasible concept in the early 1950's; H. Julian Allen's postulation of the blunt body reentry principle had opened the way to returning a functioning warhead through the atmosphere, but numerous technical questions remained, particularly ones involving the merits of a "heat sink" type design or an ablative design. The X-17 program, and the later Able Phase I, RVX-1, and RVX-2 programs addressed these questions and many others and generated a data base on hypersonic reentry that engineers applied to subsequent reentry shape design. While they did not contribute directly to hypersonic lifting reentry from space, they expanded the whole base of hypersonic technology to a significant degree by studies undertaken in these astrobolic programs, and they likewise permitted the "real world" comparison of theory, data gathered from ground research facilities such as shock tubes, and data gathered from actual flight vehicles hurtling through the atmosphere.

The study of reentry ballistics really started in the 1920's when astrophysicists looked at the conditions under which meteorites entered the earth's atmosphere from space. A group of German and British astrophysicists examined ablation (a condition in which a body entering the atmosphere dissipates heat through a

process whereby a portion of the exterior burns and vaporizes, carrying away the heat as the substance of the body is transformed into a gas) and the concept of a heat sink, whereby a highly heat-conductive body survives atmospheric entry because the conductive material absorbs the heat so that the overall temperature of the body never reaches its melting point. Meteorites experienced both. Metallic meteorites usually experienced heat sink effects during reentry, though the high heat flux of reentry often overwhelmed the ability of the metallic content to carry away heat from the exposed face to the interior; as a result, metallic meteorites usually fell to earth heavily pitted and fragmented. On the other hand, stone meteors typically exhibited ablation, a small portion of the shape vaporizing and enabling the rest to survive the rigors of atmospheric entry. Immediately after the Second World War, Dr Fritz Zwicky of the California Institute of Technology conceived a research project to examine "man-made meteors" ejected from captured V-2 missiles launched at White Sands; his test "meteors" were modified rifle grenades, but during one actual trial involving the firing of six grenades fitted with conical reentry bodies, ground instrumentation failed to detect any of these "meteors" streaking to earth, perhaps because they had failed to fire. In the early 1950's, following Allen's promulgation of blunt-body theory, little "hard" data on the environment affecting reentry shapes existed, and, as a result, the initial warheads developed for ICBM and IRBM purposes consisted of conservatively-designed large blunt-body shapes, typified by the Mark 2 reentry body for the Thor and Atlas missile developed by the Missile and Space Vehicle Department of the General Electric Corporation. Unlike lifting reentry spacecraft, which are compared on the basis of their lift-to-drag (L/D) ratio, non-lifting ballistic reentry shapes are compared on the basis of the parametric relationship  $W/C_D A$ , where

W is weight,  $C_D$  is the drag coefficient, and A is a representative cross-sectional area of the shape. A shape having a low  $W/C_D A$  in general is less streamlined, experiences more rapid deceleration, a steeper drop to the target, and a longer period of time from atmospheric entry to impact. A shape having a high  $W/C_D A$  is in general more streamlined, has a longer range, slower deceleration, and a briefer time from entry to impact. Typically, early ICBM and IRBM warhead proposals concentrated on low  $W/C_D A$  concepts, ideally suited for heat sink approaches. Later designs, more concerned with performance (as well as reducing reentry heat signature and the reaction time available to defenders), favored more streamlined ablation-cooled high  $W/C_D A$  shapes. Figure 22 shows a typical group of early heat-sink blunt body warhead designs studies by the AVCO Corporation. Figure 23 shows a range of GE designs from the low  $W/C_D A$  heat-sink Mark 2 through the research Able Phase I, RVX-1, RVX-2, and operational Mark 3, the latter (for its time) a high  $W/C_D A$  design.<sup>28</sup>

On August 8, 1957, the Army Ballistic Missile Agency fired a Jupiter C reentry research missile with an ablating nose cone (a one-third scale nose of the Jupiter IRBM) recovering the test shape after it flew a 1,200-mile IRBM trajectory. It was the first man-made object recovered from space. This test followed a less successful earlier launch in May, and a series of test-stand firing trials at the Huntsville Arsenal whereby candidate ablative materials had been exposed to the exhaust of rocket engines, in an effort to simulate the conditions of reentry. The next step belonged to the Air Force. To gather information for advanced reentry nose cone design, the Air Force (in conjunction with General Electric and AVCO) instituted three flight test materials research programs in December 1957 for the purpose of evaluating ablating design concepts. The three subsequently became known as Able Phase I, RVX-1, and RVX-2. General Electric's Missile and

Figure 22

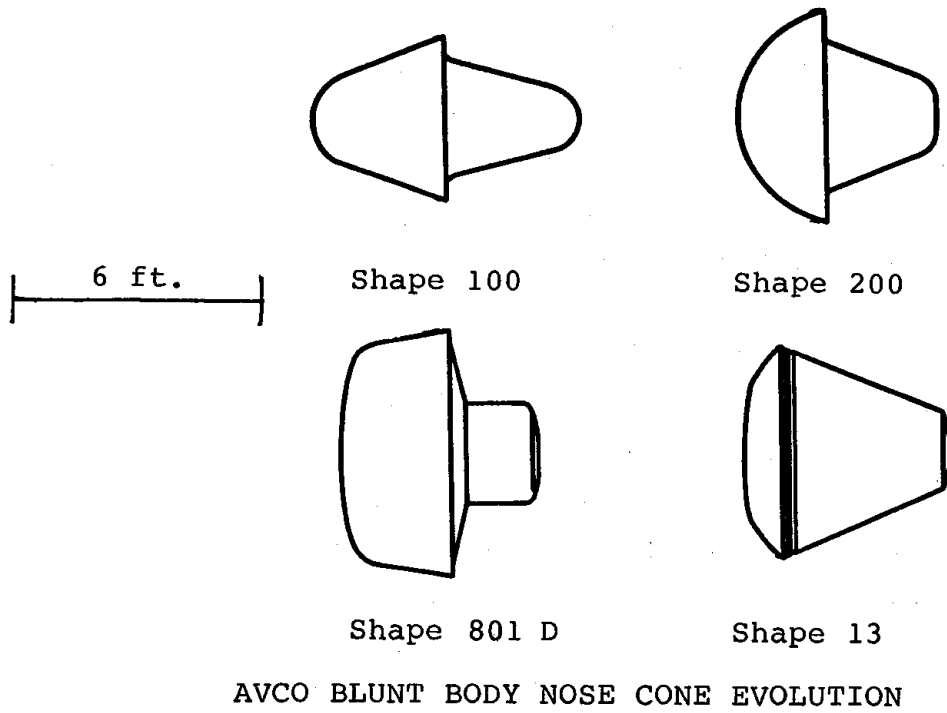
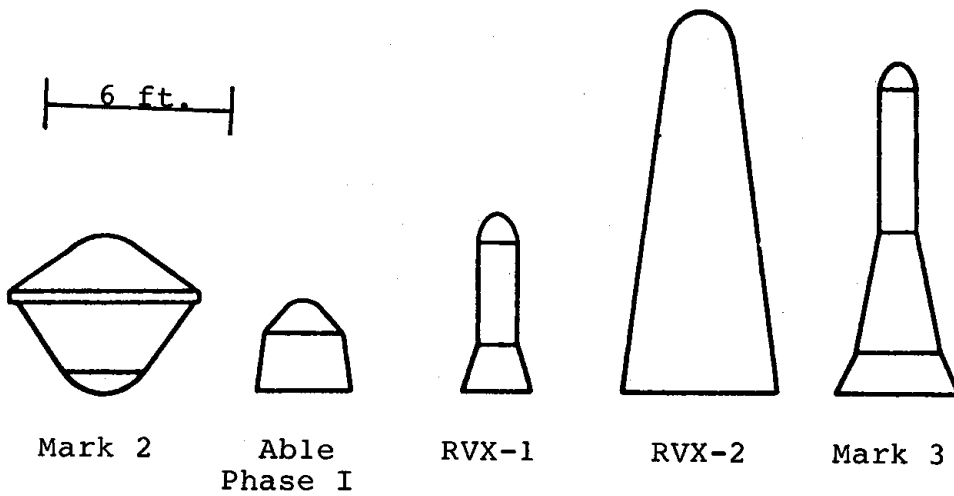


Figure 23



Space Division build the basic reentry vehicles, and the Air Force launched them on Thor-Able and Atlas boosters. By the end of the program in 1959, the box score was no recovered Able Phase I's out of two possible, 2 of 6 RVX-1's recovered, and 1 out of 3 RVX-2's recovered. Able Phase I, the smallest, was a biconic sphere three feet in diameter, weighing over 600 lbs and carrying a 701 lb instrument payload. In contrast, at the time of its reentry on July 21, 1959, the RVX-2, twelve feet long and five feet in diameter, was the largest object recovered from space, weighing over a ton. It had flown 4,385 nautical miles following launch from Cape Canaveral, and had survived a reentry at 15,000 mph before plunging into the sea at the end of a recovery 'chute near Ascension Island, 33 minutes after lift-off. With the exception of some of the RVX-1 shapes, all of the entry vehicles were built by General Electric. For RVX-1, a flared cylinder-conic-sphere design, GE and AVCO both furnished ablative test shapes permitting comparisons between the design approaches of both companies. The RVX-1 had a streamlined shape, a flared aft body for stability, was approximately five feet tall and two feet in base diameter, and weighed approximately 650 lbs including 260 lbs of instruments. Covered with sample ablative materials, the RVX-1's tests were highly successful; the shapes carried telemetry equipment, and, in addition, had tape recorders for playback of data acquired while the craft was in the period of ion sheath "blackout" during reentry. Of the two RVX-1's recovered, both a GE and an AVCO example survived--a fortunate opportunity for comparative analysis. The generalized RVX-1 design approach appeared on the operational Mark 3 warhead which was tested in October 1959, and placed in service on the Atlas in April 1960. RVX-1 also spawned the much larger RVX-2, a test program intended to assess a high  $W/C_D A$  warhead in the dynamic environment of an ICBM reentry. RVX-2, a tapered conic-sphere configuration,

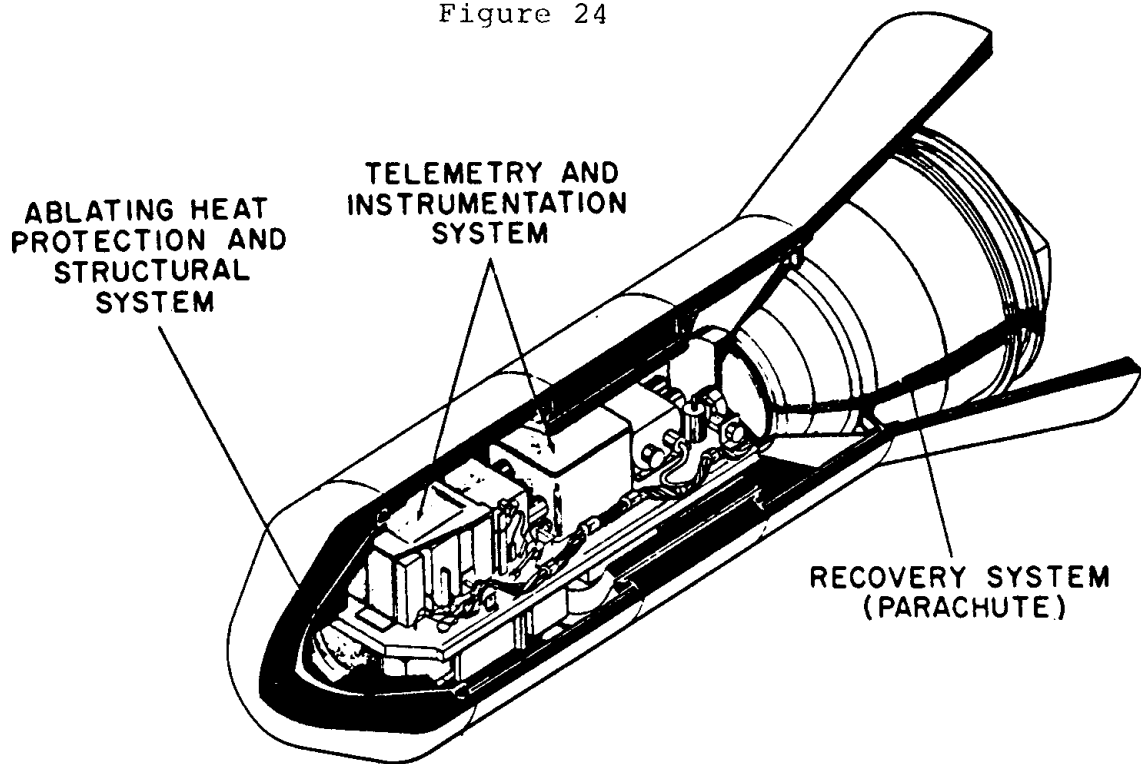
carried 510 lbs of instruments, and the success of the single successful RVX-2 flight spawned a successor program, the RVX-2A, as well as a short-lived attempt to create a special hypersonic aerodynamic RVX-2 test vehicle for the NASA (discussed subsequently by John Becker in Case Study III). The generalized RVX-2 shape subsequently appeared on the Titan II ICBM as the Mark 6 reentry vehicle. Figure 24 shows a comparison of the RVX-1 and RVX-2 vehicles in terms of their internal arrangement.<sup>29</sup>

As the preceding discussions have hopefully demonstrated, by the early 1960's a comprehensive amount of work related to hypersonic research had already been accomplished, much of it in the facilities world, and in related fields such as ballistic missile reentry studies. It is not accurate, of course, to suggest that this work enabled the subsequent accomplishment of hypersonic lifting reentry vehicle development, but it certainly would be accurate to state that this work added to a base of knowledge that enabled hypersonic vehicle designers to approach their tasks with ever-increasing levels of confidence. By the mid-1960's designers were abandoning the pure ballistic drop of returning spacecraft in favor of modest lift-to-drag ratios permitting limited maneuverability. While Mercury had been purely ballistic like the ICBM's and IRBM's before it, the two-man Gemini spacecraft produced a small amount of lift at hypersonic speeds, having a L/D of 0.25. The larger Apollo Command Module had a hypersonic L/D of 0.6, though, in practice, because of the precision returns it flew, the crews never needed to call upon the CM for more than an L/D of 0.31 on any of its flights. To be sure, major advances occurred after the early 1960's in facilities development and free-flight hypersonic research. Advanced ballistic and maneuvering reentry vehicles contributed additional information, much of it related to the actual development of weaponry and military capabilities. For example, in the late

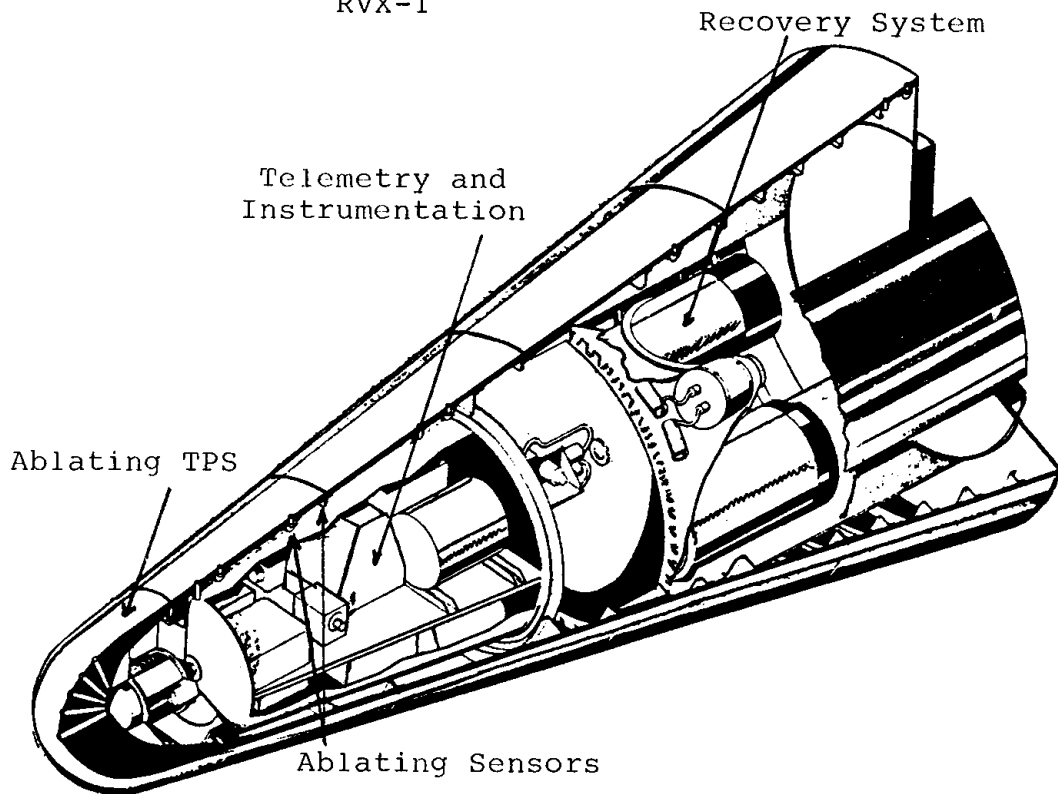




Figure 24



RVX-1



RVX-2

1960's, several influential maneuvering reentry vehicle research programs were undertaken that subsequently greatly influenced reentry shape design technology. Most notable of these was the BGRV (for Boost-Glide Reentry Vehicle) program. BGRV was an approximately 2,000-lb slender cone with an overall length of 22 ft 11 in and a base diameter of 2 ft 4 in launched over the Western Test Range by an Atlas booster. On February 26, 1968, a BGRV maneuvered through the atmosphere during a Mach 18 reentry using aft trim flares and a reaction jet system commanded by an on-board inertial guidance unit. After completing reentry, it landed near Wake Island.<sup>30</sup> In conjunction with Canada, the U.S. Army's Ballistic Research Laboratories at Aberdeen, Maryland, sponsored development and use of large cannon for hypersonic shape research on aerodynamic studies of missile nose cones; in one Canadian test, a modified 16 in naval cannon fired a test shape to Mach 8 (8,700 ft/sec, compared to 2,800 ft/sec for a standard 16 in shell).<sup>31</sup> But this falls largely outside the scope of this study and the intent of this text, which has been to offer the reader a perspective on the development of hypersonic knowledge and "hardware" to the point where engineers began actual development of hypersonic aircraft and lifting reentry spacecraft. It is appropriate now to leave the environment of the late 1950's for the first case study; a discussion of a vehicle that was neither a true spacecraft nor a "mere" airplane, but rather a bridge-gapper: the North American X-15. Even now it must be considered the most ambitious research aircraft program ever undertaken and fulfilled.

## NOTES

1. For Max Valier, see I. Essers, Max Valier: ein Vorkämpfer der Weltraumfahrt, 1895-1930 (Dusseldorf: VDI-Verlag GmbH, 1968), translated by the National Aeronautics and Space Administration as NASA TT F-664, Max Valier: A Pioneer of Space Travel (Washington, D.C.: NASA, 1976), pp. 81-97, 130-135, 248. See also Max Valier, Der Vorstoss in den Weltenraum: eine technische Möglichkeit (Munich: Verlag von R. Oldenbourg, 1924). For the work of other pioneers mentioned, see A.A. Blagonravov, ed., K.E. Tsiolkovskiy: Sobraniye Sochineniy, Tom II Reaktivnyye Letatel'nyye Apparaty (Moscow: Izdatel'stvo Akademii Nauk SSSR, 1954), translated by the National Aeronautics and Space Administration as NASA TT F-237, Collected Works of K.E. Tsiolkovskiy, v. II Reactive Flying Machines (Washington, D.C.: NASA, 1965), pp. 528-530; Robert H. Goddard, "A Method of Reaching Extreme Altitudes", in Esther C. Goddard and G. Edward Pendray, eds., The Papers of Robert H. Goddard, v. I: 1898-1924 (New York: McGraw-Hill Book Company, 1970), pp. 337-406; Herman Oberth, Die Rakete zu den Planetenräumen (Munich: Verlag von R. Oldenbourg, 1923). General introductions to early spacecraft conceptions can be found in Noel Deisch, "Navigation of Space in Early Speculation," Popular Astronomy (February 1930), pp. 73-88; W.R. Maxwell, "Some Aspects of the Origins and Early Development of Astronautics", British Interplanetary Society Journal (Sept-Dec 1962), pp. 415-425; and G. Edward Pendray, "Pioneer Rocket Development in the United States", in Eugene M. Emme, ed., The History of Rocket Technology: Essays on Research, Development, and Utility (Detroit: Wayne State University Press, 1964), pp. 19-20.

2. Werner Schulz, "Walter Hohmann's Contributions Towards Space Flight: An Appreciation on the Occasion of the Centenary of His Birthday", paper presented at the XXXth Congress, International Astronautical Federation, Munich, FRG, Sept 21, 1979; Walter Hohmann, Die Erreichbarkeit der Himmelskörper (Munich: Verlag von R. Oldenbourg, 1925); translated by the National Aeronautics and Space Administration as NASA TT F-44, The Attainability of Heavenly Bodies (Washington, D.C.: NASA, 1960).

3. Eugen Sänger, Raketenflugtechnik (Munich: Verlag von R. Oldenbourg, 1933), translated as NASA TT F-223, Rocket Flight Engineering (Washington, D.C.: NASA, 1965; Eugen Sänger, "Neuere Ergebnisse der Raketenflugtechnik", Flug: Zeitschrift für das gesamte Gebiet der Luftfahrt (December 1934), pp. 10-22; Irene Sänger-Bredt, "The Silver Bird Story: A Memoir", in R. Cargill Hall, ed., Essays of the History of Rocketry and Astronautics: Proceedings of the Third Through the Sixth History Symposia of the International Academy of Astronautics, v. I (Washington, D.C.: NASA, 1977), pp. 195-228.

4. Eugen Sänger and Irene Bredt (later Irene Sänger-Bredt), Über einen Raketenantrieb für Fernbomber, Deutsche Luftfahrtforschung UM 3538 (Ainring: DFS, Aug 1944), translated by the Naval Technical Information Branch, Bureau of Aeronautics, United States Navy, as Translation CGD-32, A Rocket Drive for Long-Range Bombers (1952); Sänger-Bredt, "Silver Bird", pp. 209-212.
5. Wernher von Braun, "German Rocketry", in Arthur C. Clarke, ed., The Coming of the Space Age (New York: Meredith Press, 1967), pp. 54-55; Frederick I. Ordway and Mitchell R. Sharpe, The Rocket Team (New York: Thomas Y. Crowell Publishers, 1979), pp. 54-57; Walter Dornberger, V-2 (New York: The Viking Press, 1958), pp. 250-251; Rowland F. Pocock, German Guided Missiles of the Second World War (New York: Arco Publishing Company, 1967), pp. 98-99. Henry Friedman, Summary Report on A-4 Control and Stability, F-SU-2152-ND (Dayton OH: HQ Air Materiel Command Technical Intelligence, June 1947), pp. 238-240. See also Wasserbau-Versuchsanstalt Kochelsee GmbH, Die Aerodynamische Entwicklung der Fernrakete A9 (A4b), Archiv Nr. 190 (Kochel: WVA, July 10, 1945); and the A9/A-10 files, Air Force Museum, Wright-Patterson Air Force Base, Ohio; transcript of interview of Dr Wilhelm Raithel by Dr. John F. Guilmartin, July 25, 1984, in the files of the NASA Lyndon B. Johnson Space Center History Office. I wish to note the assistance of Dr. David Compton, Janet Kovacevich, Debbie Griggs, and Betty Chadwick of the JSC History Office.
6. See Walter C. Williams and Hubert M. Drake, "The Research Airplane: Past, Present, and Future", Aeronautical Engineering Review (January 1958), pp. 36-41; Kenneth S. Kleinknecht, "The Rocket Research Airplanes", in Eugene M. Emme, The History of Rocket Technology, pp. 189-211; Richard P. Hallion, "American Rocket Aircraft: Precursors to Manned Flight Beyond the Atmosphere", paper presented at the XXVth Congress, International Astronautical Federation, Amsterdam, The Netherlands, Oct 4, 1974; Richard P. Hallion, Supersonic Flight: Breaking the Sound Barrier and Beyond (New York: The Macmillan Company, 1972).
7. See, for example, Williams and Drake, "The Research Airplane", and Kleinknecht, "The Rocket Research Airplanes", passim.
8. John V. Becker, "The X-15 Program in Retrospect", Raumfahrtforschung (March-April 1969), p. 45. The "Sänger grab" attempt is briefly discussed in Sänger-Bredt, "Silver Bird", p. 215. Hsue-shen Tsien, "Instruction and Research at the Daniel and Florence Guggenheim Jet Propulsion Center", Journal of the American Rocket Society, No. 1 (June 1950), p. 63.
9. Aircraft Panel, USAF Scientific Advisory Board, "Some Remarks

of the Aircraft Panel on New Technical Developments of the Next Ten Years", (1 Oct 1954), pp. 2-4, 6-9.

10. Daniel S. Greenberg, The Politics of Pure Science (New York: The New American Library, 1969), p. 273; Aerospace Vehicles Panel on Prototypes, Hypersonic Technology, and Research Aircraft, USAF Scientific Advisory Board, "Report", (26-27 June 1968), p. 6.

11. Hugh L. Dryden, "Supersonic Travel Within the Last Two Hundred Years", The Scientific Monthly, LXXXVIII, No. 5 (May 1954), p. 293; Theodore von Kármán with Lee Edson, The Wind and Beyond: Theodore von Kármán, Pioneer in Aviation and Pathfinder in Space (Boston: Little, Brown, 1967), pp. 219-222, R. Smelt, "A Critical Review of German Research on High-Speed Airflow", Journal of the Royal Aeronautical Society, 50, n. 432, pp. 899-934; memo, Dr. Frank L. Wattendorf to Brig Gen Franklin O. Carroll, "Army Air Force Scientific Advisory Group Mission to European Theater of Operations (ETO)", (June 1945), in Arnold Engineering Development Center History Office files; for the transfer of the Kochel tunnels to NOL, see R.J. Seeger, "Research and Development in the NOL Aeroballistic Research Facility, 1946-1951; Philosophy of", NOL, 30 May 1951 (copy transmitted to author by Leon Schindel, 7 January 1987); Frank L. Wattendorf, A Chronology of the Background and Early History of the Arnold Engineering Development Center, 1938-1949 (Tullahoma TN: AEDC, 1986), pp. 8-9, 13, 15, 18; Donald D. Baals and William R. Corliss, Wind Tunnels of NASA, SP-440 (Washington, D.C.: NASA, 1981), pp. 56-57; Julius Lukasiewicz, Experimental Methods of Hypersonics (New York: Marcel Dekker, Inc., 1973), p. 26; A.J. Eggers and George J. Nothwang, The Ames 10- by 14-Inch Supersonic Wind Tunnel, TN-3095 (Washington, D.C.: NACA, January 1954); H. Guyford Stever and Kenneth C. Rathbun, Theoretical and Experimental Investigation of Condensation of Air in Hypersonic Wind Tunnels, TN-2559 (Washington, D.C.: NACA, November 1951), pp. 25-57.

12. Baals and Corliss, pp. 83, 85-97, 94-95; Lukasiewicz, pp. 26-27; R.N. Cox, "Experimental Facilities for Hypersonic Research", in Antonio Ferri, D. Kuchemann, and L.H.G. Sterne, eds., Progress in Aeronautical Sciences, III (New York: Pergamon Press, 1962), p. 162; Forrest E. Gowen and Vaughn D. Hopkins, "A Wind Tunnel Using Arc-Heated Air for Mach Numbers from 10 to 20," in Krill, pp. 27-38; Edwin P. Hartman, Adventures in Research: A History of Ames Research Center, 1940-1965, NASA SP-4302 (Washington, D.C.: NASA, 1970), pp. 242-243.

13. Lukasiewicz, pp. 27-33; Cox, pp. 151-152.

14. Baals and Corliss, p. 84; Cox, pp. 157-159; Lukasiewicz, pp. 34-37; James F. Martin, George R. Duryea, and Leroy M. Stevenson, "Instrumentation for Force and Pressure Measurements in a

- Hypersonic Shock Tunnel", in Krill, pp. 145-164.
15. Baals and Corliss, p. 84; Cox, pp. 161-162; Lukasiewicz, pp. 37-44; J.A. van der Blik, "Further Development of Capacitance- and Inductance-Driven Hotshot Tunnels", in Krill, pp. 47-63; Julius Lukasiewicz, L.J.D. Whitfield, and R. Jackson, "Status of Development of Hotshot Tunnels at the AEDC", in W.C. Nelson, ed., The High Temperature Aspects of Hypersonic Flow (New York: Pergamon Press, 1964) passim.
  16. John S. Rinehart, "Some Historical Highlights of Hypervelocity Research", in University of Denver-Denver Research Institute and Institute of the Aeronautical Sciences, eds., Proceedings of the National Symposium on Hypervelocity Techniques (New York: Institute of the Aeronautical Sciences, 1960), pp. 4-8; Cox, pp. 163-171; Lukasiewicz, pp. 45-50.
  17. Alvin Seiff, "A Free Flight Wind Tunnel for Aerodynamic Testing at Hypersonic Speeds", NACA Report 1222, in NACA, 44th Annual Report of the NACA for 1955 (Washington, D.C.: NACA, 1957), pp. 381-385; Hartman, pp. 234-238.
  18. Stanford E. Neice, James A. Carson, and Bernard E. Cunningham, Experimental Investigation of the Simulation of Atmospheric Entry of Ballistic Missiles, NACA RM A57126 (Washington, D.C.: NACA, 12 Dec 1957); Hartman, p. 238; Cox, pp. 166-168.
  19. Lukasiewicz, p. 243.
  20. Ibid., pp. 243-244.
  21. Ibid., p. 246
  22. Ibid., p. 250.
  23. Ibid.
  24. Wesley E. Messing, Leonard Rabb, and John H. Disher, Preliminary Drag and Heat-Transfer Data Obtained from Air-Launched Cone-Cylinder Test Vehicle Over Mach Number Range from 1.5 to 5.18, NACA Rm E53I04 Washington, D.C.: NACA, 16 Dec 1953), passim.
  25. Jay Miller, The X-Planes: X-1 to X-29 (Marine on St. Croix, MN: Specialty Press, 1983), pp. 69-73.
  26. Joseph A. Shortal, A New Dimension: Wallops Island Flight Test Range: The First Fifteen Years, Ref. Pub. 1028 (Washington, D.C.: NASA, 1978), pp. 375-382, 441-447, 507-522, 567-571; Eugene M. Emme, Aeronautics and Astronautics: An American Chronology of

Science and Technology in the Exploration of Space, 1915-1960  
(Washington, D.C.: NASA, 1960), p. 61.

27. "Re-entry Research: The Lockheed X-17", Flight (Feb. 6, 1959), p. 181; Miller, The X-Planes, pp. 121-123.

28. Rinehart, pp. 4-5; H.G. Lew, S.M. Scala, and G.W. Sutton, "Nose Cones: The Case for Ablation", in General Electric, Heat Protection for Re-Entry Vehicles, (n.p.: General Electric, 1959), p. 5, copy in C1 SM-65 (RVX-2)/his file, Air Force Museum.

29. See a comprehensive collection of materials in the Air Force Museum's C1 SM-65 (RVX-2)/his file, including General Electric, Re-entry Vehicles: Man-made Meteors, (n.d.), passim; Ltr., Marven R. Whipple to Royal D. Frey, 14 Sep 1964 and enclosure; General Electric, Thor-Able and Atlas Re-Entry Recovery Programs (n.d.)/passim; General Electric, Ablation Beats the Heat Barrier (1960), passim; and Mark Morton, Progress in Re-Entry-Recovery Vehicle Development (n.p.: General Electric, 2 Jan 1961), pp. 2-33. See also Wernher von Braun, "The Redstone, Jupiter, and Juno", in Emme, History of Rocket Technology, pp. 113-114.

30. Actual BGRV program results are still classified. This material is from a letter, Lt Col C. Duke Shearin (SAMSO Information Office) to Royal Frey (AF Museum), 17 Nov 1972, in the BGRV file, AF Museum archives. A classified summary report is in the classified documentation holdings of the AF Museum. Additionally, the museum has an unflown BGRV in its collections. Qualified readers having a need-to-know are advised to consult the museum's summary report as well as the large amount of classified documentation on the program that is maintained by the History Office, Air Force Space Division, Los Angeles Air Force Station, California; and the History Office, Ballistic Missile Office, Norton AFB, California. For a general discussion of BGRV and numerous other reentry study programs of the 1960's, readers may consult Michael P. London's "Advanced Strategic Missiles", Space/Aeronautics (June 1968), pp. 58-69. In a related vein, readers may find of interest a summary data book prepared by the Aeronautic Division of the Philco Corporation in support of the Air Force-sponsored FATE fuzing and arming test program, which involved reentry tests (including ground impact) of a slender cone (nose radius to base radius ratio of 1:28) having phenolic silica or phenolic carbon heat shields. Nine tests were held before program termination in 1969, using an Athena booster and involving ground impacts as high as 9,000 mph (Mach 11.8). While not per se hypersonic aerodynamic tests, such work did add to the general hypersonic knowledge base. See L.E. Brown and L.K. Glassen, FATE: Fuzing and Arming Test and Evaluation Program, U-3653 (Newport Beach CA: Philco, July 1966), passim.

31. Julius Lukasiewicz, "Canada's Encounter with High-Speed Aeronautics", Technology and Culture, XXVII, No. 2 (Apr 1986), pp. 249-251.



CASE I

TRANSITING FROM AIR TO SPACE:

THE NORTH AMERICAN X-15

by

Robert S. Houston

Richard P. Hallion

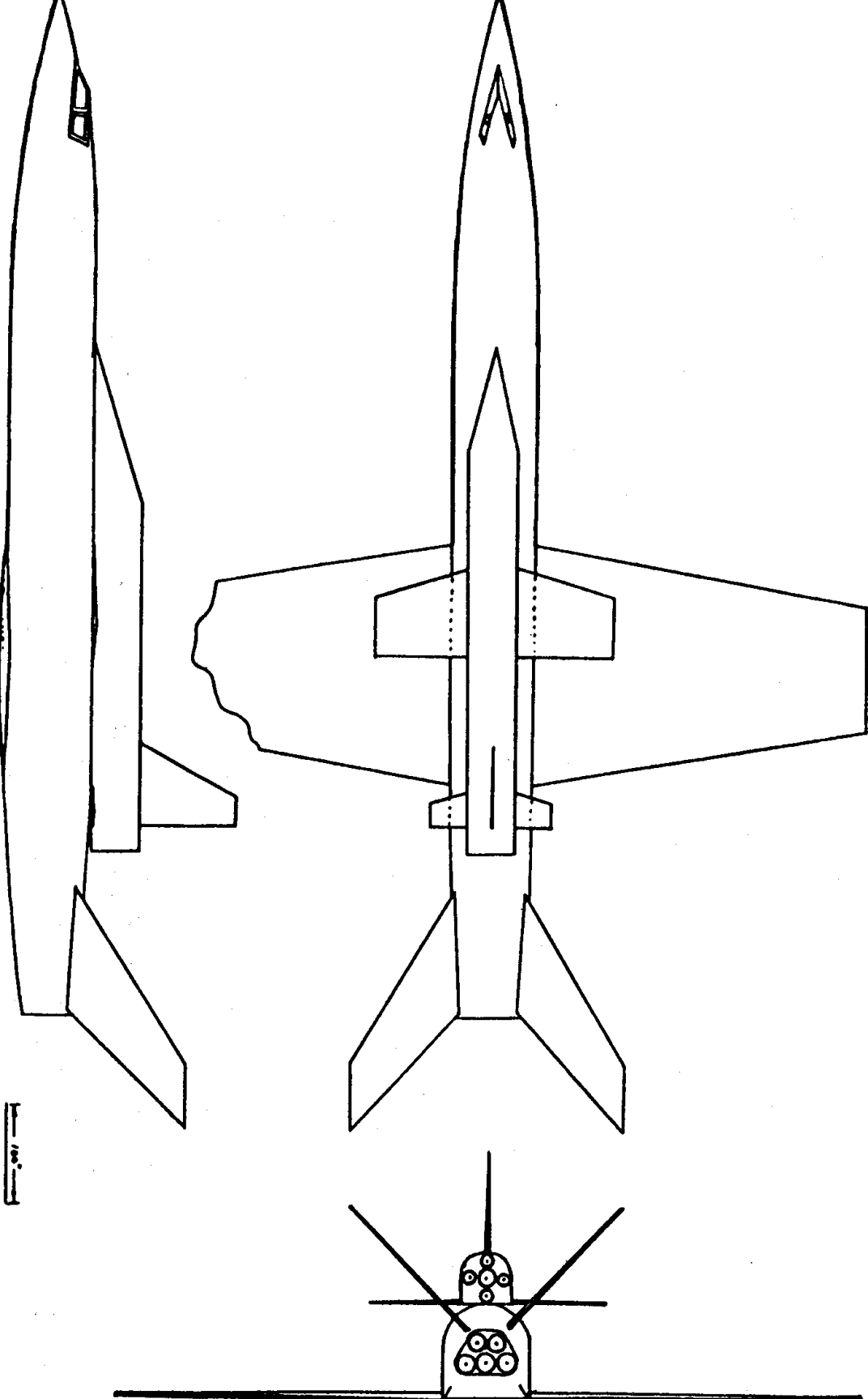
Ronald G. Boston

## EDITOR'S INTRODUCTION

The first call for an X-15-class research vehicle came from Robert J. Woods, a colleague of Walter Dornberger at Bell, during a meeting of the prestigious NACA Committee on Aerodynamics on October 4, 1951. He reiterated his support for such a vehicle during subsequent meetings and, as a result, the NACA committee passed a motion on June 24, 1952 that charged the agency to expand its research aircraft program to include studying the problems of manned and unmanned flight at altitudes between 12 and 50 miles, and velocities of Mach 4 to Mach 10, as well as devoting "a modest effort" to study exoatmospheric flight from Mach 10 to escape velocity. The major NACA field centers exchanged various paper plane proposals. NACA engineers L. Robert Carman and Hubert Drake of the High-Speed Flight Station drew up configurations for Mach 3+ launch aircraft carrying small hypersonic research aircraft including, in August 1953, a five-phase proposal culminating in the design of an orbital air-launched hypersonic boost-glide winged vehicle. The NACA shelved this bold proposal as too futuristic, which it was; its advocacy of a "two-stage to orbit" research vehicle was one of the earliest of the "piggyback" concepts predating the current Space Shuttle. The NACA, like other federal and private organizations, favored a more modest approach. In October 1953, the Air Force's Scientific Advisory Board recommended development of a Mach 5-7 research aircraft, and at the same time, the Office of Naval Research had funded the Douglas Aircraft Corporation to study the feasibility of a Mach 7+ rocket-propelled research airplane, informally referred to as the D-558-3.<sup>1</sup>

During 1954, the NACA, in partnership with the Air Force and Navy, further explored the hypersonic aircraft concept. The agency's Langley laboratory (later NASA's Langley Research Center)

Figure 5. — Phase II airframe mounted on launch vehicle



2/10  
12/12

AN EARLY AMERICAN HYPERSONIC AIRCRAFT/ORBITER PROPOSAL: THE DRAKE-CARMAN COMPOSITE RESEARCH AIRCRAFT PROPOSAL OF 1953.

had formed a hypersonic study team comprised of chairman John V. Becker, Maxime Faget, Thomas Toll, N. F. Dow, and J. B. Whitten, and this group subsequently evolved a baseline design that closely resembled the ultimate X-15 configuration. Their conception incorporated Inconel alloy heat-sink construction, had a cruciform tail configuration, a wedge vertical fin for increased directional stability, and similar weights and specifications as the final aircraft. In December 1954, the NACA, Air Force, and Navy agreed to undertake joint development of the proposed hypersonic research aircraft, and in January 1955 it received the designation X-15. That same month, the Air Force (which administered the design and construction phases of the project) held the first briefings for potential contractors. This culminated in a competition between North American, Bell, Douglas, and Republic, which North American won on September 30, 1955. The Bell entry, which featured a novel form of "double-wall" construction, reflected the firm's obsession with Sänger-like boost-gliders (indeed, in April 1952, Bell's Dornberger had journeyed to France in a vain attempt to convince Sänger and his wife to join the company), and had no real hope of winning. The subsequent technical development of the North American X-15 went smoothly, with the exception of its rocket powerplant, which generated great concern before it, too, reached fruition.<sup>2</sup>

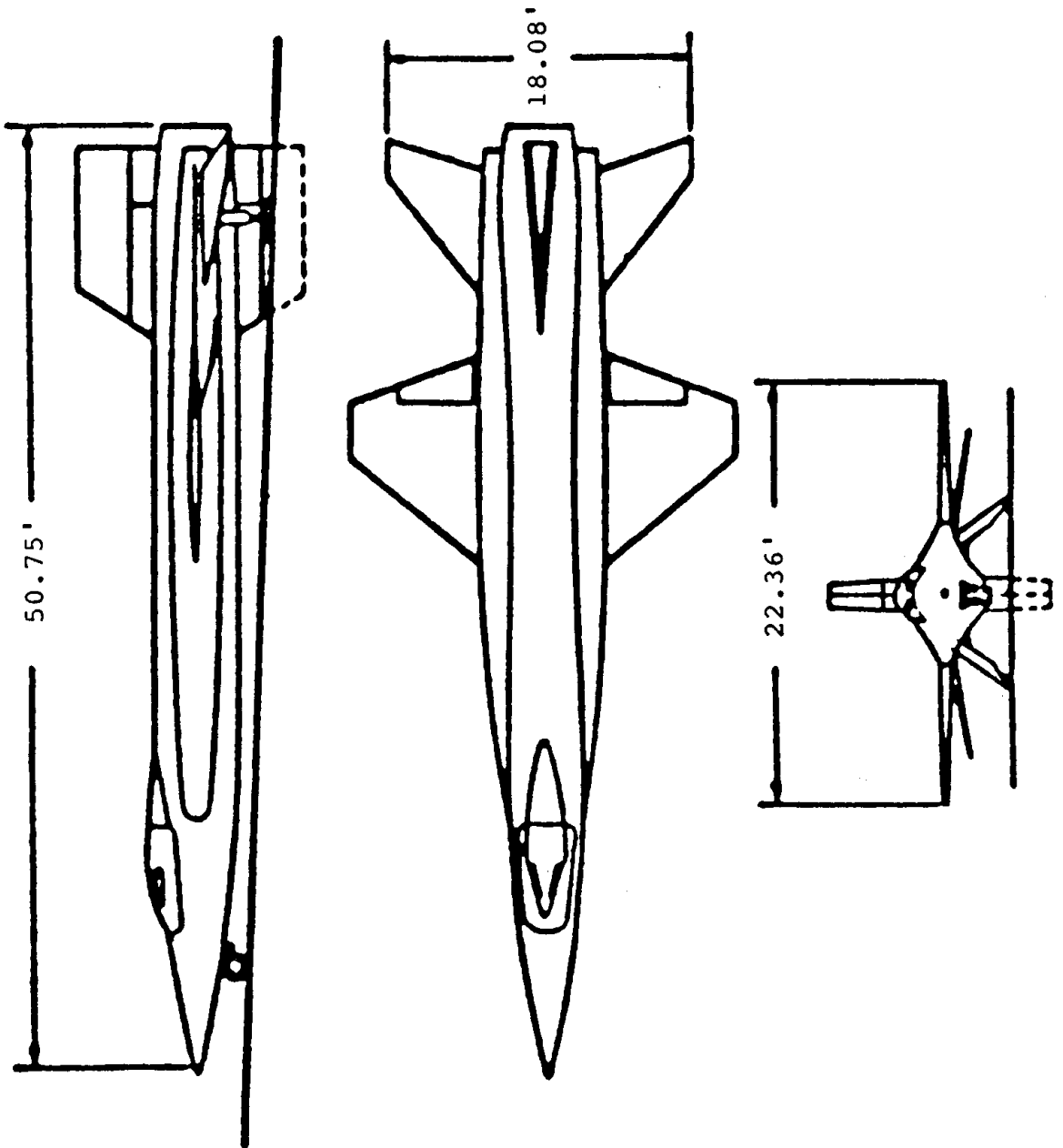
The X-15, "Round Two" in the parlance of the NACA, had many features that separated it from the previous rocket research aircraft and placed it at an intermediate level between the purely supersonic aircraft (such as the X-1) and the purely winged reentry vehicles (like the proposed "Round Three" Dyna-Soar and the eventual Space Shuttle). For example, it incorporated a reaction control system of hydrogen peroxide rocket thrusters for keeping the aircraft under control at high altitudes; the pilot wore a full-pressure pilot protection suit (the Clark MC-2) having provisions for physiological monitoring. It was the first flight vehicle to blend the application of hypersonic aerodynamic theory to an actual aircraft. It incorporated high temperature seals and lubricants, and had a "Q-ball" flow direction sensor capable of operating with

stagnation air temperatures of 3500 deg. F. The pilot relied on inertial flight data systems developed especially for operation under space-like conditions. The X-15's Inconel structure was the first reusable super-alloy structure capable of withstanding the temperatures and thermal gradients of hypersonic reentry. Subsequently, during its flight program, the X-15 spawned development and application of a refurbishable ablative heat-protection system (the Martin MA-25S).<sup>3</sup>

The X-15 spanned 22 ft. 4 in., and had a length of 50 ft. 9 in. It utilized a Thiokol (Reaction Motors Division) XLR-99 throttleable rocket engine, burning a mixture of anhydrous ammonia and liquid oxygen. (Delays in the development of this engine forced North American to install two XLR-11 engines in the X-15s during 1959, before beginning the research program, for purposes of checking out the aircraft and its systems; the first XLR-99 flight did not come until November 15, 1960). The three X-15 aircraft quickly established a number of speed and altitude marks, which often obscured the less glamorous but occasionally more important work they accomplished in mapping out the frontiers of hypersonic flight. By the end of 1961, the X-15 had achieved its Mach 6 design speed, and had reached altitudes in excess of 200,000 feet. On August 22, 1963, NASA research pilot Joseph Walker reached 354,200 feet in the third X-15 aircraft, still a record for winged vehicles. X-15 testing revealed a number of interesting conditions about hypersonic flight, including the discovery that hypersonic boundary layer flow is turbulent and not laminar, that turbulent heating rates were lower than predicted by theory, that supersonic skin friction was likewise lower than predicted, that local surface irregularities generated hot spots (in one notable case, aerodynamic heating caused buckling of the wing skin behind leading edge heat expansion slots), and that the cruciform tail configuration created a serious adverse roll problem at high angles of attack during atmospheric reentry (NASA cured this by removing the jettisonable lower half of the craft's ventral fin). The flights demonstrated that a pilot could successfully transition from aerodynamic to



Figure 2



THE X-15 ROCKET RESEARCH AIRPLANE

reaction controls and back again, function in a weightless environment (which became an academic question after Vostok and Mercury), control a rocket-boosted vehicle during atmospheric exit, and use energy management techniques to make a hypersonic/supersonic reentry and glide approach to a precision landing. The X-15 eventually made reentries at angles of attack up to 26 deg. and at flightpath angles as low as -38 degrees at Mach 6 flight speeds.<sup>4</sup>

As with the previous "Round One" rocket research airplanes, the X-15 was air-launched, being dropped from a modified Boeing B-52 jet bomber. The flights were made over a specially instrumented 485-mile-long 50-mile-wide flight test corridor stretching from Nevada to Edwards Air Force Base in California. Following a landing accident with the second X-15, the Air Force and NASA authorized the manufacturer to modify it as a special testbed for NASA's planned Hypersonic Ramjet Experiment. North American lengthened the aircraft, making numerous modifications to it, and added provisions for two large jettisonable external tanks. Thus equipped, the aircraft, designated the X-15A-2, was capable of Mach 7 flight speeds, if equipped with a proper thermal protection system. NASA finally selected Martin to develop a suitable ablator, and that company derived the MA-25S, an ablator mix consisting of a resin base, a catalyst, and a glass bead powder. Hopes that such ablators could enable designers to build refurbishable spacecraft that could be stripped and recoated after each flight proved ill-founded, however. On October 3, 1967, the X-15A-2 attained Mach 6.72 (over 4,520 mph), while piloted by Air Force Maj. William J. Knight. Unfortunately, the plane landed in extremely worn condition--a dummy ramjet had separated off the craft, in fact--and the ablator would have required massive cleanup efforts prior to reapplication. North American repaired the craft and returned it to NASA, but it never flew again. The third X-15 made a number of notable high-altitude flights above 50 miles. Unfortunately, this aircraft was lost, together with pilot Michael J. Adams, on November 15, 1967. The first X-15 completed its last flight, the 199th flight for the type, on October 24, 1968.<sup>5</sup>

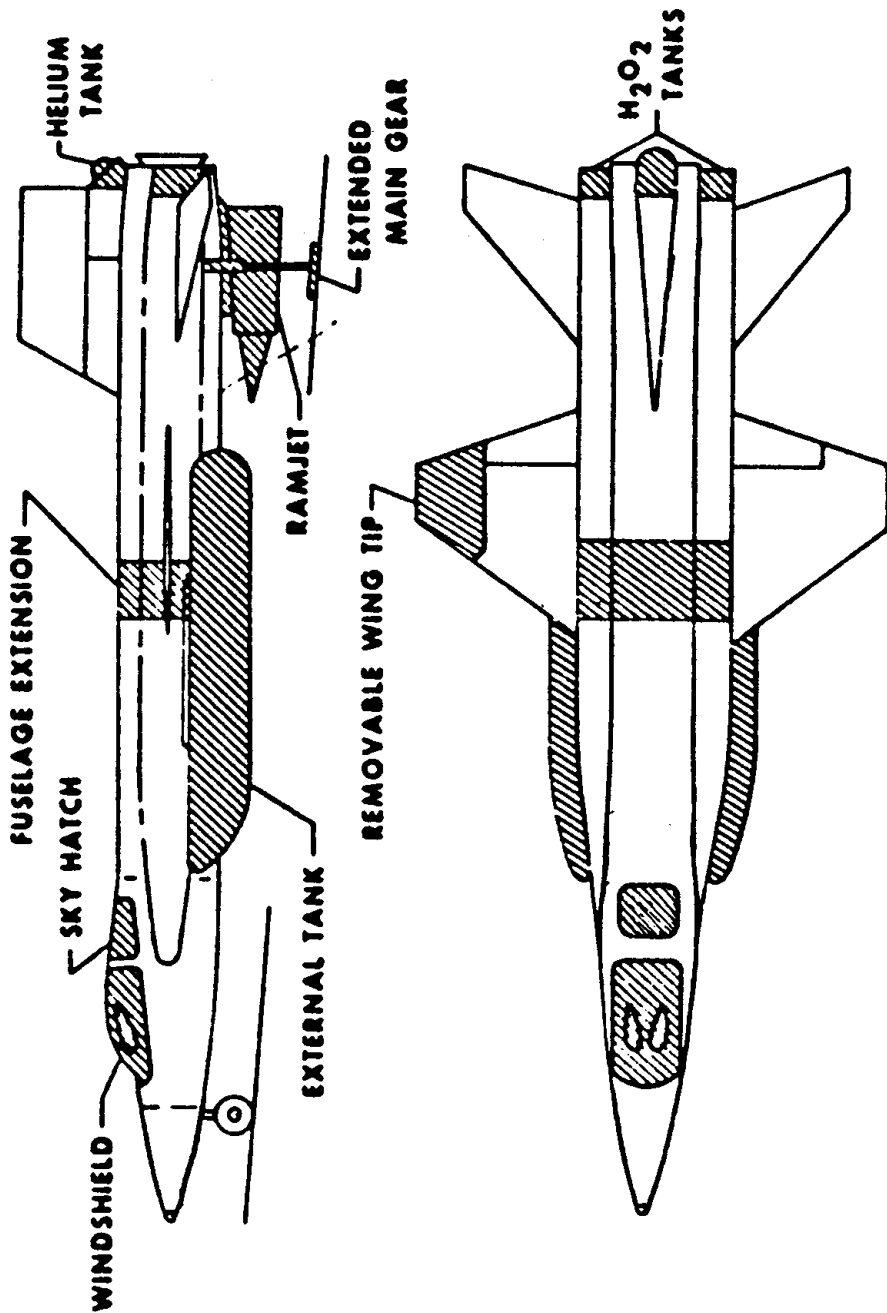


Following awarding of the X-15 development contract, North American had considered a so-called "X-15B" orbital spacecraft (even before Sputnik), to be launched by two Navaho boosters and possibly carry a two-astronaut crew. After Sputnik, it went through a cycle of shelving and revival until finally overcome by the ballistic blunt-body spacecraft approach as taken by the McDonnell Mercury vehicle. The X-15 series itself, however, did perform a number of "Shuttle" like missions, for after 1962, the X-15 program switched concentration from hypersonic aerodynamics to using the vehicle as a testbed carrying a wide range of applications and experiments, such as insulation intended for the Saturn booster, and navigation instruments under development for Apollo. By 1964, fully 65 percent of all data returned from the X-15 related to follow-on programs, and this figure continued rising until the conclusion of the program in December 1968. NASA even briefly considered using the X-15 as a launcher for Scout rockets carrying small satellite payloads, the B-52/X-15/Scout becoming, in effect, one large booster, but after examining the idea, NASA rejected it on grounds of safety, cost, and practicality. Fittingly, in December 1968, the Deutsche Gesellschaft für Raketentechnik und Raumfahrt awarded John Becker and the X-15 team with the Eugen Sänger Medal, created to honor individuals and groups who have made special contributions to the field of recoverable spacecraft.<sup>6</sup>

The following case study of the X-15 was prepared by the late Robert S. Houston of the then-Historical Branch, Office of Information Services, Wright Air Development Center, Wright-Patterson AFB, Ohio, in 1959. It has been expanded and updated by the editor to treat the X-15's flight test program and research legacy as well, with much of this supplementary material drawing upon the editor's On the Frontier: Flight Research at Dryden, 1946-1981 (Washington, D.C.: NASA, 1984), and then-Captain Ronald G. Boston's "Outline of the X-15's Contributions to Aerospace Technology", prepared in support of the National Hypersonic Flight Research Facility effort in 1977. At the time, Captain Boston was an instructor in the Department of History, Air Force Academy, Colorado Springs, Colorado.



Figure 3



THE MODIFIED X-15A-2 ROCKET RESEARCH AIRCRAFT

## NOTES

1. For general history of such studies in this time period, see NASA Langley Research Center staff report, "Conception and Research Background of the X-15 Project" (Hampton, VA: NASA LRC, June 1962), and NASA Langley Research Center staff report (draft document) "History of NACA-Proposed High-Mach Number, High-Altitude Research Airplane," (Hampton, VA: NASA LRC, n.d.), the latter hereafter referred to as NACA X-15 Origins, pp. 2-3. Both of these are in the files of the NASA History Office, Washington, D.C. Woods' proposals are in the meeting minutes of the NACA Committee on Aerodynamics, Oct. 4, 1951, Jan. 30, 1952, and June 24, 1952, in Record Group 255, National Archives, Washington, D.C. Hubert M. Drake and L. Robert Carman's "A Suggestion of Means for Flight Research at Hypersonic Velocities and High Altitudes" (Edwards, CA: NACA High-Speed Flight Research Station, n.d.), and "Suggested Program for High-Speed, High-Altitude Flight Research," (Edwards, CA: NACA HSFRRS, August 1953), are in the NASA History Office archives, Washington, D.C. For SAB interest, see Thomas A. Sturm, The USAF Scientific Advisory Board: Its First Twenty Years, 1944-1964 (Washington, D.C.: USAF Historical Division Liaison Office, Feb. 1, 1967), p. 59; The ONR-Douglas project is detailed in Douglas Aircraft Company Summary Report for Contract Nonr 1266(00), "High Altitude and High-Speed Study," (El Segundo, CA: DAC, May 28, 1954), in the corporate files of the McDonnell-Douglas Corporation, Douglas Aircraft division, Long Beach, California. I also wish to acknowledge the assistance of Douglas engineer Edward H. Heinemann's letter to me of Feb. 10, 1972. See also John V. Becker, "The X-15 Project," Astronautics & Aeronautics (February 1964), pp. 52-61. A good general summary of the X-15's development, including some excellent drawings of the various proposals of Bell, Douglas, Republic, and North American, can be found in Ben Guenther, Jay Miller, and Terry Panopolis, North American X-15/X-15A-2, Aerofax Datagraph 2 (Arlington, TX: Aerofax, Inc., 1985), pp. 1-8.
2. NACA Research Airplane Projects Panel meeting minutes, Feb. 4-5, 1954, from the files of the NASA Langley Research Center; NACA X-15 Origins, pp. 4-45; Interview with John V. Becker, NASA Langley Research Center, Nov. 12, 1971; Hallion, "American Rocket Aircraft;" Robert S. Houston, Development of the X-15 Research Aircraft, 1954-1959, v. III of History of Wright Air Development Center, 1958 (Dayton, OH: Wright-Patterson AFB, Office of Information Services, June 1959), pp. 3-13; 17-21; 82-127; 184-185.
3. John V. Becker, "Principal Technology Contributions of X-15 Program," (NASA Langley Research Center, Oct. 8, 1968); Becker, "The X-15 Program in Retrospect."
4. An excellent summation of early X-15 research can be found in Wendell H. Stillwell's X-15 Research Results, NASA SP-60 (Washington, D.C.: NASA, 1965), and Joseph Weil's NASA Technical Note D-1278, Review of the X-15 Program (Washington, D.C.: NASA, June 1962). See also James E. Love, "X-15: Past and Future," paper

presented at the Fort Wayne Section, Society of Automotive Engineers, Dec. 9, 1964; and Walter C. Williams, "The Role of the Pilot in the Mercury and X-15 Flights," Proceedings of the XIVth AGARD General Assembly, NATO, Sept. 16-17, 1964, Lisbon, Portugal.

5. Richard P. Hallion, "X-15: Highest and Fastest of Them All," Flight International (Dec. 23, 1978), pp. 2256-2257, 2258, 2262. The X-15A-2 program is discussed in detail in Johnny G. Armstrong's Flight Planning and Conduct of the X-15A-2 Envelope Expansion Program, AFFTC-TD-69-4 (Edwards AFB: Air Force Flight Test Center, 1969), passim.

6. Becker, "X-15 Program in Retrospect;" Sanger-Bredt, "Silver Bird," pp. 223-224.



## CHAPTER I

### GENESIS OF A RESEARCH AIRPLANE

During the spring of 1952, the Committee on Aerodynamics of the National Advisory Committee for Aeronautics (NACA) recommended that several NACA laboratories begin studies of problems likely to be encountered in spaceflight and examine methods of exploring such problems. The NACA Executive Committee, which endorsed the recommendation, directed consideration of laboratory techniques, missiles, and manned aircraft.

Work along these lines progressed quietly for the next two years. Then, in February 1954, the NACA stepped up the pace, undertaking a more specific study to determine the extent to which an advanced research aircraft could contribute to the solution of problems earlier identified. Technical areas of concern at that time included high temperature structures, hypersonic aerodynamics, stability and control, and pilotage. An important requirement, specified at the outset of the work, was that "a period of only about three years be allowed for design and construction in order to provide the maximum possible lead time for application of the research results." Such a requirement precluded the development of new materials, new construction techniques, or improved launching practices. As one official subsequently observed, "it was obviously impossible that the proposed aircraft be in any sense an optimum hypersonic configuration."

NACA design engineers decided early that a relatively conventional airframe was essential to the resolution of low speed launch and landing difficulties. High speed requirements prompted the choice of a thick wedge tail to provide directional stability

and a ventral tail to improve control at high angles of attack (where the upper vertical tail surface was immersed in low pressure flow fields generated by the wing and fuselage). Artificial damping seemed essential because of persistent uncertainties about the aerodynamic environment at extreme speeds and altitudes. Static stability for all flight conditions and the employment of hydrogen peroxide rockets for high altitude attitude control also became objectives of the tentative design. NACA materials experts decided that Inconel X offered the best heat sink structure and that heating problems in general would impose the use of a blunt wing leading edge. Assuming that air launch in the fashion of the X-1 and X-2 aircraft would be necessary, NACA established aircraft size as the largest that could conveniently be handled by B-36 or B-50 carriers. A maximum velocity of 6,800 feet per second, an altitude potential of 400,000 feet, and a gross weight of 30,000 pounds (18,000 pounds of fuel) completed the general proposal.<sup>1</sup>

The studies that had prompted these recommendations of early 1954 were independently produced by the three NACA laboratory stations (Langley, Ames, and High Speed Flight Station). They induced NACA to adopt the official policy that a manned research airplane was essential for study of the problems earlier defined, that the construction of such an aircraft was wholly feasible, and that quick action should be taken to pursue the general objective. In June of 1954, therefore, the NACA contacted the Air Force and the Navy, asking that a special joint meeting be held to consider the need for a new research aircraft.

Wright Air Development Center (WADC), then having cognizance over system development, provided technical representation for the Air Force at the meeting--held in Washington on July 9. Headquarters of the Air Research and Development Command (ARDC) and Headquarters, United States Air Force (USAF), sent policy representatives. In the course of the meeting it became apparent



that neither the Air Force nor the Navy had been indifferent to the problems which had prompted NACA interest. The Air Force's Scientific Advisory Board had been urging the construction of a "super X-2" while the Navy's Bureau of Aeronautics had contracted for a feasibility study of a manned aircraft capable of reaching an altitude of 1,000,000 feet. The NACA proposal fell roughly between these extremes, being considerably less ambitious than the Navy program and substantially more advanced than the Air Force objective of the moment.<sup>2</sup>

Both Navy and Air Force representatives viewed the NACA proposal with favor, though each had some reservations. At the close of the meeting, however, there was agreement that both services would study further the justification and objectives of the NACA program, and that NACA would take the initiative in securing project approval from the Department of Defense.<sup>3</sup>

Three weeks later, on July 29, Headquarters ARDC instructed WADC to submit technical comments on the proposal and to make time and cost estimates.<sup>4</sup> Almost immediately, the WADC Power Plant Laboratory identified the principal shortcoming of the original "study"--the apparent lack of a suitable rocket engine. Initially and tentatively, NACA had suggested employing a modified Hermes A-1 power plant; the Power Plant Laboratory early in August pointed out that "no current rocket engines" entirely satisfied the NACA requirements, and urgently emphasized that the Hermes engine was not designed to be operated in close proximity to humans--that it usually was fired only when shielded by concrete walls. Other major objections to the Hermes engine lay in its relatively low level of development, in its limited design life (intended for missile use, it was not required to operate successfully more than once), and in the apparent difficulty of incorporating thrust variation provisions.

In the stead of the Hermes power plant, the laboratory suggested consideration of several engines originally designed for use in manned aircraft. Hesitating to make any positive recommendations in the absence of more specific data on the aircraft, however, WADC recommended only that the selection of an engine be postponed until propulsion requirements could be more adequately defined.<sup>5</sup> WADC technical personnel who visited Langley on August 9 drew a firm distinction between engines intended for piloted aircraft and those designed for missiles; NACA immediately recognized the problem, but concluded that although program costs would go up, feasibility estimates would not be affected.<sup>6</sup>

WADC's official reaction to the NACA proposal went to headquarters ARDC on August 13.\* The director of laboratories (Colonel V. R. Haugen) reported "unanimous" agreement among WADC participants that the proposal was technically feasible; excepting the engine situation, there was no occasion for adverse comment from WADC technical sources on the NACA-proposed solutions to major problems.

In one respect, however, the official letter from WADC to ARDC did not reflect unanimity of opinion. The comment forwarded by Colonel Haugen contained a cost estimate of \$12,000,000 "distributed over three to four fiscal years" for two research aircraft, modification of a suitable carrier, and necessary government-furnished equipment.<sup>7</sup> Mr. R. L. Schulz, technical director for aircraft in the WADC Directorate of Weapon Systems Operations, commented informally that although his directorate had concurred in the letter, the concurrence included a reservation about the estimated cost which the Fighter Aircraft Division reportedly furnished. Said Mr. Schulz, prophetically: "Remember the X-3, the

---

\* A published summary of the July 9 NACA presentations did not appear until August 14.

X-5, [and] the X-2 overran 200%. This project won't get started for \$12,000,000."<sup>8</sup>

On September 13, Major General F. B. Wood, ARDC's Deputy Commander for Technical Operations, forwarded to Air Force headquarters an endorsement of the NACA position and its WADC support. Specifically, General Wood recommended that the Air Force "initiate a project to design, construct, and operate a new research aircraft similar to that suggested by NACA without delay." The aircraft, emphasized ARDC, should be considered a pure research vehicle and should not be programmed as a weapon system prototype. The research command estimated that about three and one-half years would be consumed in the design and fabrication process and forwarded WADC's cost estimate, broken down into specifics, without change. (Estimated costs included: \$1,500,000 for design work; \$9,500,000 for construction and development, including flight test demonstration; \$650,000 for government furnished equipment, including engines, \$300,000 for design studies and specifications; and \$250,000 for modification of a carrier aircraft.) ARDC further suggested a preliminary design competition, assignment of "sole executive responsibility" to the Air Force, and eventual transfer of the resulting aircraft to NACA following a limited Air Force flight demonstration program.<sup>9</sup>

Brigadier General B. S. Kelsey, Deputy Director of Research and Development in the office of the USAF Deputy Chief of Staff, Development, on October 4, 1954 expressed general agreement with the ARDC position, noting however that the Department of Defense had decided that the project would be a joint Navy-NACA-USAF effort managed by the Air Force and guided by a joint steering committee. A 1-B priority, \$300,000 in fiscal year 1955 funds, and directions to support the undertaking accompanied this explanation. Air Force headquarters further pointed out the necessity for funding a special flight test range as part of the project.<sup>10</sup>

Formalization of the arrangements thus proposed required nearly eight weeks. On October 5, the NACA Committee on Aerodynamics formally endorsed the proposal to build a Mach 7 research airplane to explore the fringes of space.<sup>11</sup> On October 22 a meeting of Navy, NACA, and Air Force representatives at Wright Field agreed on methods of originating and coordinating design requirements for an eventual competition. Additionally, the conferees settled on four development engines from which a power plant could be chosen by any interested airframe contractor.<sup>12</sup> Early in November the two services and NACA reached a general agreement on future operating procedures; a formal memorandum of understanding emerged from the office of Mr. Trevor Gardner (Special Assistant for Research and Development to the Secretary of the Air Force), and was forwarded for the signatures of the Assistant Secretary of the Navy for Air (Mr. J. H. Smith Jr.) and the Director of the NACA (Dr. H. L. Dryden). The process was effectively complete by December 23.<sup>13</sup>

The memorandum of understanding, which set a general pattern for the future management of the project, assigned technical direction of the program to the director, NACA, "with the advice and assistance of a 'Research Airplane Committee'" that included Navy and Air Force representatives. (General Kelsey became the Air Force member and Rear Admiral R. S. Hatcher the Navy member.) The Navy and the Air Force were to finance the undertaking and the Air Force was to administer its design and construction phases. The preliminary NACA design was to be the basis for solicited proposals for a design and construction contract. Upon acceptance of the airplane from the contractor, it was to become NACA property. The memorandum concluded with the statement: "Accomplishment of this project is a matter of national urgency."<sup>14</sup> Accompanying the memorandum, as a matter of course, was a secretarial-level Air Force concurrence in the establishment of a joint project to build the proposed research airplane.<sup>15</sup>

In the meantime, notwithstanding the absence of formal agreements or procedure, Wright Field had been making arrangements for a design competition. By November 15, individual laboratories had compiled specification data for inclusion in a letter of invitation to prospective contractors. Coordination with NACA and Navy organizations presented no great difficulty; by November 30 headquarters ARDC had approved plans to prepare official copies of competition data and had advised Wright Field that in about two weeks the Office of the Secretary of Defense probably would authorize distribution of the material.<sup>16</sup> Air Force headquarters scheduled a December 13 briefing for the Secretary of Defense and approved certain changes in the draft requirements. (USAF specified that air-launch was required, that a prone-pilot provision would not be acceptable, that unconventional design approaches would be sought, that instrumentation space was to be increased, that non-NACA facilities would be used for flight tests, and that references to costs in excess of \$5,000,000 and to 1956 engine availability were to be eliminated from the invitation to bid.)<sup>17</sup>

Advance notice of the forthcoming competition was informally given to prospective contractors early in December. In the last week of December, headquarters ARDC directed that the letter of invitation be dispatched as soon as the center received an official teletype authorizing such action. As prescribed by existing regulations, the letter was to be circulated by the Air Materiel Command (AMC), although that organization declined responsibility for selecting the recipients and held to the policy that the competition was exclusively an ARDC affair.<sup>18</sup>

On December 29 the action teletype from Air Force headquarters arrived.<sup>19</sup> Rubber stamp dates completed the preparation process, and on December 30 AMC, over the signature of Colonel C. F. Damberg, Chief, Aircraft Division, sent invitation-to-bid letters to 12 prospective contractors (Bell, Boeing, Chance-Vought, Convair,

Douglas, Grumman, Lockheed, Martin, McDonnell, North American, Northrop, and Republic). The document asked that interested concerns notify Wright Field by January 10, 1955 and plan to attend a special briefing on January 18.

Attached to the letter were a general preliminary outline specification, an abstract of the NACA preliminary study, a discussion of power plant requirements and development levels, a list of data requirements, and a cost outline statement. Each bidder was required to satisfy various requirements thus set forth, except in the case of the NACA abstract which was presented as "representative of possible solutions."<sup>20</sup>

Grumman, Lockheed, and Martin expressed slight interest in the competition and did not appear at the January 18 briefing. Subsequently, between that date and the May 9 deadline for the submission of proposals, Boeing, Chance-Vought, Convair, Grumman, McDonnell, and Northrop informed AMC that they would not participate. This left Bell, Douglas, North American and Republic as competitors.

Activity in the interim was varied. The contractors concentrated on the assembly of attractive proposals. In the course of this effort they had frequent recourse to the advisory services of both WADC and NACA. Concurrently, project officers (in the New Developments Office, Fighter Aircraft Division, Directorate of Weapon Systems Operations, which had been assigned full responsibility for the balance of the competition) attempted to refine an evaluation procedure acceptable to all concerned and sent supplemental data to the participating contractors. Of these tasks, the evaluation procedure loomed larger. Headquarters ARDC in early February emphasized the extreme importance of resolving all possible differences of opinion on the conduct of the technical evaluation; to this end, ARDC instructed that the ultimate recommendation

reflect the opinion of NACA as well as that of WADC. Plans had been laid for submitting the evaluation rules to the Joint Steering Committee for approval.<sup>21</sup>

Supplemental instructions to contractors reemphasized the urgency of the two and one-half year development period of the X-15.\* The project office also relaxed very slightly the rigid limitations on engine selection, instructing competitors that "if . . . an engine not on the approved list offers sufficient advantage, the airframe company may, together with the engine manufacturer, present justification for approval to the WSPO (Weapon System Project Office)."<sup>22</sup>

The Power Plant Laboratory had originally listed the XLR81 and the XLR73, the XLR10 (and its variants--a compound XLR10 and a modification of the XLR30), and the NA-5400 (a North American engine in early development, still lacking a military designation) as engines that airframe competitors could use in their designs. Early in January, the laboratory had become concerned that the builders of engines other than those listed might protest the exclusion of their products. Consequently there emerged from the Liquid Rocket Section of the laboratory an explanation and justification of the engine selection process. It appeared that the engineers had confidence in the ability of the XLR81 and XLR73 to meet airplane requirements, had doubts about the suitability of the XLR25 (a Curtiss-Wright product), and held the thrust potential of the XLR8 and XLR11 (similar engines) in low repute. This for practical purposes exhausted the fund of Air Force-developed engines suitable for manned aircraft. Navy consultants had introduced the other two engines defined as acceptable in terms of the competition.<sup>23</sup>

---

\* By early February, the designation X-15 had been assigned to the proposed research aircraft, although in unclassified references it still carried the original title, "Project 1226."

At about the time the industry briefing was held, the project office began seriously to consider sending copies of the bid invitation to "appropriate engine contractors." The Power Plant Laboratory discouraged unlimited distribution because of the possible compromise of proprietary data, but suggested that limited information be circulated and that inquiring contractors be informed what the Air Force had said about their own engines.<sup>24</sup> A course similar to this eventually was adopted; on February 4 each of the prospective engine contractors earlier identified (Reaction Motors, General Electric, North American, and Aerojet) was asked to submit a suitable engine development proposal.<sup>25</sup> Even earlier, certain of the engine contractors had been contacted for specific information about the engines originally listed as suitable for the X-15 program.<sup>26</sup> This information, relating to design and performance details, was distributed to all four prospective airframe contractors.<sup>27</sup> Data on the North American NA-5400 was scant, and the Reaction Motors XLR10 received a "not recommended" classification (at the suggestion of the engine contractor himself).

Progress in the completion of evaluation arrangements was less rapid than had originally been anticipated. A March 1 deadline established by ARDC early in February was later extended to April 1, and the material itself did not leave Wright Field until April 11.<sup>28</sup> Nevertheless, by that time the evaluation rules had been fully coordinated within WADC and with NACA.

The burden of the evaluation process fell on the project office, the WADC laboratories, and NACA--in that order. AMC and the Navy were to play subordinate--though still significant--roles. Four evaluation areas were specified: performance, technical design, development capability, and cost.<sup>29</sup>

Headquarters ARDC forwarded the WADC evaluation plan to Air Force headquarters for approval and then advised WADC that the



Research Airplane Committee planned to meet at Wright Field on May 17 to examine the submitted designs and to review evaluation arrangements. ARDC also suggested that commitments be obtained from the various engine contractors as early as possible so that the engine program would not adversely affect the selection of a winning airframe design.<sup>30</sup>

On the appointed day, May 9, 1955, Bell, Douglas, North American, and Republic submitted their proposals to the project office. Two days later the technical data went to the several laboratories with a request that evaluation results be reported by June 22. On May 17 the bidders made separate presentations to the Research Aircraft Committee and to a group of senior officials from WADC, ARDC, headquarters USAF, NACA, and the Air Force Flight Test Center. Later that day the Research Aircraft Committee confirmed previous arrangements for the evaluation procedure. Subsequently, both the Bureau of Aeronautics (Navy) and NACA independently accepted the resultant evaluation plan. Bureau of Aeronautics took pains to insure that Navy and NACA consultants participated in the joint evaluation.<sup>31</sup> Later arrangements insured that engine evaluations, also coordinated with the Navy and the NACA, would be available by July 12.<sup>32</sup>

The final evaluation meeting, to consider the results of earlier examinations and comments, was scheduled for Wright Field on July 25. In the interim, there was established a free interchange of preliminary opinion between Bureau of Aeronautics, NACA, and WADC laboratory and project office elements.<sup>33</sup> Notwithstanding this advance coordination, the evaluation results were delayed, first by the interference of higher priority work at WADC, later by a need for formal coordination with Bureau of Aeronautics.<sup>34</sup>

By August 5, the various portions of the evaluation had been completed and the evaluation report had identified North American's

proposal as having considerably greater merit than any of the others.\* On August 12 the Research Aircraft Committee accepted the findings. Preliminary moves to confirm this decision and to award a design contract to North American hit a sudden snag, however, when on August 23 North American's local representative verbally notified the Fighter Aircraft Division that the firm was withdrawing its proposal because of the press of other work.<sup>35</sup> The immediate reaction of Wright Field was to inform everybody concerned that the evaluation results would have to be reexamined. (No contractors had yet been notified of the outcome.) On August 30, the contractor officially and in writing confirmed his earlier announcement, citing inability to perform the work in the time allotted and recent awards in interceptor and fighter-bomber competitions plus a heavy F-107A workload as the motives. Within a week the project office (and the directorate) had decided that North American should be asked to reconsider the decision. But there was agreement that if the company held firm, Douglas would probably be ruled the competition winner, although the Douglas design (which employed magnesium instead of Inconel X) would require considerable modification before it satisfied NACA and USAF requirements.<sup>36</sup>

During the middle weeks of September, both NACA and Air Force officials discussed with North American possible continuance of the contractor's X-15 activity. Dr. Dryden of NACA and Brigadier General H. M. Estes of the newly formed Directorate of Systems Management\*\* had prominent roles in these negotiations. A presentation of the X-15 program at the Department of Defense level, on September 14, induced a recommendation that the program be approved. Concurrently, however, two changes in philosophy appeared. First, the Army representative at the conference said

---

\*The final evaluation ranked North American first, with Douglas, Bell, and Republic following in order of merit.

\*\* In August, the WADC Directorate of Weapon Systems Operations was transferred to the jurisdiction of headquarters ARDC and was given a new title.

flatly that the Army would oppose the project if it required special Department of Defense funds. This stand prompted an attempt to reduce program costs below earlier estimates. At the same time, it began to appear inevitable that the program would take more than the 30 months originally projected. On this basis, it seemed that North American might still be considered a competitor. The contractor's reluctance to proceed was frankly based on the thesis that the company could not devote sufficient effort to the X-15 project to permit its completion within the span of time initially provided.<sup>37</sup>

On September 20 and 21, contacts with Air Force headquarters confirmed earlier information that the Department of Defense had approved the project and North American's selection. But before any formal contract negotiations could be authorized, said the Department of Defense, a reduction in annual budget requirements would be necessary.

As these instructions reached Wright Field, General Estes was conferring with Mr. J. L. Atwood, North American's president. Mr. Atwood told the general that his company would reconsider its decision on the X-15 if the program were extended by eight months (to 38 months). Two days later, on September 23, this offer was made officially. North American emphasized, however, that a program extension was essential to the company's accepting a contract.<sup>38</sup>

On September 27, Air Force headquarters agreed to this condition and canceled earlier instructions to negotiate a reduction in the contractor's fee. Information on the decision reached the center on September 28; on the last day of that month, letters went to North American and to the unsuccessful bidders, officially advising them of the outcome of the competition.<sup>39</sup>

Price negotiations followed. Wright Field project officers took the results of preliminary contact with North American (and with

Reaction Motors, the prospective engine contractor) to a Pentagon meeting of October 11. By that time the contractor's estimate of project cost had been reduced from \$56,000,000 to \$45,000,000 and the maximum annual funds requirement from \$26,000,000 to \$15,000,000. The USAF Directorate of Research and Development made a presentation of these figures to the Department of Defense Coordinating Committee on Piloted Aircraft on October 19. The result was a committee decision to support the project. Shortly thereafter, the Department of Defense released the funds needed for the start of work. More meetings between NACA, project office, and North American personnel were held on October 27 and 28, largely to define changes to the aircraft configuration originally submitted by the contractor. On November 7, the AMC Directorate of Procurement and Production took the first steps toward issuance of a letter contract, by November 9 the principal clauses of that document had been composed, on November 15 it received the approval of the procurement directorate, on November 18 it was sent to North American, and on December 8 the contractor returned an executed copy.<sup>40</sup> At that point, about \$2,600,000 was available to fund initial activity; a total contract cost of \$39,000,000 was foreseen for design, development, three X-15 aircraft, and a flight demonstration program.<sup>41</sup>

On December 1, 1955, a series of actions designed to produce an engine contract began.<sup>42</sup> A letter contract with Reaction Motors became effective on February 14, 1956. Its initial allocation of funds totalled \$3,000,000, with an eventual expenditure of about \$6,000,000 foreseen as necessary for the delivery of the first flight engine.<sup>43</sup>

A definitive contract for North American was completed on June 11, 1956, superseding the letter contract and two intervening amendments. To that time, \$5,315,000 had been committed to North American, in three increments, under the letter contract.

(Essentially, North American had been given \$2,715,000 more than the initial allocations.) The definitive contract of June contemplated the eventual expenditure of \$40,263,709 plus a fee of \$2,617,075. For this sum, the government was to receive three X-15 research aircraft and other specified items: a high speed and a low speed wind tunnel model program, a free-spin model, a full-size mockup, propulsion system tests and stands, flight tests, modification of a B-36 carrier, a flight handbook, a maintenance handbook, technical data, periodic reports of several types, ground handling dollies, spare parts (\$100,000), and ground support equipment (\$200,000). Exclusive of contract costs were fuel and oil, special test site facilities, and expenses incident to operation of a B-36 carrier. Delivery date for the aircraft and support equipment was to be October 31, 1958.<sup>44</sup>

A final contract for the engine, the prime unit of government furnished equipment, was effective on September 7, 1956. Superseding the letter contract of February, it covered the expenditure of \$10,160,030 plus a fee of \$614,000.\* For this sum, Reaction Motors agreed to deliver one engine, a mockup, reports, drawings, and tools. The engine described in the final contract was to have a maximum thrust of 50,000 pounds, to include provisions allowing for inflight thrust variation between 30 to 100 percent of maximum output, to be capable of 90 seconds operation at full thrust and 4 minutes 9 seconds at 30 percent thrust, to weigh 618 pounds (without fuel), and to have a specific impulse of 241 (pounds of thrust per pound of fuel per second).<sup>45</sup>

---

\*The fee to Reaction Motors was greater than the original funds estimate for the total engine program; the definitive contract proposed expenditure of 20 times as much as the original estimate and twice as much as the original program approval. As events later demonstrated, even this erred badly on the side of underestimation.

## NOTES

1. Res. Airplane Comm., Report on Conference on the Progress of the X-15 Project, compilation of the papers presented at the Langley Aero. Lab., 25-26 Oct. 1956, pub. by NACA-Langley, in files of X-15 WSPO, pp. xvii-xix and pp 3-9 (hereafter cited as Report on Progress of the X-15-1956).
2. Ibid; TT, RDTDP-6-15-E, Cmdr., ARDC, to Cmdr., WADC, 17 June 1954; TT, RDTDP-6-22-E, Cmdr., ARDC, to Cmdr., WADC, 21 June 1954.
3. Memo., J. W. Rogers, Liquid Propellant and Rocket Br., Rocket Propulsion Div., to Lt. Col. L. B. Zambon, Power Plant Lab., WADC, 13 July 1954.
4. Ltr., Col. P. F. Nay, Actg. Ch., Aero. and Propulsion Div., Dep. Cmdr/Tech. Ops., ARDC, to Cmdr., WADC, 29 July 1954, subj.: New Research Aircraft.
5. DF, E. C. Phillips, Ch., Ops. Office, Power Plant Lab., to Dir/Labs., WADC, 5 Aug. 1954, subj.: NACA Conference on 9 July 1954 on Research Aircraft-Propulsion System; ltr., Col. V. R. Haugen, Dir/Labs., WADC, to Cmdr., ARDC, 13 Aug. 1954, subj.: New Research Aircraft.
6. Memo., J. W. Rogers, Liquid Propellant and Rocket Br., Rocket Propulsion Div., Power Plant Lab., to Ch., Non-Rotating Engine Br., Power Plant Lab., WADC, 11 Aug. 1954, subj.: Conferences on 9 and 10 August 1954 on NACA Research Aircraft-Propulsion System.
7. Ltr., Haugen to Cmdr., ARDC, 13 Aug. 1954.
8. Memo., R. L. Schulz, Tech. Dir/Ac., to Ch., Ftr. Ac. Div., Dir/WSO, WADC, about 13 Aug. 1954.
9. Ltr., Maj. Gen. F. B. Wood, Dep. Cmdr/Tech. Ops., ARDC, to Dir/R&D, USAF, 20 Sept. 1954, subj.: New Research Aircraft.
10. Ltr. (1st Ind.), Brig. Gen. B. S. Kelsey, Dep. Dir/R&D, DCS/D, USAF, to Cmdr., ARDC, 4 Oct. 1954, subj.: New Research Aircraft.
11. DF, Col. D. D. McKee, Ch., Ac. Lab., to Dir/Labs., WADC, 18 Oct. 1954, subj.: Trip Report.
12. DF, T. J. Keating, Ch., Non-Rotating Engine Br., Power Plant Lab., to J. B. Trenholm, Ch., New Dev. Office, Ftr. Ac. Div., Dir/WSO, WADC, 15 Nov. 1954, subj.: New NACA Research Aircraft; memo., J. W. Rogers, Liquid Propellant and Rocket Br., Rocket Propulsion Div., to Ch., Power Plant Lab., WADC, 4 Jan. 1955, subj.: Selection of Engines for New Research Airplane.

13. Memo., T. Gardner, Special Asst/R&D, USAF, to Asst. Secy. Navy/Air, 9 Nov. 1954, subj.: Principles for the Conduct of a Joint Project for a New High Speed Research Airplane; ltr., J. H. Smith Jr., Asst. Secy. Navy/Air, to Dir/NACA, 21 Dec. 1954, no subj.; Report on Progress of the X-15-1956.
14. Memo. of Understanding, signed by H. L. Dryden, Dir/NACA, J. H. Smith Jr., Asst. Secy. Navy/Air, and T. Gardner, Special Asst/R&D, USAF, 23 Dec. 1954, subj.: Principles for the Conduct by the NACA, Navy, and Air Force of a Joint Project for a New High-Speed Research Airplane.
15. Memo., Gardner to Asst. Secy. Navy/Air, 9 Nov. 1954.
16. Ltr., Col. P. F. Nay, Ch., Aero. and Propulsion Div., Dep. Cmdr/Tech. Dev., ARDC, to Cmdr., WADC, approx. 30 Nov. 1954, subj.: Competition for New Research Aircraft.
17. TT, AFDRD-AN-43671, C/S, USAF, to Cmdr., ARDC, 8 Dec. 1954.
18. Memo., A. L. Sea, Asst. Ch., Ftr. Ac. Div., to Dir/WSO, WADC, 29 Dec. 1954, subj.: New Research Aircraft.
19. Ibid.
20. Ltr., Col. C. F. Damberg, Ch., Ac. Div., AMC, to Bell Ac. Corp. (hereafter cited as Bell), et. al., 30 Dec. 1954, subj.: Competition for New Research Aircraft; memo., Sea, to Dir/WSO, WADC, 29 Dec. 1954; ltr., J. B. Trenholm, Ch., New Dev. Office, Ftr. Ac. Div., Dir/WSO, WADC, to Cmdr., ARDC, 13 Jan. 1955, subj.: New Research Aircraft.
21. Ltr., Brig. Gen. D. R. Ostrander, Dir/Dev., Dep. Cmdr/Tech. Ops., ARDC, to Cmdr., WADC, 2 Feb. 1955, subj.: X-15 Special Research Airplane.
22. Ltr., Col. C. F. Damberg, Ch., Ac. Div., AMC, to Bell, et. al., 2 Feb. 1955, subj.: Project 1226 Competition.
23. Memo., Rogers to Ch., Power Plant Lab., 4 Jan. 1955.
24. DF, T. J. Keating, Ch., Non-Rotating Engine Br., Power Plant Lab., to Lt. C. E. McCollough Jr., New Dev. Office, Dir/WSO, WADC, 14 Jan. 1955, subj.: Project 1226 -Information for Engine Contractors.
25. Ltr., R. W. Walker, Ch., Power Plant Dev. Sect., Power Plant Br., Aero. Equip. Div., AMC, to Reaction Motors, Inc. (hereafter cited as RMI), 4 Feb. 1955, subj.: Power Plant for New Research Airplane.

26. Ltr., W. P. Turner, Mgr., Customer Relations and Contr. Div., RMI, to Cmdr., AMC, 3 Feb. 1955, subj.: XLR30 Rocket Engine-Information Concerning.
27. Ltr., J. B. Trenholm, Ch., New Dev. Office, Ftr. Ac. Div., Dir/WSO, WADC, to Bell, et. al., 22 Mar. 1955, subj.: Transmittal of Data, Project 1226 Competition.
28. Ltr., Ostrander to Cmdr., WADC, 2 Feb. 1955; ltr., Brig. Gen. H. M. Estes Jr., Dir/WSO, WADC, to Cmdr., ARDC, 11 Apr. 1955, subj.: X-15 Research Aircraft.
29. Ltr., Estes to Cmdr., ARDC, 11 Apr. 1955.
30. Ltr., Col. P. F. Nay, Ch., Aero. and Propulsion Div., Dep. Cmdr/Tech. Ops., ARDC, to Cmdr., WADC, 26 Apr. 1955, subj.: X-15 Research Aircraft.
31. Ltr., H. L. Dryden, Dir/NACA, to Dep. Dir/R&D, DCS/D, USAF, 20 May 1955, no subj.; ltr., Rear Adm. R. S. Hatcher, Asst. Ch/R&D, BuAer, USN, to Cmdr., WADC, 31 May 1955, subj.: Agreements Reached by "Research Airplane Committee," on Evaluation Procedure for X-15 Research Airplane Proposals.
32. Suborder, J. B. Trenholm, Ch., New Dev. Office, Ftr. Ac. Div., Dir/WSO, to Ch., Rocket Sect., Non-Rotating Engine Br., Power Plant Lab., WADC, 20 June 1955, subj.: X-15 Research Aircraft.
33. Memo., Brig. Gen. H. M. Estes Jr., Dir/WSO, to Dir/Labs., WADC, 28 June 1955, subj.: X-15 Evaluation.
34. Ltr., J. B. Trenholm Jr., Ch., New Dev. Office, Ftr. Ac. Div., Dir/WSO, WADC, to Cmdr., ARDC, 1 July 1955, subj.: X-15 Research Aircraft Evaluation Schedule; comments, Capt. C. E. McCollough Jr., Ftr. Ac. Div., Dir/WSO, WADC, July 1955.
35. Memo., Col. C. G. Allen, Ch., Ftr. Ac. Div., Dir/Sys. Mgmt., ARDC, to Cmdr., WADC 23 Aug. 1955, subj.: X-15 Evaluation. DF, Col. C. G. Allen, Ch., Ftr. Ac. Div., to Ch., New Dev. Office, Ftr. Ac. Div., Dir/Sys. Mgmt., ARDC, 7 Sept. 1955, subj.: X-15 Evaluation.
36. DF, Allen to Ch., New Dev. Office, 7 Sept. 1955.
37. X-15 WSPO Weekly Activity Rpt. (hereafter cited as WAR), 22 Sept. 1955; interview, W. B. Underwood, NACA Liaison Officer, 1 Oct. 1955, by Robert L. Perry, Ch., Hist. Br., WADC.
38. TT, AFDRD-30259, C/S, USAF, to Cmdr. ARDC, 20 Sept. 1955; TT RDZ-1SFF-9-514-E, Dir/Sys. Mgmt. to Cmdr., ARDC, 23 Sept. 1955; ltr., R. H. Rice, Vice Pres. and Ch. Engr., North American Avn.,



Inc. (hereafter cited as NAA), to Cmdr., ARDC, 23 Sept. 1955, subj.: Project 1226, Research Airplane.

39. Ltr., Col. C. F. Damberg, Ch., Ac. Div., AMC, to NAA, 30 Sept. 1955, subj.: X-15 Competition.

40. X-15 WSPO WAR, 13 Oct. 1955; 20 Oct. 1955; 27 Oct. 1955; and 15 Dec. 1955; DF, Col. B. C. Downs, Ch., Ftr. Br., to Ch., Ac. Div., Dir/Proc. and Prod., AMC, 7 Nov. 1955, subj.: Request for Permission to Negotiate a CPFF Type Contract -P.R. No. 636317 and 198558; ltr., N. Shropshire, Dir/Contr. Admin., NAA, to Cmdr., AMC, 8 Dec. 1955, subj.: Letter Contract AF33(600)-31693.

41. DF, Downs to Ch., Ac. Div., 7 Nov. 1955.

42. DF, Capt. C. E. McCollough, Proj. Officer, New Dev. Office, Ftr. Ac. Div., Dir/Sys. Mgmt., ARDC, to Ch., Non-Rotating Engine Br., Power Plant Lab., Dir/Labs., WADC, 1 Dec. 1955, subj.: Engine for X-15.

43. Ltr. Contr. AF33(600)-32248, 14 Feb. 1956, in files of Contr., Dist. and Files Sect., AMC (hereafter cited as AMC contr. files); X-15 WSPO WAR, 13 Oct. 1955.

44. Contr. AF 33(600)-31693, 11 June 1956.

45. Contr. AF33(600)-32248, 7 Sept. 1956.



## CHAPTER II

### DESIGNING FOR MACH 6

Although the invitation-to-bid letter circulated to prospective contractors by the Air Materiel Command had specifically excluded the NACA Preliminary Study as a requirement, North American's winning proposal bore an unsurprising resemblance to the design envisioned by that study. A comparison of the suggested configuration contained in the NACA study and the North American configuration presented to the first industry conference in October 1956 revealed that the span of the X-15 had been reduced from the 27.4 feet of the suggested configuration to only 22 feet and that the North American fuselage had grown from the suggested 47.5 foot overall-length to 49 feet. The North American design contained the split tail surfaces, the wing and tail flaps, the leading-edge sweep for both wing and tail surfaces, and the skid-type landing gear which had been suggested by the preliminary study. The all-movable tail of the 1956 configuration still retained the thick wedge airfoil envisioned by NACA and the horizontal tail surfaces incorporated the cathedral (downward slope or negative dihedral) which had also been a feature of the NACA suggestions. The major differences in external configuration between the study proposal and the design which North American presented consisted of an elimination of ailerons and of separate stabilizers and elevators. North American eliminated the ailerons and elevators by utilizing all-movable horizontal tail surfaces that could be operated differentially so as to provide roll as well as pitch control (the "rolling tail"). North American had gained considerable experience with all-movable controls through using them on the F-107 fighter design, and in this instance use of the differentially operated surfaces permitted simplification of wing

construction and elimination of the protuberances that would have been necessary if aileron controls had been incorporated in the thin airfoil sections of the X-15's wings. Such protuberances would have disturbed the airflow and created another heating problem. One other significant difference between the configuration of the NACA design and that of the X-15 stemmed from North American's incorporation of the propellant tanks in the fuselage structure and the use of tunnels on both sides of the fuselage to accommodate the propellant lines and engine controls that ordinarily would have been contained within the fuselage. North American followed the NACA suggestions by selecting Inconel alloy as the major structural material and in the design of a multispar wing with extensive use of corrugated webs.<sup>1</sup>

The original North American proposal gave rise to several questions which in turn, on October 24 and 25, 1955, prompted a meeting attended by NACA and WADC personnel at Wright-Patterson Air Force Base. The purpose was to consider necessary changes in North American's preliminary design. The meeting formulated a list of questions and comments to serve as the basis of discussions with the contractor. Subsequent meetings of the WADC-NACA group with North American's engineers were held at the contractor's Inglewood plant on October 28 and 29 and November 14 and 15. The items considered at the October and November meetings included North American's use of fuselage tunnels and the rolling tail. The government agencies expressed concern that the tunnels might create undesirable vortices that would interfere with the vertical tail, and suggested that the tunnels be kept as short as possible in the area ahead of the wing. North American agreed to make the investigation of the tunnels' effects a subject of an early inquiry in the model testing program. The contractor also agreed that the

"rolling tail" should be proved or disproved as quickly as possible.\*

NACA computations indicated that the minimum design dynamic pressure should be 2,100 pounds per square foot and that 2,500 pounds per square foot would be desirable, while North American's design had proposed a design dynamic pressure of only 1,500 pounds per square foot. A structural weight increase of slightly over 100 pounds would enable the design to withstand the 2,500 pound pressure; conferees agreed that the weight increase was justified and that North American should alter the design to meet the 2,500 pound per square foot requirement. On the other hand, a government request that the design be altered to increase the design load factor from 5.25g to 7.33g at a 30-percent fuel-remaining condition involved a weight increase of another 135 pounds which the agencies and North American agreed might better be used to raise the design dynamic pressure. North American also agreed to raise the 35 feet per second negative gust velocity of the design to the 55 feet per second considered desirable by the government representatives.

In addition to the discussions on structural criteria, considerable attention was devoted to the proposed structural materials. At the time of the meeting, neither the WADC-NACA representatives nor the North American engineers seemed to have any detailed information that would permit a final decision on the materials to be used in such critical structures as the leading edge of the wing and the dive brakes. Such diverse materials as plastic, titanium carbide, copper, and cermets were considered for the leading edges; the only definite conclusion was that North American would investigate the relative advantages of several

---

\*Eventually, an Air Force-NACA study team journeyed to France to study the Sud-Ouest Trident interceptor, which had such a tail configuration.

proposed materials. It was agreed to retain the design features which would enable the leading edge to be easily detached and replaced. The NACA-WADC team pointed out that the assumption of laminar flow in heating calculations was unrealistic and North American agreed to build in accordance with the results obtained from calculations based on both laminar and turbulent flow. It was also agreed that .020-inch titanium alloy was a more desirable material for the internal structure of the wings and horizontal and vertical stabilizers than the 24ST aluminum that had been proposed, even though the use of titanium produced a weight increase of approximately seven pounds. Another weight increase of 13 pounds was approved in order to allow the substitution of an Inconel-X sandwich construction in place of the stainless steel dive brakes proposed by North American, and to allow for additional dive brake hinges. Other structural problems discussed included a change from titanium to Inconel-X for the oxygen tank because of the low-impact strength of titanium at low temperatures and the need to include a pressure system for stabilizing the propellant tanks. Pressurization of the propellant tanks had been considered undesirable and in the original design had not been provided. The decision to increase the design dynamic pressure from the original 1,500 to 2,500 pounds, together with North American's previous decision to utilize the tanks as structural components, made it necessary to accept pressurization or a large increase in structural weight. The decision was for pressurization of the tanks.

The WADC-NACA group and the North American engineers were in agreement that provision would have to be made for correcting any thrust misalignment and that further investigation would be needed to determine how such misalignment could be corrected and the amount of misalignment that would not be amenable to corrective shimming. The fact that the proposed design would probably be sensitive to roll-yaw coupling was also discussed and the acceptable limits were agreed upon.

In the area of control systems, the WADC-NACA group pointed out to the North American engineers that a rate damping system in pitch and yaw and possibly in roll would probably be necessary. North American estimated that the damping system would increase the weight of the design by approximately 125 pounds. A decision as to whether duplication of the damping system would be necessary was postponed until NACA's Ames Laboratory could be consulted. Conferees also decided that no damping system would be needed in the space control system. It was tentatively agreed that the pilot's controls should consist of a conventional center stick but that the aerodynamic controls should also be operable from a side-controller on the right console and that the space controls would be operated by a second side-controller on the left console. The space control system was the subject of further discussion that ended with North American's agreement to duplicate the entire system and to provide three and one-half times the hydrogen peroxide initially specified. The company also agreed to study the system with a view to minimizing fire hazards, shortening the peroxide lines, and relocating the peroxide supply nearer to the center of the airplane. Separate sources of peroxide would be provided for the reaction controls and the auxiliary power units. Engineers estimated that such changes in the reaction control system would result in a weight increase of about 117 pounds.

At the time of the meeting it was thought that WADC already had a satisfactory stable platform and it was agreed that this platform would be provided as government furnished equipment. NACA promised to provide a nose (then in the development stage) that would contain flight-path indication equipment.

Power-plant discussions were limited because the engine was still subject to extensive development and detailed information was nonexistent. The conference group decided, however, to increase the amount of helium provided for pressurization of the liquid

oxygen tank, to study the possible relocation of the helium supply to some area other than inside the oxygen tank, and to redesign the tank transfer tube inlets and the top-off system. Pressure systems were to be protected with relief valves and frangible disks or with duplicate relief valves. The number of engine restarts was to be raised from three to at least five, shut off valves were to be provided in the main propellant lines, and provision was to be made for selective jettisoning of the propellants. Peroxide tanks were to be compartmented and separated, particularly from the engine compartment; main propellant vents were also to be separated and located at the rear end of the jettison lines. Blow-off doors were to be put around the engine compartment and it was agreed to omit a thrust measuring system because of the additional complication such a system would entail.

Final decisions on the exact nature of the auxiliary power plants were delayed to permit further study but there was general agreement that two auxiliary power units should be provided and that they should include completely separate systems compartmented by fire walls.

The discussion between the government and company engineers covered several additional fields including ground check-out equipment, tankage, crew provisions, landing gear, ground equipment, the electrical system, and fire detection and extinguishing. With the exception of the crew provisions, these items were rather briefly considered and included such decisions as the use of nitrogen as the fire extinguishing agent both for ground and air use, the recalculation of the tankage requirements for liquid oxygen, the possibility of providing a jettisonable ventral fin, the various types of ground servicing equipment that would be necessary, the need for providing adequate electrical power for restarts, and making the electrical components explosion safe.



The discussions on crew provision were more detailed. North American agreed to design an ejection seat system and to make a study justifying the selection of a seat in preference to a capsule system. North American was also to provide suitable head and limb restraints for the accelerations to be encountered and to provide a means for external depressurization and canopy removal independent of the internal canopy jettison system. Transparent cockpit materials were to be studied (transparent plastics, like plexiglass were considered unsatisfactory) and deviations from standard cockpit dimensions were authorized. A gaseous oxygen system replaced the originally proposed liquid system and provisions were included for ram air ventilation below 20,000 feet. Nitrogen was to be used for cockpit pressurization.

The meetings came to a close with a presentation by Douglas engineers of some of the ideas contained in that company's X-15 design and a presentation by North American of its own rocket engine proposals for the X-15. The North American engine would have used oxygen and JP-4 or gasoline as the propellants. North American also presented the results of performance calculations based on the changes that had been discussed and determined upon at the meeting.<sup>2</sup>

By January of 1956, North American's design had progressed rapidly enough to require decisions on several questions that had not been discussed or on which no final decisions had been reached at the October-November meetings of the previous year. An NACA group visiting North American on January 18 was asked to provide additional information and guidance on a plan to use a removable instrument rack for the main instrument compartment. Some instruments were to be mounted permanently in the fuselage tunnels, but North American felt a removable rack would provide ready access to the instruments and allow the removal of the instruments during ground operations. This latter feature was considered desirable in

order to reduce the exposure of the instruments to ammonia fumes. North American also requested drawings of NACA research instruments and a statement as to which instruments would need to be shock mounted so that the company could complete its instrumentation plans. The company had also reached a stage in the design that required definite decisions on type and gauge of the wire to be used for thermocouples. North American also advised the NACA representatives of plans to use a modified ARC-48 radio communicator with four channels.

The subject of a stable platform\* came up and, contrary to the statements made at the October-November meetings of the previous year (that Wright Field had a stable platform and would furnish it to the X-15 project), the NACA group was advised that no decision had been made as to who would furnish the platform. The company asked for further information on instrument duty cycles because without such information, engineers were having difficulty in determining auxiliary power plant loads and heating and cooling requirements.

The NACA representatives agreed with a North American suggestion that the ammonia tank vents could be closed on the ground after filling, thus permitting the pressure to stabilize at the vapor pressure of ammonia. As this procedure prevented boil-off of ammonia, it eliminated the necessity for an ammonia top-off system.

Preliminary sketches of the aerodynamic side-controller were shown to the NACA group and as the sketches looked promising, plans

---

\*A gyroscopically stabilized mechanism that aligns itself to the local vertical to provide a reference plane that can be utilized for the derivation of altitude, attitude, velocity, and rate-of-climb information.

were made to have NACA's Langley Laboratory evaluate the system envisaged by North American.

Other topics discussed at this time included the design of the dive brakes and a landing study conducted by North American. Full extension of the dive brakes at pressures of 2,500 pounds per square foot would have created excessive longitudinal accelerations and the brakes were therefore designed to open only to a point where the pressure on them would be 1,500 pounds per square foot. The brakes would then open progressively, maintaining a constant pressure at the 1,500 pound level until the full open position was reached.<sup>3</sup>

During the spring and summer of 1956, several scale models were exposed to rather intensive wind tunnel tests. A 1/50-scale-model was tested in the 11-inch hypersonic and the 9-inch blowdown tunnels at Langley, and another in a North American tunnel. A 1/15-scale model was also tested at Langley and a rotary-derivative model was prepared for test at the Ames Laboratory. North American gave thought to a plan to mount a small model on the nose of a rocket in order to obtain heat-transfer data under flight conditions. Langley, not fully approving of North American's plans, undertook the study of possible alternatives. The various wind tunnel programs included investigations of the speed brakes, horizontal tails without dihedral, several possible locations for the horizontal tail, modifications of the vertical tail, the fuselage side fairings, and control effectiveness. Another subject in which there was considerable interest was that of determining the cross-section radii for the leading-edges of the various surfaces. A free-flight model tested at Langley indicated that the X-15 would have satisfactory handling characteristics. (The NACA studies confirmed the desirability of control system dampers, while during the same period, North American arrived at the conclusion that the airplane could be flown safely without them.)

At the conclusion of a meeting of NACA, WADC, Navy, and North American representatives held at WADC on May 2-3 for the purpose of settling upon specifications, the subject of escape was taken up once more. WADC personnel apparently were not convinced that the ejection seat previously decided upon was going to be adequate. They pointed out that Air Force policy required an enclosed system in all new airplanes and that a change to some form of capsule would not only be in accordance with this policy, but would provide research data on such escape systems. Those opposed to the WADC view objected to any change on the grounds that it would disrupt time schedules, increase weight, and that there was still considerable ignorance about capsule design. The group that opposed the change felt that the safety features of the X-15's structure made the ejection seat acceptable. As a result of this meeting, North American was asked to document the arguments justifying the use of the ejection seat.

A meeting, held at Langley on May 24 and attended by WADC personnel as well as NACA, North American, and Eclipse-Pioneer representatives, explored the possibilities for obtaining a suitable stable platform for the X-15. It appeared that such a platform could be ready in 24 months and that 40 pounds of the estimated total weight of 65 pounds could be charged to research instrumentation rather than to the aircraft itself.<sup>4</sup>

By June, NACA had completed the preliminary design for the spherical nose cone and had undertaken the construction of a heat-transfer model. They were in the process of preparing detailed specifications for the award of a contract for the cone and its drive mechanism.<sup>5</sup>

June was also the month in which formal assignment of Air Force serial numbers was made. The numbers were 56-6670 through 56-6672. Originally furnished by telephone on May 28, these numbers were

officially confirmed by the acting chief of the Contract Reporting and Bailment Branch on June 15.<sup>6</sup>

By July, NACA felt that sufficient progress had been made on the design problems presented by the X-15 to make an industry conference on the project worthwhile. Dr. Dryden, the director of NACA, invited WADC to participate in such a conference and asked that WADC review any material that might be suitable for presentation at the proposed conference. Dr. Dryden also asked that such material be summarized prior to August 8, as that date had been selected for a preliminary meeting of NACA, WADC, Navy, and North American representatives. The participants in the August meeting were to review the summarized material, decide whether the material was of sufficient interest to warrant an industry-wide meeting, and if the material did prove interesting, to make definite plans for a program to be conducted in October at one of the NACA's own facilities.<sup>7</sup>

The material did prove interesting and the proposed conference was held at Langley Field, Virginia, on October 25-26. Eighteen technical papers were presented to an audience of 313 individuals. Approximately ten percent of those attending the conference were representatives of various Air Force activities, and over half of these were WADC personnel. In view of the part which the Air Force had played in evaluating the original design and in the preliminary financing and procurement activities, it was surprising that there was absolutely no Air Force participation in the presentations. The majority of the twenty-seven authors who contributed papers were drawn from the NACA (16), while the remaining papers were authored by employees of the airframe (9) and engine (2) contractors.

It was evident from the papers presented at the industry conference that a considerable amount of valuable data had already

been gathered but that a number of areas still awaited exploration. The airframe design differed from that originally envisaged by NACA and departed significantly from the design originally submitted by North American. The major external difference was a result of the need for additional directional stability at high angles of attack. This increased stability was provided by the addition of a ventral tail. One of the papers summarized the aerodynamic characteristics that had been obtained by tests in eight different wind tunnel facilities.\* These tests had been made at Mach numbers ranging from less than 0.1 to about 6.9. The wind tunnel investigations were concerned with such problems as the effects of speed-brake deflection on drag, the lift-drag relationship of the entire aircraft, of individual components such as the wings and fairings, and of combinations of individual components. One of the interesting products was a finding that almost half of the total lift at high Mach numbers would be derived from the body-side fairing portion of the airplane. Another result was the confirmation of NACA's prediction that the original side fairings would cause longitudinal instability. (For subsequent testing the fairings had been shortened in the area ahead of the wing.) Still other wind tunnel tests had been conducted in an effort to establish the effect of the vertical and horizontal tail surfaces on longitudinal, directional, and lateral stability. Results of the wind tunnel tests were used to calculate the response characteristics of a configuration without dampers in order to determine if the aircraft would be flyable if the dampers should fail. Results indicated considerable instability and further investigations of alternate tail and rudder configurations were undertaken.

---

\*The facilities were those of the NACA's Langley and Ames laboratories, of North American, and of the Massachusetts Institute of Technology.

Other papers presented at the industry conference dealt with research into the effect of the aircraft's aerodynamic characteristics on the pilot's control. Pilot-controlled simulation flights for the exit and entry phases had been conducted; researchers reported that the pilots had found the early configurations unflyable without damping, and that even with dampers the airplane possessed only minimum stability for portions of the programmed flight plan. A program utilizing a free-flying model had proved low-speed stability and control to be adequate.

As some aerodynamicists had questioned North American's substitution of a differentially-operated horizontal tail for aileron control, the free-flying model had also been used to investigate that feature. The results indicated that such a tail provided the necessary lateral control.

Three of the papers presented at the conference dealt with aerodynamic heating. The first of these was a summary of the experience gained with the Bell X-1B and X-2 aircraft. The information was incomplete and not fully applicable to the X-15, but it did provide a basis for comparison with the results of the wind tunnel and analytical studies. The second paper contained information derived from wind-tunnel tests on various bodies similar to those employed in the X-15. The third paper dealt with the results of the structural temperature estimates that had been arrived at analytically. It was apparent from the contents of the papers on aerodynamic heating that the engineers compiling them were confronted by a paradox. In order to attain an adequate and reasonably safe research vehicle, they had to foresee and compensate for the very aerodynamic heating problems that were to be explored by the completed aircraft.

In addition to the papers on the theoretical aspects of aerodynamic heating, a report was made on the structural design

that had been accomplished at the time of the conference. The paper dealt with the wing, fuselage, and empennage. As critical loads would be encountered during the accelerations at launch weight and during reentry into the atmosphere, and as maximum temperatures would be encountered only during the second of these two phases, the paper was largely confined to the results of the investigations of the load-temperature relationships that were anticipated for the reentry phase. The selection of Inconel-X sheet as the covering for the multispar box-beam wing was justified on the basis of the strength and favorable creep characteristics of that material at 1200 degrees Fahrenheit. A milled bar of Inconel X was to be utilized for the leading edge, as it was intended that that portion of the wing act as a heat sink. The internal structure of the wing was to be of titanium-alloy sheet and extrusions. The front and rear spars were to be flat web channel sections with the intermediate spars and ribs of corrugated webs of the same material. For purposes of the tests the maximum temperature differences between the upper and lower wing surfaces had been estimated to be 400 degrees Fahrenheit and that between the skin and the center of the spar as 960 degrees. Laboratory tests indicated that such differences could be tolerated without any adverse effects on the structure. Other tests had proved that thermal stresses for the Inconel-titanium structure were less than those encountered in similar structures constructed entirely on Inconel. Full scale tests had been made to determine the effects of temperature on the buckling and ultimate strength of a box beam, the amount of the deformations at varying loads, temperatures and temperature differences, to ascertain creep effects due to repeated loads and heating, to evaluate structural attachments and the effect of large temperature differences on the bending stresses of the spars. Simply heating the test structure produced no surface buckles. Compression buckles had appeared when ultimate loads were applied at normal temperatures but the buckles disappeared with the removal of the load. Tests at higher temperatures and involving



large temperature differences had finally led to the failure of the test box, but it seemed safe to conclude that "thermal stresses had very little effect on the ultimate strength of the box."

Tests similar to those conducted on the wing structure had also been performed on the horizontal stabilizer. The planned stabilizer structure differed from the wing in that it incorporated a stainless steel spar about halfway between the leading and trailing edges, and an Inconel spar three and one-half inches from the leading edge. The remainder of the internal structure was to be similar to that of the wing in that it incorporated titanium components. The stabilizer skin was similar to that of the wing in being of Inconel-X sheet. Tests of the stabilizer had indicated that a design which would prevent all skin buckling would be inordinately heavy, so engineers decided to tolerate temporary buckles. The proposed stabilizer had flutter characteristics that were within acceptable limits.

Brief summaries of the vertical tail and speed brake structures were also presented but as these components ultimately underwent extensive modifications, the items described had little relation to the final design.

The fuselage was to be of Inconel X. A semi-monocoque structure of titanium ribs and an inner aluminum skin were to be employed in the area ahead of the propellant tanks, and that section was to be insulated with spun glass. In the area of the propellant tanks, the circular fuselage was to be of full monocoque construction. One speaker pointed out that a full monocoque design would utilize only slightly thicker skins than a semi-monocoque design, would possess adequate heat sink properties, would reduce stresses caused by temperature differences by placing all of the material at the surface, and that the resulting structure would be ideal for use as a pressure tank. The design eliminated skin

buckling and bulging, provided stiffness, had a uniformity that reduced fatigue and creep problems, and was simple to fabricate. The thickness of the monocoque walls would also make sealing easier and leaks less likely.

Fuselage problems which had not been resolved at the time of the industry conference included the reduction in buckling strength that was anticipated in the areas where the cooler internal rings of the tank bulkheads and wing support frames restrained the heated outer shell. It was known that this restraint would induce compression stresses in the shell and thereby reduce buckling strength. Another problem arose because of the side tunnels incorporated in the design. As the tunnels would protect the side portions of the circular shell from aerodynamic heating, the sides would not expand as rapidly as the areas exposed to the air and another undesirable compressive stress had to be anticipated. It was thought that beading the skin of the areas protected by the tunnels would provide a satisfactory solution but beading introduced further complications by reducing the structure's ability to carry pressure loads.

Structural design in the case of the X-15 definitely involved the propellant tanks. Each of the two main tanks was to be divided into three compartments by torus (curved) bulkheads; the two compartments furthest from the aircraft center of gravity were to be subdivided by slosh baffles. Plumbing was to be installed in a single compartment, the compartment sealed by a bulkhead, and the process repeated until all the compartments were completed. The tank ends were to be semi-torus in shape to keep them as flat as possible, to reduce weight, and to permit thermal expansion of the tank shell. This entire structure was to be of welded Inconel X. At the time of the industry conference a full-size test specimen was under construction for the purpose of testing tank pressures, external loads, temperature environments and leakage rates. A wing

support frame and a section of the fuselage tunnel were to be included in the test structure in the hope that the experimental section would provide valuable static test data prior to the completion of an actual fuselage for the X-15.

Because the X-15 was expected to produce large accelerations, it seemed best to develop a side controller that would allow the pilot's arm to be restrained by an armrest without depriving him of full control over the aircraft. At the time of the industry conference in 1956, the design for the X-15 side controller had not been definitely established but a summary of the previous experience with such controllers was available. Experimental controllers had been installed on a Grumman F9F-2, a Lockheed TV-2, a Convair F-102, and on a simulator. The pilots who had tried side controllers had reported no difficulty in maneuvering, but they generally felt that greater efforts would have to be made to eliminate backlash and to control friction forces; they had also urged that efforts be made to give the side controllers a more "natural" feel.

Another problem which had not been thoroughly explored at the time of the 1956 conference concerned the proposed reaction controls that would be necessary for the X-15 as dynamic pressures decreased to the point where the aerodynamic controls would no longer be effective. Analog-computer and ground-simulator studies were then under way in an effort to determine the best relationship between the control thrust and the pilot's movement of the control stick. Attempts were also being made to determine the amount of fuel that would be required for the control rockets. No significant problems were uncovered during these early investigations, but it was clear that the pilot would have to give almost constant attention to such a control system and that pilots who were to use this form of control should be given extensive practice on simulators before being allowed to attempt actual flight.

As in the case of the other papers presented to the 1956 industry conference, the report on ground and aircraft instrumentation was very tentative in nature. Nevertheless, plans were already well along for the establishment of ground tracking stations to assist the pilot with data and advice, to record accurate measurements, and to provide navigational assistance to both the X-15 and its mother aircraft. Such a range would also prove valuable for search in case of emergency. This ground range was to be established along a line extending from Wendover Air Force Base, Utah, to Edwards Air Force Base, California, and was to have installations at Ely and Beatty in Nevada as well as at Edwards. The range was to be equipped so as to determine velocity, range, elevation, and azimuth with radar. Engine and aerodynamic data were to be transmitted from the X-15 by telemetering and voice radio. Each ground station was to overlap the next and all were to be interconnected so that timing signals, voice communication, and radar data would be available to all. The timing signals were to originate at Edwards. Provision was to be made for recording the acquired data on tape and film; some was to be directly displayed. Design and fabrication of this complex had been undertaken by the Electronic Engineering Company of Los Angeles. Project planners estimated that the range would be ready for operation by 1958.

In the X-15 itself, provision was being made for a pressure recorder in the nose, a main instrument compartment directly behind the pilot, and for accelerometers and other small sensing devices in a center-of-gravity compartment.

Some of the anticipated difficulties in the field of instrumentation arose because available strain gauges were not considered satisfactory at the expected high temperatures and because of difficulties in recording the output of thermocouples. Large structural deformations of wings and empennage were to be recorded by cameras in special camera compartments.

Another instrumentation problem arose because the sensing of static pressure, ordinarily difficult at high Mach numbers, was compounded in the case of the X-15 by heating that would be too great for any conventional probe and by the low pressure at the high altitudes to be explored. Project personnel hoped that a stable-platform-integrating-accelerometer system could be developed to provide velocity, altitude, pitch, yaw, and roll angle information. Available accelerometer systems were limited to two axes and were too large and heavy for X-15 use, but it appeared that a three-axis platform within the space and weight limitations of the X-15 could be developed, and at the time of the meeting in 1956, manufacturer's proposals for such a system were being considered.

An unsolved problem was that of recording outside temperatures. The only solution appeared to be the use of radiosondes, but that was not completely satisfactory as such devices were limited to altitudes of about 100,000 feet, far less than the altitude to be attained by the X-15.

Still another instrumentation difficulty was created by the desirability of presenting the pilot with angle-of-attack and side slip information, especially for the critical exit and reentry periods. Any device to furnish this information would have to be located ahead of the aircraft's own flow disturbances, would have to be structurally sound at elevated temperatures, would have to be accurate at low pressures, and would have to cause a minimum of flow disturbance so as not to interfere with the heat transfer studies that were to be conducted in the forward area of the fuselage. These requirements had led to the development of a null-balance sensing device. Preliminary work had resulted in the design of a six-inch Inconel sphere capable of withstanding 1200 degree temperatures. The sphere, to be placed in the nose of the X-15, was to be gimballed and servo-driven in two planes. It was to

have five openings: a total-head port opening directly forward and two pairs of angle-sensing ports in the pitch and yaw planes, located at an angle of 30 to 40 degrees from the central port. (Pitch and yaw of an aircraft could be sensed as pressure differences and these differences converted into signals that would cause the servos to realign the sphere in the relative wind.) As a null-balance device had no source of static pressure, it was not suitable for furnishing indicated airspeed, so some alternate pitot-static system would be necessary to provide the airspeed information required for landing the X-15 safely.

The report on crew provisions and escape presented to the 1956 industry conference dealt with escape, cockpit environment, pilot's working area, flight accelerations, landing, and landing gear stability.

Two main criteria had governed the selection of an escape system for the X-15, and these two criteria were not necessarily complementary. The first requirement had been that the system be the most suitable that could be designed while remaining compatible with the airplane. The second requirement had been that no system would be selected that would delay the development of the X-15 or leave the pilot without any method of escape when the time arrived for flight testing the completed vehicle. The four possible escape systems that were considered included cockpit capsules, nose capsules, a canopy shielded seat, and a stable-seat, pressure-suit combination. An analysis of the expected flight hazards had indicated that because of the fuel exhaustion and low aerodynamic loads, the accident potential at peak speeds and altitudes was only about two percent of the total accident potential.

The final decision for a stable-seat, pressure-suit combination was made because most of the potential accidents could be expected to occur at speeds of Mach 4 or less, because system reliability

always decreased with system complexity, and finally, because it was the system that imposed the smallest weight and size penalties upon the aircraft. The selected system would not function successfully at altitudes above 120,000 feet and speeds in excess of Mach 4, but designers held that the aircraft itself would be its own best escape capsule in the areas where the seat-suit combination was inadequate.

The preliminary ejection seat design utilized a rocket-type ejection gun. One proposed version was fin-stabilized and another incorporated a skip-flow generator.\* A preliminary decision had been made to use the skip-flow type. The seat also incorporated restraining devices for the pilot's extremities.

An emergency oxygen system was to be capable of providing suit pressurization and a breathing supply for a period of twenty minutes. The pressure suit was to be similar to those already in development for high performance military aircraft. Such a suit was considered adequate for protection against the ozone hazard and it had been decided that there was no necessity for concern with exposure to cosmic rays. Concern was expressed, however, for the problem of rapid pressure changes during the various stages of the ejection sequence. Researchers concluded that careful consideration would have to be given to the possible pressure surges within the helmet and their potential for damaging the pilot's ears and lungs. It had already been determined that the proposed suit materials could withstand the maximum pressure and temperatures to which they would be subjected within the operational limits of the escape system as a whole.

The plans for the cockpit environment of the X-15 were based on the use of nitrogen. Cockpit and instrument cooling,

---

\*A skip-flow generator was a deflector that directed the air flow so as to create a low velocity area around the pilot.

pressurization, suit ventilation, windshield defogging, and fire protection were all to be provided from a liquid nitrogen supply. Vaporization of the liquid nitrogen would keep the pilot's environment within comfortable limits at all times. An interesting aspect of the cooling problem was an estimate that only 1.5 percent of the system's capacity would be applied to the pilot; the remaining 98.5 percent was required for the equipment. Cockpit temperatures were to be limited to no more than 150 degrees, the maximum limit for some of the equipment. The pilot would not be subjected to that temperature, however, as the pressure suit ventilation would enable him to select a comfortable temperature level for himself. Cockpit pressure was to be maintained at the 35,000 foot level and as the pressure suit was also designed to operate at the same level if cabin pressure should fail, there would be no pressure variations during the exploratory phases of the X-15's flights and the pilot would have adequate protection against explosive decompression. Provision was to be made for the pilot to clear the cockpit area of its nitrogen atmosphere by the use of ram air pressure.

The various switches and controls were to be selected and placed to minimize pilot movements. Instrument, warning light, and control location had been determined by analysis of the pilot's duties and instruments were to be arranged in a manner that would permit a maximum of attention to be directed toward one area at a time. Visibility from the cockpit would be excellent, but some questions remained unanswered as to the vision-degrading effects of heat distortion from the hot windshield. Key to detailed layout of the cockpit was the planned use of side controllers and the possible elimination of the center stick. Scott Crossfield, a former NACA test pilot who was to make the initial X-15 flights as a North American pilot, commented that the decision to abandon the center stick would rest on the results of further tests and the necessity to "break with tradition." (He may have reflected that



the world's first military airplane was guided with side controllers and that it had no center stick.)

The effects of flight accelerations upon the pilot's physiological condition and upon his ability to avoid inadvertent control movements had not been completely explored, but it was recognized that high accelerations could pose medical and restraint difficulties. In addition to the accelerations that would be encountered during the exit and reentry phases of the X-15's flights, a very high acceleration of short duration would be produced during the landings. This latter acceleration was a result of the location of the main skids at the rear of the aircraft. Once the skids touched down, the entire aircraft would act as if it were hinged at the skid attachment points and the nose section would slam downward. Reproduction of this landing acceleration on simulators showed that because of the short duration, no real problem existed. There were however, numerous complaints about the severity of the jolts.

The 1956 industry conference heard two papers on the proposed engine and propulsion system for the X-15. The first of these dealt only with the engine, the second with the installation of the engine and its associated systems in the aircraft. At the time of the conference the proposed XLR99-RM-1 engine was scheduled to have a variable thrust of from 19,200 to 57,200 pounds at 40,000 feet. It was to employ anhydrous ammonia, liquid oxygen and a 90-percent hydrogen peroxide solution as propellants, was to have a dry weight of 618 pounds, and a wet weight of 748 pounds. Specific impulse was to vary from a minimum of 256 seconds to a maximum of 276 seconds. The proposed engine was to fit into a space with a length of 71.7 inches and a diameter of 43.2 inches. A single thrust chamber was to be supplied by a turbopump with the turbopump's exhaust being recovered in the thrust chamber. A two-stage impulse turbine was to drive a dual inlet fuel pump and a single inlet

oxidizer pump. Thrust control was by regulation of the turbopump speed, the regulation to be accomplished by a pilot-controlled governor.\*

In the design stages of the XLR99's development, Reaction Motors was concerned with the engine's safety and reliability in terms of the requirement to produce an engine that could be throttled and that would meet the established specifications. (Another factor of some importance was the requirement that the engine should be capable of being restarted.)

The decision to control the engine's thrust by regulation of the turbopump's speed was made because the other possibilities (regulation by measurement of the pressure in the thrust chamber or of the pressure of the discharge) would cause the turbopump to speed up as pressure dropped. As the most likely cause of pressure drop would be cavitation in the propellant system, an increase in turbopump speed would aggravate rather than correct the situation. Reaction Motors had also decided that varying the injection area was too complicated a method for attaining a variable thrust engine and had chosen to vary the injection pressure instead.

The regenerative cooling of the thrust chamber created another problem for the designers as the varying fuel flow of a throttleable engine meant that the system's cooling capacity would also vary and that adequate cooling throughout the engine's operating range would produce excess cooling under some conditions. Engine compartment temperatures also had to be given more consideration than in previous rocket engine designs because of the higher radiant heat transfer from the structure of the X-15.

---

\*The engine was eventually to undergo numerous changes of detail but its basic design, as described to the conference, was not greatly altered.

The restart requirements for the XLR99 introduced some additional complications, particularly in regard to safety provisions. At the time of the conference, a two-stage ignition system was planned; the effort to produce a fail-safe design for the ignition system and the engine itself necessitated a purge system, inert gas bleed for both stages of the ignition and thrust chamber, and the duplication of numerous system components. On the other hand, the fact that both fuel and oxidizer were volatile reduced the hazard of an unsafe accumulation of propellants in the system.

Reaction Motor's spokesman at the conference of 1956 concluded that the development of the XLR99 was going to be a difficult task. Subsequent events were certainly to prove the validity of that assumption.

A second paper dealt with engine and accessory installation, the location of the propellant system components, and the engine controls and instruments. The main propellant tanks were to contain the liquid oxygen ("lox"), ammonia, and the hydrogen peroxide. The oxygen tank, with a capacity of approximately 1,000 gallons, was to be located just ahead of the aircraft's center of gravity; the ammonia tank, with a capacity of approximately 1,400 gallons, just aft of the same point. A center core tube within the oxygen tank would provide a location for a supply of helium under a pressure of 3,600 pounds per square inch. Helium was to be utilized for the pressurization of both the oxygen and ammonia tanks. A 75-gallon hydrogen peroxide tank behind the ammonia tank was to provide the monopropellant for the engine's turbopump. An additional supply of helium was to be utilized for pressurizing the monopropellant tank. The "lox" and ammonia tanks were designed with triple compartments arranged to permit both propellants to be forced toward the center of gravity as they were expelled, either during normal operations or jettisoning. The transfer tubes

between compartments demanded considerable study because the high accelerations of the X-15 would tend to force the contents of the tanks toward one end or the other. The compartmental divisions were further complicated by the necessity for efficient fueling and the need to keep the quantity of propellants remaining after burn-out or jettisoning at the lowest possible figure. As the acceleration, efficient fueling, and maximum evacuation called for features not entirely compatible, compromises were necessary. Fortunately, no insoluble problems arose during early tests.

Provision was also made for top-off of the "lox" tank from a supply carried aloft by the mother aircraft. Top-off from the mother airplane was considered to be beneficial in two ways. The "lox" supply in the mother ship could be kept cooler than the oxygen already aboard the X-15, and the added "lox" would permit cooling of the X-15's own supply by boil-off, without reduction of the quantity available for flight. The ammonia tank was not to be provided with a top-off arrangement, as the slight increase in fuel temperature during carried flight was not considered significant enough to justify the complications such a system would have entailed.

A suitable material had not yet been selected for the tank that was to contain the high-pressure, low-temperature helium supply for propellant tank pressurization. The entire propellant system presented problems difficult to foresee, primarily because of the large variations of temperature and pressure that would occur during a single flight of the X-15.

Because engine vibration characteristics were unknown, the engine mount was designed to be rigid without any special effort at vibration shielding. The engine-mount truss was to join the thrust chamber at several points and was to be attached to the fuselage by three fittings designed so that the top attachment provided the

main pivot point. The two lower fittings were to be adjustable to allow accurate alignment of the engine's thrust vector.

Three large removable doors were to provide access to the engine area and to permit observation of the engine by closed circuit television cameras during ground testing of the engine. The entire engine compartment was designed to explode open at a pressure lower than that which the forward structure was capable of withstanding, thus providing relief in case of an engine explosion. As engine compartment temperatures were not expected to be a problem, no insulation was being planned.

In 1956, the cockpit engine instruments had not been finally selected and the preliminary choices were to be altered as the engine and the propellant system were developed. A throttle with an engine prime switch was to be located on the left console, with the tank pressurization switches and jettisoning controls in the immediate vicinity of the throttle. Electric switches were to be provided for engine arming, for fire extinguisher control, and for master control. Space was allotted for several indicators to furnish the pilot with pressure information on the propellant and engine systems. A place had also been reserved for six lights to indicate various engine malfunctions. It had also been decided that the pilot would need an instrument (a totalizing impulse indicator) capable of showing the total thrust remaining at any given instant during powered flight.

The final paper presented to the 1956 industry conference was a summary of the preceding papers and of the major problems that existed at that time. The author considered flutter to be an unsolved problem, primarily because of a lack of basic data on aero-thermal-elastic relationships and because little experimental data was available on flutter at the hypersonic Mach numbers that would be reached by the X-15. He pointed out that available data

on high speed flutter had been derived from experiments conducted at Mach 3 or less, and that not all of the data obtained at those speeds were applicable to the problems faced by the designers of the X-15. He felt that the solution of the problem was full-scale robot testing of X-15 components. Another difficulty was the newness of Inconel-X as a structural material and the necessity of experimenting with fabrication techniques that would permit its use as the primary structural material for the X-15. Problems were also expected to arise in connection with sealing materials, most of which were known to react unfavorably when subjected to high temperature conditions. Preliminary wind-tunnel tests had also indicated that the original configuration of the X-15 did not have adequate stability and that modification and further testing would be essential.

The closing portion of the final paper dealt briefly with North American's schedule for drawings, jig construction, and fabrication of the aircraft.<sup>8</sup>

That the design features of the X-15 presented to the industry conference in October 1956 were only tentative was made apparent by the results of a development engineering inspection held at North American's Inglewood plant on December 12 and 13, 1956. This inspection of a full-scale mockup was intended to reveal unsatisfactory design features before fabrication of the aircraft got under way. Thirty-four of the forty-nine individuals who participated in the inspection were representatives of the Air Force, and twenty-two of them were from Wright Air Development Center. The important role of the Air Force in the determination of the X-15's design was evident from the composition of the committee chosen to review the alteration requests. Major E. C. Freeman, of the Air Research and Development Command, served as committee chairman, Mr. F. Orazio of Wright Air Development Center and Lieutenant Colonel K. C. Lindell of Air

Force headquarters were committee members, and Captain C. E. McCollough Jr. of the Air Research and Development Command and Captain I. C. Kincheloe of the Air Force Flight Test Center served as advisors. The Navy and NACA each provided a single committee member; three additional advisors were drawn from the staff of the NACA.

The inspection committee considered 84 requests for alterations, decided to reject 12, and placed 22 in a category requiring further study. The change requests covered a variety of features, including the controls, electrical and hydraulic systems, the escape system, and the power plant. Some of the accepted changes were the addition of longitudinal trim indications from the stick position and trim switches, relocation of the battery switch, removal of landing gear warning lights, rearrangement and redesign of warning lights, and improved marking for several instruments and controls. Other accepted recommendations concerned improved wiring for the fire detection system, improved insulation of sensitive electrical equipment, inclusion of an overheat warning system for hydrogen peroxide compartments, and the relocation of some of the electrical wiring in order to protect it from hydraulic fluids and to reduce the possibility of damage during the installation and removal of equipment. Inspection personnel also requested that the escape system be provided with better markings, that safety pins be identified by streamers, and that a dependable linkage be installed between the canopy and seat catapult initiator. Still other approved changes concerned such items as a lock for the "lox" filler cover, and improvement of the hydraulic system by the substitution of some components and by better installation and marking. The landing gear was the subject of a number of suggestions, including the elimination of cadmium plating on certain heat treated steels employed in the gear, provision for inspection panels, the use of new tires on each of the early flights, and for additional design and testing of all components of the skids and nose gear.

The requested changes in the propulsion system were concerned with the improvement of the hydrogen peroxide system by the inclusion of better leak protection methods, by better support for the tanks, and relocation of shut-off valves. Inspection personnel also recommended attention be given to keeping engine components in locations where they could be easily inspected and maintained, that adequate drainage and ventilation be provided for the engine compartment, that North American provide engine mounts to Reaction Motors in order to simplify engine handling and installation, and that engine mount bolts be safetied. Improvements were also asked in the design of the jettisoning system and in the identification and marking of the propellant system's components.

Some of the most interesting of the proposed changes were rejected by the committee. For instance, the suggestions that the aerodynamic and reaction controller motions be made similar, that the reaction controls be made operable by the same controller utilized for the aerodynamic controls, or that a third controller combining the functions of the aerodynamic and reaction controllers be added to the right console, were all rejected on the grounds that actual flight experience was needed with the controllers already selected before a decision could be made on worthwhile improvements or combinations. As two of the three suggestions on the controllers came from potential pilots of the X-15 (J. A. Walker of the NACA and Captain Kincheloe), it would appear that the planned controllers were not all that might have been desired. A warning light for the canopy lock was also rejected, as was the suggestion that the pilot be provided with easier entrance and exit by extension of the canopy's travel--both on the grounds that the existing provisions were adequate. Simplification of the hydraulic system on the first airplane was ruled out on the basis that there was nothing that could be spared. A request that the pilot be provided with continuous information on the nose-wheel door position (because loss of the door could produce severe



structural damage) was rejected because the committee felt that the previously approved suggestion for gear-up inspection panels would make such information unnecessary. A suggested study of the ignition and fire hazard potential of the various mixtures that might accumulate in the engine compartment was held to be unnecessary in light of the ventilation provisions for that compartment. Joining the auxiliary power plant exhausts in a single manifold to avoid out-of-trim moments if one auxiliary power plant should fail was not felt to be necessary. A suggested addition of check valves in the hydrogen peroxide system was considered to have been adequately taken care of by previously accepted suggestions. A request for entirely separate systems for each auxiliary power unit and for the ballistic controls was supported by the argument that separate systems had been requested earlier. (Such separate systems had been accepted during the meetings held at the North American plant in the fall of 1955.) In spite of the earlier plans for such separate systems, the committee held that with the addition of shut off valves, the system would be adequate as installed.

An even more surprising rejection of a requested change occurred in regard to changeable leading edges. An NACA representative (Harry J. Goett of Ames Aeronautical Laboratory) asked that the lower flange of the front spar be widened and that the ballistic roll controls be moved to the rear of the same spar. He justified these requests on the grounds that the research goals for the X-15 included investigations to determine the best materials, profiles, and cooling methods for various leading edges; that interchangeable leading edges had been a part of the original proposals; and that North American had originally agreed to make the leading edge detachable. In spite of Mr. Goett's apparently logical arguments, the committee decided his request could not be honored. The reasons for their rejection of the request were that North American had already determined to use a solid plate for the

lower wing surface and that the required changes would impose a three-pound weight penalty. It seemed to at least one participant that the negative decision on interchangeable leading edges marked the abandonment of a feature that would have considerably enhanced the research value of the X-15.

That a number of design features still were unsettled as late as the mockup inspection of December 13, 1956, was indicated by the 22 change requests placed in a category requiring further study. Some of these deferred requests were concerned with the B-36 carrier aircraft, which was eventually eliminated; other change requests required feasibility studies, however, and some needed further study as to desirability. The deferred requests included such suggestions as the complete elimination of the center control stick, a study of antenna locations to insure there would be no adverse effects on directional stability, the installation of an engine ignition gauge, a "lox" top-off indicator, and improvements in the rigidity and alignment of the accelerometer mounts. Doubts were expressed about the adequacy of a single antenna for transmitting and receiving radar signals and further studies were promised. A request for hydraulic pressure indication when both generators were out was also deferred until it could be determined if such indication was feasible. Three deferred requests on the escape system involved the continuing development of seat and pressure suit by further sled and tunnel tests, a study to determine the desirability of a spoiler plate to be located ahead of the cockpit and operated in the canopy ejection sequence, and the selection of an improved location for the canopy's emergency release handle.

Other requests which the committee decided to be worth further study included the replacement of machine screws by quick fasteners for some of the fuselage access panels, vibration testing of propellant lines, relocation of components of the helium system to

minimize the possibility of leaks, and the use of expulsion bags in the hydrogen peroxide tanks. Further study was to be conducted to determine the best type of bag or diaphragm for hydrogen peroxide expulsion, the adequacy of the helium tank mounts, the ability of the propellant lines to withstand stresses imposed by engine misalignment, and the feasibility of starting the engine ignition system prior to launch. A request to approve the shift of all controls and switches to locations where they could be easily reached from the pilot's normal seated position, (even when the pilot was of small stature), received the "further study" classification, but in this case the group also authorized such changes as appeared necessary.<sup>9</sup>

After the completion of the development engineering inspection, the X-15 airframe design changed only in relatively minor details. North American essentially built the X-15 described at the industry conference in October and inspected in mockup in December. (Continued wind tunnel testing resulted in some external modifications, particularly of the vertical tail, and some weight changes occurred as plans became more definite.) But while work on the airframe progressed smoothly, with few unexpected problems, the project as a whole did encounter difficulties, some of them serious enough to threaten long delays. In fact, North American's rapid preparation of drawings and production planning served to highlight the lack of progress on some of the components and sub-systems that were essential to the success of the program.

## NOTES

1. Report on Progress of the X-15-1956, pp. 23-31; ltr., Damberg to Bell, 30 Dec. 1954.
2. Memo., A. W. Vogeley, Aero. Res. Scientist, NACA, to Res. Airplane Proj. Leader, Langley Aero. Lab., NACA, 30 Nov. 1955, subj.: Project 1226 meetings to discuss changes in the North American Proposal - Wright-Patterson Air Force Base meeting of October 24 and 25, and North American Aviation meetings in Los Angeles on October 27 and 28 and November 14 and 15, 1955.
3. Memo., W. C. Williams, Ch., NACA High Speed Flt. Station, Edwards AFB, Calif., to Res. Airplane Proj. Leader, Langley Aero. Lab., NACA, 27 Jan. 1956, subj.: Visit to North American Aviation, Inc. to discuss Project 1226.
4. Memo., H. A. Soulé, Res. Airplane Proj. Leader, Langley Aero. Lab., to Members, NACA Res. Airplane Proj. Panel, 7 June 1956, subj.: Project 1226-Progress report for month of May 1956.
5. Ibid.
6. DF, M. A. Todd, Actg. Ch., Contr. Reporting and Bailment Br., Support Div., to Ch., Ftr. Br., Ac. Div., Dir/Proc. and Prod., AMC, 15 June 1956, subj.: Confirmation of Serial Numbers Assigned.
7. Ltr., Dr. H. L. Dryden, Dir/NACA, to Ch., Ftr. WSPO, Dir/Sys. Mgmt., ARDC, 6 July 1956, no subj.
8. Report on Progress of the X-15-1956, pp. 1ff.
9. Rpt., "Development Engineering Inspection of the X-15 Research Aircraft-13 December 1956," Dir/Sys. Mgmt., ARDC, in files of X-15 WSPO.

## CHAPTER III

### THE PROPULSION STORY

Those concerned with the success of the X-15 had to monitor the development of the proposed XLR99 rocket engine, the auxiliary power plants, an inertial system, a tracking range, a pressure suit, and an ejection seat. They had to make arrangements for support and mother aircraft, for ground equipment, for the selection of pilots, and for the development of simulators for pilot training. It was necessary to secure time on centrifuges, in wind tunnels and on sled tracks. The NACA "Q-ball" nose had to be developed, studies made of the compatibility of the X-15 and the mother aircraft, other studies on the possibility of extending the X-15 program beyond the goals originally contemplated and on the potential of the X-15 as a trainer in other space programs. In addition to such tasks, funds to cover ever increasing costs had to be secured if the project were to have any chance of ultimate success, and at certain stages, the effects of possibly harmful publicity had to be considered. With such multiplicity of tasks, it could be expected that difficulties would be encountered and several serious problems did arise. Probably the most serious difficulties, and certainly those which gave rise to the greatest concern, arose during the development of the XLR99 engine.

A suitable engine for the X-15 had been somewhat of a problem from the earliest stages of the project, when the WADC Power Plant Laboratory had pointed out that the lack of an acceptable rocket engine was the major shortcoming of the NACA's original proposal. While the Power Plant Laboratory felt that the Hermes A-1 engine selected by the NACA planners was not capable of being developed into a safe engine for a manned vehicle, no very practical

alternative was immediately available. The laboratory did suggest several engines "more suitable" for manned aircraft, but essentially WADC urged further study before the final selection of a specific engine. In October 1954, the representatives of the Air Force, Navy, and NACA, who were planning the X-15 competition, selected four engines as possible X-15 power plants. They did not forbid proposals to use engines other than those named, but a bidder who desired to utilize another engine was faced with the additional complication of joining with the manufacturer of the proposed engine to produce a justification for the selection of a non-listed item. The justification was to be presented to the Weapon System Project Office and that office could approve or disapprove the use of the engine.<sup>1</sup>

The first really concrete descriptions of the proposed X-15 engines appeared in correspondence of November 15, 1954. Mr. T. J. Keating, chief of the Non-Rotating Engine Branch, Power Plant Laboratory, wrote Mr. J. B. Trenholm, of the systems directorate, as a result of a conference of October 22, 1954. The conference, held at the Directorate of Laboratories and attended by representatives of the Navy, Air Force, and the NACA, had been for the purpose of planning the procurement procedures to be followed in selecting a contractor for the X-15. Those attending the conference evidently felt that they did not have adequate information on rocket engines; Mr. Keating's note constituted a summary of the status of rocket engines under development at that time, particularly those that seemingly could, with further development, be made into suitable power plants for the X-15.

The Power Plant Laboratory did not believe that any available engine was entirely suitable for the X-15 and held that no matter what engine was accepted, a considerable amount of development work could be anticipated. Most of the possible engines were either too small or would need too long a development period. In spite of

these reservations, the laboratory listed a number of engines worth considering and drew up a statement of the requirements for an engine that would be suitable for the proposed X-15 design. The laboratory also made clear its stand that the government should "accept responsibility for development of the selected engine and . . . provide this engine to the airplane contractor as Government Furnished Equipment."<sup>2</sup>

The primary requirement for an X-15 engine, as outlined by the Power Plant Laboratory in 1954, was that it be capable of operating safely under all conditions. Service life would not have to be as long as for a production engine, but engineers hoped that the selected engine would not depart too far from production standards. The same attitude was taken toward reliability, that is, the engine need not be as reliable as a production article, but it should approach such reliability as nearly as possible. There could be no altitude limitations for starting or operating the engine, and the power plant would have to be entirely safe during start, operation or shutdown, no matter what the altitude. The engine was also to be capable of safe operation under the highest "g" conditions to be encountered during the operation of the X-15.

The Power Plant Laboratory did not try to define the exact thrust values to be attained by the selected engine, holding that such a determination would have to await a more complete definition of the aircraft itself. However, the laboratory did make it quite clear that a variable thrust engine capable of repeated restarts was essential. Again, laboratory specialists did not try to set the range of variability or the number of restarts, preferring to wait until more was known about the X-15 design itself.

The laboratory also warned that none of the engines tentatively selected was entirely satisfactory for the proposed program; the list was composed of engines with the best possibilities for

development into a suitable power plant for the X-15. To assist in evaluation, the Power Plant Laboratory prepared a summary of the current status of each engine, and forwarded an estimate of necessary changes to development objectives and development schedules in order to produce an adequate engine within the time limit imposed by the X-15 program.

The engine ultimately selected was not one of the four originally presented as possibilities by the Power Plant Laboratory. The original list included the Bell XLR81, the Aerojet General XLR73, North American's NA-5400 and Reaction Motors' XLR10. The ultimate selection was foreshadowed, however, in discussions of Reaction Motors' XLR10, during which attention was drawn to what was termed "a larger version of Viking engine (XLR30)."<sup>3</sup> In the light of subsequent events, it was interesting to note that the laboratory thought the XLR30 could be developed into a suitable X-15 engine for "less than \$5,000,000" and with "approximately two years' work."<sup>4\*</sup>

(The AMC letter of December 30, 1954, which invited selected members of the aircraft industry to participate in the development of a new research aircraft, incorporated the Power Plant Laboratory's recommendations of November, in their entirety.)<sup>5</sup>

During the month of January, additional interest was shown in the XLR30 engine as a possible X-15 power plant; on January 25, 1955, AMC asked Reaction Motors for additional details on that company's engines.<sup>6</sup> Reaction Motors replied on February 3, 1955 by elaborating on the details of both the XLR10

---

\*In fairness to the laboratory, it must be admitted that such estimates were accompanied by a statement that "less confidence in these estimates exists because the XLR30 engine is at present in a much earlier stage of development." It was this same XLR30 that was eventually to be turned into the XLR99 and which was to prove the laboratory's qualification of its estimates to have been justified.



and the XLR30. The firm recommended four possible combinations as being suitable for the X-15 program: an XLR30 using liquid oxygen and anhydrous ammonia, an XLR30 using liquid oxygen and a hydrocarbon fuel, an XLR10 using liquid oxygen and ethanol, and an engine to be composed of two XLR10 chambers fed by a single XLR30 turbopump. All four versions utilized hydrogen peroxide for turbopump drive. Evidently Reaction Motors already had an idea of what the airframe contractors were planning, for the company frankly stated doubt that one XLR10 was "adequate to perform the objectives of this type of aircraft." Reaction Motors also recommended against an attempt to make the XLR30 operable with hydrocarbon fuel, largely because the company felt this version of the engine would require a longer development period than would the version utilizing anhydrous ammonia. Again, Reaction Motors preferred the XLR30 over the proposed combination of XLR10 thrust chambers with an XLR30 turbopump. This last choice was made because, at relatively the same cost, the single chamber XLR30 would result in a simpler and more reliable engine. Reaction Motors also pointed out that the volatility of anhydrous ammonia would make for safer restarts, that the XLR30 would need fewer parts, it would be simpler to install than the configuration utilizing two XLR10 chambers.

In summing up arguments for the XLR30 utilizing ammonia as a fuel, Reaction Motors stated that the cost of such an engine would be as low as any of the configurations, that it would be simpler and more reliable, and that its weight would be only 420 pounds compared to 815 pounds for the double-chambered engine. The company also estimated that the XLR30 could be throttled to 30 percent of full thrust, permitting a variation between 17,000 and 57,000 pounds of thrust at 40,000 feet. A specific impulse of 278 seconds seemed possible at full rated thrust. The compact size of the XLR30 (installation space was to be 30 inches in diameter and only 70 inches in length) was given as an additional reason for preferring that engine over the larger XLR10-XLR30 combination.<sup>7</sup>

While Reaction Motors was clearly interested in promoting the anhydrous ammonia version of the XLR30, the Air Force still favored the XLR10. On February 4, 1955, AMC asked Reaction Motors for still more detailed information on the XLR10.<sup>8</sup> On the same date a conference between Reaction Motors and the Air Force decided that all data submitted for the proposed X-15 engine would be for the XLR30 rather than for the XLR10. The Reaction Motors' representatives indicated that the XLR10 would need considerable development if it was to be made into a safe engine at all flight attitudes. They contended that since both engines required further development, the XLR30 was the better choice because it would ultimately be a superior engine. Reaction Motors' opinion prevailed, and on February 24, the company was advised that it "should make all further estimates on the basis of the XLR30's development."<sup>9</sup>

The engine information submitted by Bell, Aerojet, and Reaction Motors was forwarded to the prospective airframe bidders on March 18, 1955.<sup>10</sup>

On March 22, the project office forwarded its comments on the data furnished three days earlier. Among the comments was the statement that the Bell and Aerojet engines would probably have to be used in multiples if the thrust requirements of the X-15 were to be met. Prospective contractors were also advised that the engine that was eventually to be furnished would be capable of safe operation, whether or not fuel and oxidizer exhaustion was signaled to the pilot. The fact that the developed engine was not being considered as a production item was made clear, and the airframe manufacturers were told that the operating time of the engine should only be limited by the amount of the propellants available. The prospective contractors were optimistically told they could expect the selected engine to be ready for flight test use within 30 months after the airframe contract was signed, but they were

also warned that there probably would be some change in weights as a result of the development effort.<sup>11</sup>

On April 26, 1955, WADC received approval from Headquarters ARDC for a plan to require detail configurations of the engines involved in the X-15 program. Command headquarters requested that "the engine program be subjected to a final critical review apart from, but concurrent with the evaluation of the airframe proposals." WADC was advised to get a firm commitment from each of the engine contractors and to include the results of the engine evaluations in support of the recommendations on the X-15 itself.<sup>12</sup>

On June 20, 1955, the Directorate of Weapon Systems Operations asked the Power Plant Laboratory for an evaluation of the proposed engines for the X-15. The laboratory was advised that the evaluation was to be conducted in cooperation with the Navy and NACA, and that the results were needed by July 12.<sup>13</sup> Results of the requested evaluation were forwarded to the project office in mid-July. Evaluations were based in part on briefings presented by the contractors on June 14 and on the outcome of evaluation meetings held on June 15 and on July 6 and 7.

The evaluation group reported that none of the proposed power plants had sufficient superiority over the others to justify changing the engine selected by the contractor with the best X-15 design. As none of the X-15 proposals included the Aerojet engine as a first choice, that company's XLR73 was eliminated from final consideration.\* The evaluators felt that the Bell engine was more

---

\*Of the engines under consideration, only the Aerojet XLR73 was a funded development engine. Consequently, the XLR73 was the only engine which--theoretically at least--would have cost nothing additional.

likely to be developed within the time limits of the project but that its superiority in this respect was so small as not to dictate its choice over the engine proposed by Reaction Motors. At the time of the evaluation, the cost of the Bell engine was estimated at \$3,614,088 while a figure of \$2,699,803 was given for the engine proposed by Reaction Motors.

In comparing the relative merits of the Bell and Reaction Motors' proposals, the Power Plant Laboratory pointed out that the internal fuel and gas generator systems of the Bell design each utilized two fuels interchangeably and that this feature made for complicated valving and fuel flow systems. It seemed probable that the separate starting system for meeting the repeated start requirements of the X-15 engine would create some problems of safety and reliability. The Reaction Motors' engine, while more orthodox than the Bell, had been little tested. The laboratory correctly predicted that difficulties would be encountered in attempting to achieve an acceptable service life and the required degree of reliability. In considering the safety of the two designs, the laboratory reported that Bell had more experience than had Reaction Motors, but that both designs would need additional development before either could be considered a safe engine for a manned aircraft. The laboratory was also correct in predicting that the thrust chamber cooling of the Reaction Motors' design might present some difficulty.

The Power Plant Laboratory judged the designs on the basis of their feasibility, safety, reliability, performance characteristics, weight, installation requirements, the magnitude of development problems, the capability of the contractor, and the applicability of the engine for the proposed missions of the X-15. The laboratory's report pointed out that the airframe designers would undoubtedly take other factors into account, factors such as the nature of the propellants and their weight, the number of

controls required, and the merits of multiple versus single engine installations.

An additional factor which, in the view of the Power Plant Laboratory, had not been given adequate consideration by the airframe contractors or by the evaluation rules, was that of minimum thrust. The laboratory stated that if a requirement existed for operation of the engine at less than 50 percent of the rated thrust, such a requirement would have an important bearing on engine selection. It was intimated that the laboratory's evaluation would have been different if one of the design objectives had specified an engine capable of operating at half or less than half of the rated thrust.

The Power Plant Laboratory's evaluation, while making no major distinction between Reaction Motors' proposals and those of Bell, left the definite impression that the Bell design was favored. Nowhere was this more clearly apparent than in the laboratory's statements that the ". . . Bell engine would have potential tactical application for piloted aircraft use whereas no applications of the RMI engine are foreseen," and "in the event that the XLR73 development does not meet its objectives, the Bell engine would serve as a 'backup' in the Air Force inventory."

Looking forward to the actual selection of one of the two proposals under consideration, the laboratory made recommendations on the course of development that should be followed. In the case of the Bell engine, evaluators suggested that hydrogen peroxide be considered for the turbine drive, and that an effort be made to simplify starting and to reduce the development effort by substituting unsymmetrical dimethyl hydrazine for JP-X. If the Reaction Motors' design emerged as the final selection, it would meet laboratory recommendations that the throttling range be restricted in order to reduce the development effort, that

consideration be given to converting the engine from ammonia to JP-4 to reduce corrosion and handling problems, and finally, that an NACA suggestion to use an interim "off-the-shelf" engine for initial flight testing be adopted.<sup>14</sup>

Apparently little attention was paid to these recommendations as the throttling range was not reduced, ammonia was retained as a fuel, and no consideration was given to the use of an interim engine until development difficulties compelled the selection of such an engine in early 1958.

After North American had been selected as the winner of the X-15 competition, plans were instituted to procure the modified XLR30 engine that had been incorporated in the winning design. Late in October, Reaction Motors was notified that North American had won the X-15 competition and that the winner had based his proposals upon the XLR30 engine.<sup>15</sup>

On December 1, 1955, the New Developments Office of Fighter Aircraft Division, Directorate of Systems Management, asked the Power Plant Laboratory to initiate a purchase request that would provide \$1,000,000 for a proposed letter contract with Reaction Motors.<sup>16</sup> On December 8, the Air Materiel Command asked Reaction Motors to submit a proposal that would permit the Air Force to prepare a contract covering the development of an engine for the X-15. AMC suggested that the proposal contain visual presentations of a proposed development program, a chart of important milestones, and various cost estimates. The materiel organization also asked Reaction Motors to provide information on the amount of testing anticipated and contractor capabilities for conducting the required tests.<sup>17</sup> The letter requesting a proposal from Reaction Motors included a preliminary informal work statement and list of the minimum requirements for the modified XLR30 engine. The content of the attachments differed only slightly from the requirements eventually incorporated in the formal contract.<sup>18</sup>

While preliminary steps were being taken to procure the required engine, the Power Plant Laboratory raised a further question as to the desirability of the engine selected. The NACA had, as a result of preliminary discussions with Reaction Motors, expressed concern that the ammonia fuel might have an adverse effect on planned instrumentation and had asked that the possibility of converting to another fuel be given further study. The Power Plant Laboratory, already convinced that the contractor's estimate of a two-year development period was much too optimistic, viewed any change with disfavor. The laboratory had been reluctant to accept a two-and-one-half year estimate during the original evaluation of the proposed X-15 engines, holding that a three year period was probably more realistic. Propulsion engineers estimated that a change in fuels would extend the development period to four years, and the laboratory held that such an extension would make the original evaluation invalid. If a four-year development period was to become acceptable, the laboratory recommended a re-evaluation that would permit reconsideration of engines that had considerable potential but which had been eliminated from the original evaluation because their development period had been estimated at more than two and one-half years.<sup>19</sup>

In late December, the Power Plant Laboratory advised the project office that whatever procurement procedure was followed in securing an engine for the X-15, certain features should be insisted upon. Among the features that the laboratory felt to be important were the retention of Reaction Motors as the engine contractor, a requirement that North American could not change the engine selection without prior approval of the project office and the Power Plant Laboratory, and a provision for close coordination and direct contact between the laboratory and Reaction Motors, no matter what contractual procedure was utilized.<sup>20</sup>

The end of 1955 was also marked by a skirmish over the assignment of cognizance for the development of the engine. The

skirmish began with a letter to Air Force headquarters for Rear Admiral W. A. Schoech, assistant chief for research and development in the Bureau of Aeronautics. Admiral Schoech contended that since the XLR30-RM-2 rocket engine was the basis for the X-15 power plant, and the Bureau of Aeronautics had already devoted about three years to the development of that engine, it would be logical to assign the responsibility for further development to the Navy. The admiral felt that retention of the program by the bureau would expedite development, especially as the Navy could direct the development toward an X-15 engine by making specification changes rather than by negotiating a new contract. Other arguments advanced for bureau retention of the project included the close and satisfactory working relationships between the bureau and Reaction Motors and the ability of the Navy to make the facilities at Lake Denmark available for the program. The Navy's extensive experience with hydrogen peroxide was also put forth as a justification for continuing the program under the Bureau of Aeronautics.<sup>21</sup>

Air Force headquarters sent the admiral's letter to the commander of the Air Research and Development Command on December 9 asking for resolution and comment by January 3.<sup>22</sup> On December 29 a teletype conference was held between ARDC headquarters and personnel from ARDC Detachment One at Wright Field. The Navy's bid for responsibility for the development of the engine had apparently been forwarded to Detachment One and the Power Plant Laboratory for comment, as the conference was devoted to refutation of the arguments advanced by the Bureau of Aeronautics for retention of the engine program.<sup>23</sup>

ARDC headquarters summarized the arguments of Detachment One and the Power Plant Laboratory and forwarded the summary to Air Force headquarters on January 3, 1956. The Navy's bid for control of the engine development was rejected on the grounds that the management responsibility should be vested in a single agency, that



conflict of interest might generate delay, and that the Bureau of Aeronautics was underestimating the time and effort that would be needed to make the XLR30 a satisfactory engine for manned flight.

The arguments for Air Force retention of control were based on the fact that the Power Plant Laboratory was acquainted with the status of Reaction Motors' developments, that it had experience with several similar projects for the development of rocket engines for manned aircraft, and that experienced personnel were available to monitor the program. The ARDC letter also pointed out that past experience had shown that more problems could be expected in the assembly of components into an operating engine and adaptation of the engine to the airframe than in the development of components--and the Navy's experience with the XLR30 had been largely with component development. As the original Bureau of Aeronautics letter had raised the problem of the availability of test facilities, ARDC noted that the Air Force was already using Reaction Motors' facilities and could expect that those facilities would be made available for the XLR30 program. Admiral Schoech's letter had also stated that plans called for the use of an XLR8-RM-8 as an interim engine and that the Bureau of Aeronautics' knowledge of this engine was an additional reason for assigning engine development to the Navy. This last contention was denied with the flat statement that there were no plans for the use of an interim engine.<sup>24</sup>\*

Apparently the Bureau of Aeronautics accepted the Air Force's decision that engine development was to remain an Air Force responsibility for there was no evidence of additional correspondence on the subject.

---

\*In fact, of course, the X-15 eventually did require use of the XLR8 as an interim engine, when the XLR30's derivative, the XLR99, fell further and further behind schedule.

The Navy's bid for cognizance over engine development may have served to hasten the procurement procedures; Reaction Motors was furnished with a final work statement and the performance requirements for the engine on January 4, 1956, the day after ARDC's comments on the Bureau of Aeronautics' letter went forward to Air Force headquarters.<sup>25</sup> The Power Plant Laboratory received Reaction Motors' technical proposal on January 24 and the company's cost proposals on February 8.<sup>26</sup>

The cover letter which accompanied the various reports and cost breakdowns from Reaction Motors promised delivery of the first complete system "within thirty (30) months after we are authorized to proceed."<sup>27</sup> The same letter marked the abandonment of the XLR30 designation that had been used for convenience in previous discussions of the proposed X-15 engine. Reaction Motors, recognizing that the developed engine was going to have numerous differences from the XLR30, gave the new design a "company designation," TR-139. (On February 21 the Power Plant Laboratory formally requested assignment of an XLR99-RM-1 designation.)\* Reaction Motors also estimated that the entire cost of the program would total \$10,480,718, stated that the company would prefer that the fee be determined by later negotiation, and noted that preliminary design and liaison work had begun on January 1 in anticipation of a contract award.<sup>28</sup>

Evidently the rate at which the procurement negotiations were proceeding was unsatisfactory to the NACA, for on February 15 Brigadier General V. R. Haugen, then the WADC deputy commander for development, felt it necessary to reassure the NACA that he had investigated the apparent delay in awarding the engine contract and had determined that the procurement procedures were moving at an acceptable pace.

---

\*The designation became "official" at Wright-Field on March 6 and received Navy approval on March 29.

General Haugen pointed out that nearly one month of the time that had elapsed since procurement was authorized on October 27, 1955 had been consumed by a study of the NACA suggestion for changing from ammonia to another fuel. The general estimated that a letter contract would be issued no later than March 1.<sup>29</sup> (As a matter of fact, his letter was dated one day after the date of the letter contract.)<sup>30</sup>

While the procurement difficulties were relatively minor, and in retrospect seemed to have consumed a relatively small portion of the time eventually devoted to the new engine, it was not long before other and serious questions were being posed.

Less than two months after General Haugen's letter to the NACA, that organization was criticizing Reaction Motors' conduct of the program. Mr. John L. Sloop, of the NACA's Lewis Laboratory, visited the company's facilities on April 11, 1956, and his report of the visit contained a list of the anticipated development problems. The problems included the provision of an adequate ignition system for the ammonia fuel, achievement of safety under all conditions, assurance that the design would be capable of meeting the severe environmental temperatures to be encountered, attainment of the performance requirements, and the development of a throttling system that would give combustion and cooling stability throughout the throttled range.

Mr. Sloop reported that Reaction Motors had assigned about a dozen engineers to the project and that they were receiving support from some 28 other staff members. He also included a summary of the company's development schedule which showed integration of a complete engine was to start in May 1957. Neither of these items drew approval from the NACA spokesman, who thought Reaction Motors' effort inadequate. Mr. Sloop also questioned the validity of the company's estimate that essential test stands would be ready in

late 1956; NACA felt this date to be optimistic by a year. Sloop also suggested that Reaction Motors place considerably more effort on the development of the engine, that the company was pursuing too many different goals without adequate basic information, and that a company proposal to study "spaghetti tube" bundle fabrication\* had small potential value in view of the fact that they had already been studying the problem for about five years.<sup>31</sup>

The first indication of Air Force concern with Reaction Motors' progress appeared in a letter from Mr. H. P. Barfield, assistant chief of the Non-Rotating Engine Branch of the Power Plant Laboratory on August 1, 1956. Barfield inquired as to why the tests of the thrust chamber, programmed for April in Reaction Motors' original proposals, had not yet taken place.<sup>32</sup>

Reaction Motors explained that the delay was the result of using the company's facilities for work on other Air Force projects, such use extending beyond the period originally contemplated. The company also admitted having subordinated the preparation of hardware to a program of engine design studies. It was the company's opinion that the preliminary design studies were of more importance in the maintenance of the schedule than were the thrust chamber tests. The delay in testing was also attributed to the modification of the two available test chambers, modifications intended to extend the chambers' utility for test purposes. Pump failures that had required three teardowns were also offered as justification for the company's failure to meet its planned development schedule.<sup>33</sup>

By February 1, 1957, North American was also becoming perturbed at the lack of progress in engine development. R. H. Rice, vice president and general manager of North American, estimated that the

---

\*The term "spaghetti tube" graphically described the appearance of the injector devices that sent fuel to the combustion chamber.

engine was already four months behind schedule. He also held that the engine's weight was growing while its specific impulse was deteriorating. North American, in an attempt to accelerate the development of the engine, asked Major General H. M. Estes Jr., ARDC's assistant deputy commander for weapon systems, to cooperate in securing "additional effort on the part of Reaction Motors, Inc."<sup>34</sup>

North American's request for cooperation initiated a flurry of activity that included meetings between Air Force and Reaction Motors on February 12 and 18 and a meeting of personnel from those organizations with representatives of North American and the NACA on February 19. The meeting confirmed North American's fears that the engine program was four months behind schedule and that engine weight was increasing. The deterioration of performance appeared to be less serious than North American had anticipated. General Estes, in his reply to Mr. Rice's letter of February 1, advised that "every effort will be expended to prevent further engine schedule slippages."<sup>35</sup>

Although General Estes' letter appeared to be reassuring, the NACA report of the February meetings was not optimistic. Hartley A. Soule, NACA's research airplane projects leader, reported that the meeting of February 19 had resulted in a decision to accept the four months' delay in delivery, but that Reaction Motors had agreed to deliver two operable engines instead of one by September 1, 1958. The decrease in specific impulse (from 241 to 236 seconds) was also accepted. The weight had increased from 588 to 618 pounds. Mr. Soule pointed out that no thrust chamber runs had been made and expressed doubt that the new schedule could be achieved. It was his opinion that the Power Plant Laboratory might be forced to accept delivery of a lower performance "first phase" engine if the proposed flight schedule for the X-15 were to be maintained. He also noted that additional engine progress meetings

were to be held in June and September, and that the NACA had promised Reaction Motors its assistance in a program to increase performance by redesigning the exhaust nozzle for higher altitudes.<sup>36</sup>

Additional assistance was to be provided by WADC's Power Plant Laboratory. Reaction Motors had been concentrating on a "spaghetti" type fuel injector which consisted of bundled metal tubing. Captain K. E. Weiss, the Power Plant Laboratory's XLR99 project engineer, designed a number of "spud" injectors that utilized small perforated disks. Several of Captain Weiss' designs were built in Wright Field machine shops and run through firing tests during the first part of 1958. By March, one of the designs had proved so promising that Reaction Motors considered adapting it to the XLR99 engine. The company, however, had had some success with its own "spud" designs, and eventually it utilized its own design in preference to the laboratory-developed injector.<sup>37</sup>

(On March 29, 1957, Captain Weiss--then a lieutenant--had submitted a management report that indicated an increase in engine costs to a new total of \$14,000,000--plus fee!)<sup>38</sup>

Unfortunately, Mr. Soule's premonition that the revised schedule and performance specifications established in February were unrealistic proved entirely correct. On July 10, 1957, Reaction Motors advised Wright Air Development Center that an engine satisfying the February specifications could not be developed unless the government agreed to a nine-month schedule extension and an increase in cost from \$15,000,000 to \$21,800,000. At the same time, Reaction Motors offered to provide an engine of the specified performance within the established time limits if permitted to increase the weight from 618 pounds to 836 pounds. The company estimated that this overweight engine could be provided for \$17,100,000. Representatives of North American, Reaction

Motors, and of all the government agencies involved in the X-15 program met at WADC on July 29 to consider the effects of an overweight engine on the performance of the X-15. The deterioration of performance was generally considered to be a lesser evil than the increased cost and additional delay that would be incurred by insistence upon a "specification" engine.

Those who hoped that the over-all performance of the X-15 could be maintained were somewhat encouraged by Reaction Motors' report that the turbopump was more efficient than anticipated and that this would allow a reduction of 197 pounds in the weight of the hydrogen peroxide necessary to its operation. The decrease in the amount of required hydrogen peroxide, the possibility that North American might remain under specified airframe weight and reduce ballast requirements, together with the increase in launch speeds and altitudes provided by the substitution of a B-52 for the B-36 carrier, offered some hope that the original goals might still be achieved. At the time of the July meeting, Reaction Motors was still experiencing difficulties with the thrust chamber and the injector assemblies. The chief problem was the burnout of the oxidizer tubes of the "spaghetti" type injector at low thrust levels. NACA and the Air Force advised the company to continue the development of the injectors and agreed to consider relaxing the minimum thrust requirements if the difficulties continued. The possibility of switching to a spud injector was also discussed, but a final decision on such a change was deferred.<sup>39</sup>

Despite the relaxation of the weight requirements, the engine program failed to proceed at a satisfactory pace. On December 11, during a meeting at the Propulsion Laboratory,\* Reaction Motors reported a new six-month slippage in the schedule. At that point,

---

\*The Power Plant Laboratory and Propeller Laboratory had been combined on June 17, 1957, the new organization being designated Propulsion Laboratory.

the company attributed its continued difficulties to a malfunction which destroyed the first development engine, to a series of pump failures, and to inability to produce an injector that would meet both performance and durability requirements. The failures were compounded because pump shortages had delayed the injector tests.

The threat to the entire X-15 program posed by these new delays was a matter of serious concern. Major General S. T. Wray, Wright Air Development Center's commander, working with General Haugen, then ARDC's director of systems management, decided to have the Directorate of Laboratories explore the technical and managerial problems involved. As a result, on January 7, 1958, Reaction Motors was asked to furnish a detailed schedule and to propose means for solving the difficulties. The new schedule, which reached WADC in mid-January, indicated that the program would be delayed another five and one-half months and that costs would rise to \$34,400,000--almost double the cost estimate of the previous July.<sup>40</sup>

On January 28, 1958, General Haugen and General Wray, accompanied by Propulsion Laboratory and X-15 project office personnel, visited Reaction Motors to discuss the lack of progress on the XLR99 and to determine what steps the company was taking to improve its performance. General Haugen emphasized the importance of the X-15 project and commented upon Reaction Motors' record up to that time. Evidently the comments were rather forceful, as a company spokesman felt compelled to admit to "past deficiencies." Nevertheless, Reaction Motors asserted that its latest proposals were firm and expressed complete confidence in the company's ability to meet the revised schedules.<sup>41</sup>

The Propulsion Laboratory and the project office, after evaluating Reaction Motors' program, reported their recommendations to General Haugen on February 17, and to Lieutenant General



S. E. Anderson, ARDC commander, Major General R. P. Swofford Jr., director of research and development in Air Force headquarters, and General Wray on February 21. The recommendations included the continuation of Reaction Motors' program, the use of an XLR11 rocket engine for initial X-15 flights, the approval of overtime, the assignment of a top Defense Department priority (DX rating) to the project, increased effort by Reaction Motors, the establishment of a technical advisory group, and the start of a backup engine development program. The use of the XLR11 engine and an increase in effort by Reaction Motors were approved. Additional funds to cover the increased effort were also approved, as was the establishment of an advisory group. The top priority was denied (although the request eventually led to an improved priority)<sup>42</sup> and it was decided to postpone a decision on the possibility of using an alternate engine.\*

The most immediate result of the recommendations was the establishment of the technical advisory group which first met at Reaction Motors' plant on February 24, 1958. The group consisted of representatives from the NACA, the Bureau of Aeronautics, ARDC's weapon system group, and WADC. It was immediately apparent that the injectors and the thrust chamber presented the greatest development difficulties and that these were the areas in which the advisory group could render the greatest assistance to Reaction Motors.<sup>43</sup>

That measures taken as a result of the February meetings were not completely satisfactory to all of the parties concerned was quite evident. A summary of the NASA-ARDC position dated February 20, 1958 and retained in the files of the X-15 project

---

\*There was a clear distinction between proposals for an interim engine to permit flight trials before an XLR99 became available, and an alternate engine, to substitute for the XLR99 in the final X-15.

office stated that there was "only a remote possibility of getting any engine for the 1960 flight period." The same document contained an estimate that the value of the X-15 equipped with the XLR11 engines would "diminish to almost zero by start of 1960 flight period." The frustration produced by the engine situation at that time was evidenced by another statement--that even at this late date North American and Aerojet were better prospects to complete satisfactory engine developments before Reaction Motors, but not before the 1961 flight period.<sup>44</sup>

Despite severe criticism of the contractor, continued development of Reaction Motors' engine offered the only practical source, so project monitors decided that the contract should be continued.<sup>45</sup>

Of the three types of assistance offered to Reaction Motors (a government technical supervisory group, a government advisory group, and participation by other rocket engine contractors), the multi-contractor effort appeared to promise the greatest success. A government supervisory group was ruled out because of a lack of manpower. An advisory group was thought desirable for purposes of keeping Reaction Motors' progress under close surveillance, but fear was expressed that such a group would not be capable of providing the desired improvement in the company's efforts. The assistance of other engine contractors seemed to promise the greatest benefits, so the February conferees recommended that the possibility of obtaining such assistance be explored.<sup>46</sup>

During March, the Air Force opened negotiations with the Rocketdyne Division of North American Aviation in an effort to secure alternate injectors and an alternate thrust chamber.<sup>47</sup> North American was reluctant to undertake the development and it was not until General Wray and General Haugen arranged a personal conference with North American's vice president, Mr. Lee Atwood,

that Rocketdyne agreed to render general assistance to Reaction Motors and to undertake the development of injectors and a thrust chamber that could serve as alternates for the items that were giving Reaction Motors so much difficulty.<sup>48</sup>

Once North American's reluctance had been overcome, Rocketdyne immediately began tests of an S-4 injector and chamber from an XLR105-NA-1 (Atlas sustainer) engine, in an effort to adapt them to the Reaction Motors' engine.<sup>49</sup>

In addition to the numerous meetings held in February and March and the important decisions emanating from them, an additional factor of some importance influenced the development of the XLR99, and while this factor apparently did not materially alter the course of events, it could not help but add to the confusion that already existed. The additional factor was the absorption of Reaction Motors by the Thiokol Chemical Corporation. Negotiations for the proposed combination were conducted throughout the early part of 1958. The anticipated reorganization and pruning undoubtedly created a state of mind that was not conducive to the best efforts of Reaction Motors' management.<sup>50</sup>

The absorption of Reaction Motors by Thiokol was not completed until April 17, 1958, when stockholders of Reaction Motors approved the merger. Reaction Motors was subsequently renamed and became the Reaction Motors Division of the Thiokol Chemical Corporation.<sup>51</sup>

The decision to turn to Rocketdyne for assistance apparently spurred Reaction Motors' efforts toward the development of a "backup" design, for by the end of April, the Air Force felt it necessary to point out that the funds available were not sufficient to permit the development of both a Rocketdyne and a Reaction design. Reaction Motors was urged to subcontract with Rocketdyne

for further developments of the XLR105 chamber. The president of Reaction Motors agreed to a study to determine whether his own company's approach or Rocketdyne's offered the most promise. The results of the study were presented at a meeting held on May 27 at WADC. Reaction Motors, Rocketdyne, and NASA representatives, as well as Air Force personnel, attended the meeting and reviewed the alternate proposals. It appeared that Reaction Motors' alternate design (a concentric shell thrust chamber) would not solve the problem of chamber burnout, and that the design could not be translated into hardware in time to meet the schedules for the X-15 engine. As Reaction Motors' proposals were considered unsuitable, it was decided that the company should not pursue the concentric shell chamber further. On the other hand, Rocketdyne's proposals seemed to offer some hope of success, so the conferees agreed to continue the development of that firm's design.<sup>52</sup>

The decisions reached at the May 27, 1958 meeting were officially transmitted to Reaction Motors two days later. The letter specifically instructed Reaction Motors to subcontract for the development of the Rocketdyne designs. The same letter warned Reaction Motors that a "demonstration of thrust chamber performance and satisfactory progress in all other areas must be apparent by mid-July."<sup>53</sup>

Complying with instructions, Reaction Motors provided \$500,000 to fund Rocketdyne's program from May 28 until mid-July; the firm also made arrangements for continued development after that date. Rocketdyne's chamber development cost estimate was \$1,746,756, with an additional \$811,244 for the delivery of 14 research and development chambers and a further \$657,300 for 14 flight chambers.<sup>54</sup>

While the increased efforts by Reaction Motors appeared to be having some favorable effect on the progress of the XLR99, and

Rocketdyne's supplementary efforts got off to a promising start, the Air Force was not convinced that everything was proceeding as rapidly as possible. The Propulsion Laboratory, in an effort to stimulate Reaction Motors to even greater efforts, undertook the preparation of two letters. The first, dated June 17, 1958, was from General Wray to General Anderson. Its tenor was not obscure:

For sometime General Haugen and I have been concerned by the poor progress made by Reaction Motors Division on the development of the XLR99 rocket engine for the X-15 airplane program.

This engine was one that had been recommended . . . on the strength of a supposed advanced state of development of the LR30 rocket engine . . . .

. . . in spite of this state of development, Reaction Motors Division has experienced continual schedule slippage and financial overruns . . . .

It is by their own admission as well as the conclusions of our project engineers a fact that Reaction Motors Division has used poor judgement and management during the early stages of the engine development program.

Inability to meet performance and original Preliminary Flight Rating Test initiation date, which was a contractor deficiency, has resulted in submission of supplemental proposals. This by acceptance or rejection has placed the Air Force in the undesirable position of making program decisions which we would have preferred the contractor, through better management, to have made at a much earlier date.

General Wray also advised that a decision as to whether Rocketdyne's or Reaction Motors' chamber and injector designs should be continued was scheduled for July.<sup>55</sup>

The second letter, prepared by the Propulsion Laboratory, was enclosed with the first and was directed to Mr. J. W. Crosby, president of the Thiokol Chemical Corporation. General Wray felt that this second letter would have a greater impact if it went forward over General Anderson's signature. General Anderson's

staff shortened the four-page draft letter to two pages which, suitably signed, went to Mr. Crosby on June 27. The general tone of the revision was somewhat milder than the original, but the statements that "the results of the next few weeks . . . development effort will be extremely crucial in determining the direction of this engine procurement" and "I recognize the possible impact which pending Air Force decisions may have on Reaction Motors Division" could have left little doubt as to its meaning.<sup>56</sup> The Air Force had quite lost patience with Reaction Motors. The implication of contract cancellation was not difficult to derive.

Mr. Crosby replied to General Anderson's letter on July 3, 1958 with the admission that a "decision to take this development work away from Reaction Motor(s) Division would have a serious effect on the organization." He defended Reaction Motors' conduct of the program by emphasizing that the safety and reliability requirements of an engine intended for a manned aircraft had created unusually difficult development problems. He also offered to arrange a presentation of the current status of the XLR99 program for General Anderson.<sup>57</sup>

As it happened, progress at Reaction Motors began to improve while General Anderson and Mr. Crosby were exchanging letters and, as a consequence, no presentation was made. In a letter of August 1, 1958, General Anderson thanked Mr. Crosby for his reply of July 3 and declined the offered presentation.<sup>58</sup>

The threat that the engine delays would seriously impair the value of the X-15 program had generated a whole series of actions during the first half of 1958: personal visits by general officers to the contractor's plant, numerous conferences between the contractor and representatives of the government agencies involved in the program, increased support from the WADC Propulsion Laboratory and NASA, an increase in funds, an increase in effort

within Reaction Motors' plant, the composition of letters containing severe censure of the company's conduct of the program, and the introduction of another contractor (Rocketdyne). Whether any of these actions, or even the threat of XLR99 cancellation implied in General Anderson's letter of June, had any real effect on the program was difficult to determine. An emergency situation had been encountered, emergency remedies were used, and by midsummer improvements began to be noted.

Reaction Motors accumulated more engine test time in the first two weeks of July than during the entire program prior to that date. Performance was somewhat low but was high enough to offer reasonable encouragement that the specification performance could be met.<sup>59</sup> By August 7, 1958, performance had been raised to within two and one-half percent of specifications. By August, it was also apparent that the Rocketdyne proposal, rather enthusiastically endorsed by the North American project group was rather optimistic. By that time, Reaction Motors' subcontract with Rocketdyne had cost \$3,125,000, which the Propulsion Laboratory felt was "particularly unreasonable since the Rocketdyne program was initiated on the basis that little development effort would be required." The Rocketdyne chamber had failed to start on two attempts and a review of Rocketdyne's progress indicated a six to twelve month delay in the delivery schedule. The improvement at Reaction Motors and the lack of success at Rocketdyne led the Propulsion Laboratory in August 1958 to ask for the termination of the Rocketdyne program "as soon as possible."<sup>60</sup>

North American and Rocketdyne officials were notified of the Air Force's intention to terminate the backup program during a visit of Generals Wray and Haugen to the contractor's Inglewood plant. Major Arthur Murray, the X-15 project officer, took the opportunity of the visit to express his opinion that Rocketdyne's failure to achieve a suitable backup chamber within the sixty days

and for the few hundred thousand dollars originally contemplated came because "no amount of optimism or salesmanship could change the total effort required to develop advanced equipment."<sup>61</sup>

On August 15, 1958, another management meeting was held at Reaction Motors. Among those in attendance were General Haugen, Brigadier General W. A. Davis of the Air Materiel Command, Mr. Soule of NASA, and representatives from Air Force headquarters, ARDC and WADC. After evaluating the status of the XLR99 and of Rocketdyne's thrust chamber, the participants decided that the engine design should be frozen immediately and that it should incorporate Reaction Motors' chamber for purposes of the Preliminary Flight Rating Test. The Air Force and NASA urged Reaction Motors to continue its efforts to reach specification performance by minor changes of the injector design, but not at the expense of reliability or of further delaying the development schedule. A final decision on the continuation of the Rocketdyne program was postponed until October.<sup>62</sup>

During September, the progress of Reaction Motors continued to be encouraging as engine and injectors were subjected to increased testing. The Rocketdyne program continued to lag, primarily because of difficulties in mating Reaction Motors' ignition system to the Rocketdyne chamber. By the end of the month, the X-15 project office was convinced that the Rocketdyne program was not going to be a success, calling it an "expensive and apparently fruitless" effort.<sup>63</sup>

On October 7, the Technical Advisory Group met at Reaction Motors Division for a review of Reaction Motors' and Rocketdyne's progress. The review convinced the group that, while Rocketdyne's program might eventually lead to a higher performance engine, Reaction Motors' program would provide an acceptable engine at an earlier date. As a result of the group's recommendations and



subsequent discussions at WADC, the Propulsion Laboratory recommended (on October 10, 1958) termination of Rocketdyne's development program. Headquarters of WADC and the X-15 project office agreed to the termination shortly thereafter.<sup>64</sup>

Engine progress continued to be reasonably satisfactory during the remainder of 1958. A destructive failure that occurred on October 24 was traced to components that had already been recognized as inadequate and that were in the process of being redesigned. The failure, therefore, was not considered of major importance.<sup>65</sup>

By the end of November, the X-15 project office could report that an engineering inspection on November 18 and a Technical Advisory Group meeting the same day had revealed promising progress.<sup>66</sup>

Although the emergency actions of 1958 appeared to have produced a considerable improvement in the engine development program, all of the difficulties had not been resolved. At a Technical Advisory Group meeting of January 20, 1959, it became apparent that there were still some minor system leakage problems; that injector tests were still producing failures, particularly under low thrust and idle conditions; and that excessive heating was being encountered during idle. On January 23, a fuel manifold failed because of excessive vibration. Reaction Motors also reported encountering difficulties in obtaining satisfactory delivery from its suppliers.<sup>67</sup>

On February 12 and 13, the project office and the Propulsion Laboratory made two presentations at WADC, one to brief General Wray on the current status of the XLR99 program, and the second to a number of the contractor's management personnel--including the president of Reaction Motors Division. The purpose

of the second presentation was to re-emphasize the "Air Force's concern over the problems and delays which have been encountered." One result of the presentations was a decision to send several of WADC's technical personnel to the contractor's plant to investigate instrumentation, vibration, materials, and fluid flow. The Air Force hoped that the investigation of these problem areas would assist the contractor in overcoming the difficulties being encountered. The new group made its initial visit during the last week of February and the first week of March.<sup>68</sup>

A long-sought goal was finally reached on April 18, 1959 with completion of acceptance tests of the first Preliminary Flight Rating Test (PFRT) engine. The flight rating program began at once.<sup>69</sup>

At the end of April, representatives of ARDC, WADC, AMC and Reaction Motors met at the contractor's plant to decide on a "realistic" schedule for the remainder of the program. They agreed that the performance flight rating test should be completed by September 1, 1959. The first engine equipped with the final flight-type injector was to be ready for running in the latter part of May, the first ground test engine was to be delivered to Edwards Air Force Base by the end of May, and the first flight engine was to be delivered by the end of July. The conferees also decided that an additional engine should be subjected to the flight rating program in order to test a 30-second idle feature which had not been included in the original test engine.<sup>70</sup>

At the time these decisions emerged, it was quite impossible to determine whether the "realistic" schedule could actually be achieved, but delays in the overall X-15 test program, imposed by other factors, had reduced the air of urgency which surrounded the engine program throughout 1958. Some of the factors contributing to the less-than-perfect record of engine development were obvious.

Others were relatively obscure. Early in 1959 the X-15 project officer, Major Murray, summarized some of the development difficulties, and their causes. He stated quite bluntly that prior to the stimulus provided by the Russian satellite achievements of late 1957, there had been inadequate support for programs that did not lead directly to weapons. In his view, this lack of R&D support was not the result of the policies of individuals or even of commands, but was an inherent Air Force-wide phenomenon that was only overcome by the existence of a few "crusaders" at all levels and by the intensive efforts of those directly concerned with the individual projects. Major Murray considered that the original development schedule had been tight, that the funds had only been marginally sufficient at some stages in the program, and that personnel shortages, particularly a propulsion-expert vacancy within the project office, had all contributed to the contractor's repeated failures to meet the proposed development schedules. He also pointed out that the entire project was in advance of the state-of-the-art and that there was a tendency on the part of scientists engaged in such projects to postpone any commitment to a final design because of recurrent hopes of finding something just a little bit better.<sup>71</sup> (This latter problem--leading to the cynical expression "best is the enemy of better"--is one that still afflicts both the scientific and technical communities).

## NOTES

1. DF, Phillips to Dir/Labs., 5 Aug. 1954; memo., J. W. Rogers to Ch., Non-Rotating Engine Br., 11 Aug. 1954; DF, Keating to Ch., New Dev. Office, 15 Nov. 1954; ltr., Col. C. F. Damberg, Ch., Ac. Div., AMC, to Bell, et al., 2 Feb. 1955, subj.: Project 1226 Competition.
2. DF, Keating to Ch., New Dev. Office, 15 Nov. 1954.
3. Ibid.
4. Ibid.
5. Ltr., Damberg to Bell, 30 Dec. 1954.
6. Ltr., Turner to Cmdr., AMC, 3 Feb. 1955.
7. Ibid.
8. Ltr., Walker to RMI, 4 Feb. 1955.
9. Ltr., Lt. Col. W. K. Ashby, Ch., Power Plant Br., Aero. Equip. Div., AMC, to RMI, 24 Feb. 1955, subj.: Power Plant for New Research Airplane.
10. Ltr., Trenholm to Bell, et al., 22 Mar. 1955.
11. Ibid.
12. Ltr., Nay to Cmdr., WADC, 26 Apr. 1955.
13. Suborder, Trenholm to Ch., Rocket Sect., 20 June 1955.
14. Rpt., "Evaluation of Engines - Project 1226," 15 July 1955, Power Plant Lab., WADC.
15. Ltr., Lt. H. J. Savage, Non-Rotating Engine Br., Power Plant Lab., WADC, to RMI, 26 Oct. 1955, subj.: Engine for the X-15 Airplane.
16. DF, McCollough to Ch., Non-Rotating Engine Br., 1 Dec. 1955.
17. Ltr., R. W. Walker, Ch., Power Plant Dev. Sect., Power Plant Br., Aero. Equip. Div., AMC, to RMI, 8 Dec. 1955, subj.: Request for Proposal X-15 Aircraft Engine Development.
18. Ibid.
19. DF, T. J. Keating, Ch., Non-Rotating Engine Br., Power Plant Lab., WADC, to Proj. Officer, New Dev. Office, Ftr. Ac. Div., Dir/Sys. Mgmt, ARDC, 15 Dec. 1955, subj.: The X-15 Airplane Engine.

20. DF, J. W. Rogers, Liquid Propellant and Rocket Br., Rocket Propulsion Div., Power Plant Lab., WADC, to Ch., New Dev. Office, Ftr. Ac. Div., Dir/Sys. Mgmt., ARDC, 23 Dec. 1955, subj.: Methods of Contracting for X-15 Engine.
21. Ltr., Rear Adm. W. A. Schoech, Asst. Ch/R&D, BuAer, USN., to C/S, USAF, 28 Nov. 1955, subj.: Cognizance over development of rocket power plant for NACA X-15 research airplane.
22. Ltr., Col. D. H. Heaton, Ch., Aero. Div., Dir/R&D, DCS/D, USAF, to Cmdr., ARDC, 9 Dec. 1955, subj.: Cognizance Over Development of Rocket Power Plant for NACA X-15 Research Airplane.
23. TT Conf. between personnel of Dir/Sys. Mgmt. and Hq., ARDC, 29 Dec. 1955, subj.: BuAer Letter on the XLR30.
24. Ltr. (1st Ind.), Col. E. N. Ljunggren, Asst/Ac. Sys., ARDC, to Dir/R&D, USAF, 3 Jan. 1956, subj.: Cognizance Over Development of Rocket Power Plant for NACA X-15 Research Airplane.
25. Ltr., Brig. Gen. V. R. Haugen, Dep. Cmdr/Dev., WADC, to NACA-Wash., 15 Feb. 1956, subj.: Engine Contract for the X-15.
26. Ibid.
27. Ltr., W. P. Turner, Mgr. Customer Relations and Contr. Div., RMI, to Cmdr., AMC, 7 Feb. 1956, subj.: Rocket Engine System for X-15 Research Aircraft.
28. Ibid.
29. Ltr., Haugen to NACA-Wash., 15 Feb. 1956.
30. Ltr. Contr. AF33(600)-32248, 14 Feb. 1956, in AMC contr. files.
31. Memo., J. L. Sloop, Ch., Rocket Br., Lewis Lab., to Hq., NACA, 16 Apr. 1956, subj.: Visit to Reaction Motors, Inc. re: Powerplant for the X-15.
32. Ltr., H. P. Barfield, Asst. Ch., Non-Rotating Engine Br., Power Plant Lab., WADC, to RMI, 1 Aug. 1956, subj.: Contract AF33(600)-32248.
33. Ltr., A. G. Thatcher, Mgr., Div. Eng., RMI, to Cmdr., WADC, 17 Aug. 1956, subj.: Contract AF33(600)-32248.
34. Ltr., R. H. Rice, Vice Pres. and Gen. Mgr., NAA, to Asst. Dep. Cmdr/Weap. Sys., ARDC, 1 Feb. 1957, no subj.
35. Ltr., Maj. Gen. H. M. Estes Jr., Asst. Dep. Cmdr/Weap. Sys., ARDC, to NAA, 7 Mar. 1957, no subj.

36. Rpt., H. A. Soule, Res. Airplane Proj. Leader, to Members, NACA Res. Airplane Proj. Panel, 19 Mar. 1957, subj.: Project 1226-Progress report for months of January and February 1957.
37. Interview, Capt. K. E. Weiss, XLR99 Proj. Officer, Propulsion Lab., 23 Sept. 1958, by D. R. McVeigh, Hist. Br., WADC.
38. ARDC Form 111 (Mgmt. Rpt.), Proj. 3116, 29 Mar. 1957, subj.: X-15 Propulsion Subsystem.
39. Memo., A. W. Vogeley, Aero. Res. Engr., to Res. Airplane Proj. Leader, NACA, 3 Aug. 1957, subj.: X-15 Airplane - Discussions at Air Research and Development Command, Detachment #1, Wright-Patterson Air Force Base, Dayton, Ohio, on July 29-30, 1957.
40. Rpt., Status of XLR99-RM-1, 9 Jan. 1958 through 27 June 1958, prep. by Propulsion Lab., WADC, (hereafter cited as Status Rpt., 9 Jan-27 June 1958).
41. X-15 WSP0 WAR, 29 Jan. 1958.
42. Interview, C. E. McCollough, Asst. Ch., X-15 WSP0, Dir/Sys. Mgmt., ARDC, 14 May 1959, by R. S. Houston, Hist. Br., WADC.
43. Status rpt., 9 Jan-27 June 1958.
44. Memo., "NACA-ARDC Position 20th February 1958," unsigned and undated.
45. Status rpt., 9 Jan-27 June 1958.
46. Ibid.
47. Ltr., Maj. Gen. S. T. Wray, Cmdr., WADC, to Cmdr., ARDC, 17 June 1958, no subj.
48. Ibid.
49. Status rpt., 9 Jan-27 June 1958.
50. Ltr., Lt. Col. L. Schaffer, ARDC Regional Office, New York, N.Y., to Cmdr., ARDC, 7 Mar. 1958, subj.: Management Changes at Reaction Motors, Inc., Denville, N. J.
51. Porter, John Sherman, Ed., Moody's Industrial Manual for 1958, New York: D. F. Shea, Publisher.
52. Status rpt., 9 Jan-27 June 1958.
53. Ltr., F. W. Tangeman, Dep. Ch., Power Plant Dev. Sect., Power Plant Br., AMC, to Reactions Motors Div., Thiokol Chem. Corp.

(hereafter cited as RMD), 29 May 1958, subj.: Contract AF33(600)-32248, XLR99-RM-1 Back-up Chamber Development.

54. Status rpt., 9 Jan-27 June 1958.

55. Ltr., Wray to Cmdr., ARDC, 17 June 1958.

56. Ltr., Lt. Gen. S. E. Anderson, Cmdr., ARDC, to Pres., Thiokol Chem. Corp., 27 June 1958, no subj.; ltr. (draft), Cmdr., ARDC, to Thiokol Chem. Corp., approx. 17 June 1958, no. subj., (utilized in composition of ltr. of 27 June 1958 but not actually sent to addressee).

57. Ltr., J. W. Crosby, Pres., Thiokol Chem. Corp., to Cmdr., ARDC, 3 July 1958, no subj.

58. Ltr., Lt. Gen. S. E. Anderson, Cmdr., ARDC, to Pres., Thiokol Chem. Corp., 1 Aug. 1958, no subj.

59. "Red Flag Rpt., X-15 Powerplant XLR99-RM-1," D. McKee, Non-Rotating Engine Br., Propulsion Lab., WADC, 18 July 1958.

60. "Red Flag Rpt., Engine Testing of the XLR-99," prep. in Non-Rotating Engine Br., Propulsion Lab., WADC, 7 Aug. 1958; interview, Maj. A. Murray, Ch., X-15 WSPO, Dir/Sys. Mgmt., ARDC, 18 July 1959, by R. S. Houston, Hist. Br., WADC (hereafter cited as Murray interview).

61. See note above.

62. DF, Col. J. M. Silk, Ch., Propulsion Lab., to Cmdr., WADC, 20 Aug. 1958, subj.: XLR99 Engine for X-15 Aircraft.

63. X-15 WSPO WAR, 5 Sept. 1958, 13 Sept. 1958, 19 Sept. 1958, and 26 Sept. 1958.

64. X-15 WSPO WAR, 3 Oct. 1958, 10 Oct. 1958, 17 Oct. 1958, and 24 Oct. 1958.

65. X-15 WSPO WAR, 31 Oct. 1958, and 14 Nov. 1958.

66. X-15 WSPO WAR, 28 Nov. 1958.

67. X-15 WSPO WAR, 30 Jan. 1959.

68. X-15 WSPO WAR, 20 Feb. 1959, and 6 Mar. 1959.

69. X-15 WSPO WAR, 24 Apr. 1959.

70. X-15 WSPO WAR, 8 May 1959.

71. DF, Col. F. A. Holm, Dep/Advanced Sys., Dir/Sys. Mgmt., to Ch., Programs and Evaluations Office, IG, ARDC, 13 Feb. 1958, subj.: Survey of the X-15 Research Aircraft, 30 September-7 October 1958.



## CHAPTER IV

### ON-BOARD SYSTEMS

It might seem that a kind fate, after imposing the burdens involved in the development of the XLR99, would have permitted other phases of the X-15 program to proceed without hindrance. None of the other phases did present the problems posed by the engine, but difficulties continued to occur.

In early 1958, at the very height of the furor over the problems connected with the XLR99, a note of warning sounded for the auxiliary power unit (APU). North American had subcontracted the development of this important piece of equipment to the General Electric Company. On March 26, 1958 and again on April 11, 1958, General Electric notified North American of inability to meet the original specifications in the time available, and requested approval of new specifications. North American, with the concurrence of the X-15 project office, agreed to modify the requirements. The major changes involved an increase in weight from 40 to 48 pounds, an increase in start time from five to seven seconds, and a revision of the specific fuel consumption curves. In an effort to keep the fuel requirement as low as possible, North American asked General Electric to investigate the possibility of creating a derated auxiliary power unit. North American advised the project office that such a unit would reduce fuel consumption from 101 pounds per mission to 96 pounds and that the unit would still be capable of meeting the expected loads. General Electric was also fearful that an excessive amount of nitrogen might be necessary to overcome difficulties in cooling the upper turbine bearing of the power unit.<sup>1</sup>

In late March and early May, Propulsion Laboratory and weapon system project office representatives visited the General Electric facilities at Malta, New York, and Lynn, Massachusetts, to review the auxiliary power unit development. The group found that testing was proceeding at a satisfactory pace, that the heating of the upper turbine bearing had been reduced by a change in one of the unit's seals, but that little progress had been made in reducing the amount of nitrogen required for cooling the unit. Nitrogen flow was running as much as 80 percent over that required by specifications. Although no tests had yet been performed, General Electric reported progress in the development of the derated unit requested by North American.<sup>2</sup>

Actual tests of the derated unit began shortly after, and proved very encouraging. Bearing temperatures were held to about 300 degrees Fahrenheit with a nitrogen flow of only 12 pounds per hour. The predicted fuel economy of the derated unit was also established.<sup>3</sup> General Electric continued to alter the design in order to improve the cooling characteristics. A new inlet which permitted the introduction of the cooling nitrogen directly into the most troublesome bearing area alleviated the problem and reduced the nitrogen flow. Improvement was so substantial that the first production units were scheduled for shipment to North American in June.<sup>4</sup>

Some difficulties continued to arise in the course of the testing which was carried on in the summer of 1958, but most of them proved amenable to correction or were traced to malfunctions of the testing equipment rather than to the unit itself. Starting times at low temperatures remained excessive, prompting investigations of the advisability of increasing the wattage of the

hydrogen peroxide heater and of adding a wetting agent.<sup>5\*</sup> The heater capacity was increased but the decision on the use of a wetting agent was postponed.<sup>6</sup>

By the end of the summer of 1958, the auxiliary power unit seemed to have reached a more satisfactory state of development, an alternate machining method had effectively corrected undesirable stresses that had caused a turbine shaft failure, and satisfactory production units were ready for shipment.<sup>7</sup> The records of the project office thereafter failed to reveal any further concern with the auxiliary power unit until after the first captive flight in 1959. Those flights, unfortunately, did reveal some additional bearing problems and actually produced bearing failures. But investigation showed that the inflight failures had occurred because captive testing subjected the units to an abnormal operational sequence that would not be encountered during glide and powered flight.<sup>8</sup>

During the course of the X-15 program, project personnel from time to time had some concern for the development of an escape system and a pressure suit. Of the many accessory tasks included in the X-15 program, these caused the most concern, probably because they seemed to offer the greatest threat to the total development schedule.

Although full-pressure suits had been studied during World War II, attempts to fabricate a practical garment had met with failure. The Air Force took renewed interest in pressure suits in 1954, for by then it had become obvious that the increasing performance of aircraft was going to necessitate such a garment. The first result

---

\*A wetting agent is any substance added to a liquid in order to increase the dispersion and penetrability of the liquid. In this case, it was hoped that starting times could be reduced by increasing the contact between the hydrogen peroxide and the catalyst.

of the renewed interest was the creation of a suit that was heavy, bulky and unwieldy. The garment had only limited mobility and various joints created painful pressure points. It was not until 1955 that the David Clark Company, utilizing a distorted-angle fabric, succeeded in producing a garment that held some promise of ultimate success.<sup>9</sup>

As the Aero Medical Laboratory had met with only partial success in the design of a full-pressure suit at the time of the X-15 evaluation, there followed a certain amount of indecision as to the type of garment to be selected for the X-15 program. North American evidently had more confidence in the potential of full pressure suits than did the Air Force; in any event, the Plans Office of the Directorate of Research advised the Aero Medical Laboratory on August 23, 1955 that "the possibility and problems of utilizing a full-pressure suit" required further study. The same office felt that North American would require guidance in the field of pressure suits and that the Aero Medical Laboratory should determine whether a partial-pressure suit would be adequate for an aircraft with the proposed performance of the X-15.<sup>10</sup>

Despite the reluctance of the Air Force to commit all effort to a full-pressure suit, North American's detail specifications of March 2, 1956 called for just such a garment--to be furnished by the contractor.<sup>11</sup> The company continued to proceed as though the matter had been entirely settled, issuing an equipment specification for an omni-environmental, full-pressure suit on April 8, 1956.<sup>12</sup> That the matter was not entirely settled, however, was evidenced by the fact that on May 4, 1956 the Aero Medical Laboratory advised the project office to forward details of partial-pressure suit equipment to North American for "engineering of installation of subject provisions in the X-15 aircraft."<sup>13</sup>

A positive step toward Air Force acceptance of a full pressure suit occurred during a conference held at North American's plant on

June 20-22, 1956. A full-pressure suit developed by the Navy demonstrated during an inspection of the preliminary cockpit mockup, and although the Navy suit still had a number of deficiencies, the project office concluded that "the state-of-the-art on full pressure suits should permit the development of such a suit satisfactory for use in the X-15."<sup>14</sup>

On July 12, 1956, during a conference on the personal equipment of the X-15, representatives of the Aero Medical Laboratory reviewed the status of the laboratory's pressure suit development and indicated that the laboratory was willing to make any modifications necessitated by the requirements of the X-15 program. Mr. Crossfield, representing North American at the conference, had previously advocated a full-pressure suit and had taken the position that such a suit should be procured by his company rather than by the government. The reconciliation of divergent viewpoints at this pressure-suit conference influenced all subsequent government-contractor relationships, as the project officer was frequently faced with the necessity of reconciling the conflicting design philosophies of divergent personalities. The Aero Medical Laboratory's presentation at the conference convinced Crossfield that the laboratory could provide an adequate suit for the X-15 program. He insisted that the garment be designed specifically for the X-15 and that every effort be made to meet the laboratory's estimate schedule which called for an operational suit in the latter half of 1957. North American decided to take full advantage of the Aero Medical Laboratory's full-pressure suit, the laboratory agreed to work in close conjunction with the company in order to insure the suit would be suitable for the X-15, and the X-15 office accepted responsibility for providing funds to assist the laboratory's development program. Crossfield conceded that he could not commit North American to the change from a contractor-furnished item to a government-furnished suit, but he added that he

was in personal agreement with such a change and would so advise his company.<sup>15\*</sup>

While the conference of July 12 settled the question of a full-pressure garment as opposed to a partial-pressure suit and committed the Aero Medical Laboratory to the task of developing and supplying such a suit, the decision was not formalized for several months. North American's engineering change proposal which called for a government-furnished full pressure suit in lieu of contractor-furnished equipment was not issued until October 4, 1956, and it was not until January 16, 1957 that the AMC Directorate of Procurement and Production authorized the Air Force Plant Representative at North American to proceed with an official change in the contract.<sup>16</sup> North American's formal contract change request was not made until February 8, 1957.<sup>17</sup>

Although an "operational" suit had been promised for the latter half of 1957, progress was not as rapid as had been contemplated at the meeting in July 1956. The Aero Medical Laboratory did not have an opportunity to conduct major tests until the week of October 14-18, 1957, and those were of the first prototype suit.<sup>18</sup>

The Aero Medical Laboratory specifications which described the X-15 suit in terms approximating its final configuration, was not issued until January 1, 1958.<sup>19</sup> On April 10, 1958, the laboratory advised the X-15 project office that the first suit, scheduled for Crossfield's use would be delivered on June 1, 1958. At the same time, the laboratory advised that the four suits scheduled for delivery during the summer were the only suits programmed in

---

\*Crossfield's interest was not at all impersonal. He had joined North American for the purpose of becoming the first pilot of the X-15.

support of the X-15 project in fiscal year 1958. The laboratory was to receive other full-pressure suits, but the additional suits had been designed for service testing in operational aircraft and were not compatible with the X-15 cockpit. Aero Medical Laboratory specialists cautioned the project group that "funding for further X-15 suit procurement . . . during FY-58 must of necessity be furnished by your office."<sup>20</sup>

The X-15 project office, faced with a scarcity of suits and funds, began to investigate the possibility of using a seat kit rather than a back kit for the X-15 suit. Such a change would permit the suits designed for service testing to be utilized by the X-15 pilots, would enable the pilots to try the suits in operational aircraft, and would eliminate the need to furnish each X-15 pilot with two suits--one for familiarization in operational aircraft and one for flight in the X-15.<sup>21</sup>

The benefits to be derived from a program to make the X-15 and service test suits compatible would undoubtedly have been substantial, if such a program had been in effect from the beginning of the project. By May of 1958, however, the difficulties of obtaining compatibility outweighed the benefits. The X-15 project office continued to devote some thought to eventual compatibility, and the Aero Medical Laboratory actually carried out some preliminary design studies that were directed toward attainment of that goal. But despite these efforts, the suit utilized in the flight testing of 1959 was one that had been designed specifically for the X-15 and it was not suitable for use in operational aircraft.<sup>22</sup>

On May 3, 1958, representatives of the Aero Medical Laboratory and North American met at the David Clark Company, Worcester, Massachusetts and decided to freeze the configuration of the X-15 suit.<sup>23</sup> The decision proved to be somewhat premature, however.

Three months later, project personnel and contractor representatives, meeting\* at the Aero Medical Laboratory, discovered that the final configuration of the suit was still indefinite and could not be "frozen" until more data were on hand. The suit schedule had already been delayed about a month and it was apparent that further tests would be needed at once.

The lag in the suit schedule, and the possibility that there would be still further delays before adequate solutions were found for the remaining problems, created a new threat to the X-15 schedule. On August 19, 1958, the X-15 project office informed Colonel J. P. Stapp, the newly assigned chief of the Aero Medical Laboratory, that failure to produce an acceptable full pressure suit could result in a serious delay of the X-15 program. The project office suggested that a complete suit, including helmet and controller assembly, should be tested immediately. Colonel Stapp was also asked to press for a decision on a final configuration for the entire suit. Simultaneously, Colonel Stapp learned that the August 8 meeting had revealed a controversy in regard to the use of a face seal versus a neck seal in the suit assembly. He was asked to arrange tests of both types and to determine which was superior. The Aero Medical Laboratory was also asked to furnish a delivery schedule for the completed suits.<sup>24</sup>

A meeting between the chiefs of the X-15 project office and the Aero Medical Laboratory, at the end of August, resulted in an agreement that a full discussion of the pressure suit program would take place on September 8, 1958.<sup>25</sup> The September meeting, in turn, produced agreement that a fully qualified pressure suit was essential to the X-15 program and that the Aero Medical Laboratory

---

\*Attendees included representatives of the Aero Medical Laboratory, the X-15 project office, the WADC Crew Station Office, North American, the David Clark Company, the Firewel Company, and the Bill Jack Company.



was responsible for meeting this requirement. The first suit would be needed by January 1, 1959, a second suit would be needed by February 15, 1959, and four additional suits had to be ready by May 15, 1959. A suit with a neck seal and with provision for electrical defogging (of the faceplate) was to be the basic configuration, but a suit incorporating a face seal was to be considered as a backup because that configuration was nearer to qualification testing. Both configurations were to be tested, and both were to be procured in a quantity which would insure delivery of the first two suits on schedule--no matter what configuration proved superior. Ordering the components for the four suits scheduled for May was to be postponed until one of the two configurations had been proved superior. All of the pilots were to be furnished suits without the defogging provisions as quickly as possible, such suits being necessary for evaluation and familiarization flights.<sup>26</sup> Three such suits were delivered by the first week in November.<sup>27</sup>

Although at that point agreement and mutual understanding seemed to have encompassed all participants, such was not entirely the case. An Air Force inspection team that visited WADC as September became October to consider the X-15 project, found much to concern it in the pressure suit area. Inspectors reported the existence of "a serious disagreement between the North American Aviation Corporation and the Aero Medical Laboratory regarding certain design philosophies of the MC-2 suit assembly."<sup>28</sup> The reported disagreement was on the subject of a neck-seal versus a face-seal (actually an independently functioning oral-nasal mask inside the pressurized helmet), the Aero Medical Laboratory favoring the former and North American the latter. North American felt that the face seal could serve as an oxygen mask when the helmet face plate was raised and held that the pilot should be able to open his helmet. As the X-15 cockpit was pressurized by nitrogen, a pilot employing a suit with a neck-seal would be unable

to raise the face plate, no matter what the emergency. Both North American and the X-15 project office had given some thought to pressurizing the cockpit with oxygen but this had not been done. At the time of the team's visit to Wright Air Development Center, the electrical defogging provisions for the face plate were not fully satisfactory and the plate itself had not yet been subjected to air blast tests. Still another area of disagreement had arisen over the laboratory's use of a fluid-filled ear cup in the helmet. North American advised the inspection team that the seal had failed during centrifuge tests and that a more satisfactory cup was needed.

In summary, the team listed inadequate testing of the regulator components, unqualified defogging provisions, the lack of a blast-tested face plate, and the continuing controversy over the type of seal to be employed, as the major deficiencies of the pressure suit program.<sup>29</sup>

Fortunately, pressure suit difficulties finally began to yield to the combined pressures of the project office, the Aero Medical Laboratory and the various contractors. The prototype helmet with electrical defogging provisions was delivered on November 17, 1958, and although the helmet was not completely satisfactory from an optical standpoint, it did pass the defogging tests. On December 22, the helmet visor successfully withstood the wind blast tests, and by January 16, 1959, the Aero Medical Laboratory could report that the visor was "fully qualified."<sup>30</sup>

Scott Crossfield, the North American pilot who was scheduled to make the first X-15 flights, received a new suit of the face-seal type on December 17 and, two days later, the suit successfully passed nitrogen contamination tests at the Aero Medical Laboratory. On January 30, 1959, the project office reported that the Aero Medical Laboratory had furnished general qualification and test

information on a complete suit. The X-15 project officer attributed much of the credit for the successful and timely qualification of the full-pressure suit to the early and intensive efforts of Mr. Crossfield.<sup>31</sup>

Apparently another minor crisis had been met and overcome. After the first captive flights there were complaints about the poor optical qualities of the helmet and the first months of 1959 witnessed attempts to find a snap-on visor that would provide a temporary "fix."<sup>32</sup>

While not directly related to the pressure suit difficulties that threatened the over-all X-15 schedule, providing a means for successful escape from the aircraft, if that should become necessary, caused some concern during development. The type of escape system to be used in the X-15 had been the subject of debate at an early stage of the program; the decision to utilize the stable-seat, full-pressure-suit combination had been a compromise based largely on the fact that the ejection seat was lighter and offered fewer complications than the other alternatives.

As early as February 8, 1955, the Aero Medical Laboratory had recommended a capsular escape system, but the laboratory had also admitted that such a system would probably require extensive development. The second choice was a stable seat that incorporated limb retention features and one that would produce a minimum of deceleration.<sup>33</sup>

During meetings held in October and November of 1955, it was agreed that North American would design an ejection seat for the X-15 and would also prepare a study justifying the use of such a system in preference to a capsule. North American was to incorporate head and limb restraints in the proposed seat.<sup>34</sup>

Despite North American's plans to proceed with an ejection seat design, the Air Force was not convinced that such a seat was the best solution. At a specification meeting held at Wright Air Development Center on May 2-3, 1956, representatives of the X-15 project office and the Aero Medical Laboratory again pointed out the limitations of ejection seats. In the opinion of an NACA engineer who attended the meeting, the Air Force was still strongly in favor of a capsule--partly because of the additional safety a capsule system would offer and partly because the use of such a system in the X-15 would provide an opportunity for further developmental research. Despite this apparent preference for a capsule, the several participants finally agreed that because of the "time factor, weight, ignorance about proper capsule design, and the safety features being built into the airplane structure itself, the X-15 was probably its own best capsule." About the only result of the reluctance of the Air Force to endorse an ejection seat was another request that North American document the arguments for the seat.<sup>35</sup>

By November 1956, North American's seat had completed a number of tests in the wind tunnel at Massachusetts Institute of Technology. The results were encouraging although the seat had a tendency to stabilize in one of several positions instead of in a single position.<sup>36</sup>

The death of Captain Milburn G. Apt in the crash of the Bell X-2 in September 1956 renewed apprehension as to the adequacy of the X-15's escape system. Brigadier General Marvin C. Demler, ARDC's deputy commander for research and development, directed WADC to determine the best escape system for the X-15 and to conduct the study on an expedited basis. Evidently General Demler did not anticipate that the study would have any immediate effect on the design in progress, however, as he stated that the results of the study were to be incorporated in any "future versions of the X-15."<sup>37</sup>

By early 1957, North American's seat development efforts had indicated that several benefits could be derived from a change in the seat catapult originally specified. The company pointed out that the substitution of a contractor-furnished ballistic type rocket (Talco Number 1057-2) for the government furnished type T-18 ejection seat originally specified would increase energy of the catapult from 35,000 to 45,000 pound-feet, reduce frictional losses during the period of guided travel, increase the low altitude escape ability, eliminate binding of the catapult tubes as the seat entered the airstream, eliminate the forward pitching moment of the original T-18 type, and extend the deceleration period because of forward thrust component in the ballistic rocket type.<sup>38</sup> These arguments carried the day; the Air Force approved the change proposed by North American and the seat was equipped with the ballistic type rocket.<sup>39</sup>

Sled tests of the ejection seat began early in 1958 at Edwards Air Force Base, California, with the preliminary tests concluded on April 22. During the fourth and final run of the preliminary tests, a shock wave generator catapult exploded, the malfunction being attributed to the high air loads at the beginning of the extension sequence. The accident occurred at Mach 1.26 and at a pressure of 2,192 pounds per square foot. The seat, suit, and test dummy were all damaged beyond repair.<sup>40</sup> During a static firing on April 24, the seat ejected successfully, but the post-ejection operation of the seat was a failure because a striker on the seat did not contact the striker plate on the seat frame.<sup>41</sup> A second static firing on May 14, 1958 was more satisfactory, but was not a complete success as the parachute and parachute lines wrapped around the seat.<sup>42</sup> Because of the high cost of sled runs, the X-15 project office advised North American to eliminate the planned incremental testing and to conduct the tests at just two pressure levels--125 pounds per square foot and 1,500 pounds per square foot. The X-15 office felt that successful tests at these two

levels would furnish adequate proof of seat reliability at intermediate pressures.<sup>43</sup>

The first sled run of the second test series took place on June 4, 1958. It was made at the 125-pounds-per-square-foot level and appeared satisfactory.<sup>44</sup> Three more sled runs were conducted in June and July. The fourth test, which took place on July 3, revealed serious instability and North American decided to discontinue further testing until the cause of the instability could be determined.<sup>45</sup> A detailed analysis of the fourth test revealed that the seat would have to be considerably modified, and by the latter part of September, consideration was being given to the utilization of a Convair "B" or "industry" seat. As test data was incomplete for both the X-15 seat and the Convair seat, the Aero Medical Laboratory and the Aircraft Laboratory undertook only a preliminary evaluation. A final decision was to be reached after further sled tests of both seats.<sup>46</sup>

North American's revised seat was ready for further tests and the postponed sled runs were resumed on November 21. The revised seat included a trailing-boom modification, but the shock-wave generator that had been a part of the original design had been eliminated because the previous sled and wind tunnel tests had shown it to be unnecessary.<sup>47</sup> The redesigned seat functioned properly during the test of November 21, but the failure of a number of test-sled rockets reduced the scheduled 1,500 pounds per square foot pressure to about 800 pounds per square foot.<sup>48</sup> Two sled runs conducted in December were also marred by the failure of some of the test-sled rockets.<sup>49</sup>

Sled tests scheduled for January 1959 were delayed because of the unavailability of seat rockets. As the X-15 was nearly ready for captive flight, the X-15 project office arranged for a meeting with Aircraft Laboratory personnel on January 12 and requested that

the laboratory approve the ejection seat for captive and glide flights, even though the sled tests had not been completed. The Aircraft Laboratory verbally approved the use of the seat for such flights but only within a range between Mach .377 and Mach .72, and with dynamic pressures limited to those between 195 and 715 pounds per square foot.<sup>50</sup> (The only test that was conducted during January was a failure because the right-hand boom and right-hand fin both failed to deploy, with the result that the seat was highly unstable throughout most of the trajectory. The leg restraints of the seat failed during this same test, but this failure was attributed to the instability induced by the boom and fin malfunctions. The parachute functioned properly but did not open until just before the dummy reached the ground, too late to prevent a considerable amount of damage to the dummy.)<sup>51</sup>

As a result of the January test, the booms were carefully rechecked and strengthened and the seat's gas system was pressure tested.<sup>52</sup> The final sled-test was conducted on March 3, 1959 with a dynamic pressure of about 1,600 pounds per square foot and at Mach 1.15; at conditions considerably in excess of requirements, it was by far the most successful test. The leg manacles broke during this test, but North American began an immediate program to correct this failure.<sup>53</sup>

Additional sled tests and a parachute jump program were proposed in April of 1959, but project personnel decided that further extensive testing was unnecessary. The possibility of parachute tests was not eliminated but neither was there any definite decision to conduct such tests.<sup>54</sup>

The third item in the X-15 program for which the Air Force retained direct responsibility (apart from the XLR99 rocket engine and the full-pressure suit) was the all-attitude inertial flight data system. Designers realized from the first that the X-15's

performance would necessitate a new means of determining altitude, speeds and aircraft attitude; the NACA had proposed a stable-platform inertial integrating and attitude system as a means of meeting these needs. Unfortunately, not much thought seemed to have been given to the exact requirements of such a system or to the source from which it might be obtained.

An NACA report of meetings held at Wright Air Development Center and at North American in the fall of 1956 indicated that Wright Air Development Center agreed to furnish a stable platform. The NACA representative apparently assumed that the center had already developed a suitable platform, as his report stated that the instrument appeared to be a newly developed Bendix platform weighing only 28 pounds and occupying only one-half a cubic foot.<sup>55</sup>

North American and the NACA were not as certain about the platform, for during a visit to North American's plant, Mr. Walter Williams, the chief of NACA's High Speed Flight Station, specifically asked that the question of who was to supply the stable platform be clarified.<sup>56</sup> It was not until May 24, 1956 that a meeting was held (at Langley) for the purpose of discussing the actual requirements for the proposed stable platform system. The May meeting was attended by representatives of North American Aviation, the NACA, the Eclipse-Pioneer Division of Bendix, and Wright Air Development Center. One of the center's representatives was Mr. M. L. Lipscomb of the Instrument Branch in the Flight Control Laboratory. Mr. Lipscomb was subsequently to play an important role in the selection and development of the system that was eventually procured. The attendance of Eclipse-Pioneer representatives indicated that Bendix was still being considered as the potential contractor. The consensus of those attending the meeting was that a suitable platform could be developed in twenty-four months. North American presented the weight and size



requirements for the system, and the NACA agreed that since the platform would provide research information, 40 pounds of the estimated 65 pound weight should be considered as a part of the allotted weight of the research instrumentation.<sup>57</sup>

During the summer of 1956, Eclipse-Pioneer failed to display any further interest in providing the desired equipment and the Flight Control Laboratory invited the Sperry Gyroscope Company to submit proposals for a stable platform system. By August, Sperry had prepared the requested proposal, and on October 4 Sperry personnel participated in a briefing at Wright Air Development Center.<sup>58</sup>

On December 26, 1956, Mr. Lipscomb asked the Air Materiel Command to start the procurement of eight all-attitude flight data systems. Two of the requested items were designated "B" type and were to be utilized for research; six were to be assigned to the X-15 program and were designated type "A." The systems were described in detail in an accompanying exhibit, dated December 12, 1956. The laboratory recommended that the contract be given to the Sperry Gyroscope Company, estimating the cost at \$1,030,000.<sup>59</sup> The request for a proposal from Sperry was not made until February 6, 1957.<sup>60</sup>

Sperry replied on the 20th of the same month, and by March 28 the Flight Control Laboratory had evaluated and approved Sperry's proposals. In the meantime, however, the Air Materiel Command, the Flight Control Laboratory, the X-15 Weapon System Project Office, and Sperry had become involved in a controversy over a number of details. Some of the points at issue were the total amount of the contract, the amount of the fixed fee, the contractor's cost criteria, and the provisions for travel in connection with the proposed contract. By April 11, 1957, the contract negotiations seemed to have reached a deadlock, and the Air Materiel Command

buyer notified the Flight Control Laboratory and the project office that he intended to solicit sources other than Sperry in an effort to secure the desired system at a reduced cost. The laboratory and the project office responded to this development by reiterating their reasons for considering Sperry to be the only contractor capable of producing the required system within the time period available. The laboratory's position was that Sperry was the only concern with experience in components, systems, and applications, and the project office emphasized that Sperry was the only supplier who could produce the equipment in time to meet the schedule of the X-15 program.<sup>61</sup>

The Air Materiel Command still refused to concede the validity of the justifications for considering Sperry as a sole source and it was evident that the patience of all the parties concerned was rapidly being exhausted when the entire controversy was brought to a head on April 22, 1957. On that date, General Haugen, then director of development at Wright Air Development Center, advised the Air Materiel Command that "sole source procurement from Sperry provides the only possibility of obtaining the specific equipment to meet the time schedule of the X-15 program." General Haugen added that the importance of the X-15 program justified an award of the contract to Sperry "at the earliest possible date."<sup>62</sup> General Haugen's intervention proved the needed catalyst, for while negotiations continued, they were conducted only with the Sperry Gyroscope Company and a contract was ready for final negotiation by April 26, 1957. The cost-plus-fixed-fee contract, completed on June 5, 1957, provided an estimated cost of \$1,213,518.06, with a fixed fee of \$85,000.<sup>63</sup>

By May 1958, the cost had risen to \$2,498,518, and in June a further increase brought the cost to \$2,741,375 and raised the fee to \$102,000. No further increases took place during 1958, but several were permitted in early 1959. By mid-April 1959, costs had

reached \$3,234,188.87 and the fixed fee had risen to \$119,888.56.<sup>64</sup>

By April 1958, the Flight Control Laboratory and the X-15 project office had concluded that the scheduled delivery of the first Sperry unit in December of that year would not permit adequate testing to be performed prior to the first flights of the X-15. Consequently the several participants decided to install an interim gyroscopic system in the first two aircraft and to install the completed system in the third.<sup>65</sup>

As the development of the stable-platform progressed, it became apparent that its weight had been seriously underestimated. The increase in weight was obvious by May 1958, when Sperry undertook a program of weight reduction which, unhappily, was not as successful as the Flight Control Laboratory and the project office had hoped. In August, the project office reported that the weight was then approximately 100 percent greater than had been originally anticipated.<sup>66</sup>

As a result of the concern over the weight increase, the laboratory requested that Sperry be asked to justify the weight increase.<sup>67</sup> On August 7, 1958, the Air Materiel Command advised Sperry of the laboratory's desire for additional information on the company's weight reduction program and for a justification of the weight increases that had taken place.<sup>68</sup> Sperry's reply revealed that with a shock mount which would meet the vibration specification, the weight of the system had increased to 185.25 pounds and that with a less satisfactory but possibly adequate shock mount, the weight would be 165.25 pounds. Sperry stated that the company had been fully aware of the weight problem throughout the program and that it had "designed and developed an optimum system considering the present state of the art." A number of detail changes that had been made in the effort to eliminate excess

weight were also itemized. These included the substitution of aluminum for stainless steel whenever possible, the reduction of the thickness of cases and covers, the development of the less satisfactory but lighter shock mount, and a careful reduction of component weights whenever such reduction proved feasible. Sperry also pointed out that it had been necessary to include power supplies in the final design. Finally, Sperry had compared the X-15 system to similar systems made by other concerns and felt that the Sperry equipment was "lighter, more accurate, and required less total aircraft volume" than any of the equipment to which it was compared.<sup>69</sup>

Apparently Sperry's letter of justification was satisfactory, because project people thereafter accepted the fact that the system was overweight and was going to remain overweight.

By the end of November 1958, the two major system components, the stabilizer and the computer, had completed the individual tests and were ready to be tested as a complete system during the following month. The ground test equipment was also nearing completion and was scheduled for year-end delivery. The first system completed its acceptance test in December; the system and ground test cart were shipped to Edwards Air Force Base in mid-January 1959.<sup>70</sup> During the spring of 1959, the original plans to utilize the carrier B-52 as a test vehicle for the stable platform system were changed and arrangements made to test the equipment in a KC-97 that was already in use as a test aircraft in connection with the B-58 program.<sup>71</sup> The first test flights in the KC-97 were carried out in late April.<sup>72</sup> By June, North American had made a successful test installation of the Sperry system in the third X-15 and the stable-platform program seemed to be moving toward a successful conclusion with no major obstacles or difficulties foreseen.<sup>73</sup>

## NOTES

1. X-15 WSP0 WAR, 2 May 1958.
2. X-15 WSP0 WAR, 21 May 1958.
3. X-15 WSP0 WAR, 29 May 1958.
4. X-15 WSP0 WAR, 11 June 1958.
5. X-15 WSP0 WAR, 25 June 1958.
6. Interview, Lt. J. S. Worley, X-15 WSP0, Dir/Sys. Mgmt., ARDC, 22 May 1959, by R. S. Houston, Hist. Br., WADC.
7. X-15 WSP0 WAR, 5 Sept. 1958.
8. Remarks, Maj. A. Murray, Ch., X-15 WSP0, Dir/Sys. Mgmt., ARDC, to Bureau of Budget personnel at WADC, 6 May 1959.
9. Res. Airplane Comm., Report on Conference on the Progress of the X-15 Project, compilation of the papers presented at the IAS Bldg., Los Angeles, Calif., 28-30 July 1958, in files of X-15 WSP0, p. 117 (hereafter cited as Report on Progress of the X-15 - 1958).
10. DF, F. Harris, Ch., Plans Office, Dir/Res., to Ch., Aero Med. Lab., WADC, 23 Aug. 1955, subj.: Planning for Support of X-15 Development.
11. Rpt., "Detail Specifications NA 55-447," revised 2 Mar. 1956, in files of X-15 WSP0.
12. NAA Spec. No. NA5-4077, 8 Apr. 1956, in files of X-15 WSP0.
13. DF, Lt. Col. K. F. Troup, Ch., Aircrew Effectiveness Br., Aero Med. Lab., WADC, to Ch., New Dev. WSP0, Ftr. Ac. Div., ARDC, 4 May 1956, in files of X-15 WSP0.
14. X-15 WSP0 WAR, 28 June 1956.
15. AMC Form 52 (Record of Verbal Coordination), 12 July 1956, subj.: Personal Equipment for X-15 Weapons System, in files of X-15 WSP0, Murray interview, 16 July 1959.
16. Ltr., R. L. Stanley, Dep. Ch., Ftr. Ac. Br., Ac. and Missiles Div., Dir/Proc. and Prod., AMC, to AFPR, NAA, 16 Jan. 1957, subj.: Contract AF33(600)-31693, X-15 Airplane - ECP's NA-X15-7, NA-X15-1, NA-X15-8, NA-X15-12.
17. Ltr., S. C. Hellman, Mgr., Contr. and Proposals, NAA, to Cmdr., AMC, 8 Feb. 1957, subj.: Contract AF33(600)-31693 (3 X-15) NA-240

Contractual Document - Request for Full Pressure Pilot's Suit-Change from CFE to GFAE, ECP NA-X-15-8.

18. X-15 WSPO WAR, 30 Oct. 1957.
19. Exhibit, "Full Pressure Suit Assembly," Physiology Br., Aero Med. Lab., WADC, 1 Jan. 1958.
20. DF, G. Kitzes, Asst. Ch., Physiology Br., Aero Med. Lab., WADC, to Ch., Ftr. Ac. Div., Dir/Sys. Mgmt., ARDC, 10 Apr. 1958, subj.: Status of MC-2 Full Pressure Altitude Suits for the X-15 research aircraft.
21. X-15 WSPO WAR, 2 May 1958.
22. Interview, Capt. J. E. Schaub, X-15 WSPO, Dir/Sys. Mgmt., ARDC, 28 May 1959, by R. S. Houston, Hist. Br., WADC.
23. X-15 WSPO WAR, 9 May 1958.
24. DF, Lt. J. E. Schaub, X-15 WSPO, Dir/Sys. Mgmt., ARDC, to Ch., Aero Med. Lab., WADC, 19 Aug. 1958, subj.: X-15 Full Pressure Suit Program.
25. X-15 WSPO WAR, 5 Sept. 1958.
26. X-15 WSPO WAR, 13 Sept. 1958.
27. X-15 WSPO WAR, 7 Nov. 1958.
28. Rpt., "Survey of the X-15 Research Aircraft, 30 September-7 October 1958," IG, ARDC, undated.
29. Ibid.
30. X-15 WSPO WAR, 21 Nov. 1958, 5 Dec. 1958, and 9 Jan. 1959; DF, Holm. to Ch., Programs and Evaluations Office, IG, ARDC, 13 Feb. 1958.
31. X-15 WSPO WAR, 30 Jan. 1959; Murray interview, 16 July 1959.
32. X-15 WSPO WAR, 3 Apr. 1959.
33. DF, H. E. Savely, Ch., Biophysics Br., Aero Med. Lab., WADC, to Ch., New Dev. Office, Ftr. Ac. Div., Dir/WSO, 8 Feb. 1955, subj.: Acceleration Tolerance and Emergency Escape.
34. Memo., Vogeley to Res. Airplane Proj. Leader, 30 Nov. 1955.
35. Memo., Soulé to Members, NACA Res. Airplane Proj. Panel, 7 June 1956.

36. Memo., H. A. Soule, Res. Airplane Proj. Leader, Langley Aero. Lab., to Members, NACA Res. Airplane Proj. Panel, NACA, 15 Nov. 1956, subj.: Project 1226 - Progress Report for months of September and October 1956.
37. Memo., Brig. Gen. M. C. Demler, Dep. Cmdr/R&D, to Dep. Cmdr/Weap. Sys., ARDC, 2 Jan. 1957, subj.: Escape Systems for Research Vehicles such as the X-15.
38. Ltr., R. H. Rice, Vice Pres. and Gen. Mgr., NAA, to Cmdr., AMC, 31 Jan. 1957, subj.: Contract AF 33(600)-31693, X-15 Airplane, GFAE Ejection Seat Catapult - Change to CFE Ballistic Rocket Type-ECP NA-X-15-19.
39. Interview, Lt. R. L. Panton, X-15 WSPO, Dir/Sys. Mgmt., ARDC, 1 June 1959, by R. S. Houston, Hist. Br., WADC.
40. X-15 WSPO WAR, 2 May 1958.
41. Ibid.
42. X-15 WSPO WAR, 21 May 1958.
43. Ibid.
44. X-15 WSPO WAR, 11 June 1958.
45. X-15 WSPO WAR, 11 July 1958.
46. X-15 WSPO WAR, 3 Oct. 1958.
47. X-15 WSPO WAR, 7 Nov. 1958, and 28 Nov. 1958.
48. X-15 WSPO WAR, 28 Nov. 1958.
49. X-15 WSPO WAR, 9 Jan. 1959.
50. X-15 WSPO WAR, 16 Jan. 1959.
51. X-15 WSPO WAR, 6 Feb. 1959.
52. X-15 WSPO WAR, 13 Feb. 1959.
53. X-15 WSPO WAR, 13 Mar. 1959.
54. X-15 WSPO WAR, 17 Apr. 1959.
55. Memo., Vogeley to Res. Airplane Proj. Leader, 30 Nov. 1955.
56. Memo., Williams to Res. Airplane Proj. Leader, 27 Jan. 1956.

57. Memo., Soule' to Members, NACA Res. Airplane Proj. Panel, 7 June 1956.
58. Proposal No. A. E. 1752, "Development of Flight Research Stabilized Platform," Sperry Gyroscope Co., Aug. 1956, in AMC Contr. files (AF33-600-35397); memo., Soule' to Members, NACA Res. Airplane Proj. Panel, 15 Nov. 1956.
59. DF, M. L. Lipscomb, Instr. Br., Flt. Control Lab., WADC, to Ch., Accessories Dev. Sect., Accessories Br., Aero. Equip. Div., AMC, 26 Dec. 1956, in AMC contr. files (AF33-600-35397).
60. Ltr., H. L. Kimball, Ch., Accessories Dev. Sect., Accessories Br., Aero. Equip. Div., AMC, to Sperry Gyroscope Co., 6 Feb. 1957, in AMC contr. files (AF33-600-35397).
61. Negotiation Summary, C. E. Deardorff, Accessories Dev. Sect., Accessories Br., Aero. Equip. Div., AMC, 25 Apr. 1956, in AMC contr. files (AF33-600-35397).
62. DF, Brig. Gen. V. R. Haugen, Dir/Dev., WADC, to Ch., Aero. Equip. Div., Dir/Proc. and Prod., AMC, 22 Apr. 1957, subj.: Flight Data System for the X-15; Purchase Request DE-7-S-4184, in AMC contr. files (AF33-600-35397).
63. Contr. AF33(600)-35397, 5 June 1957, in AMC contr. files.
64. Supp. Agmt. 1 through 10, Contr. AF33(600)-35397, 5 June 1957 and subsequent, in AMC contr. files.
65. X-15 WSPO WAR, 2 May 1958.
66. DF, W. W. Bailey, Programming Br., Flt. Control Lab., WADC and Chester E. McCollough, Asst. Ch., X-15 WSPO, to Ch., Flt. Data Sect., Accessories Br., Aero. Equip. Div., AMC, 5 Aug. 1958, in files of X-15 WSPO.
67. Ibid.
68. Ltr., J. J. Slamer, Dep. Ch., Flt. Data Sect., Accessories Br., Aero. Equip. Div., AMC, to AFPR, Sperry Rand Corp., 7 Aug. 1958, subj.: Ltr. Contract AF33(600)-35397, in AMC contr. files.
69. Ltr., G. W. Schleich, Aero. Equip. Div., Sperry Gyroscope Co., to Cmdr., AMC, 4 Sept. 1958, subj.: Contract AF33(600)-35397, in AMC contr. files.
70. X-15 WSPO WAR, 23 Jan. 1959.
71. X-15 WSPO WAR, 13 Mar. 1959.



72. X-15 WSPO WAR, 1 May 1959.

73. Interview, Lt. R. L. Panton, X-15 WSPO Dir/Sys. Mgmt., ARDC, 1 June 1959, by R. S. Houston, Hist. Br., WADC.



## CHAPTER V

### TYING UP LOOSE ENDS

Apart from the major problems encountered during the development of the X-15, there arose less critical items of concern, some technical, some administrative, and some financial. Portions of the program were routine, but even those portions demanded time and attention if they were to remain in the routine category. For instance, the ground range presented a problem that had no connection with the selection of radars, with geography, or with building and equipping the stations. The procurement of the high-altitude tracking equipment was expedited by transferring the procurement responsibility to Patrick Air Force Base and the equipment was obtained by the modification of an existing contract.<sup>1</sup> The detail design and fabrication of the range was undertaken by the Electronic Engineering Company of Los Angeles, California.<sup>2</sup> The range was completed and ready for operation in late 1958.<sup>3</sup> The difficulty in connection with the ground range stemmed from the joint nature of the program and consisted of a dispute between the Air Force and NACA over the operation of the range after its completion.

As early as April 7, 1955, Brigadier General B. S. Kelsey, the Air Force representative on the Research Airplane Committee, wrote to Dr. H. L. Dryden, director of NACA, and requested that an understanding be reached on the construction and operation of the range.<sup>4</sup> At a meeting of the Research Airplane Committee on May 17, 1955, the NACA agreed to cooperate with WADC and the Air Force Flight Test Center (AFFTC) in planning the range; the Air Force was to be given the task of building and equipping the range, and the NACA would operate the range after its completion.<sup>5</sup>

These decisions were not favorably received by Air Force Flight Test Center personnel, who felt that their center was "being relegated to the position of procurement agent for NACA." The Air Force also had some reservations about the "adequacy of equipment NACA had selected for the range."<sup>6</sup> Despite the flight test center's lack of enthusiasm for the arrangements, an amendment of the original development directive, issued on July 28, 1955, spelled out the flight test center's responsibility for establishing the range. As neither the amendment nor the original directive assigned the responsibility for the operation of the completed range, the Air Force Flight Test Center renewed its attempts to acquire this responsibility. On December 2, 1955, Lieutenant Colonel B. H. Harris Jr., deputy chief of staff for operations at the flight test center, wrote to the commander of ARDC and formally requested that his center "be assigned the responsibility for operating, as well as developing, the test range."<sup>7</sup>

The NACA, determined to retain the responsibility for the operation of the range, simply reminded the Air Force that the matter had been settled by an agreement between Dr. Dryden and General Kelsey. As the Air Force's strongest argument was that Air Force operation would permit the use of the range during tests of such advanced fighters as the F-107, the NACA quickly agreed to make the range available for such tests--providing such use did not interfere with the X-15 program.<sup>8</sup>

Fortunately this dispute over range operation and the similar disagreement with the Navy in relation to engine procurement were exceptions rather than the rule. The division of responsibility was usually arranged without difficulty and such disputes never offered a serious threat to the ultimate success of the project.

Another aspect of the X-15 program which occasionally caused concern was in the field of public relations. With numerous

government agencies and contractors taking part in a program which was certain to arouse a great deal of public interest, there was bound to be some conflict. Each agency and each contractor had an information service or a publicity department, and it was to be expected that each such organization would seek to insure proper recognition of its own parent. Ordinarily such competition would have been considered unimportant, but after the success of the Soviet satellites in late 1957, the X-15 program became intimately associated with national prestige. The successful launchings of space vehicles made everything connected with space exploration a matter of vital interest to a world that was deeply concerned about the technological race between the United States and the Soviet Union. The X-15 ceased to be just an advanced research airplane--it suddenly became an entry in an international race.

As the roll-out of the first X-15 did not occur until October 15, 1958, most of the early publicity burden was carried by the pilots who had been selected to fly the aircraft. At one stage, the demands upon these pilots became so serious as to interfere with their training and indoctrination program. Some of those involved actually reported physical incapacitation as a result of extensive travel, irregular meals, and a lack of proper rest.

In addition to actual interference with the X-15 schedule, the publicity efforts sometimes created ill will and misunderstandings. For instance, on January 13, 1958, the Office of Information Services in the Office of the Secretary of the Air Force issued a release which stated that after company demonstrations of the X-15, the airplane would be flown by Air Force pilots and then turned over to NASA.\* As an arrangement had already been made for the Air Force and NASA pilots to share in the research flights and for NASA

---

\*National Aeronautics and Space Administration, successor to NACA.

to plan and direct the flights, the release confused the NASA and Air Force personnel at Edwards who had been planning the joint research effort and the relegation of NASA to last place displeased that agency.<sup>9</sup>

One of the least comprehensible facets of the public relations program was the insistence that the X-15 would reach an altitude of 100 miles. The 100-mile figure was repeated in almost every article and broadcast that dealt with the X-15, and it was also used in speeches by Air Force and North American personnel. While it was more than probable that the X-15 would exceed its design altitude of 250,000 feet, the constant reiteration of a maximum altitude figure seemed very questionable public relations. The Air Force might find itself in the unenviable position of having to confess that the X-15 could not meet its advertised goals. On the other hand, if the design altitude had been used in the various releases, it is very possible the Air Force could have proudly announced that the X-15 had exceeded the goals that were set for it. The X-15 project office consistently reduced the altitude claims in its contacts with news media, but apparently the 100-mile figure was firmly established in the public mind. The inflated figure seemed particularly unnecessary in view of the fact that attainment of the design altitude would approximately double the existing record. If the X-15 failed to reach the goals announced in the pre-flight publicity releases, it could only result in a general impression that the project was a partial failure, or create doubts about the veracity of the information services that had persisted in publicizing the maximum performance.<sup>10</sup>

Throughout the development of the X-15 there was a considerable body of opinion favoring an extension of the program beyond the original three aircraft. Although this opinion did not prevail, the proposals for such an extension were of more than passing interest. At one point, North American suggested the X-15 be

utilized as a training vehicle and that an extensive training program be established. The company pointed out that such a program would prove useful in familiarizing Air Force pilots with rocket powered aircraft, the use of reaction controls, and some of the physical problems and sensations of space flight. Naturally such a training program would have necessitated production of additional X-15s.

Early in 1958, the NACA expressed the hope that at least one additional X-15 could be produced and that it would be devoted specifically to flight-control research.<sup>11</sup> However, the most serious consideration for an extension of the X-15 program came in mid-1958. On April 8 of that year, Air Force headquarters asked ARDC to consider the wisdom of investing additional funds in an expansion of the X-15 program. The letter in which the request appeared asked that ARDC weigh the cost of a possible extension against the probable value of such an extension and suggested that the requested recommendations should "include configuration changes, estimated costs, aircraft availability, the increased performance expected, the test results to be obtained and a brief substantiation of their value." It also urged that the results of the extension studies be made available to Air Force headquarters at an early date--because any decision for an extension would have to be made before North American broke up the engineering team that had been assembled for the original program.<sup>12</sup>

In response to this request for a study of extension possibilities, the X-15 project office conferred with the Directorate of Laboratories at WADC, with North American, and with the Air Force Flight Test Center at Edwards Air Force Base. Conferences with these groups took place between April 17 and 21, 1958 in an attempt to determine the future research requirements that might be met by an extension of the X-15 program. There were discussions on a possible change of structural materials of the

X-15 airframe and attempts to estimate preliminary costs, design changes, production schedules, and performance figures for some of the more promising modifications that were envisioned. By April 29, ARDC, the X-15 project office, and the Directorate of Laboratories had concluded that the best approach to an extension program would be to prove out the existing aerodynamic design and to consider the possibilities of improving performance by the use of new structural materials and the substitution of an improved rocket engine for the XLR99. The suggestion for a new engine was evidently influenced by the then-current difficulties with the XLR99; Air Force planners emphasized that any new engine should "be obtained as a result of across the board BMD (Ballistic Missile Division) and other effort, and not as a sole X-15 effort."<sup>13</sup>

On May 19-20, the Air Force obtained verbal concurrence on the proposed extension from the Navy and NASA. The recommendation submitted to ARDC by the X-15 project office on June 13 was that the X-15 program be extended by the construction of three additional airplanes employing structural materials capable of withstanding higher temperatures than the materials utilized in the original design. ARDC approved the recommendation and forwarded it to Air Force headquarters on June 16.<sup>14</sup>

The urgency expressed in the original headquarters letter of April 8 had apparently evaporated, for it was not until November 18, 1958 that General Demler, director of research and development at Air Force headquarters, advised the commander of ARDC that no further consideration was to be given to an extension of the X-15 program. The Research Airplane Committee had not even met until October 31 and at that time Dr. Dryden, the NASA representative, stated that NASA had reached the conclusion that the original aircraft were adequate for the research contemplated by his agency and that any increase in program effort should be directed toward the maximum exploitation of the three X-15s already



procured. He held that further development of additional aircraft was not warranted; the Navy and Air Force representatives on the Research Airplane Committee concurred with Dr. Dryden.<sup>15</sup>

Not everyone was convinced that the decision was final, as there was still some interest in at least one additional airplane for flight-control research. However, as all three of the original aircraft were substantially completed by early 1959, it seemed most unlikely that there would ever be any additional extension proposals.

Responsibilities of the X-15 project office were many and varied. The office had to maintain close liaison with NASA on such subjects as the spherical nose being developed under the supervision of that agency. It had to make the arrangements for procuring and modifying the two B-52s that were to replace the B-36 carrier that had been contemplated originally. Other aircraft had to be scheduled for pilot indoctrination and for chase planes. Ground equipment had to be scheduled so that components could be tested and the aircraft maintained. Pilots had to be selected for the program. It was necessary to arrange for wind tunnel and centrifuge time at facilities already operating on tight schedules. Difficulties in the fabrication of some of the pressure tanks had to be considered and decisions made as to whether it was better to accept the weight penalties involved in a change of materials or the time penalties involved in further development. The decision to switch from a B-36 to a B-52 carrier necessitated that the X-15 be carried under a wing rather than the fuselage of the carrier aircraft and this change introduced new problems of sonic fatigue and flutter that had to be met and overcome. Testing revealed that some components of the stability augmentation system were not satisfactory and time was lost in redesign and retesting. A second industry conference, held July 28-30, 1958 at Los Angeles, had to be arranged. In addition to all of these items, routine paper work

had to be accomplished, reports reviewed, and everyone concerned with the program advised of the progress. The paper work was more burdensome than usual because of the participation of two additional government agencies--the Navy and the NACA(NASA).

Two incidents, both connected with the XLR99 engine, revealed the variety of details with which the project office had to concern itself. They also illustrated the problems and frustrations that occurred when that office was not adequately or promptly informed. The first incident involved an aft-fuselage section which was furnished to Reaction Motors for the purpose of determining engine-airframe compatibility and the effects of engine vibration on the fuselage structure. When Reaction Motors had completed the tests, the company in accordance with existing procurement directives advised the nearest Air Force procurement office of this fact and asked for instructions as to its disposition. The Air Force office in question, without consulting the X-15 project office, instructed Reaction Motors to destroy the item and the company proceeded to do so, completely unaware that the \$300,000 airframe section had been scheduled for further use at Edwards.

The second incident involved the shipment of the first XLR99 engine, associated ground test equipment, and spare parts to Edwards Air Force Base. In an attempt to expedite the engine program, the project office had arranged for a military aircraft to transport the engine, the test equipment, and the spares from Reaction Motors to Edwards. Everything was ready for shipment when the Air Force inspector noted that the boxes containing the spare parts were not labeled in accordance with regulations. The part numbers had been inked rather than typed on the box labels. The inspector refused to release the spares for shipment, with the result that the military aircraft proceeded to California with the engine and test equipment but without any spares. Subsequently, the project office had to arrange for shipment of the spares by commercial air freight.<sup>16</sup>

In addition to the various technical tasks, the X-15 project office was under almost constant pressure to secure additional funds. This was because the original cost estimates for the X-15 and the XLR99 were grossly inaccurate. Initial "planning" figures--for everything--totalled \$12,000,000. Between October 1955 and the beginning of 1959, the airframe estimates rose from \$50,063,500 to \$64,021,146, and in the first 6 months of 1959 the estimates continued to rise, first to \$67,540,178, and then to \$68,657,644.<sup>17</sup> By June 1, 1959, North American's informal estimate of the airframe's cost had risen to \$74,500,000.<sup>18</sup>

The engine program involved even greater relative increases. In 1955, it had been estimated that the engine costs would ultimately be about \$6,000,000. By the time an engine contract had been signed, the estimate had risen to \$10,000,000. At the end of fiscal 1958, engine costs had risen to over \$38,000,000 and expenditures in fiscal year 1959 brought the cost to \$59,323,000. Estimated engine costs for fiscal 1960 were \$9,050,000--almost as much as the total estimate of 1955. As of June 1959, it appeared that engine costs would be at least \$68,373,000--over five times the original estimate for the entire X-15 program and almost a seven-fold increase over the costs contemplated when the engine contract was signed.<sup>19</sup> With the cost of the stable platform totalling more than \$3,000,000, and with an estimated \$6,000,000 needed for support costs in fiscal 1961, the total cost of the X-15 was going to exceed \$150,000,000, even if no further increases occurred. (The Navy's contribution to the X-15 program totalled \$6,400,000 at the end of fiscal 1959 and the project office hoped that an additional \$1,000,000 could be obtained from the Navy in fiscal 1960.)<sup>20</sup> All the remaining funds had to be furnished by the Air Force, as NASA's contribution was in the form of wind tunnel testing and evaluation. The program was never halted by a lack of funds, but there were occasions when the funds only became available at the last possible moment; the files of the project

office revealed that appeals for funds, justifications for additional funds, and the explanation of increased costs absorbed much of that office's time and energy.

Despite the technical problems, the paper work, the necessity of seeking more and more funds, and the recognition that the first flight would be several months late, the X-15 program did move ahead.

It was still too early to predict the ultimate success of the X-15 in its research role, but the development program was rapidly drawing to a close in 1959. The airplane took slightly longer to reach the flight stage than had originally been contemplated, and the costs were far in excess of the estimates, but it would appear that the vehicle would be able to equal or surpass the performance for which it had been designed, and that it would prove to be a valuable research instrument.

## NOTES

1. X-15 WSP0 WAR, 21 June 1956.
2. Report on Progress of the X-15 - 1956.
3. Report on Progress of the X-15 - 1958.
4. Ltr., Brig. Gen. B. S. Kelsey, Dep. Dir/R&D, DCS/D, USAF, to Dir/NACA, 7 Apr. 1955, no subj.
5. Ltr., Dryden to Dep. Dir/R&D, 20 May 1955.
6. Memo. for record, Maj. J. E. Downhill, Asst. Ch., Test Proj. Sect., Aer. & Propulsion Div., ARDC, 28 July 1955, subj.: Flight Test Range for the X-15.
7. Ltr., Lt. Col. B. H. Harris Jr., DCS/O, AFFTC, to Cmdr., ARDC 2 Dec. 1955, subj.: X-15 Research Aircraft.
8. Ltr., H. A. Soulé, Res. Airplane Proj. Leader, NACA-Langley, to NACA Liaison Officer, WPAFB, 20 Dec. 1955, subj.: Air Force-North American-NACA conference on Project 1226 Range.
9. Rpt., "Survey of the X-15 Research Aircraft, 30 September-7 October 1958," IG, ARDC, undated.
10. Remarks, Maj. A. Murray, Ch., X-15 WSP0, Dir/Sys. Mgmt., ARDC, to Bureau of Budget personnel at WADC, 6 May 1959; interview, C. E. McCollough, Asst. Ch., X-15 WSP0, Dir/Sys. Mgmt., ARDC, 11 June 1959, by R. S. Houston, Hist. Br., WADC.
11. Ltr., J. W. Crowley, Associate Dir/Res., NACA-Wash., to NACA High-Speed Flt. Station, Edwards AFB, Calif., 28 Feb. 1958, subj.: Flight control research for hypersonic airplanes.
12. X-15 WSP0 WAR, 23 Apr. 1958.
13. X-15 WSP0 WAR, 2 May 1958.
14. X-15 WSP0 WAR, 18 June 1958.
15. Ltr., Maj. Gen. M. C. Demler, Dir/R&D, USAF, to Cmdr., ARDC, 18 Nov. 1958, subj.: Further Development of X-15 Aircraft.
16. Interview, C. E. McCollough, Asst. Ch., X-15 WSP0, Dir/Sys. Mgmt., ARDC, 12 June 1959, by R. S. Houston, Hist. Br., WADC.
17. Cost Projection, Contr. AF33(600)-31693, prep. quarterly by NAA Dept. of Pricing, 1955-1959, in files of X-15 WSP0.

18. Interview, C. E. McCollough, Asst. Ch., X-15 WSP0, Dir/Sys. Mgmt., ARDC, 12 June 1959, by R. S. Houston, Hist. Br., WADC.

19. Ibid.

20. Ibid.

## CHAPTER VI

### RESEARCH AT THE EDGE OF SPACE

The first of the three X-15s (serial 56-6670) arrived at the Air Force Flight Test Center at Edwards Air Force Base, California, in mid-October 1958, trucked over the hills from the plant in Los Angeles for testing at the NASA High-Speed Flight Station (subsequently redesignated the NASA Flight Research Center). It was joined by the second airplane (serial 56-6671) in April 1959. In contrast to the relative secrecy that had attended flight trials with the XS-1 a decade before, the X-15 program offered the spectacle of pure theater.

The X-15's contractor program lasted two years, from mid-1959 through mid-1960. North American had to demonstrate the craft's general airworthiness during flights above Mach 2, and successful operation of its new XLR-99 engine before delivering the craft to NASA. Anything beyond Mach 3 was considered a part of the government's research obligation. The task of flying the X-15 during the contractor program rested in the capable hands of Scott Crossfield, who had left NACA to join North American and help shepherd the craft through its long development. Crossfield completed the first captive flight on March 10, 1959 and first glide flight on June 8. Just prior to landing, the plane began a series of increasingly wild pitching motions; thanks to Crossfield's instinctive corrective action, the plane landed safely; Crossfield feared for the plane's design, but fortunately, for naught. North American's engineers subsequently modified its boosted control system to increase the control rate response, and the X-15 never again experienced the porpoising motions that had threatened it on its first flight. On September 17, the X-15

completed its first powered flight, when Crossfield flew the second airplane to Mach 2.11.<sup>1</sup>

A series of ground and in-flight accidents marred the X-15's contractor program, fortunately without injuries or even greatly delaying the program. On November 5, 1959 an engine fire--always extremely hazardous in a volatile rocket airplane--forced an emergency landing on Rosamond Dry Lake; the X-15 landed with a heavy load of propellants and broke its back, grounding this particular X-15 for three months. During a ground engine test with the third X-15 (the first one equipped with the large Thiokol engine), a stuck pressure regulator caused the craft to explode, necessitating virtual rebuilding. The second X-15 was actually the first of the series to test-fly the large XLR-99 engine, and after adding the engine to the other two craft, North American delivered the last of the X-15s to NASA in June 1961. By that time, NASA, Air Force, and Navy test pilots had been operating the X-15 on government research flights for just over a year.<sup>2</sup> The research phase of the X-15's flight program involved four broad objectives: verification of predicted hypersonic aerodynamic behavior and hypersonic heating rates, study of the X-15's structural characteristics in an environment of high heating and high flight loads, investigation of hypersonic stability and control problems during atmospheric exit and reentry, and investigation of piloting tasks and pilot performance. By late 1961, these four areas had been generally examined, though detailed research continued to about 1964 using the first and third aircraft, and to 1967 with the second (the X-15A-2). Before the end of 1961, the X-15 had attained its Mach 6 design goal and had flown well above 200,000 feet; by the end of the next year the X-15 was routinely flying above 300,000 feet. Within a single year, the X-15 had extended the range of winged aircraft flight speeds from Mach 3.2 to Mach 6.04, the latter achieved by Air Force test pilot Bob White on November 9, 1961.



The intensive flight program on the X-15 revealed a number of interesting things. Physiologists discovered the heart rates of X-15 pilots varied between 145 and 180 beats per minute in flight, as compared to a normal of 70 to 80 beats per minute for test missions in other aircraft. Researchers eventually concluded that prelaunch anticipatory stress, rather than actual postlaunch physical stress, influenced the heart rate. They believed, correctly, that these rates could be considered as probable baselines for predicting the physiological behavior of future pilot-astronauts. Aerodynamic researchers found remarkable agreement between the tunnel tests of exceedingly small X-15 models and actual results, with the exception of drag measurements. Drag produced by the blunt aft end of the aircraft proved 15% higher on the actual aircraft than wind-tunnel tests had predicted. At Mach 6, the X-15 absorbed eight times the heating load it experienced at Mach 3, with the highest heating rates occurring in the frontal and lower surfaces of the aircraft, which received the brunt of airflow impact. During the first Mach 5+ excursion, four expansion slots in the leading edge of the wing generated turbulent vortices that increased heating rates to the point that the external skin behind the joints buckled. As a solution, technicians added small Inconel alloy strips over the slots, and the X-15 flew without further evidence of buckling. It offered "a classical example of the interaction among aerodynamic flow, thermodynamic properties of air, and elastic characteristics of structure."<sup>3</sup>

Heating and turbulent flow generated by the protruding cockpit enclosure posed other problems; on two occasions, the outer panels of the X-15's heavy glass cockpit windshields fractured because heating loads in the expanding frame overstressed the soda-lime glass. NASA solved the difficulty by changing the cockpit frame from Inconel to titanium, modifying its configuration, and replacing the outer glass panels with high-temperature alumina-silica glass. Another problem concerned an old aerodynamics and

structures bugaboo, panel flutter. Panels along the flanks of the X-15 fluttered at airspeeds above Mach 2.4, forcing engineers to add longitudinal metal stiffeners to the panels.\* All this warned aerospace designers to proceed cautiously. John Becker, writing in 1968, noted of the X-15 experience that:<sup>4</sup>

The really important lesson here is that what are minor and unimportant features of a subsonic or supersonic aircraft must be dealt with as prime design problems in a hypersonic airplane. This lesson was applied effectively in the precise design of a host of important details on the manned space vehicles.

A serious roll instability predicted for the airplane under certain reentry conditions posed a serious challenge to flight researchers. To simulate accurately the reentry profile of a returning winged spacecraft, the X-15 had to fly at angles of attack of at least 17°. Yet the cruciform "wedge" tail, so necessary for stability and control in other portions of the plane's flight regime, actually prevented it from being flown safely at angles of attack greater than 20° because of potential rolling problems. By this time, FRC researchers had gained enough experience with the XLR-99 engine to realize that fears of thrust misalignment--a major reason for the large vertical fin--were unwarranted. The obvious solution was simply to remove the lower half of the ventral fin, a portion of the fin that X-15 pilots had to jettison prior to landing anyway so that the craft could touch down on its landing skids. Removing the ventral produced an acceptable tradeoff. While it reduced stability by about 50% at high angles of attack, it greatly improved the pilot's ability to control the airplane. With the ventral off, the X-15 could now fly into the previously "uncontrollable" region above 20° angle of attack with complete safety. Eventually the X-15 went on to

---

\*Concerns over panel flutter resulted in extensive redesign of the proposed X-20 Dyna-Soar, and played a major part in the research rationale behind the ASSET program, as will be seen.

reentry trajectories of up to 26°, often with flight path angles of - 38° at speeds up to Mach 6, a much more demanding piloting task than the shallow entries flown by manned vehicles returning from orbital or lunar missions. Its reentry characteristics were remarkably similar to those of the later NASA Space Shuttle orbiter.<sup>5</sup> \*

When Project Mercury took to the air, it rapidly eclipsed the X-15 in glamour, but the two programs really were complementary in nature, though Mercury dominated some of the research areas that had first interested X-15 planners, such as "zero g" weightlessness studies. The use of reaction controls to maintain a vehicle's attitude in space proved academic after Mercury flew, but the X-15 had already proved them and would also furnish valuable design information on the use of blending reaction controls with conventional aerodynamic controls during an exit and reentry, a matter of concern to subsequent Shuttle development. The X-15 experience clearly demonstrated the ability of pilots to fly rocket-propelled aircraft out of the atmosphere and back in to precision landings. Flight Research Center director Paul Bikle saw the X-15 and Mercury as a:<sup>6</sup>

parallel, two-pronged approach to solving some of the problems of manned space flight. While Mercury was demonstrating man's capability to function effectively in space, the X-15 was demonstrating man's ability to control a high-performance vehicle in a near-space environment. . . .considerable new knowledge was obtained on the techniques and problems associated with lifting reentry.

Operationally, the X-15 gave its team a number of headaches. Because of the complexity of its systems, the plane experienced a

---

\*In fact, one way of envisioning the Space Shuttle is to imagine a transport the size of a McDonnell Douglas C-9 Nightingale (civilian DC-9), carrying the payload of a Lockheed C-130 Hercules, and flying like the X-15.

number of operational glitches that delayed flights, aborted them before launch, or forced abandonment of a mission after launch. Early in the program, the X-15's stability augmentation and inertial guidance systems were two major problem areas. NASA eventually replaced the Sperry inertial unit with a Honeywell unit first designed for the Dyna-Soar. The plane's propellant system had its own weaknesses. Pneumatic vent and relief valves and pressure regulators gave the greatest difficulties, followed by spring pressure switches in the auxiliary power units, the turbopump, and the gas generation system. NASA's mechanics routinely had to reject 24 to 30% of spare parts as unusable, a clear indication of the difficulties of devising industrial manufacturing and acceptance test procedures when building for use in an environment at the frontier of science.<sup>7</sup> Weather posed a critical factor. Many times Edwards enjoyed fine weather, the lakebed bone-dry, while upcountry the High Range was covered with clouds, alternate landing sites were flooded, or some other meteorological condition postponed a mission. In one case, weather and minor maintenance kept one X-15 grounded from mid-October 1961 to early January 1962. When it finally flew, the pilot had to make an emergency landing up range. Weather and maintenance then grounded the plane until mid-April.<sup>8</sup> On an average, the X-15 completed 1.77 flights per month--a figure comparing well with the shuttle's own subsequent experience (until the loss of Challenger).

The X-15 had its share of accidents, one of which killed an Air Force test pilot; another seriously injured a NASA research pilot. As previously mentioned, Scott Crossfield once made an emergency landing on Rosamond Lake with an X-15 damaged by an engine fire; the plane broke its back on landing, necessitating lengthy repairs. The third X-15 blew up during ground testing of its XLR-99 engine, but it, too, was rebuilt. In November 1962, an engine failure forced Jack McKay to make an emergency landing at Mud Lake, Nevada, in the second X-15; its landing gear collapsed and the X-15 flipped

over on its back. McKay was promptly rescued by an Air Force medical team standing by near the launch site, and eventually recovered to fly the X-15 again. But his injuries, more serious than at first thought, eventually forced his retirement from NASA. In November 1967, Mike Adams was killed in a strange accident in the third X-15 that will be discussed later in great detail. One of the most remarkable close calls in the X-15 program involved Air Force test pilot Major William J. "Pete" Knight. In June 1967 he experienced a complete electrical failure while climbing through 100,000 feet at Mach 4+. With no computed information and guidance, Knight continued to climb, suddenly reduced to "seat of the pants" flying technique. During reentry he managed to restart one of the auxiliary power units, restoring some instruments, and made an emergency landing at Mud Lake, for which he received the Distinguished Flying Cross.\* Within NACA and later NASA, developing the X-15 had been left largely in the hands of Langley, the center most closely involved in determining its mission and configuration, with important inputs from the other centers, especially the High-Speed Flight Station. The flight research program was the province of the Flight Research Center with liaison and support from the Air Force Flight Test Center at Edwards. In the summer of 1961, as the X-15 approached its maximum performance during test flights, a new initiative began, one that sprang jointly from the Air Force's Aeronautical Systems Division at Wright-Patterson AFB and from NASA Headquarters: using the X-15 as a "testbed" or carrier aircraft for a wide range of scientific experiments unforeseen in its original conception.

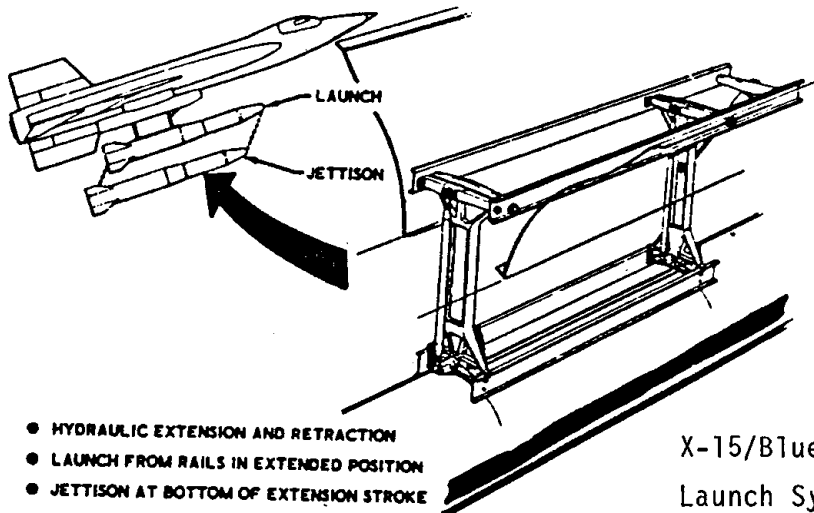
Pressures had existed even before the X-15 first flew to extend the scope of the program beyond aerodynamics and structural

---

\*Knight subsequently related his thoughts as he began his descent; looking down at Mud Lake he muttered, "Take a good look, Pete, that's probably where you'll plant it!" Such, fortunately, was not the case.

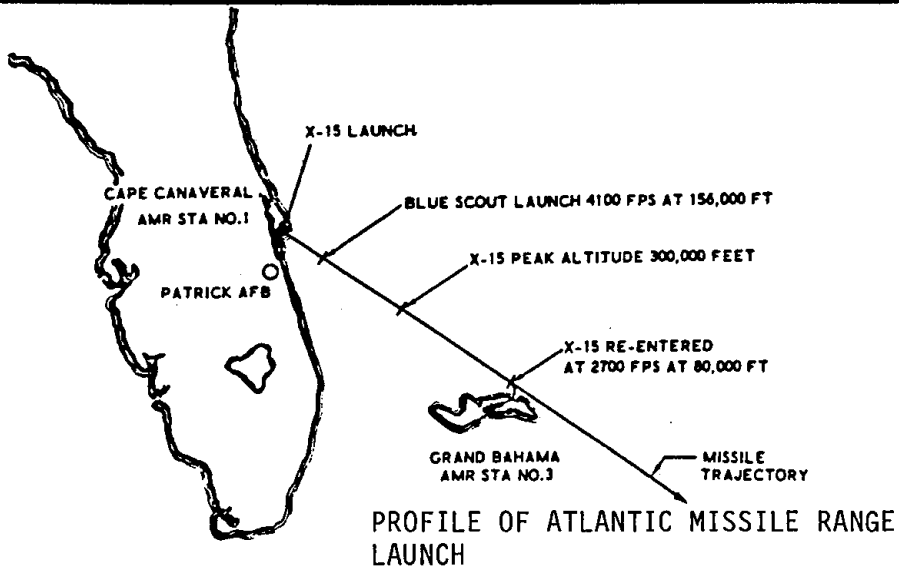
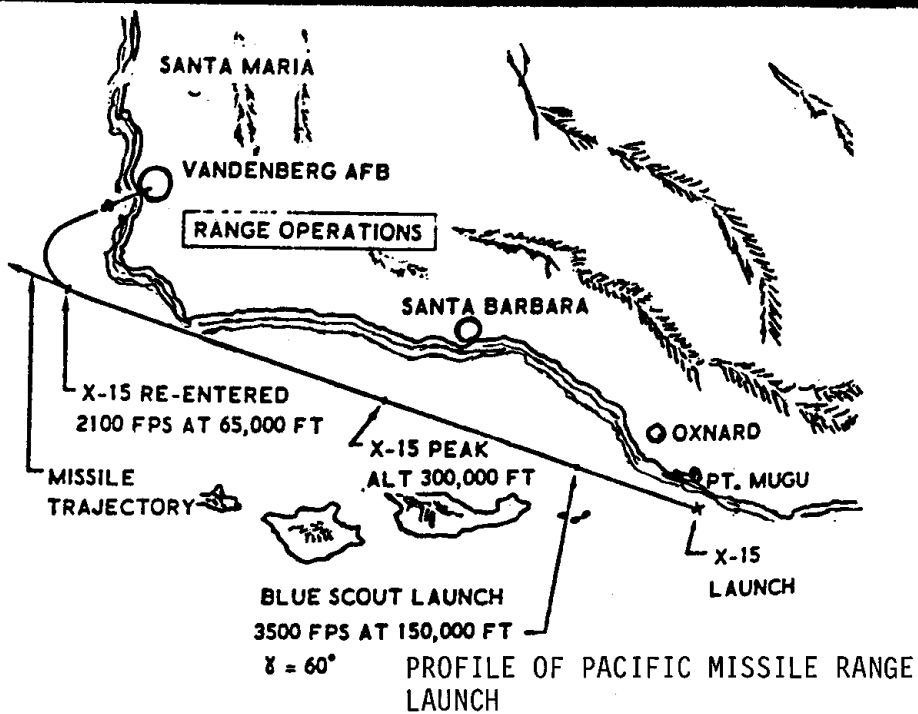
research. Researchers at the Flight Research Center had proposed using the airplane to carry to high altitude some experiments related to the proposed Orbiting Astronomical Observatory; others suggested modifying one of the planes to carry a Mach 5+ ramjet for advanced air-breathing propulsion studies. Over 40 experiments were suggested by the scientific community as suitable candidates for the X-15 to carry. In August 1961, after consulting with Bikle at FRC, NASA headquarters, and the Air Force Aeronautical Systems Division, NASA and the Air Force formed an X-15 Joint Program Coordinating Committee to prepare a plan for a follow-on experiments program. Most of the suggested experiments were in space science, such as ultraviolet stellar photography. Others supported the Apollo program and hypersonic ramjet studies. A series of meetings held at NASA headquarters over the fall of 1961 between the joint committee. Hartley Soulé, and John Stack, then NASA's director of aeronautical research, culminated in approval of the proposed follow-on research program and the classification of two groups of experiments. Category A experiments consisted of well-advanced and funded experiments having great importance; category B included worthwhile projects of less urgency or importance.<sup>9</sup>

In March 1962 the X-15 committee approved the "X-15 Follow-on Program," which NASA announced April 13 in a Headquarters news conference presided over by Stack and FRC planner Hubert Drake. Drake announced that the first task would be to fly an ultraviolet stellar photography experiment from the University of Wisconsin's Washburn Observatory. NASA had investigated the possibility of the X-15 carrying a Scout booster that could fire small satellites into orbit, the entire B-52/X-15/Scout becoming in effect a multistage satellite booster, but that the agency finally rejected the idea for reasons of safety, utility, and economy. The X-15's space science program eventually included twenty-eight experiments running from astronomy to micrometeorite collection, using wingtop



- HYDRAULIC EXTENSION AND RETRACTION
- LAUNCH FROM RAILS IN EXTENDED POSITION
- JETTISON AT BOTTOM OF EXTENSION STROKE

X-15/Blue Scout Launch System



Pods that opened at 150,000 feet, and high-altitude mapping. Two of the follow-on programs, a horizon definition experiment from the Massachusetts Institute of Technology and tests of proposed insulation for the Saturn launch vehicle, directly benefitted navigation equipment and the thermal protection used on Apollo-Saturn launch vehicle. FRC quickly implemented the follow-on program. In 1964, fully 65% of all data returned from the three X-15 aircraft involved follow-on projects; this percentage increased yearly through conclusion of the program.<sup>10</sup>

NASA's major X-15 follow-on project involved a Langley-developed Hypersonic Ramjet Experiment (HRE).<sup>\*</sup> FRC advanced planners had long wanted to extend the X-15's speed capabilities, perhaps even to Mach 8, by adding extra fuel in jettisonable drop tanks and some sort of thermal protection system. Langley researchers had developed a design configuration for a proposed hypersonic ramjet engine. The two groups now came together to advocate modifying one of the X-15s as a Mach 8 research craft that could be tested with a ramjet fueled by liquid hydrogen. The proposal became more attractive when the landing accident to the second X-15 in November 1962 forced the rebuilding of the aircraft. The opportunity to make the modifications was too good to pass up. In March 1963 the Air Force and NASA authorized North American to rebuild the airplane with a longer fuselage. Changes were to be made in the propellant system; two huge drop tanks and a small tank for liquid hydrogen within the plane were to be added; the drop tanks could be recovered via parachute and refurbished, as with the Space Shuttle's solid-fuel boosters nearly two decades later. Forty weeks and \$9 million later, North American delivered the modified plane, designated the X-15A-2, in February 1964.<sup>11</sup>

---

<sup>\*</sup>See the Hypersonic Ramjet Experiment case study for the "ground" story of this interesting effort.



The X-15A-2 (Figure 4) first flew in June 1964, piloted by Air Force test pilot Major Bob Rushworth. Early proving flights demonstrated that the plane retained satisfactory flying qualities at Mach 5+ speeds, though on three flights, thermal stresses caused portions of the landing gear to extend at Mach 4.3, generating "an awful bang and a yaw," but Rushworth landed safely despite (in one case) blow-out of the heat-weakened tires upon touchdown. In November 1966, Air Force pilot Pete Knight set an unofficial world's airspeed record of Mach 6.33 in the plane. NASA then grounded it for application of an ablative coating to enable it to exceed Mach 7.<sup>12</sup>

Flight Research Center's technical staff had evaluated several possible coatings that could be applied over the X-15's Inconel structure to enable it to withstand the added thermal loads experienced above Mach 6. NASA hoped that such coatings might point the way toward materials that could be readily and cheaply applied to reusable spacecraft, minimizing refurbishment costs and turn-around time between flights. Such a coating would have to be relatively light; have good insulating properties; be easy to apply, cure, and then remove; and be easy to reapply before another flight. On FRC's advice, a joint NASA--Air Force committee selected an ablator developed by the Martin Company, MA-25S, in connection with some corporate studies on reusable spacecraft concepts. Consisting of a resin base, a catalyst, and a glass bead powder, it would protect the X-15's structure from the expected 2000°F heating as the craft sped through the upper atmosphere. Martin estimated that the coating, ranging from .59 inches thick on the canopy, wings, vertical, and horizontal tail down to .015 inches on the trailing edges of the wings and tail, would keep the skin temperature down to a comfortable 600°F. The first unpleasant surprise came, however, with the application of the coating to the X-15A-2: it took six weeks. Because the ablator would char and emit a residue in flight, North American had installed an "eyelid"



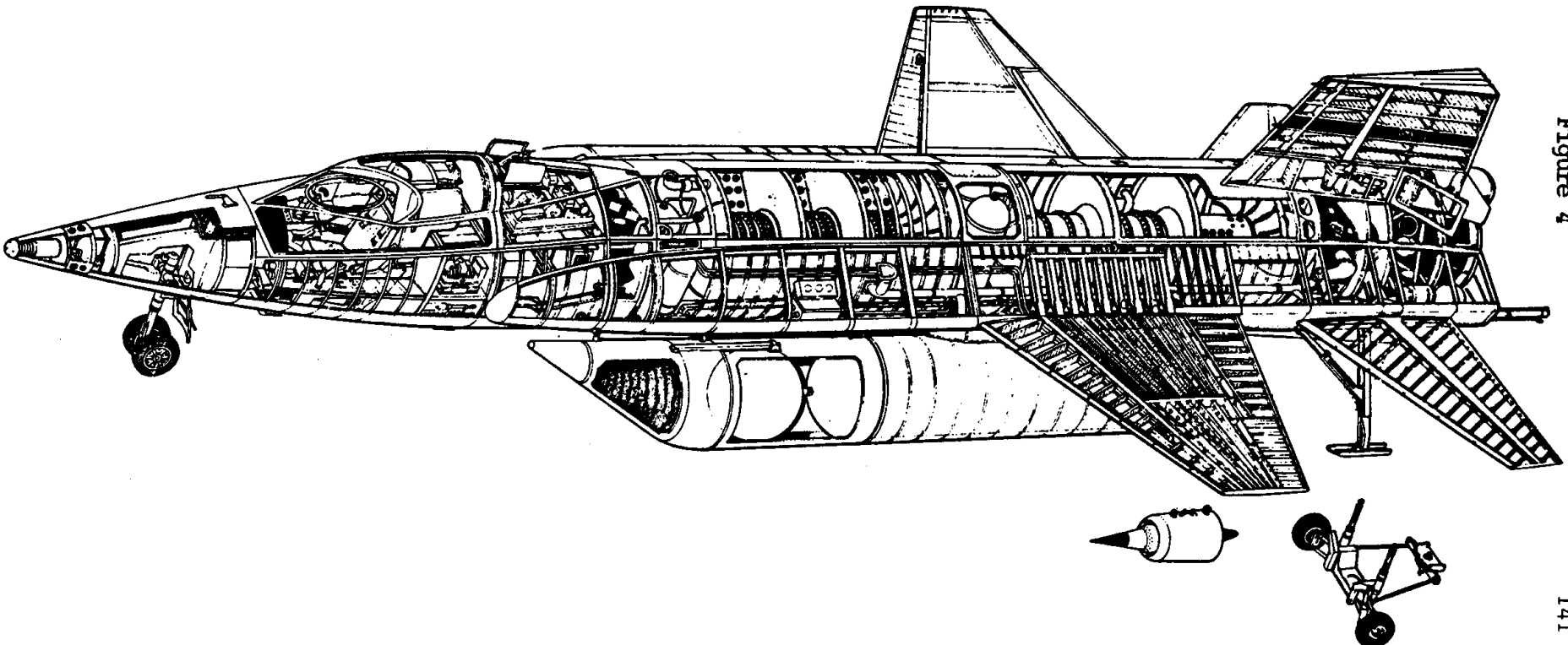


Figure 4

over the left cockpit window. It would remain closed until just before approach and landing. During launch and climbout, the pilot would use the right window, but residue from the ablator would render it opaque above Mach 6.<sup>13</sup>

Late in the summer of 1967, the X-15A-2 was ready for flight with the ablative coating. It had already flown with a dummy ramjet affixed to its stub ventral fin; the ramjet, while providing a pronounced nose-down trim change, actually added to the plane's directional stability. The weight of the ablative coating--125 pounds higher than planned--together with expected increased drag reduced the theoretical maximum performance of the airplane to Mach 7.4, still a significant advance over the Mach 6.3 previously attained with the plane. The appearance of the X-15A-2 was striking, an overall flat off-white finish, the huge external tanks a mix of silver and orange-red with broad striping. NASA hoped that early Mach 7+ trials would lead to tests with an actual "hot" ramjet rather than the dummy now attached to the plane. On August 21, 1967 Knight completed the first flight in the ablative-coated plane, reaching Mach 4.94 and familiarizing himself with its handling qualities. His next flight, on October 3, 1967, was destined to be the X-15's fastest flight and the most surprising as well.<sup>14</sup>

That day, high over Nevada, Knight dropped away from the B-52, the heavy X-15A-2 brimming with fuel. The following is an extract from the official AFFTC summary of the X-15A-2's envelope expansion program:<sup>15</sup>

The launch transients were very mild with a bank angle excursion of 14 degrees. During the rotation the pilot had good control of the aircraft and increased the angle of attack to 15 degrees and felt the onset of buffet. The remainder of the rotation to the planned pitch angle was made at 12 to 13 degrees angle of attack. During this period the roll control was excellent and the bank angle

did not deviate more than 8 degrees. The maximum dynamic pressure experienced during the rotation was 560 psf, close to the 540 psf observed on the simulator. The planned pitch angle of 35 degrees was reached in 38 seconds and was maintained within plus/minus one degree.

The external tanks were ejected 67.4 seconds after launch. Tank separation was satisfactory, however, the pilot felt the ejection was "harder" than the last one he had experienced (Flight No. 2-50-89). The longitudinal trim change to the aircraft was from 4.2 to -2 degrees angle of attack. The external tank recovery system performed satisfactorily and the tanks were recovered in repairable condition.

After tank ejection the planned 2 degree angle of attack was maintained within +1 degree. As the aircraft came level at an indicated altitude of 99,000 feet, the pilot increased the angle of attack to 6 degrees to maintain zero rate of climb. During this task the pilot reported that the pitch control was very sensitive and it was difficult to hold a constant angle of attack.

The pilot reported shutting down the engine at 6500 fps; however, the final radar data analysis revealed the maximum velocity to be 6630 fps. The total engine burn time was 141.4 seconds, which compared favorably with the 141 seconds planned. However, the aircraft had achieved a velocity which was 130 fps faster than that of the simulator during this time.

During the deceleration the pilot was concentrating on performing stability and control maneuvers and as a result the profile was not exactly as planned. After shutdown the aircraft did not descend at the rate planned, resulting in a lower dynamic pressure between 5500 and 4000 fps. This anomaly, along with the higher maximum velocity, presented the pilot with the task of managing higher energy in approaching the high key position. The region of largest dispersion from the planned ranging occurred at the time when the dynamic pressure was lower than planned. To regain the desired high key energy conditions, the pilot delayed the retraction of the speed brakes and flew the remainder of the deceleration at a higher dynamic pressure (a maneuver commonly used on X-15 flights).

The ability of the ablative material to protect the aircraft structure from the high aerodynamic heating was considered good except in the area of the dummy ramjet where the heating rates were significantly higher than predicted. Considerable heat damage occurred on the dummy ramjet and the ramjet pylon. The ramjet instrumentation ceased approximately 25 seconds after engine shutdown indicating that a burn through of the ramjet/pylon structure had occurred. Shortly thereafter the heat propagated upward into the lower aft fuselage area causing the engine hydrogen peroxide hot light to illuminate in the cockpit. Ground control, assuming a genuine overheat condition, requested the pilot to jettison the remaining engine peroxide. The high heat in the aft fuselage area also caused a failure of a helium control gas line allowing not only the normal helium source gas to escape, but also the emergency jettison control gas supply as well (because of the failure of a check valve). Thus, the remaining residual propellants could not be jettisoned. The aircraft was an estimated 1500 pounds heavier than normal at landing, but the landing was accomplished without incident.

The pilot performed a rudder pulse with the yaw damper off 71 seconds after engine shutdown and noted that the sideslip indicator did not oscillate as expected. Post-flight analysis of the maneuver revealed that the aircraft did in fact experience a reasonable yaw rate and lateral acceleration. The maneuver was performed at approximately the time of maximum temperature for the unprotected Ball Nose. It was concluded that the sphere of the Ball Nose experienced binding, possibly due to differential expansion.

The heat in the ramjet pylon area became high enough to ignite 3 of the 4 explosive bolts retaining the ramjet to the pylon at some time during the flight. As the pilot was performing a turn to downwind in the landing pattern, the one remaining bolt failed structurally and the ramjet separated from the aircraft. The pilot did not feel the ramjet separate. Since the landing chase aircraft had not yet joined up, the pilot was not aware that the unit had separated.

The position of the aircraft at the time of separation was established by radar data and the most likely trajectory estimated. A ground search party

discovered the ramjet impact point on the Edwards AFB bombing range. Although it had been damaged by impact, it was returned for study of the heat damage that had occurred.

RAMJET SEPARATION CONDITIONS

FLIGHT NO. 2-53-97

Velocity	980 fps	Angle of attack	8°
Altitude	35,500 feet	Roll angle	57° left
Mach Number	.98	Normal accel.	1.6 g
Dynamic Pressure	340 psf		

The unprotected right-hand windshield was, as anticipated, partially covered with ablation products. With the pilot's visibility being restricted (the left window was still covered by the eyelid) his guidance to the high key position was based on radar vectors from ground control. The eyelid was opened at approximately 1.6 Mach number as the aircraft was over Rogers Lake and the visibility out this window was good.

Knight landed at Edwards, the plane resembling burnt firewood. It had been an eventful flight; now the engineers sat down and took a long look at what it all meant.

What it really meant was the end of the refurbishable spray-on ablator concept. It was the closest any X-15 came to structural failure induced by heating. The plane was charred on its leading edges and nose cap. The ablator had actually prevented cooling of some hot spots by keeping the heat away from the craft's metal heat-sink structure. On earlier flights without the ablator, some of those areas remained relatively cool because of heat transfer through the heavy Inconel structure. Some heating effects, such as at the tail and body juncture and where shockwaves intersected the

structure, had been the subject of theoretical studies, but had never before been seen on an actual aircraft in flight. To John Becker at Langley, the flight underscored "the need for maximum attention to aerothermodynamic detail in design and preflight testing."<sup>16</sup> To Jack Kolf, an X-15 project engineer at the FRC, the X-15A-2's condition "was a surprise to all of us. If there had been any question that the airplane was going to come back in that shape, we never would have flown it."<sup>17</sup> The ablator had done its job, but refurbishing for another flight near Mach 7 would have taken five weeks. Technicians would have had great difficulty in ensuring adequate depth of the ablator over the structure. Obviously, a much larger orbital vehicle would have had even greater problems. The sprayed-on refurbishable ablator concept thus died a natural death. The unexpected airflow problems with the ramjet ended any idea of using that configuration on the X-15, as did the ramjet's own shortcomings as a design (as is discussed subsequently). After the flight, NASA sent the X-15A-2 to its manufacturer for general maintenance and repair. Though the plane returned to Edwards in June 1968, it never flew again. It is now on exhibit--in natural black finish--at the Air Force Museum, Wright-Patterson AFB, Ohio. The third X-15 (serial 56-6672) featured specialized flight instrumentation and displays that rendered it particularly suitable for high-altitude flight research. A key element of its control system was a so-called "adaptive" flight control system developed by Honeywell; it automatically compensated for the airplane's behavior in various flight regimes, combining the aerodynamic control surfaces and the reaction controls into a single control "package." This offered much potential for future high-performance aircraft such as the anticipated Dyna-Soar and supersonic transports, should the latter be built.

By the end of 1963, this X-15 had flown above 50 miles, the altitude that the Air Force recognized as the minimum boundary of



spaceflight. FRC pilot Joe Walker set an X-15 record for winged spaceflight by reaching 354,200 feet, a record that stood until the orbital flight of Columbia nearly two decades later. These flights, and others later, acquired reentry data considered applicable to the design of future "lifting reentry" spacecraft. By mid-1967, the X-15-3 had completed sixty-four research flights, twenty-one at altitudes above 200,000 feet. It became the prime testbed for carrying experiments to high altitude, especially micrometeorite collection and solar-spectrum analysis experiments.

As had happened in some other research aircraft programs, a fatal accident signaled the end of the X-15 program. On November 15, 1967 at 10:30 a.m., the X-15-3 dropped away from its B-52 mothership at 45,000 feet near Delamar Dry Lake. At the controls was veteran Air Force test pilot, Maj. Michael J. Adams. Starting his climb under full power, he was soon passing through 85,000 feet. Then an electrical disturbance distracted him and slightly degraded the control of the aircraft. Having adequate backup controls, Adams continued on. At 10:33 he reached a peak altitude of 266,000 feet. In the FRC flight control room, fellow pilot and mission controller Pete Knight monitored the mission with a team of engineers. Something was amiss. As the X-15 climbed, Adams started a planned wing-rocking maneuver so an on-board camera could scan the horizon. The wing rocking quickly became excessive, by a factor of two or three. When he concluded the wing-rocking portion of the climb, the X-15 began a slow, gradual drift in heading; 40 seconds later, when the craft reached its maximum altitude, it was off heading by 15°. As the plane came over the top, the drift briefly halted, with the plane yawed 15° to the right. Then the drift began again; within 30 seconds, the plane was descending at right angles to the flight path. At 230,000 feet, encountering rapidly increasing dynamic pressures, the X-15 entered a Mach 5 spin.<sup>18</sup>

In the flight control room there was no way to monitor heading, so nobody suspected the true situation that Adams now faced. The controllers did not know that the plane was yawing, eventually turning completely around. In fact, control advised the pilot that he was "a little bit high," but in "real good shape." Just 15 seconds later, Adams radioed that the plane "seems squirrely." At 10:34 came a shattering call: "I'm in a spin, Pete." A mission monitor called out that Adams had, indeed, lost control of the plane. A NASA test pilot said quietly, "That boy's in trouble." Plagued by lack of heading information, the control room staff saw only large and very slow pitching and rolling motions. One reaction was "disbelief; the feeling that possibly he was overstating the case." But Adams again called out, "I'm in a spin." As best they could, the ground controllers sought to get the X-15 straightened out. They knew they had only seconds left. There was no recommended spin recovery technique for the plane, and engineers knew nothing about the X-15's supersonic spin tendencies. The chase pilots, realizing that the X-15 would never make Rogers Lake, went into afterburner and raced for the emergency lakes, for Ballarat, for Cuddeback. Adams held the X-15's controls against the spin, using both the aerodynamic control surfaces and the reaction controls. Through some combination of pilot technique and basic aerodynamic stability, the plane recovered from the spin at 118,000 feet and went into a Mach 4.7 dive, inverted, at a dive angle between 40 and 45°. <sup>19</sup>

Adams was in a relatively high altitude dive and had a good chance of rolling upright, pulling out, and setting up a landing. But now came a technical problem that spelled the end. The Honeywell adaptive flight control system began a limit-cycle oscillation just as the plane came out of the spin, preventing the system's gain changer from reducing pitch as dynamic pressure increased. The X-15 began a rapid pitching motion of increasing severity. All the while, the plane shot downward at 160,000 feet

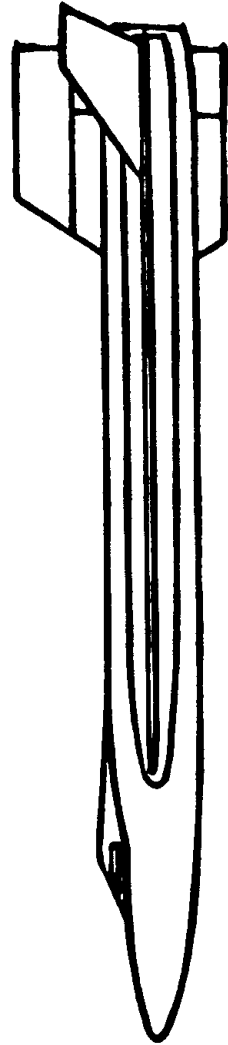
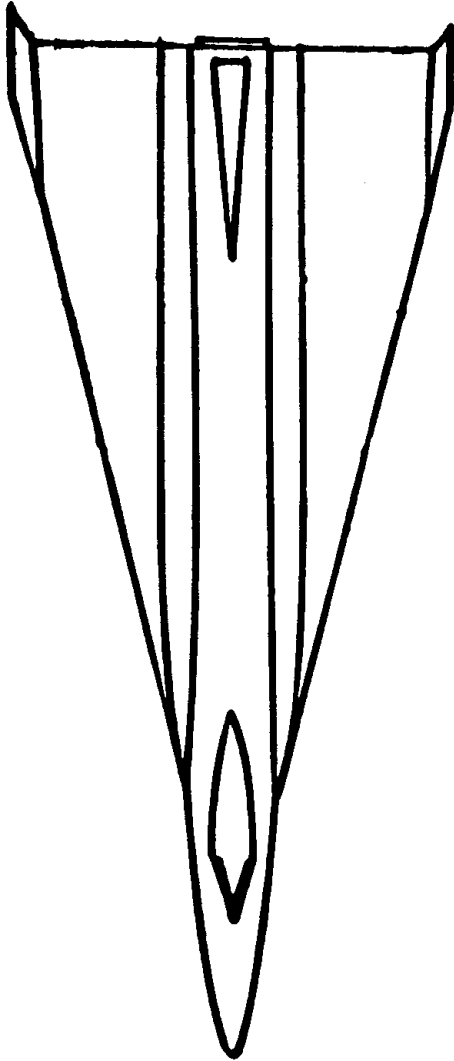
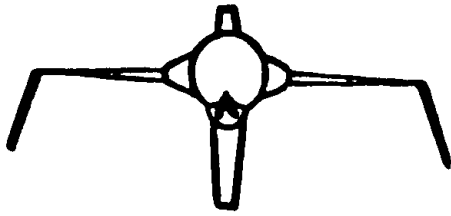
per minute, dynamic pressure increasing intolerably. High over the desert, it passed abeam of Cuddeback Lake, over the Searles Valley, over the Pinnacles, arrowing on toward Johannesburg. As the X-15 neared 65,000 feet, it was speeding downward at Mach 3.93 and experiencing over 15 g vertically, both positive and negative, and 8 g laterally. It broke up into many pieces amid loud sonic rumblings, striking northeast of Johannesburg. Two hunters heard the noise and saw the forward fuselage, the largest section, tumbling over a hill. On the ground, NASA control lost all telemetry at the moment of breakup, but still called to Adams. A chase pilot spotted dust on Cuddeback, but it was not the X-15. Then an Air Force pilot, who had been up on a delayed chase mission and had tagged along on the X-15 flight to see if he could fill in for an errant chase plane, spotted the main wreckage northwest of Cuddeback. Mike Adams was dead, the X-15 destroyed. NASA and the Air Force convened an accident board.<sup>20</sup>

Chaired by NASA's Donald R. Bellman, the board took two months to prepare and write its report. Ground parties scoured the countryside looking for wreckage, any bits that might furnish clues. Critical to the investigation was the cockpit camera and its film. The weekend after the accident, a voluntary and unofficial FRC search party found the camera; disappointingly, the film cartridge was nowhere in sight. Engineers theorized that the film cassette, being lighter than the camera, might be further away, to the north, blown there by winds at altitude. FRC engineer Victor Horton organized a search and on November 29, during the first pass over the area, W. E. Dives found the cassette, in good condition. Investigators meanwhile concentrated on analyzing all telemetered data, interviewing participants and witnesses, and studying the aircraft systems. Most puzzling was Adams' complete lack of awareness of major heading deviations in spite of accurately functioning cockpit instrumentation. The accident board concluded that he had allowed the aircraft to deviate as the result

of a combination of distraction, misinterpreting his instrumentation display--and possible vertigo. The electrical disturbance early in the flight degraded the overall effectiveness of the aircraft's control system and further added to pilot workload. The X-15's adaptive control system then broke up the airplane on reentry. The board made two major recommendations: install a telemetered heading indicator in the control room, visible to the flight controller, and medically screen X-15 pilot candidates for labyrinth (vertigo) sensitivity. As a result of the X-15's crash, FRC added a ground-based "8 ball" attitude indicator, displayed on a TV monitor in the control room, which furnished mission controllers with "real time" pitch, roll, heading, angle of attack, and sideslip information available to the pilot, using this for the remainder of the X-15 program.<sup>21</sup>

The X-15 program itself did not long survive the loss of the X-15 #3. The X-15A-2, grounded for repairs, soon remained grounded forever. The first X-15 continued flying, with sharp differences of opinion about whether the research results returned were worth the effort and expense. The ramjet program had offered hope to zealots that the program might continue, but the X-15A-2's experience really ended all that. A proposed delta wing X-15 modification had offered supporters the hope that the program might continue to 1972 or 1973, but the loss of the third X-15 ended this hope as well, inasmuch as it would have been the third aircraft that would have been modified as a delta hypersonic testbed. The proposed delta wing X-15 (Figure 5) had grown out of studies in the early 1960s on using the X-15 as a hypersonic cruise research vehicle. Essentially, the delta X-15 would have made use of the third airframe with the adaptive flight control system, but also incorporated the modifications made to the X-15A-2--lengthening the fuselage, revising the landing gear, adding external tankage, and provisions for a small-scale experimental ramjet. NASA proponents, particularly John Becker (chief of Langley's Aero-Physics Division)

Figure 5



found the idea very attractive since, as Becker wrote in one internal memo:<sup>22</sup>

The highly swept delta wing has emerged from studies of the past decade as the form most likely to be utilized on future hypersonic flight vehicles in which high lift/drag ratio is a prime requirement i.e., hypersonic transports and military hypersonic-cruise vehicles, and certain recoverable boost vehicles as well.

Despite such endorsement, support remained lukewarm at best both within NASA and the Air Force (indeed, only within the flight testing and hypersonic communities of both organizations was there ever much support for the X-15 program at all); the loss of Mike Adams and the third X-15 sealed the fate of the delta proposal, though the idea did influence in a roundabout way the subsequent attempts to build hypersonic sustained cruise technology demonstrators in the 1970s such as the National Hypersonic Flight Research Facility (NHFRF).

Perhaps because of the generalized feeling that the X-15 had long passed the point of productive and timely research--a feeling that program participants would have contested--support for the X-15 dropped dramatically after 1963. As early as March 1964, in consultation with NASA Headquarters, Brig. Gen. James T. Stewart, director of science and technology for the Air Force, had determined to end the program in December 1968.<sup>23</sup> The first X-15, the only one of the three still flying after the Knight and Adams' flights, had just about exhausted its research ability, and it cost roughly \$600,000 per flight. Other NASA programs could benefit from this funding, and thus NASA did not request a continuation of X-15 funding after December 1968.<sup>24</sup> During 1968 Bill Dana of NASA and Pete Knight of the AFFTC took turns flying the X-15, though a variety of weather, maintenance, and operational problems caused rescheduling and cancellation of a number of flights. On

October 24, 1968, Dana completed the first X-15's 81st flight, the 199th flight of the series. The plane attained Mach 5.38 at 255,000 feet, carrying a variety of follow-on experiments. Though researchers tried to get a 200th flight before the end of the year, weather, maintenance and operational problems dictated otherwise. The X-15 program, after nearly a decade of flight operations, came to an end.

## NOTES

1. Robert Mulac, X-15 flight chronology (NASA-Langley Research center, n.d.) Copy in the files of the NASA History Office, Washington, D.C. See also A. Scott Crossfield and Clay Blair, Always Another Dawn: The Story of a Rocket Test Pilot (Cleveland, OH: World Publishing Co., 1960), pp. 307-366.
2. Mulac, X-15 flight chronology: Crossfield and Blair, pp. 366-405; NASA, X-15 series flight log assembled by Betty J. Love, NASA DFRC.
3. Wendell Stillwell, X-15 Research Results (Wash., D.C.: NASA, 1965), p. 65. Stillwell's book is useful mostly for the information on the program prior to 1965. Interview with R. Dale Reed, 30 Nov. 1976.
4. Becker, "The X-15 Program in Retrospect." Raumfahrtforschung. See also Stillwell, p. 66; and James E. Love, "X-15: Past and Future," paper presented to the Fort Wayne Section, Society of Automotive Engineers, 9 Dec. 1964.
5. Stillwell, pp. 51-52, 75-78, for a general technical review of the X-15 effort, see Joseph Weil, NASA Technical Note D-1278, Review of the X-15 Program (Washington, D.C.: NASA, June 1962); Becker, "The X-15 Program in Retrospect."
6. Stillwell, p. iv; see also Walter C. Williams, "The Role of the Pilot in the Mercury and X-15 Flights." Proceedings of the Fourteenth AGARD General Assembly, 16-17 Sept. 1965, Portugal.
7. Weil, Review of the X-15 Program; James E. Love and W. R. Young, "Operational Experience from the X-15 Program," n.d., files of the DFRC Safety Office.
8. Betty Love, X-15 flight chronology, DFRC Pilots' Office files.
9. Love, "X-15: Past and Future," Becker, "The X-15 Program in Retrospect," memo on X-15 follow-on program by Homer Newell to Hugh Dryden, 18 Dec. 1961; undated memo, Bikle to Soulé (believed Nov. 1961); memo, Stack to Dryden, 3 Jan. 1962; ltr., Dryden to Maj. Gen. Marvin C. Demler, USAF, 12 Jul. 1962; NASA news release 61-261.
10. Air Force Systems Command, X-15 System Package Program, 6-37-48; Love, "X-15: Past and Future;" ltr., Dryden to Demler, 23 Mar. 1962; NASA news release 62-98; X-15 news release 62-91; ltr., Dryden to Lt. Gen. James Ferguson, 15 Jul. 1963; NASA news release 64-42; Carlton R. Gray, MIT/IL X-15 Horizon Definition Experimental Final Report (Cambridge, Mass.: MIT Instrumentation



Laboratory, Oct. 1969), passim.; NASA George C. Marshall Space Flight Center news release 68-69.

11. AFSC, X-15 System Package Program, 1-2; Robert A. Hoover and Robert A. Rushworth, "X-15A-2 Advanced Capability," paper presented at the annual symposium of The Society of Experimental Test Pilots, Beverly Hills, CA, 25-26 Sept. 1964.

12. Love, X-15 flight chronology; cockpit voice transcription for Rushworth flight, 14 Aug. 1964; X-15 Operations Flight Report, 19 Aug. 1964; Rushworth flight comments, n.d.

13. Hoover and Rushworth, "X-15A-2 Advanced Capability," NASA news release 66-11; C. M. Plattner, "Insulated X-15A-2 Ready for Speed Tests," Aviation Week & Space Technology (24 July 1967), pp. 75-81.

14. William J. Knight, "Increased Piloting Tasks and Performance of X-15A-2 in Hypersonic Flight," paper presented at the annual symposium of the SETP, Beverly Hills, CA, 28-30 Sept. 1967; Love, X-15 chronology.

15. Johnny G. Armstrong, Flight Planning and Conduct of the X-15A Envelope Expansion Program, AFFTC-TD-69-4; (Edwards AFB: AFFTC, 1969), pp. 52-56.

16. Becker, "The X-15 Program in Retrospect."

17. Interview with Jack Koll, 28 Feb. 1977.

18. Donald R. Bellman, et al., Investigation of the Crash of the X-15-3 Aircraft on November 15, 1967 (Edwards: NASA FRC, Jan. 1968), pp. 8-15.

19. Ibid.; passim; confidential interviews.

20. X-15 accident report, passim.

21. Ibid.; R. Dale Reed, "RPRV's: The First and Future Flights," Astronautics & Aeronautics (Apr. 1974), pp. 26-42.

22. For example, see the file "X-15: Mtg re research related to Hypersonic Cruise Vehicle," NASA History Office, Washington, D.C., particularly memo, John Becker to Floyd Thompson, 29 Oct 1964; ltr., Paul Bikle to C. W. Harper, 13 Nov. 1964; and Becker, et. al., "Proposed Aerodynamic and Heat Transfer Experiments," n.d. (transmitted by Floyd Thompson to A. J. Evans, 25 Jan 1965).

23. USAF Hq. Development Directive No. 32, 5 Mar. 1964, reprinted in X-15 System Package Program, 13-7.

24. James E. Love and William R. Young, NASA TN D-3732, "Survey of Operation and Cost Experience of the X-15 Airplane as a Reusable Space Vehicle" (Washington, D.C.: NASA, Nov. 1966), p. 7; Bikle interview; Finch interview.

## CHAPTER VII

### THE LEGACY OF THE X-15

The conclusion of the X-15's flight test program brought an era in flight testing history to a close. In 199 flights, the X-15 spent eighteen hours above Mach 1, twelve hours above Mach 2, nearly nine hours above Mach 3, nearly six hours above Mach 4, one hour above Mach 5, and scant minutes above Mach 6. It flew to Mach 6.72 (4,520 mph) and an altitude of 67 miles. Twelve pilots flew it, and one of them died. Beginning as a hypersonic aerodynamics research tool, the X-15 eventually became much more than that. What, then, did it accomplish?

In October 1968 John Becker enumerated 22 accomplishments from the research and development work that produced the X-15, 28 accomplishments from its actual flight research, and 16 from testbed investigations. As of May 1968, the X-15 had generated 766 technical reports on research stimulated by its development, flight testing, and test results, equivalent to the output of a typical 4000-man federal research center working for two years. As the X-15 had provided a focus and stimulus for supersonic research, the X-15 furnished a focus and stimulus for hypersonic studies. A sampling of its accomplishments indicates their scope:<sup>1</sup>

- Development of the first large restartable "man-rated" throttleable rocket engine, the XLR-99.
- First application of hypersonic theory and wind-tunnel work to an actual flight vehicle.
- Development of the wedge tail as a solution to hypersonic directional stability problems.
- First use of reaction controls for attitude control in space.

- First reusable superalloy structure capable of withstanding the temperatures and thermal gradients of hypersonic reentry.
- Development of new techniques for the machining, forming, welding, and heat-treating of Inconel X and titanium.
- Development of improved high-temperature seals and lubricants.
- Development of the NACA "Q" ball "hot nose" flow-direction sensor for operation over an extreme range of dynamic pressures and a stagnation air temperature of 1900°C.
- Development of the first practical full-pressure suit for pilot protection in space.
- Development of nitrogen cabin conditioning.
- Development of inertial flight data systems capable of functioning in a high-dynamic pressure and space environment.
- Discovery that hypersonic boundary layer flow is turbulent and not laminar.
- Discovery that turbulent heating rates are significantly lower than had been predicted by theory.
- First direct measurement of hypersonic skin friction, and discovery that skin friction is lower than had been predicted.
- Discovery of "hot spots" generated by surface irregularities.
- Discovery of methods to correlate base drag measurements with tunnel test results so as to correct wind tunnel data.
- Development of practical boost-guidance pilot displays.
- Demonstration of a pilot's ability to control a rocket-boosted aerospace vehicle through atmospheric exit.
- Development of large supersonic drop tanks.
- Successful transition from aerodynamic controls to reaction controls, and back again.

- Demonstration of a pilot's ability to function in a weightless environment.
- First demonstration of piloted, lifting atmospheric reentry.
- First application of energy-management techniques.
- Studies of hypersonic acoustic measurements used to define insulation and structural design requirements for the Mercury spacecraft.
- Use of the three X-15 aircraft as testbeds carrying a wide variety of experimental packages.

The X-15 also made its mark in many other ways. When NACA began its development, the science of hypersonic aerodynamics was in its infancy; the few existing hypersonic tunnels were used largely for studies in fluid mechanics. Aerodynamicists feared that there might be a hypersonic "facility barrier," much like the earlier transonic tunnel trouble that led to the Bell X-1 and Douglas D-558, so that hypersonic tunnel tests might prove of little value in predicting actual flight conditions. The X-15 disproved this; predicted wind tunnel data and data flight testing of the airplane generally showed remarkable agreement. Proving that hypersonic laminar flow conditions did not develop led to the disappearance of this "technical superstition," and recognition that the small surface irregularities that prevent laminar flow at low speed also prevent its formation at hypersonic speeds. Like the earlier X-1, the X-15 encouraged a great deal of ground research and simulation techniques. So successful were these methods and so great was the engineers' confidence in these methods and the X-15's flight results that the X-15 wound up actually decreasing the likelihood of NASA's developing any future hypersonic research aircraft with the prime justification being the generation of unique and otherwise unobtainable data. Any future research aircraft would be built more for "proof of concept" purposes than for acquiring information unobtainable by other means. At the conclusion of the X-15 program, the German Society

of Aeronautics and Astronautics presented the NASA X-15 team with the Eugen Sänger Medal--a fitting and appropriate honor. In his acceptance address on behalf of the team, John Becker stated that "no new exploratory research airplane can ever again be successfully promoted primarily on the grounds that it will produce unique flight data without which a successful technology cannot be achieved."<sup>2</sup>

Nearly ten years after Becker's assessment, Capt. Ronald G. Boston of the U.S. Air Force Academy's history department reviewed the X-15 program for "lessons learned" that might be applied or benefit the development of the National Hypersonic Flight Research Facility Program, an effort that itself died shortly thereafter. Boston's study, presented in clipped outline style, offers an interesting perspective on the X-15 both from the vantage point of history, as well as giving an inkling of the state of the art in hypersonic studies in the mid-1970s on the eve of the Shuttle in light of the X-15's experience. Reprinted here in full, it provides an interesting complementary viewpoint to that of X-15's originator John Becker:<sup>3</sup>

#### THE X-15's ROLE IN AEROSPACE PROGRESS

This outline presents a synopsis of X-15's contributions to aerospace technology and is intended as a preliminary report on the X-15 historical study conducted as part of the National Hypersonic Flight Research Facility (NHFRF) feasibility study. Specifically, this study looks to see of what value the developments and lessons of the X-15 program have been. It is a case study of the X-15 program intended to show the value of research aircraft.

Covered in this study are two general types of contributions made by the X-15: revolutionary and evolutionary. Revolutionary

contributions are those technological breakthroughs that open new fields, that are dependent upon the advanced capabilities of the research aircraft, and that are sometimes totally unexpected. Evolutionary contributions include those for which the research vehicle represents the latest and most advanced stage in the developmental process. While the latter may not be dependent upon the particular aircraft's capabilities, the demands of the research program nonetheless drive the technology toward a greater degree of perfection. The two types are often confused; yet, only the former provides legitimate justification for undertaking a research program. But in an evaluation in retrospect, both forms of contribution make up the ultimate worth of a program.

The study begins with the X-15 program's goals and examines the degree of success achieved. It covers the lessons learned, both intentional and unintentional in origin. It then looks to the present time to see what, if any, uses have been made of the knowledge gained. Lastly, this study poses the questions raised but left unanswered in the conduct of this program.

#### 1. Program Overview:

a. Goals and Design Philosophy. Using near-state-of-the-art (1954) technology to propel a conservative Mach 2 design out to Mach 6 and 250,000 feet to explore the hypersonic and near-space environments:

- (1) To verify existing theory and wind-tunnel techniques.
- (2) To study aircraft structures under high (1200F) heating.
- (3) To investigate stability and control problems associated with high-altitude boost and re-entry.
- (4) To investigate the biomedical effects of both weightless and high-g flight.

b. Achievements and Ultimate Utilization. All design goals were met; most were surpassed: Mach 6.7, 354,200 feet, 1300 degrees F, and 2,000 pounds per square foot (psf). In addition, once the original research goals were accomplished, the X-15 became a handy high-altitude, hypersonic testbed for which 46 follow-on experiments were designed--majority flown before the program was abruptly terminated in 1968. Many proposals for modifying or optimizing the basic airframe surfaced during the course of the program, and the X-15 was envisioned as a hypersonic facility for the 1970s. Due to the absence of a subsequent hypersonic mission, aircraft applications of X-15 technology have been few. In space, however, the X-15 paved the way for manned, orbital and lunar flight.

## 2. Hypersonic Aerodynamics:

a. Hypersonic Flow. The X-15 program remains the most thoroughly tested aircraft program to date and offered an excellent opportunity to compare actual flight data with theory and wind-tunnel predictions. The X-15 verified existing wind-tunnel techniques for approximating interference effects for high-Mach, high-angle-of-attack hypersonic flight, thus giving increased confidence in small scale techniques for hypersonic design studies. Wind-tunnel drag measurements were also validated, except for the 15 percent discrepancy found in base drag--masked by the "sting" support used in the tunnel. The laminar boundary layer theory for hypersonic flight was disproven, the flow actually being almost entirely turbulent. X-15 flight-test data indicated that hypersonic flow phenomena are linear above Mach 5, allowing us to design with confidence craft like the Mach 25-30 Shuttle Orbiter that must fly as expected without the cautious "buildup" program of the X-15.

b. Stability and Control. X-15's experience disproved the existence of "barriers" to hypersonic flight as were suspected



after the X-1 and X-2 aircraft encountered extreme, high-supersonic instability.

(1) "Wedge Tail." A redesigned vertical stabilizer reduced the instability that plagued the X-1 series and X-2 aircraft.

(2) "Rolling Tail." Differentially deflected horizontal stabilizers gave precise roll control and allowed for elimination of ailerons out on a hot wing section. This design concept was later incorporated into the "swing wing" of the B-1 bomber to simplify wing construction.

(3) "Tunnel Parameter Verification." X-15 data verified wind-tunnel parameters used for aerodynamic stability prediction above Mach 2. Flight test results also pointed out the need for an "error band" or degree of uncertainty to be put on such predictions. AFFTC and NASA Dryden Flight Research Center have both made inputs to the Shuttle program in this regard based on past flight test experience, the X-15 providing the only parameter's experience above Mach 2.

(4) "Side-Stick Controller." The first modern application of the side-stick concept for more precise, "wrist-action" control--as now comes standard in the F-16.

(5) "Augmentation." Some phases of flight, such as reentry, were marginally stable, and pilots required artificial augmentation (damping) to achieve satisfactory stability. The X-15 necessitated the development of one of the earliest stability augmentation systems (SAS). Originally equipped with a simple fail-safe, fixed-gain system, one of the three ships was later equipped with a triply redundant adaptive flight control system (AFCS). Here the pilot flew via inputs to the electrical augmentation system. Though a point of continuing debate, the X-15 did not incorporate "fly-by-wire" if meant to denote a non-mechanically linked control system. A purely electric side stick had been developed under contract for the X-15 and test flown in a F-101B. Thus the X-15 did advance "fly-by-wire" technology.

c. Simulation Techniques. The art of simulation grew with the X-15 program, not only for pilot training and mission rehearsal, but for research into controllability problems. Subject to continuous updating based on flight-test results, the simulator was programmed to "fly" like the aircraft. Thus the simulator could be used to explore those areas of the flight envelope too risky for actual flight. The demands of the X-15's wide velocity and altitude envelope necessitated development of the first full six-degree-of-freedom flight simulator. The X-15 program showed the value of good wind-tunnel testing and simulation in maximizing the knowledge gained from each of the 199 short, expensive test flights.

d. Aerodynamic Heating Effects. In a major discovery, the existing Sommer-Short and Eckert T-prime heating prediction theories (laminar flow) were found to be 30 to 40 percent in excess of flight-test results. (Hence the X-15's structure was overdesigned for heating effects.) This discovery led to renewed wind-tunnel testing leading to NASA-Langley's choice of the empirical Spaulding-Chi model for hypersonic heating. Lighter, more optimum vehicles are now possible, the Apollo command and service modules being a case in point. Based on their X-15 experience, Rockwell International devised a computerized mathematical model for aerodynamic heating called HASTE--Hypersonic and Supersonic Thermal Evaluation--which gives a workable "first cut" approximation for design studies. HASTE was, for example, used directly in the initial Apollo design study.

### 3. Structures:

a. Development. X-15 was designed as a "heat sink" structure to absorb heat pulses, not to withstand hypersonic cruise heating. Development showed the validity of ground "partial simulation" testing of primary members stressed under high temperature. A

facility was since built at DFRC for heat-stress testing of the entire structure. X-15's development pioneered the use of corrugations and beading to relieve thermal expansion stresses (as now used on YF-12/SR-71, though Lockheed disclaims any X-15 inputs). Metals with dissimilar expansion coefficients were also used to alleviate stresses. The leading edges were segmented, much like a concrete sidewalk, to allow for expansion. The X-15 required the perfection of fabrication (milling and welding) techniques for high temperature alloys: Inconel X (skin) and titanium (structural members) had heretofore not been extensively used to such fine specifications. Such is now routine in aircraft and spacecraft construction.

b. Flight Stresses. Though the primary structure proved sound, several surface design problems were uncovered during early flight tests.

(1) Local Hot Spots. A surprise lesson came with the discovery of heretofore unconsidered local heating phenomena. Tiny slots in the leading edge material, the abrupt contour change along the canopy, and the wing root caused flow disruptions that produced excessive heating and adjacent material failure. The X-15, tested in "typical" panels or sections, demonstrated the problems encountered when those sections are joined and thus precipitated an analytical program designed to predict such local heating stresses. Today, from this experience, Rockwell engineers are closely scrutinizing the segmented, carbon-carbon composite leading edge of the Shuttle Orbiter's wing. The bi-metallic "floating retainer" concept designed to dissipate stresses across the X-15's windshield carried over to Rockwell's Apollo and Shuttle windshield designs as well.

(2) Hot Air Leaks. Hot boundary-layer air on several occasions seeped into the nose-gear compartment, damaging gear and compartment and causing high-speed extension of the gear. The need

for very careful examination of all seals thus became apparent, and closer scrutiny of surface irregularities, small cracks, and areas of flow interaction became routine. Consequently, Rockwell engineers are now examining the seal around the Orbiter's thermal surface tiles.

(3) Panel Flutter. Incidences of X-15's panel flutter led to an industry-wide re-evaluation of panel flutter design criteria in 1961-1962. Stiffeners and reduced panel sizes alleviated the problems on the X-15's upper vertical stabilizer and side fairings. Similar techniques later found general application in the high-speed aircraft of the 1960s.

(4) Boundary Layer Noise. The X-15 provided the first opportunity to study the effects of acoustical fatigue over a wide range of Mach and dynamic pressures. In these first inflight measurements, "noise" related stresses were found to be a function of g-force, not Mach number. Such fatigue was determined to be no great problem for a structure stressed to normal inflight loading. This knowledge has allowed for more optimum structural design of missiles and space capsules that experience high velocities.

c. Fabrication Techniques. Working with the hard nickel alloy Inconel X required new fabrication techniques. New welding, drilling, forming, and milling methods were perfected and are commonplace with the tough aerospace alloys now in use. The "Chem-Mill," or chemical milling, was a North American Aviation development that got its first test in reducing the center portions of skin panels to reduce weight. North American also pioneered a new spar construction to combat thermal expansion: the X-15's "hat" - spar construction, which gave compressive strength while reducing secondary stresses, has evolved into the "sine wave" spar used on the B-1 and other supersonic aircraft. To remedy the thermal buckling along the side fairings, North American also pioneered the use of expansion joints that nonetheless retained fuselage structural integrity. Indeed, the fuselage itself was

used as the fuel tanks, advancing the concept of integral tankage to reduce weight.

#### 4. Manned Flight:

a. Bioastronautics. Coming at a time when serious doubts were being raised concerning man's ability to handle complex tasks in the high-speed, weightless environment of space, the X-15 program became the first program for repetitive, dynamic monitoring of pilot heart rate, respirations, and EKG under extreme stress over a wide range of speeds and forces. When pre-existing, theoretical limits for heart rate were exceeded, all estimates of man's ability to endure stress had to be revised upward. Accelerated heart rates therefore caused no undue alarm or mission aborts for the subsequent manned space program. In fact, X-15's success gave the confidence to go ahead with early manned Mercury flights--the down-range ballistic shots being similar to the X-15's mission profile--at a time of great political concern over the success of America's first space program. Biomedical monitoring as begun with the X-15 has continued at DFRC. Pilot functions are being studied with an eye to devising the means to monitor pilot response and alertness from the ground as a function of vital measurements.

(1) Instrumentation. The bioinstrumentation developed for the X-15 program has allowed similar monitoring of all subsequent flight test programs. Incorporated in the pressure suit, pickups are unencumbering and compatible with aircraft electronics. The flexible, spray-on wire leads have since found use in monitoring cardiac patients in ambulances.

(2) Pressure Suit Development. The A/P-22S-2, the first single-piece, full pressure suit, was developed for the X-15 program. Later it was refined as the A/P-22S-6 suit, which remains the standard USAF operational suit for high-altitude flight.

b. Manned Flight Operations. America's space and advanced manned vehicle programs are all indebted to the X-15 for some aspect of their training, command and control, or recovery procedures. The X-15 not only demonstrated the value of man at the controls, but provided the accepted methodology for experimental manned programs.

(1) Pilot-in-the-Loop. The X-15 provided for no ground-based control input or override; the pilot remained constantly "in the loop," controlling and correcting aircraft attitude. He provided a highly sophisticated onboard "computer" and also served as the primary backup system for redundancy. Statistics show that without a pilot in control, the 3 aircraft would have sustained 15 losses on the first 47 flights alone. Overall mission success rate stood at 96 percent, versus 80 percent for component reliability. The pilots were able to recognize and override malfunctions to complete the primary or alternate missions to greatly enhance the worth of the program.

(2) Crew Training. The opportunity to observe the pilot's performance under high-stress and high g-forces also dictated that an extensive ground training program be instituted to prepare pilots to handle the complex tasks and mission profiles. The result was a simulation program that became the foundation for crew training for all manned space work. The program depended on four types of training simulation.

(a) Six Degree-of-Freedom Fixed-Base. A static cockpit mockup provided the means for extensive mission rehearsal--averaging 20 hours per 10 minute flight. Such preparation was directly responsible for the high degree of mission success achieved as pilots rehearsed their primary, alternate, and emergency diversion mission profiles.

(b) Dynamic Simulation. Prior to the first X-15 mission, the ability of the pilot to function under the high g-forces expected on boost and re-entry was tested in a

closed-loop, six degree-of-freedom simulation using the centrifuge at the Naval Air Development Center, Pa. This simulation "first" had the pilot controlling the g-forces and demonstrated pilot ability to function under 12 to 15 g's--more than ever experienced on actual flights. This project became the prototype for programs set up at the Ames Research Center and the Manned Spacecraft Center at Houston.

(c) Variable Stability Aircraft. X-15 pilots maintained proficiency and adaptability by practicing on T-33 and F-100 aircraft whose handling characteristics could be varied in flight, simulating the varied response of the X-15 traversing a wide range of velocities and atmospheric densities.

(d) Approach and Landing. Pilots practiced the exacting, low L/D landing maneuver in F-104 aircraft. With gear and speed brakes extended, the F-104's power-off glide ratio approximated that of the unpowered X-15. Shuttle Orbiter crews continue this same practice.

(3) Command and Control. The "NASA 1" control room located atop DFRC was the model for establishing the Mission Control Center (MCC) at Houston. Back up systems monitors and flight trackers were duplicated. Astronaut Capsule Communicators, "Cap-Comms," were a direct outgrowth of the X-15's practice of using an X-15 pilot as the ground communicator for all X-15 missions. Of course, all subsequent work at Edwards relied on X-15's spawned methodology. The X-15 program required an elaborate tracking network known as "High Range." Operational techniques were established for real-time monitoring and trajectory correction. These were carried over to the space program--the very same NASA personnel went on to set up the world-wide MCC tracking system.

(4) Re-entry and Landing. By demonstrating the operational feasibility of high angle-of-attack, "lifting" re-entries to unpowered, low L/D recoveries and landings, the X-15 paved the way for the lifting-body programs and the current Shuttle

Orbiter concept. Accordingly, landing-assist rockets intended to ease the touchdown of the Shuttle Orbiter were ultimately eliminated from the Orbiter design. X-15 pilots routinely landed within 1,000 feet of target with 70 percent reliability. The techniques for ground-monitored energy management to arrive overhead the landing spot at a "high key" originated with the X-15 program. Here the extreme altitudes and distances from touchdown exceeded the pilot's ability to make a visual, "deadstick" recovery as in preceding rocket aircraft programs. The terminal approach for the Shuttle Orbiter is a variation of the 360-degree, overhead pattern flown by the X-15: the Orbiter will enter figure-eight "energy-dissipation circles" overhead the approach end of the field until energy is reduced to within landing limits. Thus X-15 operations experience, more than any other source, provides the basic framework for the research programs of the 1970s and 80s. In fact, in 1958 North American Aviation proposed launching an X-15 into orbit for subsequent recovery.

5. Component Systems: The extreme speed and altitude demands of the X-15 program forced development of a number of advanced sub-systems that continue to yield dividends long after the program's termination.

a. Flight Data Systems. The X-15 required a choice be made between four possible approaches to flight data: 1) pressure instruments; 2) ground-based radar monitoring; 3) simple gyroscopic instruments; or 4) true inertial systems. The inertial approach, then very primitive, augmented with pressure instruments and radar, was selected.

(1) Air-Data Sensors. For subsonic flight the X-15 relied on simple pilot-static pressure instruments. (Later in the program, an extendable pitot tube was added when the velocity envelope was expanded beyond M6.) Mach, dynamic pressure, static



pressure, and altitude for hypersonic flight were telemetered from the ground where "High Range" computers evaluated radar inputs and ambient atmospheric conditions gathered by sounding rockets. Angle of attack and yaw were derived from a null-seeking "ball nose" which measured the pressure differentials felt across ports in the ball. The ball nose was later modified to measure static pressure to monitor dynamic pressure [ $q = f(P_t)$ ] which gave the pilot the ability to limit or hold a constant dynamic pressure. Thus far the ball nose has not found subsequent application. The Shuttle Orbiter will rely on redundant, onboard inertial systems backed up by ground radar.

(2) Inertial Flight Data Systems (IFDS). Onboard measurement of velocity was handled by inertial systems. All three aircraft were initially equipped with analog-type systems which proved to be highly unreliable. Later, two aircraft, including the one aircraft with the adaptive control system, were modified with digital systems. In the subsequent parallel evaluation of analog versus digital IFDS, the latter was found to be superior. It was far more flexible and could make direct inputs to the adaptive flight control system; it was also subject to less error. This type is now the accepted approach, as will be used on the Shuttle Orbiter.

b. Landing Gear. The main landing gear represented a marked departure from the standard pneumatic tire and retractable strut--as were retained in the nose-gear assembly. To reduce storage and heating problems, Inconel X skids were spring-loaded along the aft underside of the fuselage. This highly successful arrangement was programed for the X-20 Dyna-Soar and will be seen on the Rockwell HiMAT (High Maneuvering Aircraft Technology) RPV. One surprise lesson on the slap-down loading problems that low L/D aircraft with extremely aft-mounted main gear can experience was learned: the nearly immediate loss of lift as the nose lowered on touchdown caused unexpectedly high gear loads which resulted in gear failure and a major accident in 1962.

c. Aerospace Hardware. The combination of high aerodynamic heating and cryogenic liquids posed severe problems for the X-15's designers. From their efforts have come thermal insulators for hydraulic lines and actuators which are used today in the Shuttle Orbiter, high-temperature hydraulic fluids, cryogenic tubing as used directly in Apollo components, and experience with Inconel and titanium pressure vessels to withstand extreme temperature and pressure gradients. By way of costly aborts, engineers learned almost embarrassing lessons such as the need to pressurize the gear boxes of auxiliary power units taken to the low ambient pressure of space--where foaming of the lubricant caused material failures.

d. Cabin Environmental Systems. The X-15 presented the first requirement for full space-environment human engineering. While life support was provided by the full pressure suit, cockpit and electronics bay air-conditioning used the first cryogenic (liquid nitrogen) cooling system--designed by Garrett-Air Research, who went on to do the environmental controls for the Mercury capsules.

e. Reaction Controls. The X-15 provided the first operational test of hydrogen-peroxide reaction controls outside the earth's atmosphere. Designed by Bell Aerospace and flown on their X-1B to 75,000 feet in 1958 (not outside aerodynamic control effects), this system represented a true technological leap when included in the X-15 design in 1956. It later went into the Mercury spacecraft as the primary control system.

f. Propulsion. The X-15 was powered by the XLR-99 liquid-fueled rocket motor. Produced specifically for the X-15 mission, this complicated motor pioneered the concept of a throttleable, restartable motor with an idle-power feature. At idle, the XLR-99 could complete 55 percent of its start and light-off sequence before drop. This complexity also resulted in many aborted missions (approximately one-tenth of all mission aborts). The

requirement for a "man-rated" fail-safe system further compromised reliability. Through hindsight a number of X-15 engineers now feel the throttleable future to have been a needless luxury that complicated and delayed the development of the XLR-99--this feature has not been used on subsequent motors. However, the production effort did give confidence in the concept, and six XLR-99 throttleable motors yet remain in storage for some future reuse.

The full value of X-15's experience to the designing of sub-systems for advanced aircraft and especially spacecraft can only be guessed at. At Rockwell International Corporation (Los Angeles Aircraft Division) many of the same people from the X-15 project worked on the Shuttle Orbiter. Yet X-15's experience is overshadowed by more recent projects and becomes exceedingly difficult to trace as systems evolve through successive programs. Nonetheless, those engineers are confident that they owe much to the X-15, even though many are at a loss to give any concrete examples.

6. Follow-on Experiments: By roughly 1963 the X-15 had completed its original research objectives. There was talk of terminating the program entirely; there was even talk of closing DFRC for want of further flight research programs. New life was given to both as proposals for research needing either the speed or altitude of the X-15 surfaced. In the early 1960s the X-15 alone had the capability to carry a payload of much weight (or size) above the atmosphere. And unlike in missile research, the X-15 returned equipment and results for re-evaluation, recalibration, and reuse. Perhaps the earliest true "follow-on" experiment came in 1961: a coating material designed to reduce the infrared emissions of the B-70 was tested to Mach 4.43 (525F) on the exterior surface of an X-15 stabilizer panel. Thus began a series of 46 additional experiments concerning the physical sciences, space navigation aids, reconnaissance studies, and advanced aerodynamics--many of the 46 were left unfinished when the X-15 program ended in 1968.

a. Physical Sciences. Of special concern to scientists was the X-15's ability to carry experiments above the attenuating effects of the earth's atmosphere.

(1) Ultraviolet Stellar Photography. This astronomical study required photometering of the ultraviolet brightness of several of the brighter stars to study the material make-up of stars. The X-15 carried four cameras (on a gimbaled platform in the instrument bay behind the pilot) above the filtering effects of the ozone layer--approximately 40 miles up. Conducted in 1963 and again in 1966, this work was subsequently continued on improved sounding rockets.

(2) Atmospheric Density Measurement. The X-15 was ideally suited to measure densities of the 30 to 74 kilometer altitudes, crosschecking measurements on ascent with those on descent. Using the ball nose to take measurements, flow-angularity errors were eliminated. The X-15 provided atmospheric density profiles of seasonal variation.

(3) Micrometeorite Collection. Designed to collect samples at various altitudes, this experiment was part of a larger NASA study to build a particle-impact data base for spacecraft design criteria. Only on the last of six flights did this experiment "catch" any particles, those being so contaminated by reaction control jet particles that the project was cancelled.

(4) Rarefied Gas Flow. This experiment failed to provide any useful information despite repeated attempts.

(5) Solar Spectrum Measurements. The X-15 provided the first direct measurement from above the atmosphere of the sun's irradiance. A scientific revelation, this data allowed refinement of the Solar Constant of Radiation which was revalued 2.5 percent lower than existing ground-based determinations. This vital constant provides a measure of thermal energy incident on the earth and upon which all photochemical processes depend. It is also useful for the design of thermal protection for spacecraft.

b. Space Navigation:

(1) Horizon Definition. The X-15 supported two--MIT and NASA-Langley--projects to determine the earth's infrared horizon-radiance profile. This information has been used in attitude referencing systems for orbiting spacecraft. The MIT work was part of an Apollo support program seeking alternative means for earth's-orbit reinsertion guidance in case of radar or communications failure. The space sextant designed for this task was checked enroute on Apollo missions 8, 10, and 11 with relatively good accuracy when compared to radar position.

(2) High-Altitude Daytime Sky Brightness. This successful program to collect data on radiation characteristics of the daytime sky background was part of an effort to develop a "star tracking" navigational system. Such an automatic electro-optical tracking system is now used on SAC reconnaissance planes and has applications in satellite positioning and space travel.

c. Reconnaissance Systems. The X-15's speed and altitude combined to make it an ideal testbed for high-speed aircraft and satellite systems development.

(1) Ultraviolet Studies. Ultraviolet (UV) sensors were studied as ICBM early warning detectors. This three-part project yielded promising results, but to date UV systems remain overshadowed by the more advanced infrared systems.

(a) UV Earth's Background. Good data was obtained on the UV background against which the UV signature of an ICBM's exhaust could be detected.

(b) Exhaust Plume Characteristics. To determine the signature of a typical rocket exhaust above the ozone layer, the exhaust plume of the X-15 itself was scanned.

(c) Pacific Missile Range Monitor. To test the feasibility of detecting a missile launch by its UV signature, an

actual launch from Vandenberg AFB was to be monitored. However, due to equipment malfunctions, scheduling problems, and ultimately a snow storm which prevented the last scheduled X-15 flight, this test was never possible.

(2) Infrared Studies. Infrared (IR) work was devoted to two separate projects:

(a) Space Detection Systems. The current satellite detection systems began as X-15 IR experiments. Early (1963) experiments studied the IR exhaust plume characteristics of the X-15. The follow-up project to measure the earth's IR background using an IR scanner never flew before the X-15 program ended. Nonetheless, the equipment developed therein contributed directly to successful tests later carried by U-2 aircraft and thus to the eventual satellite program.

(b) IR Scanner. This experiment produced the first IR picture taken through a "hot" window. Though only a crude, two-dimensional image was obtained, the notion that hypersonic IR reconnaissance was impossible was disproven. This work also advanced the development of operational line scanners for mapping carried on RF-4, EF-111, and Navy aircraft. The Earth's Resources Development Agency (ERDA) even uses this technology to monitor pollution levels.

(3) Optical Background. This effort to determine daytime background interference effects to laser optics produced good data showing the feasibility of high-altitude laser surveillance. No actual pictures or images resulted, and this work has moved on to satellite testbeds.

(4) Aerial Photography. Optical degradation experiments determined that the shock wave, boundary-layer flow, and temperature gradients across windows caused negligible degradation to visual, near-IR, and radar aerial photography to Mach 5.5 and 125,000 feet. However, improved photographic equipment and much faster-speed films may very well invalidate these findings, hence the need for renewed flight testing. Toward the end of this

experiment several tests of near-IR color photography produced the first successful inflight use of color films. Such were later used in reconnaissance work over Southeast Asia where colored emissions could denote enemy activity under dense foliage. ERDA now uses this technique via satellites to study the earth's resources.

d. Advanced Aerodynamic Research. The X-15 served to carry aloft aerodynamic projects that were impractical for wind-tunnel study.

(1) Several tests of flow distortion over surface irregularities were run to verify wind-tunnel studies; little disparity between the two was noted.

(2) Attempts to measure cold-wall effects on coefficients of heating produced only marginal results, and this effort is still underway using the YF-12/SR-71 at DFRC.\*

(3) The feasibility of using fluidic (cavity) temperature probes to measure total temperature at high Mach, where standard probes burn away, was demonstrated.

(4) A complete re-entry guidance system for onboard, computerized energy management incorporating digital inputs to the adaptive flight control system was under study until the one aircraft so equipped was destroyed in 1967.

e. X-15A-2 Modification Program. The 1962 crash of aircraft number two opened the door for extensive modification since considerable rebuilding was required. The resultant modification, as the X-15A-2, was primarily aimed at providing a testbed for development of a Mach 8 hypersonic, airbreathing engine--the Hypersonic Ramjet Engine (HRE). Then, as now, no tunnel facility existed wherein such an engine could be realistically tested, and rocket boosters could not give steady-state tests or return the equipment.

\*Ed. note: The NASA YF-12 program concluded in 1979.

(1) HRE Program. The actual prototype engine was to be carried attached to the lower ventral of the X-15. Twenty-nine inches were added to the fuselage between the existing tanks for the liquid hydrogen to power the HRE. This compartment could also be used to carry other experiments and included a three-panel, high-heat resistant window in the belly. Two external fuel tanks were added alongside the fuselage and tucked under the wings to increase rocket-boost time to attain Mach 8. These tanks were jettisoned at about Mach 2. To withstand the added heating due to increased velocity, the entire aircraft surface was coated with an ablative-type insulator.

(a) Flight Program. Garrett-Air Research contracted to provide six prototype engines by mid-1969. In the meantime flight-test evaluations were made of the modified aircraft itself and of a dummy or mock-up HRE attached to the X-15A-2. On the first and only maximum-speed test of the X-15A-2 in 1967, shock impingement off the dummy HRE caused severe heating damage to the lower empennage, and very nearly resulted in loss of the aircraft. Though quickly repaired, the X-15A-2 never flew again as the X-15A-2's already cautious supporters abandoned the project. Hindsight would place the blame for this design oversight on haste and insufficient flow interaction studies. A key lesson learned from this episode was not to hang external stores or pylons on hypersonic aircraft, at least not without far more extensive study of underside flow patterns. The HRE was eventually tunnel tested in 1969, and the primary objective of achieving supersonic combustion was met, though the thrust produced was less than the drag created. HRE engineers nonetheless claim a success in that the objective was supersonic combustion, not a workable engine. The X-15 program can claim credit for spawning the HRE project, which has been continued on to the present at NASA-Langley. Though no realistic testbed yet exists, futuristic designs for a hypersonic research aircraft now envision internally mounted engine test facilities.



(b) Ablator Tests. Since Mach 8 exceeded the heating limits of the Inconel X, a spray-on ablator of silicone-based elastomeric material was chosen to protect the aircraft. The ablator was to limit skin temperatures to 500F in the 1900F environment of Mach 7.4 in this first-ever test of such insulation for an aircraft. Except where HRE pylon shock impingement caused a ten-fold rise in temperature, the ablator worked successfully to Mach 6.7. However, this approach was found to be operationally infeasible. Extensive man hours (approximately 20 days) were required to refurbish the charred ablator surface, and then the integrity of the ablator-to-skin bonding was of concern for subsequent flights. Other operational problems argued against spray-on ablatives: the crew could not walk on the vehicle; access panels were hard to remove and recover without leaving surface cracks; liquid oxygen if spilled on the ablator damaged the surface, requiring a coat of white paint to seal the ablative material's surface.

(c) Replaceable Wingtip. Though not a part of the HRE project, the right wing tip, damaged in 1962, was rebuilt to allow interchangeable wing-tip shapes. This facility portended valuable studies in the future, but was never utilized.

Though never labeled as such, the X-15 began to function as a hypersonic, high-altitude "facility" after the original research work was completed. A high percentage (perhaps half) of the follow-on experiments were failures. Critics have contended that in the rush to extend the life of the X-15 program, and DFRC, experiments of questionable value and hasty preparation were flown on the X-15. As early as 1964, NASA officials did begin questioning the cost effectiveness of the follow-on program. Yet the X-15 was the only facility available at the time, and some of the work produced results that contributed to vital programs of today, such as ballistic early warning. Unfortunately, the X-15 was not designed as a hypersonic facility, and thus was limited in its capability to do experimental work.

## 7. Conclusions:

a. Comment On Contributions. The X-15 was certainly successful in fulfilling its original research goals. Upon X-15's experience rests all subsequent hypersonic study, and the manned space program owes much of its hardware and operations techniques to the X-15. Yet any evaluation of X-15's contributions to technology is tenuous at best. Most systems, knowledge, and especially experience derived from the program have evolved through successive programs over the past decade, and contribution by the X-15 is often obscured. In other cases, the old "X-15 hands" can simply no longer recall what became of the work started on the X-15; this is especially true with the follow-on experiments. Nor is it possible to determine any time factor for the delay between X-15's research and the appearance of useful technology or applications. The nature of the X-15's work was too varied; then too, there has been no subsequent hypersonic requirement outside the laboratory. From almost immediate payoffs in the manned space program on the one hand, X-15's technology sits dormant on the other. The X-15 did, at least, open the door for future hypersonic work, and in so doing sustained interest in manned aircraft at a time when all eyes were turning toward the capsule programs.

b. Unfinished Work. Thanks to the X-15, hypersonic aerodynamics is well advanced. Thanks also to the X-15, the need for additional work in several key "stopper technologies"--areas which pose serious questions for future hypersonic vehicles--is evident. Since the program's abrupt termination in October 1968, the following areas have stood conspicuously in want of a testbed vehicle.

(1) Scramjet Testing. Cruise capability is required of any operational hypersonic vehicle, and despite the advances being

made in laboratories, development of a hypersonic, air-breathing power plant will require a flight-test facility.

(2) Structural Cooling. Hypersonic cruise also requires advanced cooling methods, either active or passive, to dissipate the heat buildup. No existing hypersonic wind tunnel can handle sufficiently large prototype hardware and give reasonably accurate stagnation temperatures.

(3) Aerodynamic Optimization. Despite enhanced ability to do accurate tunnel testing, interference-free testing of aerodynamic shapes can best be done on a hypersonic facility, as envisioned with the replaceable wing tip of the X-15A-2. Validation of proposed designs, such as the delta wing envisioned for the X-15 prior to its termination, ultimately requires flight testing.

(4) Follow-on Projects. Since 1968, more experiments requiring a hypersonic testbed have been added to the list of projects left unfinished. Though referred to by at least one high ranking ASD officer as "the first NHFRF," the X-15 was an ill-suited testbed facility. It had not been designed as such, nor did it provide steady-state flight. It surpassed Mach 6 on only four occasions, the majority of its 199 flights being in the Mach 5 to 5.5 range. Yet what successes it did achieve point to the benefits a well-designed, Mach 6-plus facility could render such fields as hypersonic aerial photography and IR "hot window" studies.

c. Value Of The X-15. The commitment to go ahead with a flight-test program drove mid-1950s near-state-of-the-art technology toward perfection. Designed as a pure research vehicle with no operational prototype encumbrances or requirements for optimum design, the X-15 emerged from a short, three-year developmental program to return almost immediate data on the hypersonic environment. It gave the knowledge needed for today's designs for future hypersonic aircraft. Thanks to the X-15, we are able to do far more valuable laboratory research and testing. In a

way, the X-15 reduced the urgency for a follow-on vehicle since so much more work can now be done with confidence in the wind tunnel, save the ultimate requirement for flight validation.

Thus wrote Ronald Boston with the perception of ten years after the program concluded.

When the X-15 quit flying, NASA was on the verge of initiating the first Phase A Shuttle studies. Yet, even before the X-15 had flown, a team of developers within the Air Force, industry, and NASA were busily at work on what would have been its immediate successor: an ambitious effort to develop an actual orbital hypersonic lifting reentry vehicle called Dyna-Soar.

## NOTES

1. John V. Becker, "Principal Technology Contributions of X-15 Program," (Hampton, VA: NASA Langley Research Center, 8 Oct 1968). Copy in the files of the NASA History Office.
2. Becker, "The X-15 in Retrospect."
3. Ronald G. Boston, "Outline of the X-15's Contributions to Aerospace Technology," (Colorado Springs, CO: USAF Academy, 21 Nov. 1977), pp. 1-15.



CASE II

STRANGLER INFANT: THE  
BOEING X-20A DYNA-SOAR

by

Clarence J. Geiger

## EDITOR'S INTRODUCTION

The X-20 is a particularly poignant case study in the history of hypersonic lifting reentry. No project was ever undertaken with more enthusiasm by its advocates, and no project was ever more callously treated by bureaucratic forces beyond the research and development community. X-20--a shapely hypersonic delta glider--materially advanced understanding of the requirements and the technology needed for lifting reentry vehicles, yet it itself never had the opportunity to demonstrate what it could do.

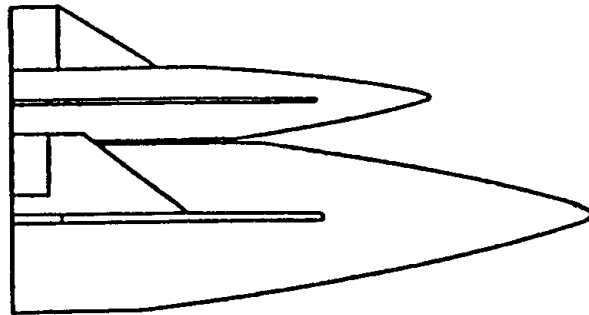
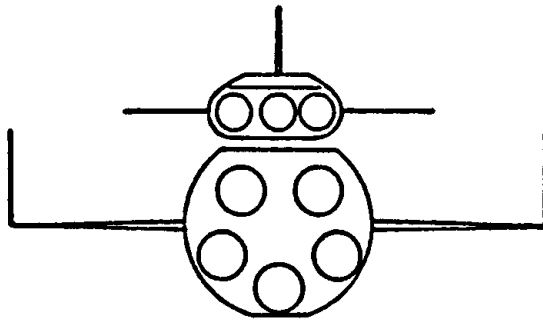
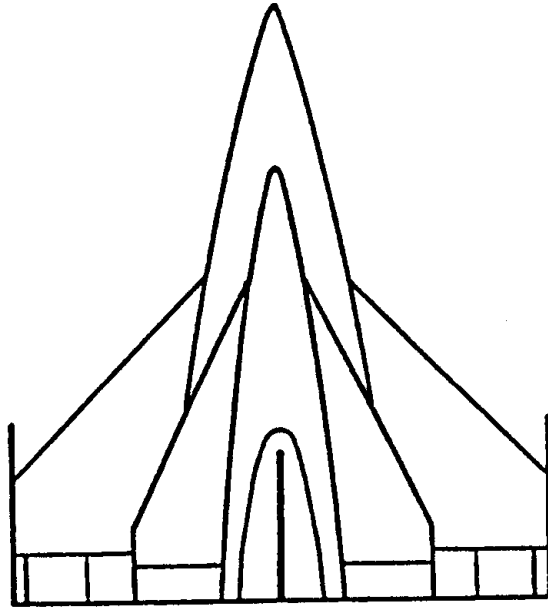
The X-20 program was conceived at Wright-Patterson Air Force Base, with a healthy assist from external organizations including the Bell Aircraft Corporation and the Langley Memorial Aeronautical Laboratory of the National Advisory Committee for Aeronautics (now the Langley Research Center of the National Aeronautics and Space Administration). Its conception coincided with a generalized national interest in hypersonic vehicles for missions ranging from transportation to orbital supply. Even before the X-15 had entered fabrication, devotees of winged reentry were studying a variety of proposals for orbital lifting reentry vehicles, and, indeed, even interplanetary ones. Some of these orbital studies were military in nature, and eventually led into the Dyna-Soar program discussed subsequently. Others were civilian. Most were, in light of subsequent work, completely impractical, if visionary. In August 1952, the Executive Committee of the National Advisory Committee for Aeronautics appointed a hypersonic study group under the chairmanship of Clinton Brown. This body reported to NACA Headquarters in June 1953, recommending that the NACA undertake heating studies, and fire rocket-propelled hypersonic models. It optimistically predicted the near-term development of hypersonic boost-glide intercontinental aircraft. (Most technical studies in



the 1950s suffered from an excess of optimism that the very real problems encountered in designing such craft could be quickly overcome). Even more ambitious and idealistic were the fantastic conceptualizations of Wernher von Braun and Walter Dornberger. Their work naturally drew upon the previous Peenemünde A-4b--A-12 studies. In a series of books published in the early 1950s, A-4b--like and similar craft routinely appeared performing a variety of space missions, usually in the exquisite and seductive paintings of Chesley Bonestell. In 1951, space travel buffs had organized a symposium at the Hayden Planetarium. Out of this enthusiastic meeting came a number of optimistic articles printed in Collier's magazine, and later reprinted in a single volume, Across the Space Frontier. In this work, von Braun described a theoretical three-stage launch vehicle capable of placing 36 tons in earth orbit. The third stage was a canard shuttle-like aircraft having five rocket engines fueled with nitric acid and hydrazine, with provisions for a pilot and crew, and having a retractable landing gear. It spanned 156 feet, with a length of 77 feet. Von Braun predicted that reentry heating would turn the craft cherry-red, but that this could be overcome by using steel. He elaborated upon this concept in a 1956 book, The Exploration of Mars. Here, von Braun and rocket enthusiast Willy Ley conceived constructing a large flying-wing interplanetary spacecraft spanning 450 feet that could coast from earth orbit to Mars, then enter the Martian atmosphere and fly down to a landing. Its nose section was an ascent rocket that would return the crew to Martian orbit preparatory to the return to earth; the rest of the vehicle would be left on the surface of Mars. Von Braun also conceptualized the building of a smaller delta-wing passenger spacecraft that would support earth orbit operations; this craft looked much like an extrapolation of 1950's jet fighters such as the Convair F-102A and Gloster Javelin. Dornberger, meanwhile, had expanded upon his own boost-glide studies. In 1957, in collaboration with Krafft A. Ehrlicke, Dornberger conceived of a two-stage passenger-carrying Shuttle-like transport drawing heavily on Bell's Bomi studies (to be discussed subsequently). (Figure 1).



Figure 1



DORNBERGER-EHRICKE HYPERSONIC TRANSPORT

The stages were mounted in piggyback fashion, with the ventral stage having five rocket engines and the dorsal (passenger-carrying stage) having three. Each stage had delta wings for boost-glide flight. Dornberger and Ehricke anticipated that such a craft would take off with both stages firing and 130 seconds after launch, the lower stage would separate and glide back to land, piloted by its own crew. The smaller dorsal stage would continue onwards, reaching a peak altitude of 27.5 miles and crossing the United States in 75 minutes. Clearly, by the mid-1950s, then, a number of lifting reentry studies were underway, though the practicality of these studies varied widely. What remained to be done was for the industry and government to join forces on a suitable development program that could serve as an actual technology demonstrator.<sup>1</sup>

Already, by 1957, the Ames Aeronautical Laboratory of the NACA had conceived one such likely "beyond X-15" Mach 10 technology demonstrator that would be piloted and air-launched from a Boeing B-36 carrier aircraft for initial trials up to Mach 6. For velocities beyond this, the plane would be launched vertically as the second stage of a two-stage combination, the first stage being a 150,000 lb thrust North American Rocketdyne XLR89-NA-1 engine. Booster separation would occur at 100,000 feet and Mach 6, and the research airplane would then fire up its own XLR99 engine and scoot across the southern United States from Florida to California. Figures 2, 3, and 4 show a schematic view of the research vehicle, its B-36 launch aircraft, and the proposed transcontinental flight path. Interestingly, the Mach 10 design featured a high wing, a sharply swept delta wing with down-turned tips a la the later XB-70A, and would employ a mix of radiative cooling and an internal liquid cooling system. A great debate broke out within the NACA on the merits of high wing vs. flat-bottom low wing, a struggle that low-wing advocates subsequently won. (Ironically, one could "flip" the drawing of the Ames proposal on its back and see a reasonably acceptable flat-bottom hypersonic glider of the sort that occupied so much attention of Air Force, NACA/NASA, and industry studies in the 1950s through the present day). While the Ames Mach 10

Performance:	2-stage; ground launch	1-stage; air launch
Velocity	11,000 ft/sec	5,000 ft/sec
Altitude	135,000 ft	110,000 ft
Range	2,000 N. miles	400 N. miles
Weight:		
Gross weight	110,000 lb	33,000 lb
Weight fuel	90,000 lb	18,000 lb
Weight at burnout	15,000 lb	15,000 lb
Powerplant:	1st stage	2nd stage
Rocket motor	XLR89-NA-1	XLR99-RM-1
Thrust	150,000 lb	57,000 to 17,000 lb

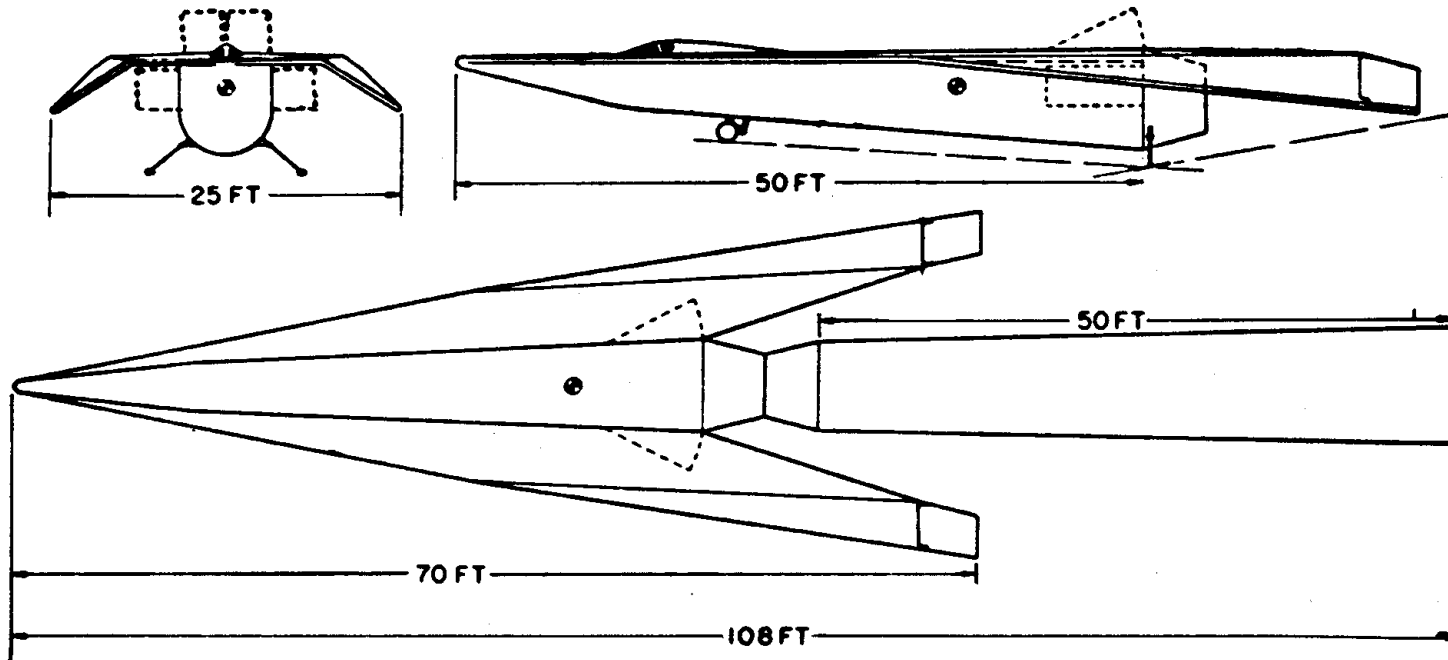
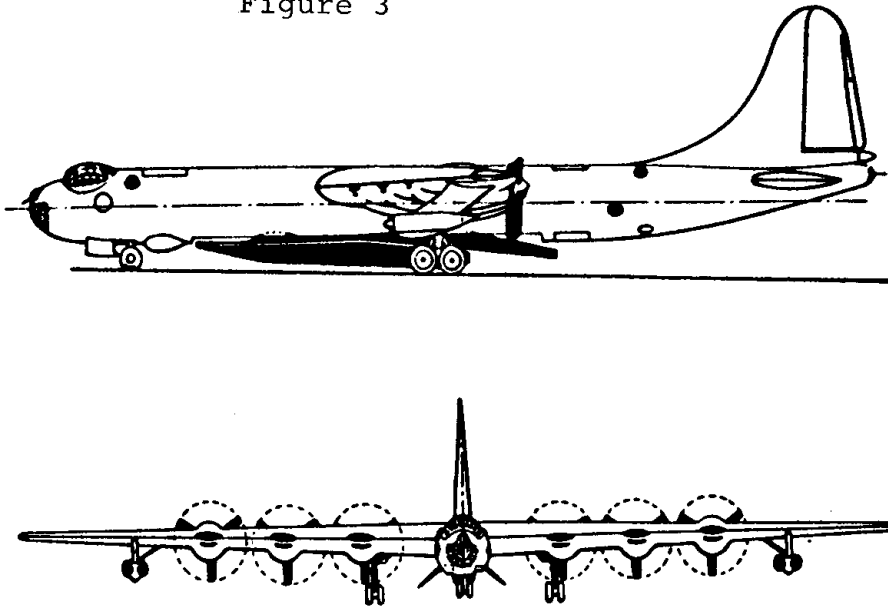


Figure 2

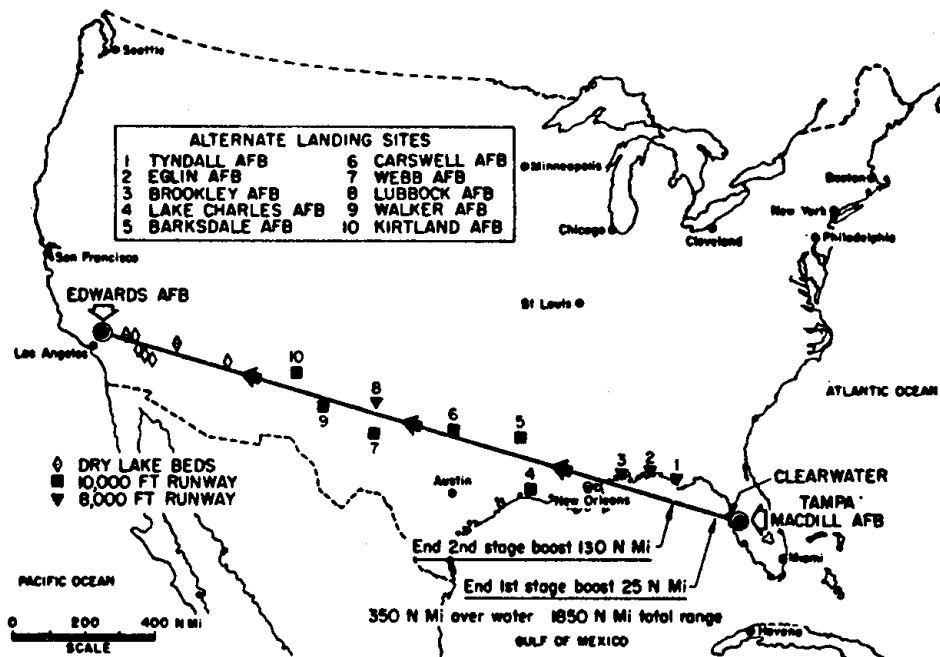


Figure 3



AMES MACH 10 DEMONSTRATOR AND B-36

Figure 4



FLIGHT CORRIDOR FOR AMES MACH 10 DEMONSTRATOR

proposal subsequently went nowhere, it did serve to focus the attention of a major NACA center on one possible hypersonic configuration beyond the X-15, and came at a time when a climate was building that would spawn the cancelled X-20A Dyna-Soar program, the "Round Three" that followed the X-15, and the most ambitious lifting reentry effort prior to the actual Shuttle itself.<sup>2</sup>

Dyna-Soar's origins were nurtured amid this supportive general climate, and specific research and development initiatives undertaken by the Air Force and private industry. In 1952, the Bell Aircraft Corporation had proposed developing a boost-glide bomber-missile dubbed Bomi. With further refinement, Bomi evolved into an intercontinental three-stage "piggyback" reconnaissance bomber similar to later Shuttle "triamese" formulations. William Lamar, a distinguished engineer whose career in military aircraft development dated to the early days of the Second World War, was then in charge of future advanced bomber development studies for the Air Force at Wright-Patterson AFB. He recognized there were several approaches one could take towards future bomber and "recce" development; one, the so-called "vista" (or U-2) approach, envisioned going for maximum altitude in lightly loaded and relatively slow vehicles. Another approach took the other extreme: staying very low and moving very fast (this approach led to consideration of a proposed Mach 3 on-the-deck missile dubbed Pluto). The more reasonable approach, however, lay in extrapolating the already higher-and-faster trend in bomber design, moving from the B-29 to the B-36, the B-47, the B-52, and (by the mid-1950s) the Mach 2 B-58 then undergoing initial flight testing. To Lamar, the advantages of moving beyond the supersonic to a hypersonic strike/recce vehicle were obvious: one got orbital range and virtual invulnerability from interception.<sup>3</sup> At Air Force suggestion, Bell followed Bomi with a two-stage Mach 15 reconnaissance vehicle dubbed System 118P. Both Bomi and System 118P influenced Bell's next design effort, a reconnaissance system dubbed Brass Bell. After evaluating and proving generally receptive to these studies, the Air Force next funded a number of



industry investigations of reconnaissance and strike boost-gliders. In 1956, the Air Force Air Research and Development Command launched a feasibility study of an orbital winged rocket bomber nicknamed Robo. To support Robo and the earlier Brass Bell, the service proposed developing a piloted boost-glide research aircraft known as Hywards. Contractors working with the Air Force on these efforts included Bell, Boeing, Convair, Douglas, North American and Republic. In November 1956, the Air Force asked the NACA to review the service's boost-glide aircraft studies. In response, NACA Director Hugh L. Dryden formed a "Round Three" (Round One being the early X-series and Round Two the X-15) steering committee which evaluated the various projects and then recommended to the Air Force, in September 1957, that the service sponsor development of a flat-bottom hypersonic delta glider. On October 4, 1957, the Russians launched Sputnik; on October 10, the Air Force consolidated Robo, Brass Bell, and Hywards into a single three-phase research program called Dyna-Soar, for "dynamic soaring," what S<sup>ä</sup>nger had termed skipping reentry. On October 15, a "Round Three" conference opened at NACA's Ames Aeronautical Laboratory, and conferees eventually endorsed the recommendations of the Dryden steering committee. A minority favored a purely ballistic H. Julian Allen-type blunt body design having nonlifting characteristics; this marked the genesis of what eventually evolved into the Mercury spacecraft. Another minority favored development of an Alfred Eggers or Eugene Love lifting-body spacecraft. (Eventually, as the studies of the 1960s clearly reveal, all three paths, ballistic, winged, and lifting body, would be pursued by government and industry enthusiasts). On December 21, 1957, the headquarters of the Air Force's Air Research and Development Command (ARDC) issued System Development Directive 464L for development of Dyna-Soar's first phase, envisioned as a simple delta-wing single-seat boost-glider technology demonstrator.<sup>4</sup>

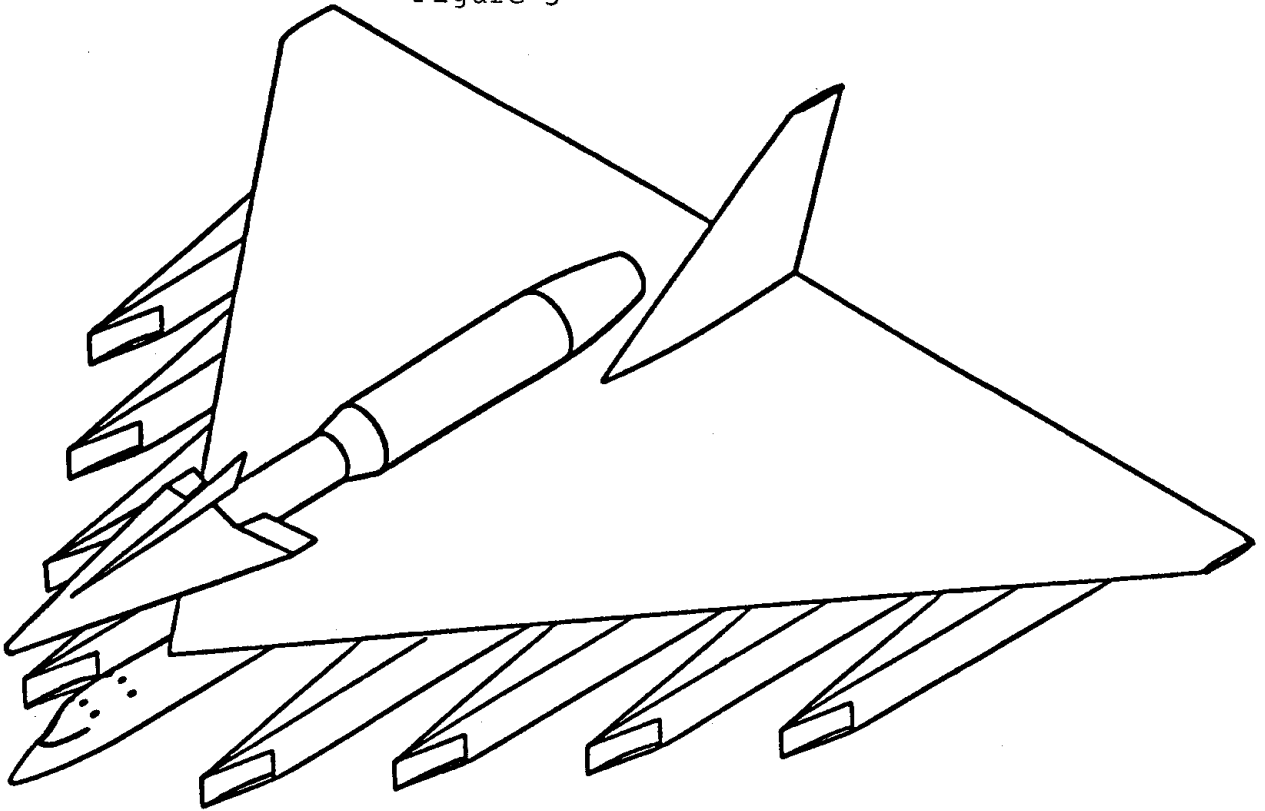
Nine contractor teams eventually responded with proposals, and the respondents represented essentially a Who's Who of American aviation: Bell, Boeing, Chance Vought, Convair, General Electric, Douglas, Lockheed, McDonnell, Martin, North American, Northrop, Republic, and Western Electric. After review, four of the nine were selected to work as two teams: a Martin-Bell team, and a Boeing-Vought team. The Air Force directed Boeing-Vought and Martin-Bell to proceed with additional detailed studies, and, as a result, declared Boeing the winner on November 9, 1959. Martin received a go-ahead to develop the launch booster, a modified Titan ICBM. Bell, the firm whose work had inspired much of the program, wound up with nothing but some subcontracts.\* The Air Force selected Lamar to run the program for the service; his NACA/NASA counterpart was John V. Becker, a distinguished physicist and the "father" of the X-15. Two better individuals could not have been selected, and they worked superbly together.<sup>5</sup>

For a brief while, Dyna-Soar went through some major convolutions involving its external shape, including a brief fling with one configuration having ventral fins and an angularity of design that suggested the fantastic 1930's science fiction of Buck Rogers and Flash Gordon. One of these early schemes is shown in Figure 5--a bizarre eight-engine delta booster lugging the initial Dyna-Soar configuration (consisting of the orbiter and a booster stage) aloft, then firing it into orbit from 75,000 feet. Such grandiose schemes died amidst the need for practical design. Eventually, Dyna-Soar emerged as a radiative-cooled slender delta having a flat Sänger-like bottom, a rounded and tilted nose, and twin end plate vertical fins. (Figure 6). The glider utilized a René 41 nickel superalloy primary structure, a columbium alloy heat shield, a graphite and zirconia nose cap, and molybdenum alloy leading edges. Unfortunately, the program suffered from a

---

\*Eventually, Vought's share of Dyna-Soar involved primarily work on the nose cap. Ironically, Boeing's Dyna-Soar ultimately more closely resembled the original Bell concept than it did Boeing and Vought's winning entry in 1959.

Figure 5

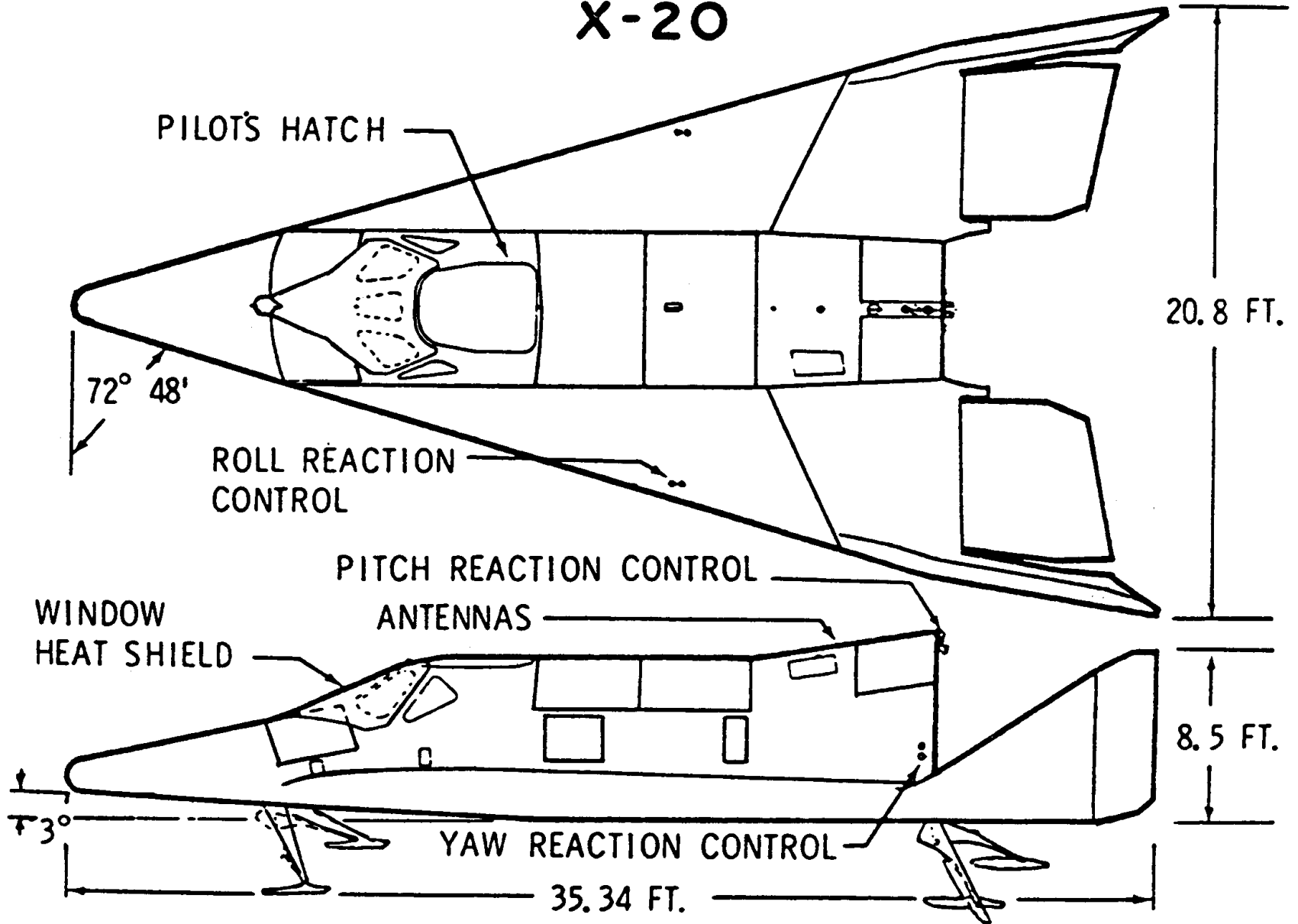


Payload weight:	145,000 lbs.
Launch gross weight:	585,000 lbs.
Booster gross weight:	440,000 lbs.
Booster empty weight:	276,000 lbs.
Launch altitude:	75,000 ft.
Launch velocity:	4,000 ft./sec.

EARLY DYNA-SOAR AIR-LAUNCH CONFIGURATION



# X-20



THE X-20 BOOST GLIDER

Figure 6

perceived (if not actual) lack of clear definition (largely to outsiders) of what its goals should be. At the highest levels within the Air Force, as well as within the prestigious Aerospace Vehicles Panel of the USAF Scientific Advisory Board, disagreements existed over what role Dyna-Soar should play in the steadily growing American manned spacecraft effort. Critics of Dyna-Soar argued that semi-ballistic or ballistic spacecraft (such as growth versions of the planned Gemini spacecraft) could carry a much larger useful payload into orbit. In June 1962, the Air Force designated Dyna-Soar as the X-20A, primarily to emphasize its research function. For a while, X-20A faced sniping criticism from partisans within the USAF Space Systems Division (SSD) favoring development of a rival--a small piloted lifting body for satellite inspection and space logistics known as SAINT II. Though Dyna-Soar weathered this storm while SAINT II itself succumbed, it was clear that Dyna-Soar was losing its appeal. Privately, Secretary of Defense Robert S. McNamara's senior advisors concluded that Dyna-Soar's research objectives could be most expeditiously, safely, and economically met by small reentry models and by the Manned Orbiting Laboratory (MOL) program, a "bluesuit" spin-off of the Gemini program. X-20's support weakened rapidly over the fall of 1963, and McNamara canceled it on December 10, 1963, in favor of proceeding with MOL. (Ironically, MOL itself collapsed subsequently). At the time of its cancellation, the X-20A was about 2½ years and an estimated \$373 million away from its first flight. Four hundred and ten million dollars had already been expended. The cancellation decision is one that is still hotly debated; in any case, Dyna-Soar greatly accelerated progress in hot structures technology, the aerodynamics of delta reentry shapes, hypersonic design theory, and other information directly applicable to the present Shuttle. It was, therefore, a useful exercise despite its termination.<sup>6</sup>

Dyna-Soar's story is a disturbing one, as the following case study shows. Here was a well-thought-out and well-directed program (at least at the USAF and NASA "worker bee" level) that received as

its reward summary execution without fair trial. In the minds of program participants, what is more disturbing are overtones of internal dissension--for example, lukewarm support from Space Systems Division and SSD's technical advisor, the Aerospace Corporation, coupled with lukewarm support from senior levels within the Air Force, including General Bernard Schriever and Lt. Gen. H. M. Estes. "If we could have stuck with von Braun," Lamar recently recalled, "we'd have had it made."<sup>7</sup> At the civilian secretary level within the Department of Defense, X-20 had few supporters; one notable exception was Eugene Zuckert, Secretary of the Air Force. In his last meeting with Secretary of Defense Robert McNamara, Lamar faced a typical "economic" question from Harold Brown: "You want \$1 billion for ten shots: that's \$100 million per shot. What can you do that is worth \$100 million? What can you do that SAMOS can't?"<sup>8</sup> The Secretary of Defense and his immediate staff, with rare exception, turned a blind eye to carefully presented arguments emphasizing the importance of X-20 as a technology demonstrator, and, as a result, after 1962, the outcome was obvious: Dyna-Soar died.

Perhaps Dyna-Soar suffered from the climate of space development in the early 1960s. In 1961, Yuri Gagarin had orbited the earth in a ballistic capsule, and Project Mercury had followed that development approach (though with greater sophistication). One of Dyna-Soar's strongest arguments in the late 1950's was the opportunity it offered to match the Soviets in space and perhaps beat them to a manned orbital flight. A letter from the Deputy Chief of Staff for Development of the Air Force to the Commander of the Air Research and Development Command (the predecessor of today's Air Force Systems Command) stated that:<sup>9</sup>

A manned orbital flight, whether by a glide vehicle or by a minimum altitude satellite essentially outside the earth's atmosphere, is a significant technical milestone in the USAF space program. It is also vital to the prestige of the nation that such a feat be accomplished at the earliest technically

practicable date--if at all possible before the Russians.

The same letter directed continuation of the Air Force-NACA research aircraft partnership "which has proven so productive in earlier programs of the X-airplane series." It also recognized that the technical problems involved in a boost-glide orbital vehicle might necessitate using a ballistic satellite instead in the interests of time and safety. Possibly, once Gagarin had flown and once Mercury stood poised (as it were) on the launch pad, Dyna-Soar lost some psychological support. Then, of course, was the unfortunate acronym "Dyna-Soar:" it stood for dynamic soaring, and made perfect technical sense, but sounded too much like dinosaur: big, complex, slow, and headed for extinction.

Dyna-Soar's cancellation undoubtedly set back the pursuit of lifting reentry technology in the United States by at least a decade. Even if it had never flown an orbital flight, it would have proven a tremendously valuable hypersonic research aircraft follow-on to the X-15, and thus deserved aggressive support within DoD rather than shortsighted cancellation. The following case study was written during and after the cancellation by Dr. Clarence J. Geiger of the then-Historical Division, Information Office, Aeronautical Systems Division. It has been expanded to include a useful analysis of the X-20 work undertaken by the Boeing Company, emphasizing technical accomplishments. The case study offers a particularly good overview of the six critical periods in the development of the X-20: the debate over the nature of the program; the Phase Alpha studies; award of development contracts for the airframe and booster; slippage, rival efforts, and pressure to cancel; the shift to a more defined research focus; and, finally, the continued debate leading to cancellation in December 1963.



## NOTES

1. For Brown study group report, see C. E. Brown, et. al., "A Study of the Problems Relating to High-Speed High-Altitude Flight," (Hampton: NACA Langley Laboratory, June 25, 1953), in the files of the NASA Langley Research Center. Von Braun's conceptual studies are detailed in Willy Ley and Chesley Bonestell's The Conquest of Space (New York: The Viking Press, 1956); Wernher von Braun "Prelude to Space Travel," in Cornelius Ryan, ed., Across the Space Frontier (New York: The Viking Press, 1953), pp. 12-70; Willy Ley and Wernher von Braun, The Exploration of Mars (New York: The Viking Press, 1956). The Dornberger-Ehrlicke project is discussed in Willy Ley's Rockets, Missiles, and Men in Space (New York: The Viking Press, 1968), pp. 449-450. A generally useful introduction to the lifting reentry work of the 1950's is E. P. Smith's "Space Shuttle in Perspective: History in the Making," presented at the XIth Annual Meeting of the American Institute of Aeronautics and Astronautics, Washington, D.C., Feb. 24-26, 1975.
2. Ames laboratory staff, Preliminary Investigation of a New Research Airplane for Exploring the Problems of Efficient Hypersonic Flight (Moffett Field, CA: NACA Ames Aeronautical Laboratory, 18 January 1957), passim. Copy in the files of the History Office, NASA Lyndon B. Johnson Space Center, Houston, Texas.
3. Interview with William Lamar, September 18, 1986.
4. For Dyna-Soar origins, see Clarence J. Geiger, History of the X-20A Dyna-Soar, v. I (Historical Division, Aeronautical Systems Division, Air Force Systems Command, Oct. 1963), pp. ix-x, 4-28; Kleinknecht, "The Rocket Research Airplanes," pp. 209-210; Eugene M. Emme, Aeronautics and Astronautics: An American Chronology of Science and Technology in the Exploration of Space, 1915-1960 (Washington, D.C.: NASA, 1961), pp. 83, 85; the ballistic vs. lifting reentry approach and USAF-NACA relationships on the emerging Dyna-Soar effort is discussed in Loyd S. Swenson, James M. Grimwood, and Charles C. Alexander, This New Ocean: A History of Project Mercury (Washington, D.C.: NASA, 1966), pp. 71, 73-74. See also Robert R. Gilruth, "From Wallops Island to Project Mercury, 1945-1958: A Memoir," in R. Cargill Hall, ed., Essays on the History of Rocketry and Astronautics: Proceedings of the Third Through the Sixth Symposia of the International Academy of Astronautics, v. II (Washington, D.C.: NASA, 1977), pp. 463-465.
5. Geiger, History of the X-20A Dyna-Soar, pp. 29-49; letter from John L. Wesesky to author, Oct. 23, 1985.
6. Ibid., pp. 55-121. Details of the cancellation can be found in Geiger's subsequent History of Aeronautical Systems Division, July-Dec. 1963, v. III, Termination of the X-20A Dyna-Soar (Historical Division, Aeronautical Systems Division, Air Force Systems Command, Sept. 1964), passim. For Congressional and DoD

criticism of the Dyna-Soar program and its impact upon AF planners, see Robert Frank Futrell, Ideas, Concepts, Doctrine: A History of Basic Thinking in the United States Air Force, 1907-1964, v. II (Maxwell AFB: Aerospace Studies Institute, Air University, June 1971), pp. 786, 792-795. The secretarial-level view of the Dyna-Soar cancellation can be found in a memo for the Secretary of Defense from Robert C. Seamans, Jr., and Harold Brown, signed Jan. 29-31, 1964, and in the files of the NASA Johnson Space Center History Office. Finally, Boeing report D2-23418, "Summary of Technical Advances: X-20 Program" (Seattle: The Boeing Company Aerospace Division, July 1964) contains a comprehensive listing of X-20 technical accomplishments, as well as indications of what work remained to be done. I have also benefitted by discussing the cancellation with John V. Becker, chief of hypersonic research for the NASA Langley Research Center, and the major NASA "player" during the Dyna-Soar effort, and Col. Curtis L. Scoville, USAF (ret). One interesting perspective on Dyna-Soar is that of the USAF Scientific Advisory Board; key SAB reports clearly indicate the growing disenchantment and uncertainty affecting the program. See, for example, SAB, "Report of the Aero and Space Vehicles Panel on Dyna-Soar," (Jan. 1960), pp. 1-5; SAB, "Memorandum of the Scientific Advisory Board Aero & Space Vehicles Panel on Dyna-Soar," (Dec. 1960), p. 1; SAB, "Report of the Scientific Advisory Board Aero and Space Vehicles Panel on Dyna-Soar Phase Alpha Review," (Apr. 15, 1960), pp. 1-7; SAB, "Report of the Scientific Advisory Board Aerospace Vehicles Panel," (Nov. 1962), pp. 4-5. Copies of these SAB reports are in the files of the SAB, Hq. USAF, Washington, D.C.

7. Lamar interview.

8. Ibid.

9. Ltr., USAF/CS to ARDC/CC, 31 Jan 1958, copy in the "Hypersonic Aircraft" file, NASA History Office, Washington, D.C.

## CHAPTER I

### BOMI TO DYNA-SOAR

By April of 1945, the Allied drive across Northern Europe had effectively countered Nazi Germany's terror-weapon campaign against the civilian population of Great Britain, Holland, Belgium, and France. The V-1 cruise missile, the so-called "buzz bomb," was largely a thing of past, save for ones air-launched by Heinkel bombers dodging Allied nightfighters over the North Sea. The V-2 ballistic missile likewise was at the end of its military career. The architect of the infamous V-2 and Nazi Germany's missile program, Generalleutnant Walter Dornberger, had taken his emigre band of rocketeers from Peenemünde on the Baltic coast down to the recesses of Bavaria. Now they awaited the arrival of American forces, confident--one might say arrogantly so, given the immense contribution to human suffering that these individuals had made, from the slave labor camp at Nordhausen where V-2s were made to the devastated rubble of London and Antwerp where the missiles had landed--that their services would continue largely uninterrupted in the postwar years. While the V-2 could not have altered the outcome of the war, it had offered a radical vision of future warfare with its dramatic change of the concept of weapon delivery.

At Peenemünde, the V-2 had been antiseptically known as the A-4--the fourth in a series of ever-larger rockets developed by a team led by Dr. Wernher von Braun and Dr. Walter Thiel. Thiel had died in a Royal Air Force bombing raid against the weapons research center in August 1943, and with his death the Nazi rocket team lost their best propulsion expert. The A-4, dubbed V-2 (for Vergeltungswaffe Zwei--"Revenge Weapon Two") by Adolf Hitler, had first struck out at the cities of Europe in September 1944, and

from then until the campaign drew to a close, 3,000 of the supersonic missiles had roared aloft. The Peenemünde team, carefully choosing to turn a blind eye to the pointless frightfulness of the V-2 campaign, constantly chose to see their work leading towards the stars, though they did not let even this vision prevent them from enjoying the success of their labor; "When the first V-2 hit London," von Braun recollected after the war, "the champagne flowed."<sup>1</sup>

There was little reason for champagne in Nazi Germany as 1944 wended its way into 1945, and the developers of the V-2 quickly realized that the loss of coastal launch sites would quickly remove Allied cities from the reach of German terror weapons. In late 1944, drawing upon work dating to 1943, von Braun and Ludwig Roth married the V-2 to a sharply swept low aspect ratio wing, generating a "boost-glide" weapon that could be propelled into the upper atmosphere, transition to wing-borne flight as it reentered, and then glide at supersonic speeds to its target. Eventually, two prototypes, designated the A-4b, flew in early 1945, though only one, launched on January 24, could be considered reasonably successful, and even it broke up during the supersonic glide earthwards.<sup>2</sup> Nevertheless, the first technical seed had been planted.

Independent of the Peenemünde group, Dr. Eugen Sänger and Dr. Irene Sänger-Bredt pursued their own similar studies. By 1944 they had completed their elaborate calculations for a manned rocket bomber. The winged-rocket was to have a length of 92 feet, a span of 50 feet, and a takeoff weight of 110 tons. Unlike von Braun, Sänger preferred horizontal launch to a vertical loft. For 11 seconds, a rocket sled would propel the bomber along tracks, two miles in length, until a takeoff velocity of 1,640 feet per second was attained. Under power of its own rocket engine, the vehicle would then climb to an altitude varying from 30 to 60 miles. At

the end of ascent, the bomber would proceed in an oscillating, gliding flight, conceivably circumnavigating the Earth.

Sänger was intent on explaining the military value of his proposed system and detailed possible modes of attack. To achieve a strike on a specific point, the vehicle would be accelerated only until it acquired enough velocity to reach the target. After releasing its bomb, the vehicle would turn at the lowest possible speed, ignite its engine, and then return to its original base. For greater distances and bomb loads, the possession of an auxiliary landing site near the target was necessary. If such a site were not available, the rocket bomber would have to be sacrificed. An attack on a larger area, however, did not necessitate a low velocity over the target, and, consequently, there was more likelihood that the bomber could circumnavigate the globe.

The drawbacks to Sänger's proposal were obvious, and, consequently, the German military did not give serious consideration to the rocket bomber. The difficulties inherent in turning the rocket bomber at hypersonic speeds only increased the desirability for an antipodal landing site. To depend on the possibility of possessing friendly landing areas so near a target was unrealistic. Even if a fleet of rocket bombers could circle the Earth, a bomb capacity of about 8,000 pounds per vehicle, as estimated by Sänger, could not have changed the course of conflict.<sup>3</sup>

Soviet military officials obtained copies of Sänger's analysis at the end of the war and became interested in the possibilities of boost-glide flight; Stalin even ordered the kidnapping--if it could be arranged--of the Sänger Bredt team. In 1958, an article which appeared in a Soviet aviation journal referred to a Russian glide-bombing system, capable of attaining an altitude of 295,000 feet

and striking a target at a distance of 3,500 nautical miles. While propaganda, it led to an American aviation periodical reporting that Russian scientists were developing an antipodal, glide-missile, designated the T-4A. By March 1960, the Assistant Chief of Staff for Intelligence, USAF headquarters, estimated that the Soviets were at least conducting research directed towards the development of a boost-glide vehicle. Such a system could lead to the development of a craft capable of performing reconnaissance and bombing missions. Air Force intelligence analysts believed that limited flight tests of the manned stage could begin in 1962 and an operational system could be available by 1967. (In any case the first confirmed Soviet work on lifting reentry did not occur until the launch of a subscale lifting body in 1982).<sup>4</sup>

Soon after the war, American military officials also exhibited interest in the possibilities of a boost-glide vehicle. In 1946, the Army Air Force, under a contract with the Douglas Aircraft Company, sheltered a group of American scientists and specialists in various social science areas in an effort to provide analyses and recommendations relating to air warfare. One of the first studies completed under the new Project RAND centered on the design of an orbital vehicle, though of a ballistic; non-lifting design. Basing their analysis on the technological developments of the Peenemünde scientists, RAND experts considered that it was possible, by employing either a four-stage, alcohol-oxygen, or a three-stage, hydrogen-oxygen booster, to place a 500 pound capsule in orbit at an altitude of 300 miles. The initial objective was to provide an orbiting, scientific laboratory, nevertheless, RAND authorities stated that it was feasible to design a capsule with wings for future manned flight.<sup>5</sup> In 1948, RAND made a few more studies investigating the technological difficulties involved in flight beyond the atmosphere; however, the next step was taken by the Bell Aircraft Company.

Dr. von Braun did not become associated with any American efforts in refining the boost-glide concept but, from 1945 through 1950, served as a technical advisor for the Army Ordnance Department at the White Sands Proving Grounds, New Mexico. Dornberger, on the other hand, was held in England for war crimes investigations until 1947 when he became a consultant on guided missiles for the Air Materiel Command at Wright-Patterson Air Force Base, Ohio. In 1950, he left the Air Force and became a consultant for Bell Aircraft. Here, in the fruitful climate of a company that had created the first X-series aircraft, the Nazi missile expert was influential in persuading Bell to undertake a study of boost-glide technology. On April 17, 1952, Bell officials approached Wright Air Development Center (WADC) with a proposal for a manned bomber-missile, abbreviated to Bomi. Bell's glide-vehicle was to be boosted by a two-stage rocket and was to be capable of operating at altitudes above 100,000 feet, at speeds over Mach 4.0, and at a range of 3,000 nautical miles. A month later, Bell submitted a proposal to Wright center for the initiation of a feasibility study. The contractor believed that the study would cost \$398,459 and would take 12 months.<sup>6</sup> Bell's work coincided with Wright's interest in the same field, and triggered a receptive review.

By November 28, the Air Research and Development Command (ARDC) headquarters had completed a review of the Bomi project. While Bell's proposal duplicated parts of the Atlas intercontinental ballistic missile and the Feedback satellite reconnaissance programs, command headquarters considered that some phases of Bomi would advance the Air Force's technical knowledge. Consequently, ARDC headquarters requested WADC to evaluate the proposal with the view of utilizing the concept both as a manned bomber and as a reconnaissance vehicle.<sup>7</sup>

Wright center officials completed their evaluation by April 10, 1953 and listed several reasons for not accepting the

Bell proposal. A range of 3,000 nautical miles was too short for intercontinental operations. It was difficult to conceive how the vehicle could be adequately cooled, nor was there sufficient information concerning stability, control, and aeroelasticity at the proposed speeds. Furthermore, Bell's estimated lift-to-drag ratio was far too optimistic. Since it was to operate under an extreme environment, there was also the question of the value of providing a piloted vehicle. Before undertaking such a project, Wright engineers emphasized that the cost and military worth of such a system first had to be established. Center officials added that some doubt existed concerning the ability of the contractor to complete the program successfully.<sup>8</sup>

Bell Aircraft, however, was persistent, and, on September 22, its representatives briefed ARDC headquarters on the Bomi strategic weapon system. Brigadier General F. B. Wood, Deputy Chief of Staff for Development, did think the proposal "somewhat radical" but stated that it could not be considered "outside the realm of possibilities." General Wood then requested WADC to give further consideration to Bell's proposal.<sup>9</sup> Apparently, Wright center officials reconsidered their first evaluation of Bomi, for, in their reply to ARDC headquarters on November 23, they assumed a more favorable position.

Wright engineers considered that the Atlas ballistic missile and the Navaho cruise missile programs offered more promises of successful development than Bomi. The Bell proposal, however, appeared to present a reconnaissance ability far in advance of the Feedback program. Furthermore, Wright officials reasoned that the Bomi vehicle would provide a test craft for several unexplored flight regimes and would offer a guide for the development of manned, hypersonic, military systems. Because of the lack of information, Wright authorities did not recommend the initiation of development but thought that the potential reconnaissance value of



Bomi necessitated a two-year study program. Specifically, Wright officials recommended that Bell be offered a \$250,000 contract for one year with the possibility of extending the study for an additional year. This investigation should determine whether the piloted Bomi vehicle was more advantageous than an unmanned version and whether a reconnaissance mission would compromise the strategic striking ability of the system.<sup>10</sup>

ARDC headquarters agreed and approved Wright center's recommendation. Brigadier General L. I. Davis, acting Deputy Chief of Staff for Development, emphasized that the strategic requirements for an intercontinental vehicle, with a range up to 25,000 nautical miles, should be considered. General Davis stated that development of a program such as Bomi would not be undertaken until other contractors could offer competitive concepts. In accordance, the acting deputy chief of staff requested that the Boeing Airplane Company include in its efforts for Project MX-2145 (Design Studies for an Advanced Strategic Weapon System) investigations of a manned, glide-rocket system.<sup>11</sup>

Boeing had undertaken MX-2145 in May 1953 in order to determine the characteristics of a high performance bomber which could succeed the B-58 Hustler and be capable of delivering nuclear weapons over intercontinental ranges by 1960. Later, as directed by ARDC headquarters, Boeing briefly considered the possibility of a manned, reconnaissance glide-rocket. The contractor regarded the method of traveling an intermediate distance and then reversing direction to return to the point of origin as impractical. Rather, Boeing emphasized that it would be more feasible to orbit the Earth. The contractor, however, pointed to the difficulties of devising structures to withstand high temperature and equipment for reconnaissance. Yet, because of the military potential of such a system, the contractor thought that further investigations were indicated.<sup>12</sup>

On April 1, 1954, Wright center completed a contract with the Bell Aircraft Corporation for a design study of an advanced, bomber-reconnaissance weapon system. The contractor was to define the various problem areas and detail the requirements for future programs. Bell had to focus on such problems as the necessity for a manned vehicle, the profiles of possible missions, performance at high temperatures, and the feasibility of various guidance systems.<sup>13</sup>

Bell Aircraft now envisaged a three-stage system, with each stage riding pickaback. This system would total more than 800,000 pounds. Bomi, now designated as MX-2276, would be launched vertically, and the three rocket engines would be fired simultaneously, delivering 1.2 million pounds of thrust. Bell proposed manning the booster stage in order to achieve recovery by use of aerodynamic surfaces. The third-stage would also be piloted and would carry navigation, reconnaissance, and bombardment equipment. Bomi would be capable of reaching an altitude of 259,000 feet, attaining a speed of 22,000 feet per second, and possessing a range of 10,600 nautical miles.

The contractor believed that a piloted system such as Bomi held several advantages over an unmanned version. Reliability of the system would be increased, bombing precision augmented, and reconnaissance information easily recovered. Furthermore, operational flexibility would be enhanced with the possibility of selecting alternate targets. Unmanned instrumentation certainly could not provide for all the necessary contingencies.<sup>14</sup>

With the completion of the initial study in May 1955, the contract expired, but Bell continued its efforts without government funds or direction. On June 1, WADC personnel discussed with the contractor the possibility of officially extending its work. The purpose of the Air Force in considering an extension was to

investigate the feasibility of adapting the Bomi concept to Special Reconnaissance System 118P.

On January 4, 1955, ARDC headquarters had issued System Requirement 12, which called for studies of a reconnaissance aircraft or missile possessing a range of 3,000 nautical miles and an operational altitude of more than 100,000 feet. Wright center officials established System 118P, and several contractors investigated the adaptability of boost-glide rockets and vehicles using air-breathing engines to the system requirement. To bring Bell into these efforts, ARDC headquarters gave assurance, in June, that \$125,000 would be released for the purpose of extending Bell's Bomi contract, and by September 21, 1955, contract negotiations were completed. Bell's efforts would continue.<sup>15</sup>

At the request of the Assistant Secretary of the Air Force for Research and Development, Trevor Gardner, personnel from the Bombardment Aircraft Division of ARDC headquarters and Bell Aircraft gave several presentations to ARDC and USAF headquarters in November, where the Bomi concept was received with approval.<sup>16\*</sup> Meanwhile, officials from the laboratories of Wright center, the laboratories of the National Advisory Committee for Aeronautics (NACA), and the Directorate of Weapon Systems in ARDC headquarters had evaluated the results of the Bomi study and had drawn several conclusions.

Representatives from the three organizations thought that Bell's concept was theoretically practicable and promising, and that the Bomi program should be continued to determine the

---

\*On August 1, 1955, the management of weapon system development was transferred from the Wright Air Development Center to ARDC headquarters. Detachment One of the Directorate of Systems Management, which included the Bombardment Aircraft Division, however, was located at Wright-Patterson Air Force Base.

feasibility of such a weapon system. Emphasis, however, should be placed on a test program to validate Bell's analysis. The members considered that the most advantageous procedure for Bomi would be a three-step program with the development of a 5,000 nautical mile, a 10,000 nautical mile, and a global system.<sup>17</sup>

By December 1, 1955, Bell had completed its final engineering report for the supplementary contract and had expended a total of \$420,000 for the Bomi studies. For System 118P, Bell's design had included a two-stage rocket to boost a vehicle to 165,000 feet at a velocity of Mach 15. The contractor, however, was once again out of funds. Brigadier General H. M. Estes, Jr., Assistant Deputy Commander for Weapon Systems, ARDC headquarters, estimated that about \$4 million more would be required for the next 12 to 18 months. General Estes then requested the Deputy Commander for Weapon Systems at ARDC headquarters to allocate \$1 million for fiscal year 1956 and to grant authority for the continuation of the program.<sup>18</sup>

While the question of future funding was being debated, officials from the New Development Weapon Systems Office of ARDC headquarters and Bell Aircraft visited Langley Air Force Base, Virginia, in December 1955, to obtain the views of NACA on the Bomi concept. The advisory committee had first become interested in the boost-glide concept when it undertook a preliminary study in 1953 to determine the feasibility of manned, hypersonic flight. On September 30, 1955, Dr. I. H. Abbott, Assistant Director for Research, NACA, thought that more data was required before a development program could be initiated for Bomi. Dr. Abbott hoped that the Air Force would continue to inform NACA on the future progress of the program in order that its laboratories could contribute to the research program. The conference in December resulted in an invitation to NACA for participation in the validation testing for Bomi.<sup>19</sup>

Early in January 1956, the Intelligence and Reconnaissance Division of ARDC headquarters informed the New Development Weapon Systems Office that \$800,000 had been allocated for continuation of Bomi. The Air Force, however, considered that the Bell program should now be directed towards the fulfillment of the General Operational Requirement 12, which had been issued on May 12, 1955. This directive called for a piloted, high-altitude, reconnaissance weapon system which was to be available by 1959. Accordingly, the Air Force concluded a contract with Bell on March 20, 1956, totalling \$746,500, for Reconnaissance System 459L, commonly known as Brass Bell. In October, the contract was extended to August 31, 1957, bringing total expenditures to approximately \$1 million. Later in 1956, Bell was awarded an additional \$200,000 and four more months to complete its work.<sup>20</sup>

By December 1956, Bell Aircraft had conceived of a manned, two-stage system which would be propelled over 5,500 nautical miles at a velocity of 18,000 feet per second to an altitude of 170,000 feet by Atlas thrust chambers. With the addition of another stage, Bell engineers reasoned that the range could be extended to 10,000 nautical miles with a maximum speed of 22,000 feet per second.<sup>21</sup>

While the Air Force had channeled Bell's work towards the eventual development of a boost-glide, reconnaissance system, it had not abandoned the application of this concept to the development of a bombardment vehicle. On December 19, 1955, the Air Force had sent a request to the aircraft industry for a study which would incorporate analytical investigations, proposed test programs, and design approaches for a manned, hypersonic, rocket-powered, bombardment and reconnaissance weapon system. Boeing, the Republic Aircraft Company, the McDonnell Aircraft Corporation, the Convair Division of the General Dynamics Corporation, Douglas, and North American Aviation responded to the request. Study contracts, amounting to \$860,000 were awarded to the latter three for

investigations extending from May through December 1956. Later, the Martin Company, Lockheed Aircraft, and Bell joined in the study. By the end of fiscal year 1957, an additional \$3.2 million was expended by Boeing, Convair, North American, Republic, Douglas, and Bell from their own funds.<sup>22</sup>

On June 12, 1956, ARDC headquarters outlined the conditions for the rocket-bomber study, now designated as Robo, in its System Requirement 126. The purpose of the study was to determine the feasibility of a manned, hypersonic, bombardment and reconnaissance system for intercontinental operation by 1965. The main requirement of the proposed system was the ability to circumnavigate the globe and yet operate at a minimum altitude of 100,000 feet. Furthermore, the vehicle would not only have to perform strategic strike missions but, in addition, fulfill a reconnaissance role. The contractors would also have to determine the effects of carrying weapons, ranging in weight from 1,500 to 25,000 pounds, on vehicle design and investigate the feasibility of launching air-to-surface missiles.<sup>23</sup>

The importance of advanced systems such as Brass Bell and Robo was given added emphasis by ARDC commander, Lieutenant General T. S. Power, at his conference on "radical" configurations, held on February 15, 1956. General Power stated that the Air Force should stop considering new and novel configurations and should start developing them. Speeds to any conceivable extent and operation of manned, ballistic rockets beyond the atmosphere should be investigated.<sup>24</sup>

Encouraged by General Power's statement, Major G. D. Colchagoff of the Research and Target Systems Division, ARDC headquarters, considered that one of the promising proposed programs was the manned, glide-rocket, research system. This was to be a vehicle similar to Brass Bell and Robo and would be used to obtain

scientific data rather than to fulfill a military role. The research and target division prepared an abbreviated development plan for the test system and submitted it to Air Force headquarters in March. On June 29, headquarters approved the proposal but requested a full development plan.<sup>25</sup> Research and target managers, however, had already encountered funding difficulties.

In April 1956, the research and target division had estimated that \$4 million was required for the manned glide-rocket, and a total of \$33.7 million was needed for the research-vehicle programs, which included the X-13, the X-14, the XB-47D, the X-15, and a vertical-takeoff-and-landing (VTOL) aircraft. Air Force headquarters, however, had set a ceiling of \$8.5 million for all of these programs. The research and target division then undertook negotiations with the Air Materiel Command to determine a method of funding to alleviate this deficiency. If this attempt failed, the division warned USAF headquarters that the Air Force would not have a research-vehicle program.<sup>26</sup>

Air Force headquarters, however, drastically reduced the budget for fiscal year 1957, allocating no funds for the manned glide-rocket. General Power warned that this reduction would postpone his bold research program for at least one year. He cautioned headquarters that this action would seriously jeopardize America's qualitative lead over Russia.<sup>27</sup>

In spite of inadequate funding, ARDC issued System Requirement 131 on November 6, 1956, which requested information from the ARDC director of systems management, Wright center, the flight test center and the Cambridge research center for the preparation of an abbreviated system development plan. The manned, glide-rocket, research program was now titled Hypersonic Weapons Research and Development Supporting System (Hywards) and was classified as System 455L. By December 28, the ARDC Directorate of Systems Plans had completed a development plan for Hywards.<sup>28</sup>

The purpose of the Hywards vehicle was to provide research data on aerodynamic, structural, human factor, and component problems and was to serve as a test craft for development of subsystems to be employed in future boost-glide systems. The research and target division considered three propulsion choices as satisfactory for boosting Hywards. The 35,000 pound thrust chambers, employing fluorine-ammonia fuel, which Bell had under development, was one possibility. The 55,500 and 60,000 pound thrust sustainer engines for the Atlas and Titan systems comprised another. The 50,000 pound thrust XLR-99 engine, employed in the X-15 vehicle, was the third option. One of these rocket systems would propel the Hywards craft to a velocity of 12,000 feet per second and an altitude of 360,000 feet. The initial flight test program was to employ the air-drop technique, similar to the X-15 launch, while later testing would use a rocket-boosted, ground-launch method. The research and target division emphasized that by appropriate modifications to Hywards, increased velocities and orbital flight could be attained to provide continuing test support for the Air Force's technological advances.<sup>29</sup>

On February 27, 1957, the development plans for both Hywards and Brass Bell were presented to USAF headquarters, where it was decided that the two programs were complementary and, therefore, should be consolidated. Funding, however, proved more difficult. For fiscal year 1958, ARDC headquarters had requested \$5 million for Hywards and \$4.5 million for Brass Bell. Air Force headquarters, however, reduced these requests to a total of \$5.5 million. Lieutenant General D. L. Putt, Deputy Chief of Staff for Development, USAF headquarters, hesitated endorsing the boost-glide programs. The lack of Air Force funds necessitated giving priority to the advanced satellite reconnaissance system, 117L, rather than to Hywards or Brass Bell. Furthermore, the X-15 program would provide a more dependable source of research data than the boost-glide programs. Major General R. P. Swofford,



Director of Research and Development, USAF headquarters, did recommend that \$1 million be allocated for the boost-glide systems, but, on April 30, Air Force headquarters informed ARDC headquarters that the two development plans were disapproved and that a new plan, encompassing all hypersonic weapon systems, should be prepared.<sup>30</sup>

Before the new development plan for Brass Bell and Hywards was completed, additional investigations for the Robo program were accomplished. On June 20, 1957, an ad hoc committee consisting of representatives from ARDC headquarters, Wright Air Development Center, the Cambridge Air Force Research Center, and the Air Materiel Command, was formed to evaluate the Robo studies of the contractors. Advisory personnel from the Strategic Air Command, the National Advisory Committee for Aeronautics, and the Office of Scientific Research were also present.

During the first three days of the conference, the contractors working on System Requirement 126 presented their proposals, most of which centered on the feasibility of manned vehicles. Both Bell and Douglas favored a three-stage, boost-glide vehicle, the former employing fluorine and the latter, an oxygen propellant. The Convair Division also proposed a three-stage system, using fluorine fuel, but its concept differed from the previous two in that a control rocket and turbojet engine were placed in the glider. While North American advanced a two-stage vehicle, using conventional rocket fuel, Republic advocated an unmanned vehicle, powered by a hypersonic cruise, ramjet engine, and boosted by a single-stage rocket. Republic's proposal also involved an unmanned satellite, guidance station, which was to be placed in orbit by a three-stage booster. Finally, Boeing favored an unmanned version and advanced an intercontinental glide-missile. In the opinion of Boeing officials, a manned vehicle would involve a longer development cycle and would not possess any great advantage over a missile.

After the presentation of the contractor's proposals, the committee spent the next two days evaluating the concepts. While Wright officials thought that the boost-glide concept was feasible and would offer the promise of an operational weapon system by 1970, they also pointed to several problems confronting the Air Force. The details of configuration design were yet unknown. The status of research in the area of materials was not sufficiently advanced. Lack of hypersonic test facilities would delay ramjet development until 1962. Rocket engines were not reliable enough to allow an adequate safety factor for manned vehicles during launch. Finally, center officials pointed to the difficulty of providing a suitable physiological environment for a piloted craft.

Officials of the Cambridge Research Center focused on a different set of problems. All the proposals employed an inertial, autonavigating system, and Cambridge officials pointed out that these systems required detailed gravitational and geodetical information in order to strike a target accurately. The effect of the Earth's rotational motion became extremely important at hypersonic speeds, and, consequently, this factor would have to be considered in determining the accuracy of the guidance systems. Research center scientists also emphasized that an ion sheath would be created as the vehicle penetrated the atmosphere during reentry; this phenomenon would hinder communication. There were other difficulties that required investigation. The thermal properties of the atmosphere would have to be studied in order to determine the extent of aerodynamic heating. Adequate data on the effect of wind turbulence and the impact of meteor dust on the vehicle would have to be determined. Officials of the Cambridge center added one more problem: the presence of ionization trails, infrared radiation, and vehicle contrails could facilitate hostile detection of the vehicle.

It was apparent to the representatives of the Air Materiel Command that the development of either a manned or unmanned system

would be feasible only with increased and coordinated efforts of six to eight years of basic research. More detailed knowledge was required of the system design in order that a determination could be made of various logistical problems and the complexity of the launching area. Viewing the development costs for the ballistic missile programs, materiel officials estimated that the cost for Robo would be extremely high. In order that the Robo program could be continued, air materiel officials recommended that the participating contractors be given specific research projects. A contracting source for the conceptual vehicle should then be chosen, and, after approximately six years, competition for the weapon system development should be held.

After surveying the contractors' proposals and the analyses of Wright center, the materiel command, and the Cambridge center, the ad hoc committee concluded that a boost-glide weapon system was technically feasible, in spite of the numerous problems inherent in the development of such a system. With moderate funding, an experimental vehicle could be tested in 1965, a glide-missile in 1968, and Robo in 1974. The committee emphasized that the promise of boost-glide vehicles to be employed either for scientific research or as weapon systems was necessity enough for the undertaking. The members of the committee went beyond the scope of the Robo proposals and recommended that ARDC headquarters submit a preliminary development plan to USAF headquarters, covering the entire complex of boost-glide vehicles.<sup>31</sup>

By October 10, 1957, the Director of Systems Plans, ARDC headquarters, had completed consolidating the details of the Hywards, Brass Bell, and Robo programs into a three-step, abbreviated, development plan for the new Dyna-Soar (a compound of dynamic soaring) program. Like Hywards, the first phase of System 464L involved the development of a manned, hypersonic, test vehicle which would obtain data in a flight regime significantly beyond the

reach of the X-15 and would provide a means to evaluate military subsystems. To avoid further confusion between the purpose of Dyna-Soar and the X-15 vehicle, the directorate made a clear distinction between a research vehicle and a conceptual test vehicle. Both vehicles were designed to obtain flight data in a regime which had not been sufficiently well defined; however, the latter was to obtain information for the development of a specific system. The initial objectives of the Step I vehicle would be a speed of approximately 18,000 feet per second and altitudes of 350,000 feet and would be attained by use of one of the three engines considered for Hywards.

The Brass Bell program assumed the position of Step II in the Dyna-Soar plan. A two-stage rocket booster would propel the reconnaissance vehicle to a speed of 18,000 feet per second and an altitude of about 170,000 feet. The vehicle would then glide over a range of 5,000 nautical miles. The system would have to be capable of providing high quality photographic, radar, and intelligence information. The vehicle would also have to possess the ability of performing strategic bombing missions. The Director of Systems Plans considered that the liquid rocket Titan sustainer appeared usable; however, investigations under Step I could prove the fluorine engine more valuable.

Step III incorporated the Robo plans, and encompassed a more sophisticated vehicle which would be boosted to 300,000 feet and 25,000 feet per second and would be capable of orbital flight. Like the earlier phase, this vehicle would be able to execute bombardment or reconnaissance missions.

Because of insufficient data, the directorate reasoned that the Dyna-Soar program could not be immediately initiated. A two-phase program for preliminary investigations had to come first. Phase one would involve validation of various assumptions, theory, and

data gathered from previous boost-glide studies, provide design data, and determine the optimum flight profile for the conceptual vehicle. The second part would refine vehicle design, establish performance, and define subsystems and research instrumentation. While this two-phase preliminary program would consume 12 to 18 months, preliminary studies for the Brass Bell and Robo phases of Dyna-Soar could be started. Following this procedure, flight testing at near satellite speeds for the conceptual test vehicle would begin in 1966. The estimated operational date for Dyna-Soar II was set in 1969, and for Dyna-Soar III in 1974.

The Director of Systems Plans argued that the hypersonic, boost-glide vehicle offered a considerable extension of speed, range, and altitude over conventional Air Force systems. Furthermore, this concept represented a major step towards manned space flight. It could not be safely assumed, the systems plans directorate reasoned, that the intercontinental ballistic missile would destroy all the required targets in the decade of the 1970s. Difficulties in penetrating hostile territory by air-breathing vehicles further enhanced the necessity for a manned, boost-glide vehicle. Additionally, the proposed reconnaissance ability of Dyna-Soar could provide more detailed and accurate intelligence data than other Air Force reconnaissance systems then under development. The director warned that time could not be economically bought. If the boost-glide weapon system were necessary, it was imperative to initiate the Dyna-Soar program by allowing a funding level of \$3 million for fiscal year 1958.<sup>32</sup>

On October 17, 1957, Lieutenant Colonel C. G. Strathy of the Research and Target Systems Division presented the Dyna-Soar plan to Air Force headquarters. Brigadier General D. Z. Zimmerman, Deputy Director of Development Planning, USAF headquarters, gave enthusiastic endorsement but thought that ARDC headquarters should take a more courageous approach. Command headquarters, he stated,

should immediately consider what could be accomplished with greater funding than had been requested. Also present at the briefing was Dr. J. W. Crowley, Associate Director for Research of NACA. He pointed out that the national advisory committee was strongly in favor of initiating the conceptual vehicle program as a logical extension of the X-15 program. He emphasized that his organization was directing its research towards the refinement of the boost-glide concept and was planning new facilities for future research.<sup>33</sup>

Brigadier General H. A. Boushey, Deputy Director of Research and Development, USAF headquarters, informed ARDC headquarters, on November 15, that the Dyna-Soar abbreviated development plan had been approved. General Boushey's office then issued, on November 25, Development Directive 94, which allocated \$3 million of fiscal year 1958 funds for the hypersonic, glide-rocket weapon system. The boost-glide concept offered the promise of a rapid extension of the manned flight regime, and following General Zimmerman's reasoning, the deputy director stated that the philosophy of minimum risk and minimum rate of expenditure must be abandoned. If the concept appeared feasible after expenditure of fiscal year 1958 and 1959 funds, the boost-glide program should definitely be accelerated. Not certain of the feasibility of piloted flight, Air Force headquarters directed that the study of manned and unmanned reconnaissance and bombardment weapon systems should be pursued with equal determination. A decision on whether the vehicle was to be piloted would be made in the future and based on substantial analysis. Finally, USAF headquarters stressed that the only objective of the conceptual test vehicle was to obtain data on the boost-glide flight regime. Early and clear test results from this system must be obtained.<sup>34</sup> Thus, by the end of 1957, the Air Force had advanced the field of hypersonic boost-glide studies towards a clearly delineated development program for an orbital, military vehicle--Dyna-Soar.

## NOTES

1. W. R. Dornberger, V-2 (New York: The Viking Press, 1954), p. 268; W. F. Craven and J. L. Cate (eds.), The Army Air Forces in World War II, Vol. III: Europe: Argument to V-E Day, January 1944 to May 1945 (Chicago: The University of Chicago Press, 1951), p. 542.
2. Dornberger, V-2, pp. 140-143, 250-251, 271.
3. Col. L. E. Simon, Report of German Scientific Establishments (Washington: U.S. Army, 1945), pp. 156-158, 200-201; Drs. Eugen Sänger and Irene Bredt, A Rocket Drive for Long Range Bombers (Santa Barbara, Calif.: Robert Cornog, 1952), pp. 6, 50-51, 58, 85, 122, 129, 136-138; Willy Ley, Rockets, Missiles, and Space Travel (2d. ed. rev., New York: The Viking Press, 1961), pp. 4, 8-10, 429-434.
4. Ley, Rockets, Missiles, and Space Travel, pp. 429-430; Missiles and Rockets, 11 Jan. 1960, p. 13; ltr., Col. J. F. Berry, Dep. Dir., Warning and Threat Assessments Ofc., ACS/Intel., Hqs. USAF to Dir., Adv. Tech., DCS/Dev., Hqs. USAF, 18 Mar. 1960, subj.: Estimate of USSR Boost-Glide Activity.
5. Douglas Aircraft Company, Preliminary Design of an Experimental World-Circling Spaceship (Santa Monica, Calif.: Douglas Aircraft Co., 1946), pp. ii-viii, 192-193, 203, 211.
6. Ltr., R. J. Sandstrom, Vice Pres. of Engg., Bell Aircraft Corp. to Hqs. WADC, 17 Apr. 1952, subj.: Proposed Glide Bomber Study; ltr., J. W. Rane, Jr., Asst. Dir./Contracts, WADC, 26 May 1952, subj.: Rocket Bomber Development Program--Proposal for Feasibility Study.
7. Ltr., Lt. Col. H. Heaton, Acting Dir., Aero & Propul. Ofc., Dep/Dev., Hqs. ARDC to Hqs. WADC, 28 Nov. 1952, subj.: Rocket Bomber Feasibility Studies.
8. Ltr., Hqs. WADC to Hqs. ARDC, 10 Apr. 1953, subj.: Rocket Bomber Feasibility.
9. Ltr., Brig. Gen. F. B. Wood, DCS/Dev., Hqs. ARDC to Hqs. WADC, 1 Oct. 1953, subj.: Bell Aircraft Corporation Strategic Weapon System D-143 Bomi.
10. Ltr., Col. M. C. Demler, Vice Cmdr., WADC to Cmdr., ARDC, 23 Nov. 1953, subj.: Bell Aircraft Corporation Strategic Weapon System D-143 Bomi.
11. Ltr., Brig. Gen. L. I. Davis, Acting DCS/Dev., Hqs. ARDC to Hqs. WADC, 23 Dec. 1953, subj.: Bell Aircraft Corporation Strategic Weapon System D-143 Bomi.

12. Rpt., Boeing Airplane Company, 22 Apr. 1954, subj.: Preliminary Study of Design Characteristics of Hypersonic Bombardment Rockets, pp. 24-26; rpt., Boeing, 1 July 1953, subj.: Planning Report, pp. 1-2; History of Wright Air Development Center, 1 July - 31 December 1953, II, 275-277.
13. C. H. Uyehara, Dyna-Soar Antecedents (unpublished manuscript, ASD Hist. Div. files, 1960), p. 14.
14. Ibid., pp. 14, 19, 22.
15. Directorate of Systems Management Weekly Activity Report, 7 and 14 June 1955, 22 Sept. 1955, hereafter cited as DSM WAR.
16. DSM WAR, 25 Nov. 1955, 15 Dec. 1955.
17. Ltr., Brig. Gen. H. M. Estes, Jr., Asst. Dep. Cmdr/Weap. Sys., Hqs. ARDC to Dep. Cmdr/Weap. Sys., Hqs. ARDC, 21 Dec. 1955, subj.: Evaluation of Project Bomi.
18. Ibid.; DSM WAR, 15 Dec. 1955, 5 Apr. 1956.
19. Ltr., Dr. I. R. Abbott, Asst. Dir/Res., NACA to Hqs. WADC, 30 Sept. 1955, subj.: Requested Comments on Project MX-2276; DSM WAR, 22 Dec. 1955.
20. GOR 12, Hqs. USAF, 12 May 1955, subj.: Piloted Very High Altitude Reconnaissance Weapon System; DSM WAR, 12 Jan. 1956; Uyehara, Antecedents, pp. 35-36; R&D Proj. Card, System 459L, Intel. & Recon. Sys. Div., Hqs. ARDC, 31 Dec. 1956, subj.: Brass Bell.
21. R&D Proj. Card, System 459L, 31 Dec. 1956, subj.: Brass Bell.
22. Uyehara, Antecedents, pp. 44-45; rpt., Ad Hoc Committee, 1 Aug. 1957, subj.: Evaluation Report for ARDC System Requirement No. 126, Robo.
23. SR 126, Hqs. ARDC, 12 June 1956, subj.: Rocket Bomber Study.
24. Memo., Maj. G. D. Colchagoff, Res. & Target Sys. Div., Dep. Cmdr/Weap. Sys., Hqs. ARDC to Lt. Col. R. C. Anderson, Res. & Target Sys. Div., 16 Feb. 1956, subj.: New Research Systems.
25. Ibid.; Uyehara, Antecedents, p. 51.
26. Memo., Res. & Target Sys. Div., Hqs. ARDC, 16 Apr. 1956, subj.: Research Vehicle Program.
27. Ltr., Lt. Gen. T. S. Powers, Cmdr., ARDC to Hqs. USAF, 16 July.



28. SR 131, Hqs. ARDC, 6 Nov. 1956; Chronology, DSM, Hqs. ARDC, 14 Mar. 1959, subj.: Significant Events, Dyna-Soar Background, p. 15.
29. R&D Proj. Card, System 455L, Res. & Target Sys. Div., Hqs. ARDC, 28 Dec. 1956, subj.: Hypersonic Glide Rocket Research System.
30. Uyehara, Antecedents, pp. 55-56, 57.
31. Rpt., Ad Hoc Committee, 1 Aug. 1957, subj.: Evaluation Report of the Ad Hoc Committee for ARDC System Requirement Number 126, Robo; rpt., Ad Hoc Committee, 1 Oct. 1957, subj.: Supplement 1 to the Evaluation Report.
32. Abbreviated System Development Plan, System 464L, Hqs. ARDC, 10 Oct. 1957, subj.: Hypersonic Strategic Weapon System.
33. Trip rpt., Lt. W. C. Walter, New Dev. Weap. Sys. Ofc., Hqs. ARDC to R. D. Hodge, Ch., New Dev. Weap. Sys. Ofc., 21 Oct. 1957, subj.: Visit to Hqs. USAF on Project Dyna-Soar; ltr., Brig. Gen. H. A. Boushey, Dep. Dir., Res. & Dev., DCS/Dev., Hqs. USAF to Cmdr., ARDC, 15 Nov. 1957, subj.: Approval of Abbreviated Development Plan for System 464L.
34. DD 94, Hqs. USAF, 25 Nov. 1957, subj.: Hypersonic Glide Rocket Weapon System.



## CHAPTER II

### SYSTEM 464L

With the approval of the abbreviated development plan, the direction of the Dyna-Soar program appeared clearly marked. An experimental glider, a reconnaissance vehicle, and a bombardment system comprised a three-step progression. During the existence of System 464L, however, officials in the Department of Defense subjected the program to severe criticism. The necessity of orbital flight and the feasibility of a boost-glide weapon system were points frequently questioned. By November 1959, the project office had to undertake an exacting investigation of the Dyna-Soar approach to manned space flight. Certainty of program objectives had momentarily disappeared.

On December 21, 1957, ARDC headquarters issued System Development Directive 464L, which stipulated that the mission of the conceptual test vehicle, Dyna-Soar I, was to obtain data on the boost-glide flight regime in support of future weapon system development. Headquarters suggested that a system development plan for Dyna-Soar I and the recommended weapon system programs be completed on October 31, 1958 and set July 1962 as the date for the first flight of the conceptual test vehicle. Finally, ARDC headquarters approved immediate initiation of the program by directing the source selection process to begin.<sup>1</sup>

By January 25, 1958, a task group of the source selection board had screened a list of 111 contractors to determine potential bidders for the Phase I design. The working group considered that Bell, Boeing, Chance-Vought Aircraft, Convair, General Electric Company, Douglas, Lockheed, Martin, North American, and Western

Electric Company would be able to carry out the development. Later, the list was amended to include McDonnell Aircraft, Northrop Aircraft, and Republic Aviation.<sup>2</sup>

The source selection board had received, by March 1958, proposals from nine contractor teams. Essentially, two approaches were taken in considering the development of Dyna-Soar I. In the satelloid concept, a glider would be boosted to an orbital velocity of 25,500 feet per second to an altitude of 400,000 feet, thereby achieving global range as a satellite. In the flexible boost-glide proposal, however, the projected vehicle would follow a glide-trajectory after expenditure of the booster. With a high lift-to-drag ratio at a velocity of 25,000 feet per second and an altitude of 300,000 feet, the glider could circumnavigate the Earth.

Three contractors offered the first approach, the satelloid concept, as the most feasible. Republic conceived of a 16,000 pound delta-wing glider boosted by three solid propellant stages. The vehicle, along with a 6,450 pound space-to-earth missile, would be propelled to a velocity of 25,700 feet per second and an altitude of 400,000 feet. Lockheed considered a 5,000 pound glider similar in design to that of Republic. This vehicle could operate as a satelloid, however, the contractor suggested a modified Atlas booster which lacked sufficient thrust for global range. A 15,000 pound vehicle similar to the X-15 craft comprised the proposal of North American. The booster was to consist of a one-and-a-half stage liquid propellant unit with an additional stage in the glider. Operated by a two-man crew, the vehicle was also to have two small liquid engines for maneuvering and landing. The glider was to be propelled to a velocity of 25,600 feet per second and an altitude of 400,000 feet and would operate as a satelloid.

Six contractors concentrated on the flexible boost-glide concept. Douglas considered a 13,000 pound arrow-wing glider which

was to be boosted by three modified solid propellant stages of the Minuteman system. An additional stage would provide a booster for advanced versions of Dyna-Soar. McDonnell offered a design similar to that of Douglas but proposed, instead, the employment of a modified Atlas unit. A delta-wing glider, weighing 11,300 pounds, was recommended by Convair. This contractor did not consider the various possibilities for the booster system but did incorporate a turbojet engine to facilitate landing maneuvers. Martin and Bell joined to propose a two-man delta-wing vehicle weighing 13,300 pounds, which would be propelled by a modified Titan engine. Employing Minuteman solid propellant units, Boeing offered a smaller glider, weighing 6,500 pounds. Finally, Northrop proposed a 14,200 pound delta-wing glider which was to be boosted by a combination liquid and solid propellant engine.

The task group of the source selection board, after reviewing the proposals, pointed out that with the exception of the North American vehicle all of the contractors' proposed configurations were based on a delta-wing design. The size of the proposed vehicles was also small in comparison with current fighter aircraft such as the F-106. McDonnell and Republic offered vehicles which could carry the biggest payload, yet they in turn required the largest boosters. At the other extreme was Boeing's proposal which could carry only 500 pounds, including the weight of the pilot. The task group also emphasized that of the three contractors proposing the satelloid concept Lockheed's vehicle fell short of a global range. Of the six contractors offering the flexible boost-glide approach, only the Martin-Bell team and Boeing proposed a first-step vehicle capable of achieving orbital velocities. The other four considered a global range in advanced versions.<sup>3</sup>

By the beginning of April, the working group had completed its evaluation of the contractors' proposals, and, on June 16, 1958, Air Force headquarters announced that the Martin Company and the

Boeing Airplane Company both had been selected for the development of Dyna-Soar I.<sup>4</sup> Major General R. P. Swofford, Jr., then Acting Deputy Chief of Staff for Development, USAF headquarters, clarified the selection of two contractors. A competitive period between Martin and Boeing would extend from 12 to 18 months at which time selection of a single contractor would be made. General Swofford anticipated that \$3 million would be available from fiscal year 1958 funds and \$15 million would be set for 1959. The decision as to whether Dyna-Soar I would operate as a boost-glide or a satelloid system was left open, as well as the determination of a piloted or unmanned system. The acting deputy directed that both contractors should proceed as far as possible with available funds towards the completion of an experimental test vehicle. The design, however, should approximate the configuration of a Dyna-Soar weapon system.<sup>5</sup>

Apparently some questioning concerning the validity of the Dyna-Soar program occurred at Air Force headquarters, for, on July 11, Major General J. W. Sessums, Jr., Vice Commander of ARDC, stated to Lieutenant General R. C. Wilson, USAF Deputy Chief of Staff for Development, that Air Staff personnel should stop doubting the necessity for Dyna-Soar. Once a new project had been sanctioned by headquarters, General Sessums considered, support should be given for its completion.<sup>6</sup> In reply, General Wilson assured General Sessums that the Air Staff held the conviction that Dyna-Soar was an important project. However, due to the interest of the Advanced Research Projects Agency (ARPA) and the National Aeronautics and Space Administration (NASA) and their undetermined responsibilities in the development of systems such as Dyna-Soar,

the Air Force firmly had to defend its projects to the Department of Defense.<sup>7\*</sup> General Wilson closed by reassuring General Sessums of his full endorsement of the Dyna-Soar program.<sup>8</sup>

While the Dyna-Soar program had the verbal support of USAF headquarters, Lieutenant General S. E. Anderson, ARDC commander, considered that the program required additional funds. He reminded General Wilson that ARDC headquarters, with the efforts of only one contractor in mind, had requested \$32.5 million for fiscal year 1959. The Air Staff had limited this amount to \$15 million for the contributions of both Boeing and Martin. Consequently, \$52 million was now required for the 1959 Dyna-Soar program. The ARDC commander emphasized that if System 464L were to represent a major step in manned space flight, then the delay inherent in the reduced funding must be recognized and accepted by Air Force headquarters.<sup>9</sup> General Wilson agreed with General Anderson's estimation and stated that the approved funding level for fiscal year 1959 would undoubtedly delay the program by one year. The stipulated \$18 million for both fiscal years 1958 and 1959, although a minimum amount, would permit the final contractor selection. General Wilson did assure the ARDC commander that the

---

\*Previously, considerable discussion within the Air Force had taken place concerning the role which the National Aeronautics and Space Administration, earlier designated the National Advisory Committee for Aeronautics, was going to play in the Dyna-Soar program. On January 31, 1958, Lieutenant General D. L. Putt, Deputy Chief of Staff for Development, USAF headquarters, asked NACA to join with the Air Force in developing a manned, orbiting, research vehicle. He further stated that the program should be managed and funded along the lines of the X-15 program. It appeared that General Putt was proposing a Dyna-Soar I program under the direction of NACA. ARDC headquarters strongly recommended against this contingency on the grounds that Dyna-Soar would eventually be directed towards a weapon system development. By May 20, General T. D. White, Air Force Chief of Staff, and Dr. H. L. Dryden, NACA director, signed an agreement for NACA participation in System 464L. With the technical advice and assistance of NACA, the Air Force would direct and fund Dyna-Soar development. On November 14, 1958, the Air Force and NASA reaffirmed this agreement.

Air Staff would try to alleviate the situation and thought there was a possibility for increasing fiscal year 1959 funding.<sup>10</sup>

Major General V. R. Haugen, Assistant Deputy Commander for Weapon Systems, Detachment One, made another plea to the Deputy Chief of Staff for Development. He estimated that inadequate funding would push the flight date for the research vehicle back by eight months. Such austerity would hinder the developmental test program and cause excessive design modification. General Haugen strongly urged the augmentation of fiscal year 1959 funding to \$52 million. Besides this, it was important that the full release of the planned \$15 million be immediately made.<sup>11</sup>

On September 4, Colonel J. L. Martin, Jr., Acting Director of Advanced Technology, USAF headquarters, offered additional clarification of the funding situation to Detachment One. He stated that the two separate efforts by Boeing and Martin should only be maintained until study results pointed to a single, superior approach. It was possible for this effort to be terminated within 12 months. Colonel Martin pointed out that the Air Staff was aware that the \$18 million level would cause delays; these funds, however, would provide the necessary information for contractor selection. He did announce that release of the \$15 million had been made. Lastly, Colonel Martin directed that the term "conceptual test vehicle" would no longer be used to refer to Dyna-Soar I and, in its place, suggested the words "experimental prototype."<sup>12</sup>

The Dyna-Soar project office replied that the competitive period could be terminated by April instead of July 1959; however, additional funding could be effectively utilized.<sup>13</sup> These efforts to increase the Dyna-Soar allotment had no effect, for, on September 30, 1958, USAF headquarters now informed Detachment One that the \$10 million procurement funds for fiscal year 1959 had been canceled. All that remained for development of Dyna-Soar was



\$3 million from fiscal year 1958, with \$5 million for 1959. In his August 12 letter to General Anderson, General Wilson mentioned the possibility of increased funding for fiscal year 1959. Apparently a figure of \$14.5 million was being considered; however, Air Force headquarters also informed ARDC that this proposed increase would not be made. Headquarters further directed that expenditure rates by the contractors be adjusted in order that the \$8 million would prolong their efforts through January 1, 1959.<sup>14</sup>

From October 20 through 24, 1958, Mr. W. E. Lamar, in the Deputy for Research Vehicles and Advanced Systems, and Lieutenant Colonel R. M. Herrington, Jr., chief of the Dyna-Soar project office, briefed Air Force headquarters on the necessity of releasing funds for the Dyna-Soar program. The discussions resulted in several conclusions. The objectives of the program would remain unchanged, but further justification would have to be given to Department of Defense officials. The position of NASA in the program was reaffirmed, and it was further stipulated that ARPA would participate in system studies relating to Dyna-Soar.<sup>15</sup> These decisions, however, did not offer immediate hope for increased funding.

Early in November 1958, Colonel Herrington and Mr. Lamar briefed officials of both ARDC and USAF headquarters on the question of Dyna-Soar funding. General Anderson, after hearing the presentation, stated that he supported the program but thought that references to space operation should be deleted in the presentations to the Air Staff. Later, during a briefing to General Wilson, USAF officials decided that suborbital aspects and possibilities of a military prototype system should be emphasized. With the sanction of the Air Force Vice Chief of Staff, General C. E. LeMay, the Dyna-Soar presentation was given to Mr. R. C. Horner, the Air Force Assistant Secretary for Research and Development. The latter emphasized that if a strong weapon

system program were offered to Department of Defense officials, Dyna-Soar would probably be terminated. Rather, Secretary Horner suggested that the program be slanted towards the development of a military research system. He stated that a memorandum would be sent to the defense secretary requesting release of additional funds for Dyna-Soar.<sup>16</sup> While Colonel Herrington and Mr. Lamar achieved their funding objectives, it was also apparent that the final goal of the Dyna-Soar program--the development of an operational weapon system--was somewhat in jeopardy.

In accordance with ARDC System Development Directive 464L, the Dyna-Soar project office had completed, in November, a preliminary development plan which supplanted the abbreviated plan of October 1957. Instead of the three-step approach, the Dyna-Soar program would follow a two-phase development. Since the military test vehicle would be exploring a flight regime which was significantly more severe than that of existing Air Force systems, the first phase would involve a vehicle whose function was to evaluate aerodynamic characteristics, pilot performance, and subsystem operation. Dyna-Soar I was to be a manned glider with a highly-swept, triangular-planform wing, weighing between 7,000 and 13,000 pounds. A combination of Minuteman solid rockets could lift the vehicle, at a weight of 10,000 pounds, to a velocity of 25,000 feet per second and an altitude of 300,000 feet. By employing a liquid rocket such as the Titan system, a 13,000 pound vehicle could be propelled to a similar speed and height. The project office stipulated that a retro-rocket system to decelerate the glider and an engine to provide maneuverability for landing procedures would be necessary.

Assuming a March 1959 approval for the preliminary development plan, the Dyna-Soar office reasoned that the air-drop tests could begin in January 1962, the suborbital, manned, ground-launch tests in July 1962, and the first, piloted, global flight in

October 1963. While this first phase was under development, weapon system studies would be conducted concurrently, with the earliest operational date for a weapon system set for 1967. This Dyna-Soar weapon could perform reconnaissance, air defense, space defense, and strategic bombardment missions.<sup>17</sup> The problem of obtaining funds to continue the program, not an outline of Dyna-Soar objectives, was still, however, of immediate importance.

On December 4, 1958, the Secretary of the Air Force requested the Secretary of Defense to release \$10 million for the Dyna-Soar program. Apparently the defense department did not act immediately, for, on December 30, Air Force headquarters informed Detachment One that release of these funds could not be expected until January 1959.<sup>18</sup> The project office urgently requested that procurement authorizations be immediately issued.<sup>19</sup> Finally, on January 7, the Deputy Secretary of Defense, D. A. Quarles, issued a memorandum to the Secretary of the Air Force, which approved the release of \$10 million for the Dyna-Soar program. The deputy secretary emphasized that this was only an approval for a research and development project and did not constitute recognition of Dyna-Soar as a weapon system. The stipulated increase of \$14.5 million was not to be released until a decision was made concerning the Boeing-Martin competition.<sup>20</sup>

Air Force headquarters, on January 14, 1959, requested the Dyna-Soar office to provide a detailed program schedule. Concerning the Dyna-Soar I military test system, planning should be based on the following projected funding: \$3 million for fiscal year 1958, \$29.5 million for 1959, and \$35 million for 1960. Headquarters further directed that the competitive period for the contractors would end by April 1 with a final selection announced by July 1, 1959. While emphasis on a weapon system would be minimized, joint Air Force and ARPA weapon system studies would proceed under separate agreement with Dyna-Soar contractors. The

project office was also directed to consider two other developmental approaches. The first would assume that Dyna-Soar objectives had definitely been changed to center on a research vehicle, similar to the X-15 craft, and planning would be based on a projected funding of \$78 million for fiscal year 1961, \$80 million for 1962, \$80 million for 1963, and \$40 million for 1964. In the second approach, the Dyna-Soar program would include weapon system objectives, and a funding total of \$650 million extending from fiscal year 1961 through 1967 would be assumed. The next day, Air Force headquarters partially revised its directions by stipulating that the source selection process should be completed by May 1, 1959.<sup>21</sup>

On February 6, 1959, the Dyna-Soar project office pointed out that the May 1 date was impracticable, but the office did anticipate a presentation on source selection to the Air Council by June 1. The project office went on to emphasize that the funding forecasts were incompatible with the flight dates which had been specified to the contractors. It was apparent to the project office that only heavy expenditures during the beginning of phase two could result in the questioned flight dates. The Dyna-Soar office, consequently, requested Air Force headquarters to provide a more realistic funding schedule.<sup>22</sup>

In mid-February, the Dyna-Soar office further clarified its position. The approval of only \$5 million in development funds for fiscal year 1959 (the release of \$10 million had been for procurement), instead of a revised request of \$28 million, had a serious effect on the program by reducing the applied research and development program. Furthermore, the project office had originally requested \$187 million for fiscal year 1960, an estimate that was predicted on more extensive effort during fiscal year 1959 than was actually taking place under the reduced funding level. Air Force headquarters had only projected \$35 million for fiscal

year 1960. The result would be a prolongation of the program.<sup>23</sup> This statement of the project office had some impact on headquarters, for, on February 17, the Air Staff requested the project office provide additional information on the program based on fiscal year 1960 funding levels of either \$50 million or \$70 million.<sup>24</sup>

The depreciation of Dyna-Soar as a weapon system by the defense department, as exemplified by the Secretary Quarles' memorandum of January 7, did not alter the necessity, in the opinion of the Air Force, for a boost-glide weapon. On February 17, 1959, Air Force headquarters revised its General Operation Requirement 92, previously issued on May 12, 1955. Instead of referring to a high-altitude reconnaissance system, the Air Force now concentrated on a bombardment system. USAF headquarters stated that this system, capable of target destruction, was expected to operate at the fastest attainable hypersonic speed, within and above the stratosphere, and could complete at least one circumnavigation of the Earth. This projected system would be capable of operation from 1966 to 1970.<sup>25</sup>

On April 13, 1959, Dr. H. F. York, Director of Defense for Research and Engineering, firmly established the objectives for Dyna-Soar I. The primary goal was the non-orbital exploration of hypersonic flight up to a velocity of 22,000 feet per second. Launched by a booster already in production or planned for the national ballistic missile and space programs, the vehicle would be manned, maneuverable, and capable of controlled landings. Secondary objectives were the testing of military subsystems and the attainment of orbital velocities. The Department of Defense instructed that the accomplishment of these last objectives should only be implemented if there were no adverse effects on the primary objective. The additional \$14.5 million was now authorized for fiscal year 1959, giving a total of \$29.5 million for that year.

The Department of Defense inquired whether this figure plus a proposed \$35 million for fiscal year 1960 would be sufficient to carry out the program. If the Air Force did not consider this feasible, then an alternate program should be submitted for review.<sup>26</sup>

Command headquarters was not in accord with these directions. In an effort to fulfill the conditions established by General Operational Requirement 92, the research and development command issued, on May 7, 1959, ARDC System Requirement 201. The Dyna-Soar I vehicle was to be a military test system developed under the direction of the Air Force with technical assistance from the National Aeronautics and Space Administration. The purpose of this system would be to determine the military potential of a boost-glide weapon system and provide research data on flight characteristics up to and including global flight. Concurrently, studies would be made concerning a weapon system based on this type of hypersonic vehicle. Headquarters then directed its Detachment One to prepare a development plan for Dyna-Soar by November 1, 1959.<sup>27\*</sup>

Major General Haugen, in reply to the directions of Dr. York, "strongly recommended" that the attainment of orbital velocities and the testing of military subsystems should be a primary, not a secondary objective. He further stated that Dyna-Soar was the only manned vehicle program which could determine the military potential in the near-space regime. It was "extremely important," the systems management director stated, that the accomplishment of the Dyna-Soar mission not be compromised by restrictions which limited safety, reliability, and growth potential in deference to short-term monetary savings.<sup>28</sup>

---

\*By January 1959, the preliminary development plan of November 1958 had been forwarded to ARDC and USAF headquarters, however, apparently neither headquarters gave it official sanction.

General Haugen's organization then drew up a position paper substantiating these recommendations. The directorate firmly believed that both the primary and secondary objectives had to be achieved. Concentration on the first set of objectives would prevent investigation of reentry from orbit and the adequate testing of military subsystems. The directorate then recommended a program involving the fabrication of eight unmanned vehicles, eight manned vehicles, and 27 boosters, all to be employed in a total of 25 launchings. This would cost a total of \$665 million. While modification of this program to conform with only the primary objectives would reduce the cost by \$110 million, it would seriously lessen the possibility of evolving a weapon system from Dyna-Soar I.<sup>29</sup>

Excluding \$18 million expended during contract competition, the Deputy Chief of Staff for Development in Air Force headquarters established, on May 28, \$665 million as the maximum total of the Dyna-Soar program. For planning purposes \$77 million was set for fiscal year 1960.<sup>30</sup> On June 11, 1959, the Air Force Council considered this last figure to be excessive, and the deputy chief of staff had to recant: \$35 million was to be used in place of the \$77 million.<sup>31</sup>

During a briefing on June 23, 1959, officials of the project office and Dr. J. V. Charyk, Assistant Secretary of the Air Force for Research and Development, further discussed the questions of Dyna-Soar funding and objectives. Apparently, Dr. Charyk, at this point, was not in full agreement with Dr. York's position. The assistant secretary considered that the overall purpose of the program was to exploit the potentialities of boost-glide technology, and, consequently, he implied that orbital velocities should be attained early in the program. For fiscal year 1960, he favored \$77 million instead of \$35 million but raised the question of how much a total funding level of \$300 million to \$500 million

would compromise the program.\* Dr. Charyk then reported to the project officials that Dr. York appeared quite concerned over the effort necessary for modification of a proposed Dyna-Soar booster.<sup>32</sup>

The Air Force source selection board had already appraised the Boeing and Martin proposals. Although both contractors offered similar delta-wing designs, they differed in their selection of boosters. While Boeing only considered an orbital Atlas-Centaur combination, Martin officials offered a suborbital Titan A (later renamed the Titan I) and an orbital Titan C. The board deemed the Boeing glider superior but also recommended use of Martin's orbital booster. The Secretary of the Air Force, J. H. Douglas, did not agree. Development of a new booster, capable of orbital velocities, was clearly not in accord with Dr. York's direction. The secretary recommended further study of the configuration and size of the vehicle to determine whether the glider could be modified to permit compatibility with a basic, suborbital, Titan system. Furthermore, Secretary Douglas was concerned about the total cost of the program. He did not think that funding should be increased by attempting to configure a vehicle which conformed to an anticipated weapon system. Consequently, the Secretary of the Air Force directed a reassessment of the Dyna-Soar program, with the ultimate objective of reducing the overall expense. Accordingly, USAF headquarters directed Detachment One to examine the possibilities for a lighter vehicle and to analyze a development program based on a total cost of not more than \$500 million.<sup>33</sup>

---

\*The documentary source, as cited in reference 32, for Dr. Charyk's comments referred to the \$77 million and \$35 million as projected figures for fiscal year 1959. Placed in context of the funding discussions concerning the Dyna-Soar program, these estimates obviously applied to fiscal year 1960 and not 1959.



Designation of the booster, management of booster development and procurement, and most important, the purpose of the program, were problems that became intertwined in the series of discussions following Secretary Douglas' instructions. After a July 14 meeting with Dr. Charyk, General Boushey, Colonel W. L. Moore, Jr., and Lieutenant Colonel Ferer, General Haugen directed systems management to prepare a presentation designed to answer the questions raised by Secretary Douglas and also to outline the participation of the Ballistic Missiles Division (BMD) in the Dyna-Soar program.\* After reviewing this briefing on July 22, 1959, Lieutenant General B. A. Schriever, now ARDC commander, instructed General Haugen's directorate to prepare a detailed management plan for booster development.<sup>34\*\*</sup> Dr. York, however, on July 27, placed a new complication in this planning effort by requesting the Air Force secretary and the director of ARPA to investigate the possibility of a common development of a Dyna-Soar booster and a second stage for the Saturn booster of NASA. The Director of Defense for Research and Engineering stated that no commitments for the propulsion system would be made until this proposal had been considered. Dr. York apparently had in mind reviving consideration of the Titan C for System 464L and modifying this booster for use in the Saturn program.<sup>35</sup>

On July 28 and 29, General Haugen and Brigadier General O. J. Ritland, BMD commander, completed a tentative agreement concerning the management of Dyna-Soar booster development. During a series of meetings on August 11 and 13, however, General Schriever and General Anderson, AMC commander, could not

---

\*Colonel Moore succeeded Colonel R. M. Herrington, Jr., as chief of the Dyna-Soar Weapon System Project Office early in July 1959.

\*\*On March 10, 1959, Lieutenant General S. E. Anderson, previously ARDC commander, became commander of the Air Materiel Command. Lieutenant General B. A. Schriever, on April 25, 1959, assumed command of ARDC.

agree on a method of booster procurement. With the exception of the parts pertaining to BMD participation in the Dyna-Soar program, Mr. Lamar then gave the Dyna-Soar presentation to Dr. Charyk, with Generals Wilson, Ferguson, and Haugen attending. After preliminary data was given on Titan C and the Saturn second stage, Dr. Charyk was asked to recommend to the defense department that a contractor source selection be made for Dyna-Soar. He declined: subcontractor selection had not been adequately competitive and the proposed Dyna-Soar funding was too high.<sup>36</sup>

By the middle of August, the Ballistic Missiles Division had completed its evaluation of possible Dyna-Soar boosters. Largely because of serious stability and control problems, an Atlas-Centaur combination was rejected in favor of the Titan C. Concerning Dr. York's proposal, west coast officials believed that it was impractical to employ a precisely identical booster stage for both the Dyna-Soar and Saturn projects. Since Titan C was essentially a cluster of four LR87-AJ-3 engines, ballistic division engineers did recommend employing two of these propulsive units as a Saturn second stage.<sup>37</sup> Discussions between Dr. Charyk, Dr. York, and ballistic division officials concerning selection of the Dyna-Soar booster followed. Finally, while a booster was not designated, Dr. Charyk, Generals Wilson, Ferguson, and Boushey decided, on September 25, that Titan C would not be employed in the program.<sup>38</sup>

On September 23, Lieutenant General W. F. McKee, AMC vice commander, took up the question of booster procurement and proposed to General Schriever a management plan, based on discussions between ARDC and AMC personnel, for the Dyna-Soar program. Because of the wide participation of government agencies and industry, control of Dyna-Soar had to be centralized in a specific organization. While the system was to be procured under two contracts, one for the glider and one for the propulsion unit, the contractor responsible for the manufacture of the vehicle would be

given responsibility for integration of the entire system and would act as weapon system contractor. Overall management would be vested in a joint ARDC and AMC project office located at Wright-Patterson Air Force Base. Concerning the procurement authority of the Aeronautical Systems Center (ASC) and the Ballistic Missiles Center (BMC), both of the materiel command, General McKee suggested that the aeronautical center negotiate the two contracts, utilizing the experience available at the ballistic center. The Aeronautical Systems Center, however, would delegate authority to the ballistic center to contractually cover engineering changes. This delegation would be limited to actions not affecting overall cost, compatibility between booster and vehicle, and system performance. General McKee closed by recommending that ARDC and AMC forward a message to Air Force headquarters outlining this proposal.<sup>39</sup>

General Schriever, on October 2, informed AMC officials that he agreed with General McKee's proposed message to USAF headquarters. He did wish to point out, however, that the plan did not adequately reflect the increased role that ARDC agencies at Wright Field were intending to play. General Schriever further stated that ARDC was going to establish a single agency for all booster research and development which would incorporate the use of BMD and BMC.<sup>40</sup> General Anderson replied that he did not understand the ARDC commander's statement concerning increased management responsibility of Wright agencies. He stated that the AMC plan stressed this aspect. General Anderson further emphasized that the materiel command recognized BMD's technical responsibility for the Dyna-Soar booster and had agreed to delegate necessary procurement authority. The AMC commander did not think it was necessary, however, to delegate authority to negotiate contracts. This authority, along with overall technical management, should rest in the ARDC and ASC weapon system project offices.<sup>41</sup>

On October 29, General Boushey re-examined the Dyna-Soar requirements established by the April 13 memorandum of Dr. York. Orbital flight and testing of military subsystems could only be permitted, Dr. York insisted, if these efforts did not adversely affect the central objective of non-orbital, hypersonic flight. General Boushey reiterated the opinion of USAF headquarters: both sets of objectives should be definitely achieved. Assuming a total funding of \$665 million, ARDC was directed to formulate a two-phase development approach for a 9,000 to 10,000 pound glider.<sup>42</sup>

By November 1, 1959, the Dyna-Soar office completed an abbreviated development plan in fulfillment of ARDC System Requirement 201. As suggested by the Office of the Secretary of Defense, the project office once again structured the program in a three-step approach. In Step I, a manned glider, ranging in weight from 6,570 to 9,410 pounds would be propelled to suborbital velocities by a modified Titan booster. Step II encompassed manned orbital flight of the basic glider and interim military operations. A weapon system, founded on technology from the previous steps, comprised Step III. The project office anticipated 19 air-drop tests to begin in April 1962; the first of eight unmanned, suborbital flights to occur in July 1963; and the first of eight piloted, suborbital launches to take place in May 1964. The first, manned, global flight of Step II was scheduled for August 1965. To accomplish this program, the project office estimated the development cost to total \$623.6 million from fiscal year 1960 through 1966.<sup>43</sup> On November 2, the Weapons Board of Air Force headquarters approved the revised Dyna-Soar plan. The Air Council, in addition to sanctioning the three-step program, also approved of an ARDC and AMC arrangement concerning booster procurement.<sup>44</sup>

Generals Schriever and Anderson, on November 4, forwarded a joint ARDC and AMC letter to USAF headquarters. After detailing the essentials of the program, the two commanders outlined their

agreement on booster procurement: the project office would utilize the "experience" of the ballistic division in obtaining a booster for Dyna-Soar. They further stated that the proposed program would make full use of existing national booster programs, essentially satisfying Dr. York's requirement, and would also attain Air Force objectives by achieving orbital velocities. General Schriever and General Anderson closed by urging the source selection process to be completed.<sup>45</sup>

Following this advice, the Secretary of the Air Force, on November 9, 1959, announced the Dyna-Soar contracting sources. The Boeing Airplane Company had won the competition and was awarded the systems contract. The Martin Company, however, was named associate contractor with the responsibility for booster development.<sup>46</sup> On November 17, Air Force headquarters directed the research and development command to implement Step I and to begin planning for Step II of the Dyna-Soar program.<sup>47</sup> Three days later, Dr. Charyk gave the Air Force authority to negotiate Step I contracts for fiscal year 1960. There was, however, an obstruction. The assistant secretary instructed the Deputy Chief of Staff for Development that, prior to obligating any funds for the Dyna-Soar program, now designated System 620A, Dr. Charyk's office would have to be given financial plans and adequate work statements. No commitments could be made before the Air Force had a concise understanding of the direction of the project.<sup>48</sup>

In an effort to obtain approval to obligate funds for fiscal years 1959 and 1960, General Boushey and some of his staff met with Dr. Charyk on November 24, and Dr. Charyk made it clear that he did not wish to release any funds for Dyna-Soar at that time. Instead, he was going to institute Phase Alpha, the purpose of which would be to examine the step-approach, the proposed booster, the vehicle size, and the flight test objectives. Dr. Charyk stated that no funds would be obligated until the Alpha exercise was completed.

Once Dyna-Soar was implemented, the assistant secretary wanted to review the program step-by-step and release funds as the program proceeded.<sup>49</sup> To cover the work carried on under Phase Alpha, the Air Force released a total of \$1 million. Pending further approval by Dr. Charyk, obligations could not exceed this amount.<sup>50</sup>

## NOTES

1. SDD 464L, Hqs. ARDC, 12 Dec. 1957.
2. Ltr., Col. H. M. Harlow, Dir., F-106 WSP0, ASC, AMC to Source Selection Bd., 25 Jan. 1958, subj.: Report of Working Group for System 464L; mangt. rpt., W. E. Lamar, Asst. Ch., Bomb. Ac. Div., Det. 1, Hqs. ARDC, 4 Feb. 1958, subj.: Hypersonic Strategic Weapon System.
3. Rpt., Source Selection Bd., ident. no. 58RDZ-9197, subj.: Summary of Contractor Proposals.
4. DSM WAR, 10 Apr. 1958; TWX, AFDRD-AN-31317, Hqs. USAF to Cmdr., Det. 1, Hqs. ARDC, 16 June 1958.
5. Ltr., Maj. Gen. R. P. Swofford, Jr., Acting DCS/Dev., Hqs. USAF to Cmdr., ARDC, 25 June 1958, subj.: Selection of Contractor for WS 464L (Dyna-Soar) Development.
6. Ltr., Maj. Gen. J. W. Sessums, Jr., Vice Cmdr., ARDC to Lt. Gen. R. C. Wilson, DCS/Dev., Hqs. USAF, 11 July 1958.
7. Ltr., Lt. Gen. D. L. Putt, DCS/Dev., Hqs. USAF to Dr. H. L. Dryden, Dir., NACA, 31 Jan. 1958; TWX, RDZPR-2-9-E, Hqs. ARDC to Cmdr., Det. 1, Hqs. ARDC, 13 Feb. 1958; memo., Gen. T. D. White, CS/AF and Dr. H. L. Dryden, Dir., NACA, 20 May 1958, subj.: Principles for Participation of NACA in the Development and Testing of the "Air Force System 464L Hypersonic Boost Glide Vehicle (Dyna-Soar I);" memo., Gen. White and T. K. Glennan, Administrator, NASA, 14 Nov. 1958, subj.: Principles for Participation of NASA in the Development and Testing of the "Air Force System 464L Hypersonic Boost Glide Vehicle (Dyna-Soar I)."
8. Ltr., Lt. Gen. R. C. Wilson, DCS/Dev., Hqs. USAF to Maj. Gen. J. W. Sessums, Jr., Vice Cmdr., ARDC, 23 July 1958.
9. Ltr., Lt. Gen. S. E. Anderson, Cmdr., ARDC to Lt. Gen. R. C. Wilson, DCS/Dev., Hqs. USAF, 24 July 1958.
10. Ltr., Lt. Gen. R. C. Wilson, Hqs. USAF to Lt. Gen. S. E. Anderson, Cmdr., ARDC, 12 Aug. 1958.
11. Ltr., Maj. Gen. V. R. Haugen, Asst. Dep. Cmdr/Weap. Sys., Det. 1, Hqs. ARDC to DCS/Dev., Hqs. USAF, 6 Aug. 1958.
12. Ltr., Col. J. L. Martin, Jr., Acting Dir., Adv. Tech., Hqs. USAF to Cmdr., Det. 1, Hqs. ARDC, 4 Sept. 1958, subj.: Action on Dyna-Soar.

13. TWX, RDZSXB-3117, Cmdr., Det. 1, Hqs. ARDC to Hqs. USAF, 16 Sept. 1958.
14. TWX, AFDAT-58885, Hqs. USAF to Cmdr., Det. 1, Hqs. ARDC, 30 Sept. 1958.
15. Chronology, Dyna-Soar WSP0, ident. no. 60WWZR-14775, hereafter cited as Dyna-Soar Chronology; DSM WAR, 31 Oct. 1958.
16. DSM WAR, 14 Nov. 1958; Dyna-Soar Chronology.
17. Preliminary Development Plan, System 464L, Det. 1, Hqs. ARDC, Nov. 1958, pp. 2, 8, 11, 32.
18. Dyna-Soar Chronology; TWX, AFDAT-54520, Hqs. USAF to Cmdr., Det. 1, Hqs. ARDC, 30 Dec. 1958.
19. TWX, RDZSXB-12-31619-E, Cmdr., Det. 1, Hqs. ARDC to Hqs. USAF, 31 Dec. 1958.
20. Memo., Dep. Secy. of Def. to SAF, 7 Jan. 1959.
21. TWX, AFDAT-55061, Hqs. USAF to Cmdr., Det. 1, Hqs. ARDC, 14 Jan. 1959; TWX, AFDAT-48049, Hqs. USAF to Cmdr., Det. 1, Hqs. ARDC, 16 Jan. 1959.
22. TWX, RDZSXB-30164-E, Cmdr., Det. 1, Hqs. ARDC to Hqs. USAF, 6 Feb. 1959.
23. TWX, Cmdr., Det. 1, Hqs. ARDC to Hqs. USAF, 13 Feb. 1959.
24. TWX, AFDAT-56643, Hqs. USAF to Cmdr., Det. 1, Hqs. ARDC, 17 Feb. 1959.
25. GOR 92, revised, Hqs. USAF, 17 Feb. 1959.
26. TWX, AFDAT-59299, Hqs. USAF to Cmdr., ARDC, 24 Apr. 1959.
27. SR 201, Hqs. ARDC, 7 May 1959.
28. Ltr., Maj. Gen. V. R. Haugen, Asst. Dep. Cmdr/Weap. Sys., Det. 1, Hqs. ARDC to Hqs. USAF, 15 May 1959, subj.: Dyna-Soar I Program Guidance.
29. Rpt., DSM, Det. 1, Hqs. ARDC, subj.: Dyna-Soar, Substantiation of RDZ Program.
30. TWX, AFDAT-51437, Hqs. USAF to Cmdr., Det. 1, Hqs. ARDC, 28 May 1959.
31. DSM WAR, 12 June 1959; Dyna-Soar Chronology.



32. Presn., W. E. Lamar, Dep. Dir/Dev., Dyna-Soar SPO, ASD to Hqs. AFSC, 20 Feb. 1963, subj.: History of Dyna-Soar (X-20) to Present; memo., Lt. Col. B. H. Ferer, Asst. Boost-Glide Sys. DCS/Dev., Hqs. USAF, 24 June 1959, subj.: Dyna-Soar Briefing to Dr. Charyk, Tuesday, 23 June 1959.
33. TWX, AFDAT-53166, Hqs. USAF to Cmdr., Det. 1, Hqs. ARDC, 10 July 1959.
34. TWX, RDG-23-7-5-E, Hqs. ARDC to Hqs. BMD, 23 July 1959; rpt., DSM, Det. 1, Hqs. ARDC, ident. no. 59RDZ-23128, subj.: Dyna-Soar Meeting, July-August 1959.
35. Memo., Dr. H. F. York, DDR&E, DOD to SAF and Dir., ARPA, DOD, 27 July 1959, subj.: Saturn, Dyna-Soar Propulsion.
36. Dyna-Soar Chronology.
37. Ltr., Brig. Gen. C. H. Terhune, Jr., Vice Cmdr., BMD to Det. 1, Hqs. ARDC, 13 Aug. 1959, subj.: Dyna-Soar Booster Evaluation.
38. Ltr., Brig. Gen. H. A. Boushey, Dir., Adv. Tech., DCS/Dev., Hqs. USAF to Hqs. ARDC, 29 Oct. 1959, subj.: Required Action on Dyna-Soar.
39. Ltr., Lt. Gen. W. F. McKee, Vice Cmdr., AMC to Cmdr., ARDC, 23 Sept. 1959, subj.: The Dyna-Soar Program.
40. TWX, Lt. Gen. B. A. Schriever, Cmdr., ARDC to Lt. Gen. S. E. Anderson, Cmdr., AMC, 12 Oct. 1959.
41. TWX, Lt. Gen. S. E. Anderson, Cmdr., AMC to Lt. Gen. B. A. Schriever, Cmdr., ARDC, 14 Oct. 1959.
42. Ltr., Brig. Gen. Boushey to Hqs. ARDC, 29 Oct. 1959, subj.: Required Action on Dyna-Soar.
43. Abbreviated Development Plan, System 464L, Dyna-Soar WSPO, Det. 1, Hqs. ARDC, 1 Nov. 1959.
44. DSM WAR, 6 Nov. 1959.
45. Ltr., Lt. Gen. B. A. Schriever, Cmdr., ARDC and Lt. Gen. S. E. Anderson, Cmdr., AMC to Hqs. USAF, 4 Nov. 1959, subj.: Dyna-Soar Selection.
46. DSM WAR, 13 Nov. 1959; TWX, RDZSXB-31253-E, Det. 1, Hqs. ARDC to Hqs. BMD, 10 Nov. 1959; TWX, RDZSXB-31261-E, DSM, Hqs. ARDC to Hqs. SAC, 13 Nov. 1959.
47. TWX, AFDAT-90938, Hqs. USAF to Cmdr., ARDC, 17 Nov. 1959.

48. Memo., Dr. J. V. Charyk, ASAF/Res. & Dev. to DCS/Dev., Hqs. USAF, 20 Nov. 1959, subj.: D&F 50-11-284 Dyna-Soar program.

49. Memo., Lt. Col. B. H. Ferer, Asst/Boost-Glide Sys., DCS/Dev., Hqs. USAF, 24 Nov. 1959, subj.: Assistant Secretary Air Force R&D Restrictions on Dyna-Soar Determinations and Findings.

50. TWX, AFDAT-95166, Hqs. USAF to Cmdr., ARDC, 7 Dec. 1959.

## CHAPTER III

### PHASE ALPHA AND ITS RESULTS

Before the Dyna-Soar Weapon System Project Office could undertake the suborbital Step I of the program, the Air Force had to institute Phase Alpha and appraise the Dyna-Soar approach to eventual manned orbital flight. Early in December 1959, the Aero and Space Vehicles Panel of the Scientific Advisory Board offered some recommendations concerning the objectives of this study. The panel pointed to the inadequacy of technical knowledge in the areas of aerodynamics and structures and, consequently, considered that development test programs to alleviate these deficiencies should be formulated during the study. Concerning the entire program, the scientific advisory group strongly supported the Dyna-Soar approach. While the program could be severely limited by a restricted budget and the absence of a high military priority, the Aero and Space Vehicles Panel insisted that Dyna-Soar was important because, if properly directed, it could yield significant information in the broad research areas of science and engineering.<sup>1</sup>

Dr. J. V. Charyk, Assistant Secretary of the Air Force for Research and Development, concurred with the position of the panel. In Alpha, emphasis would be placed on the identification and solutions of technical problems, and the objective of Step I would be the development of a test vehicle rather than a weapon system. Dr. Charyk then authorized the release of an additional \$2.5 million for this study.<sup>2</sup>

On December 11, 1959, the Air Force and the Boeing Airplane Company had already signed a contract for the Alpha study, but the Air Force was undecided as to which contractors or Air Force agencies would provide Boeing with booster analyses. By the end of

January 1960, the Dyna-Soar office recommended that the Ballistic Missile Division and the Space Technology Laboratories provide the booster studies. Since Alpha had to be completed in March 1960, the project office did not consider that there was sufficient time to complete a contract with Martin for the Alpha study.<sup>3</sup> The Aeronautical Systems Center objected and maintained that the existing contracts with Boeing could not be extended to allow participation in booster studies.<sup>4</sup> Command headquarters disagreed and resolved the issue on February 3: the Ballistic Missiles Center would arrange contracts with the space laboratories and the Martin Company and the Aeronautical Systems Center would extend the Boeing contract.<sup>5</sup>

Booster information for Alpha was not the only problem; ARDC headquarters still had to settle the question of booster procurement for the entire Dyna-Soar program. Lieutenant General B. A. Schriever, Commander of ARDC, and Lieutenant General S. E. Anderson, Commander of AMC, had apparently delineated the authority of their respective commands in their November 4, 1959 letter, but a formal agreement had not been reached. Early in December 1959, General Schriever had completed an agreement within his command which assigned technical responsibility for booster development to the Ballistic Missiles Division. General Schriever hoped that General Anderson also intended to delegate commensurate contractual authority to the Ballistic Missiles Center.<sup>6</sup> General Anderson was essentially in agreement with General Schriever's position, but he objected to an agreement made between the ARDC project office and the ballistic division without participation of AMC elements. Consequently, the air materiel commander urged that the two commands complete a joint agreement concerning the development of the Dyna-Soar booster.<sup>7</sup>

On February 8, 1960, Generals Schriever and Anderson reached such an understanding which detailed the position of the west coast complex in the Dyna-Soar program. While management and financial authority for the entire program rested in the weapon system

project office, the ballistic division and center, with the approval of the system office, would define the statements of work and complete contractual arrangements for the booster development. All changes in the booster program which significantly altered performance, configuration, cost, or schedules, however, would necessitate concurrence of the project office.<sup>8</sup>

In the middle of January 1960, Brigadier General H. A. Boushey, Assistant for Advanced Technology in Air Force headquarters, gave more specific instructions concerning the direction of the Phase Alpha study. The objective of this review was to examine selected configurations for controlled, manned reentry to determine the technical risks involved in each and to define a development test program for Step I.<sup>9</sup> In order to evaluate the efforts of Boeing, Martin, the ballistic division, and the space laboratories in this study, Colonel W. R. Grohs, Vice Commander of the Wright Aeronautical Development Division (WADD), then directed the formation of an ad hoc committee.<sup>10</sup> \*

This group was established early in February with representation not only from the Wright division but also from the Air Force Flight Test Center, the Air Force Missile Test Center, the Air Materiel Command, and the National Aeronautics and Space Administration. The central objective of this committee was to determine the kind of research vehicle the Air Force required to solve the problems involving manned reentry from orbital flight. Consequently, the ad hoc committee contracted with several companies, which were placed under the direction of Boeing, to investigate the potentialities of several categories of configurations. Variable geometric shapes such as the drag brake of the AVCO Manufacturing Corporation, a folding-wing glider of Lockheed Aircraft, and an inflatable device of Goodyear Aircraft were all examined. The committee also analyzed ballistic shapes

---

\*With the formation of the Wright Air Development Division, on December 15, 1959, the management of weapon system development was transferred from ARDC headquarters to the Wright complex.

such as a modified Mercury Capsule of McDonnell and lifting body configurations offered by the ad hoc committee itself and General Electric. Finally, gliders with varying lift-to-drag ratios were also proposed by the committee, Bell Aircraft, Boeing, and Chance-Vought Aircraft.

After examining these various configurations, the ad hoc group concluded that the development and fabrication of a ballistic shape or a lifting body configuration with a lift-to-drag ratio up to 0.5 would only duplicate the findings of the National Aeronautics and Space Administration in its Mercury program. Conversely, a glider with a high lift-to-drag ratio of 3.0 would not only provide a maximum amount of information on reentry but would also demonstrate the greatest maneuverability in the atmosphere and allow the widest selection of landing sites. Such a glider, however, presented the most difficult design problems. Consequently, the ad hoc committee decided that a medium lift-to-drag glider, in the range of 1.5 to 2.5, offered the most feasible approach for advancing knowledge of reentry problems.<sup>11</sup>

At the end of March 1960, the Aero and Space Vehicles panel again reviewed the Dyna-Soar program with emphasis on the results of the Alpha study. If the overriding requirement were to orbit the greatest weight in the shortest development time, the panel reasoned that the modified ballistic approach was preferable. However, the members noted that gliders would advance technical knowledge of structures and would provide the greatest operational flexibility. The vehicles panel further emphasized the importance of attaining early orbital flight and, consequently, suggested a reexamination of the need for a sub-orbital Step I and more precise planning for the orbital Step II.<sup>12</sup>

The Dyna-Soar glider, as conceived by the Alpha group and the project office, was to be a low-wing, delta-shape vehicle weighing about 10,000 pounds. To undergo the heating conditions during reentry, the framework was to be composed of Rene' 41 braces which

would withstand a temperature of 1800 degrees Fahrenheit. The upper surface of the glider was to be fabricated of Rene' 41 panels, where the temperature was expected to range from 500 to 1900 degrees. The lower surface was to be a heat shield, designed for a maximum temperature of 2700 degrees, and was to consist of molybdenum sheets attached to insulated Rene' 41 panels. The leading edge of the wings would have to withstand similar heat conditions and was to be composed of coated molybdenum segments. The severest temperature, ranging from 3600 to 4300 degrees, would be endured by the nose cap, which was to be constructed of graphite with zirconia rods.<sup>13</sup>

In conjunction with the ad hoc group, the Dyna-Soar project office completed, by April 1, 1960, a new development plan which further elaborated the three-step program presented in the November 1959 approach. Step I was directed towards the achievement of four objectives: exploration of the maximum heating regions of the flight regime, investigation of maneuverability during reentry, demonstration of conventional landing, and evaluation of the ability of man to function usefully in hypersonic flight. While Step I was limited to suborbital flight, the purpose of Step IIA was to gather data on orbital velocities and to test military subsystems, such as high resolution radar, photographic and infrared sensors, advanced bombing and navigation systems, advanced flight data systems, air-to-surface missiles, rendezvous equipment, and the requisite guidance and control systems. While Step IIB would provide an interim military system capable of reconnaissance and satellite inspection missions, the objective of Step III was a fully operational weapon system.

Whereas the last two steps were only outlined, the main consideration of the project office was the suborbital Step I. In order to demonstrate the flying characteristics of the glider up to speeds of Mach 2, the Dyna-Soar office scheduled a program of 20

air-drop tests from a B-52 carrier to begin in July 1963.\* Beginning in November 1963, five unmanned flights were to be conducted in Mayaguana in the Bahama Islands and Fortaleza, Brazil, with velocities ranging from 9,000 to 19,000 feet per second. Eleven piloted flights, scheduled to start in November 1964, would then follow, progressively increasing the velocity to the maximum 19,000 feet per second and employing landing sites in Mayaguana, Santa Lucia in the Leeward Islands, and, finally, near Fortaleza.

To accomplish this Step I program, the Dyna-Soar office estimated that \$74.9 million would be required for fiscal year 1961, \$150.9 million for 1962, \$124.7 million for 1963, \$73.6 million for 1964, \$46.8 million for 1965, and \$9.9 million for 1966. Including \$12.8 million for 1960, these figures totalled \$493.6 million for the suborbital program.<sup>14</sup>

During the first week in April 1960, officials of the Dyna-Soar project office presented the new development plan and the results of Phase Alpha to Generals Schriever, Anderson, and Boushey, and the Strategic Air Panel and the Weapons Board of Air Force headquarters. On April 8, Dyna-Soar representatives explained the program to the Assistant Secretary of the Air Force for Research and Development, now Professor C. D. Perkins, and received his approval to begin work on the suborbital Step I.<sup>15</sup> On April 19, the Assistant Secretary of the Air Force for Materiel, P. B. Taylor, authorized negotiations of fiscal year 1961 contracts for this phase of the program.\*\* The Department of Defense, on April 22, endorsed the new program and permitted the release of

---

\*For the air-drop program, the Dyna-Soar office was considering employment of either the XLR-11 or the AR-1 liquid rocket engines to propel the glider to specified speeds. Late in 1960, however, the project office decided to use a solid acceleration rocket not only for abort during launch but also for the air-drop tests.

\*\*On April 24, 1961, Dr. Charyk, then Under Secretary of the Air Force, permitted contractual arrangements for the entire Step I program rather than for only particular fiscal years.



\$16.2 million of fiscal year 1960 funds.<sup>16</sup> Consequently, on April 27, the Air Force completed a letter contract with the Boeing Airplane Company as system contractor. Source selection procedures had previously been initiated for the award of two associate contracts. On December 6, 1960, the Air Force granted authority to the Minneapolis-Honeywell Regulator Company for the primary guidance subsystem, and, on December 16, the Air Force gave responsibility to the Radio Corporation of America for the communication and data link subsystem.\*

Air Force headquarters, on July 21, 1960, further recognized the three-step program by issuing System Development Requirement 19. With the segmented approach, the Air Force could develop a manned glider capable of demonstrating orbital flight, maneuverability during hypersonic glide, and controlled landings. Furthermore, Dyna-Soar could lead to a military system able to fulfill missions of space maneuver and rendezvous, satellite inspection, and reconnaissance. Headquarters looked forward to the first manned suborbital launch which was to occur in 1964.<sup>17</sup>

While the Step I program was approved and funded, the Dyna-Soar project office firmly thought that studies for the advanced phases of the program should also be initiated. In early August 1960, the project office recommended to ARDC headquarters that \$2.32 million should be made available through fiscal year 1962 for this purpose. If these funds were released immediately, the project office anticipated completion of preliminary program plans for Steps IIA, IIB, and III by December 1961, January 1962, and June 1962, respectively.<sup>18</sup> Later in the month the Dyna-Soar office again

---

\*The Air Force granted three other associate contracts for the Dyna-Soar program. On June 8, 1960, the Martin Company received responsibility for the booster airframe, while, on June 27, the Air Force authorized the Aero-Jet General Corporation to develop the booster engines. Previously, on June 9, the Air Force made arrangements with the Aerospace Corporation to provide technical services for the Step I program.

reminded command headquarters of the urgency in releasing these funds.<sup>19</sup>

The apparent source of delay was that the authority to negotiate contracts, issued by Assistant Secretary Taylor on April 19, 1960, referred specifically to Step I of the program. Colonel E. A. Kiessling, Director of Aeronautical Systems in ARDC headquarters, met with Professor Perkins on September 22 and 23, and the assistant secretary agreed that this authority did not prohibit Step II and III studies. The restraint only applied to the expenditure of fiscal year 1961 funds for the purchase of equipment for the advanced phases.<sup>20</sup> \* This decision was confirmed on October 12 when Air Force headquarters approved Steps II and III studies by issuing Development Directive 411.<sup>22</sup> \*\* ARDC headquarters then issued, on December 6, a system study directive for Step III and allotted \$250,000 for this work.<sup>24</sup> By the middle of 1961, however, it was questionable whether the Air Force would continue the three-step approach. The Air Staff consequently postponed the Step III investigation, and early in 1962 command headquarters canceled the study.<sup>25</sup>

In the April 1960 development plan the Dyna-Soar office had proposed the employment of Titan I as the Step I booster. The

---

\*Colonel T. T. Omohundro, Deputy Director for Aeronautical Systems, ARDC headquarters, informed the Dyna-Soar office, on October 4, 1960, that Air Force headquarters would probably have to issue a new authority to negotiate contracts for Step II and III studies before funds could be released. Apparently, Colonel Kiessling had not told his deputy of Professor Perkins' previous decision.<sup>21</sup>

\*\*On February 14, 1961, the Air Force and Boeing completed a contract for Step IIA and IIB studies with an effective date of November 9, 1960. Boeing was allotted \$1.33 million and given until June 30, 1962 to complete the studies. With the assumption that a new orbital booster would provide Step II propulsion, Boeing concluded that it was feasible for the Dyna-Soar glider to perform military missions such as reconnaissance, satellite interception and inspection, space logistics, and bombardment. The last mission, however, the contractor considered could be performed with less expense by intercontinental ballistic missiles.<sup>23</sup>

first stage of this system was powered by the LR87-AJ-3 engine, capable of developing 300,000 pounds of thrust, while the second stage, an LR91-AJ-3 engine, could produce 80,000 pounds of thrust. This booster would be able to propel the Dyna-Soar glider to a velocity of 19,000 feet per second on a suborbital flight from Cape Canaveral to Fortaleza, Brazil. Professor Perkins, however, considered this booster marginal for Step I flights and, on November 28, 1960, requested the Air Force to examine the feasibility of employing Titan II for the suborbital step and a combination Titan II first stage and a Centaur-derivative upper stage for the orbital phase.<sup>26</sup> The Titan II was a two-stage liquid rocket and, unlike the Titan I, employed hypergolic, storable propellants. The first stage consisted of an XLR87-AJ-5 engine, capable of producing 430,000 pounds of thrust, while the second stage was an XLR91-AJ-5 unit, capable of delivering 100,000 pounds of thrust.

Late in December 1960 Mr. R. C. Johnston of the Dyna-Soar office and Major G. S. Halvorsen of the Ballistic Missiles Division presented the advantages of Titan II to ARDC headquarters, and the proposal to employ the advanced Titan received the endorsement of General Schriever. A presentation to Air Force headquarters followed. Assistant Secretary Perkins appeared satisfied with the recommendation but stated that Department of Defense approval would probably not be given unless the booster change was considered in conjunction with an anticipated funding level of \$70 million for fiscal year 1962, instead of the requested \$150 million.<sup>27</sup>

A few days later the project office protested the \$70 million level and insisted that it would result in serious delays to the program. Regardless of the funding arrangements, the Dyna-Soar office urged approval of Titan II.<sup>28</sup> Colonel Kiessling concurred with this position and appealed to USAF headquarters. Even with the proposed low funding level, the Director of Aeronautical Systems stated employment of the Titan II promised a substantially improved Dyna-Soar program and this booster change should be immediately approved.<sup>29</sup>

Mr. Johnston and Major Halvorsen again went to Air Force headquarters. After receiving the approval of Major General M. C. Demler, Director of Aerospace Systems, the Dyna-Soar representatives informed the Strategic Air Panel of the attributes of Titan II. Discussion of the panel centered on the availability of the new booster for Step I flights, limitations of the combination Titan II and Centaur-derivative for the orbital booster, and the apparent inadequate funding level for fiscal year 1962. In spite of some doubts, the panel approved the proposed booster for Dyna-Soar I and further recommended that approximately \$150 million should be allocated for fiscal year 1962.<sup>30</sup>

At the request of Assistant Secretary Perkins, General Demler had prepared a summary on the advantages of Titan II over the earlier version. The Director of Aerospace Systems insisted that Titan I was barely sufficient for achieving the objectives of Step I and, furthermore, could not be modified to provide orbital velocities for the glider. The April 1960 development plan had stipulated that with Titan I the first unmanned ground-launch would occur in November 1963, while employment of the more powerful Titan II would only push this date back to January 1964. General Demler pointed out that if the program were limited to \$70 million, October 1964 would be the date for the first unmanned ground-launch with Titan I while December 1964 would be the date for Titan II. The aerospace director estimated that with a \$150 million level for fiscal year 1962 the development of Titan II would cost an additional \$33 million, while the cost would still be \$26 million with the \$70 million funding level. General Demler considered that the total booster cost for Step I and II employing the Titan I and then a Titan II-Centaur combination would be \$320.3 million. If Titan II were immediately used for Step I, the booster cost would be \$324.3 million. Thus the additional cost for using the more powerful booster in the first phase of the Dyna-Soar program only amounted to \$4.2 million. The conclusion was obvious; however, General Demler refrained from making recommendations.<sup>31</sup>

Following the briefing to the Strategic Air Panel, Mr. Johnston and Major Halvorsen gave the Titan II presentations to the Weapons Board. The members were familiar with the logic of General Demler's summary, and, while expressing interest in the early attainment of orbital flight, they endorsed the change to Titan II. The board recommended that Air Force headquarters immediately instruct ARDC to adopt the new booster.<sup>32</sup> However, Major General V. R. Haugen and Colonel B. H. Ferer, both in the office of the Deputy Chief of Staff for Development, decided to seek the approval of the Department of Defense. The Titan II presentations were then given to Mr. J. H. Rubel, Deputy Director of Defense for Research and Engineering. While reiterating the necessity of a \$70 million budget, Mr. Rubel agreed to the technical merits of Titan II. On January 12, 1961, Air Force headquarters announced approval of this booster for Step I flights.<sup>33</sup>

During these discussions over Titan II, it was apparent that the Department of Defense was seriously considering limiting the fiscal year 1962 figure to \$70 million. This financial restriction was confirmed on February 3 when Air Force headquarters directed the Dyna-Soar office to reorient the Step I program to conform with this lower funding level.<sup>34</sup> By the end of the month the project office and the Dyna-Soar contractors had evaluated the impact of this reduction on the program. It was clear that flight schedules would be set back almost one year.<sup>35</sup>

Apparently Department of Defense officials relented, for, on March 28, 1961, Air Force headquarters announced that the fiscal year 1962 level would be set at \$100 million. The following day Colonel W. L. Moore, Dyna-Soar Director, and his Deputy Director for Development, W. E. Lamar, reported on the status of the program to Air Force headquarters. Both Dr. Charyk and Major General Haugen directed that the program be established on a "reasonable" funding level. Colonel Moore noted that a definition of this statement was not offered.<sup>36</sup> Finally, on April 4,

headquarters of the Air Force Systems Command (AFSC) officially instructed the program office to redirect Dyna-Soar to a \$100 million level for fiscal year 1962.<sup>37</sup> \*

By April 26, 1961, the Dyna-Soar office had completed a system package program. This plan further elaborated the familiar three-step approach. Step I would involve suborbital missions of the Dyna-Soar glider boosted by the Titan II. For the research and development of this program, the Dyna-Soar office stated that \$100 million was required for fiscal year 1962, \$143.3 million for 1963, \$114.6 million for 1964, \$70.7 million for 1965, \$51.1 million for 1966, and \$9.2 million for 1967. If these funds were allotted, the first air-drop would take place in January 1964, the first unmanned ground-launch in August 1964, and the first manned ground-launch in April 1965.

The objective of Step IIA was to demonstrate orbital flight of the Dyna-Soar vehicle on around-the-world missions from Cape Canaveral to Edwards Air Force Base. The program office proposed the testing on these flights of various military subsystems such as weapon delivery and reconnaissance subsystems. Because of high cost, the Dyna-Soar office did not recommend the evaluation of a space maneuvering engine, space-to-earth missiles, or space-to-space weapons during Step IIA flights. For fiscal years 1963 through 1968, the program office estimated that this phase of Step II would total \$467.8 million and, assuming the selection of the orbital booster by the beginning of fiscal year 1962, reasoned that the first manned orbital flight could be conducted in April 1966.

---

\*On April 1, 1961, the Air Research and Development Command, by acquiring the procurement and production functions from the Air Materiel Command, was reorganized as the Air Force Systems Command. At Wright-Patterson Air Force Base, the Wright Air Development Division combined with the Aeronautical Systems Center to become the Aeronautical Systems Division (ASD).

In Step IIB, the Dyna-Soar vehicle would provide an interim operational system capable of fulfilling reconnaissance, satellite interception, space logistics, and bombardment missions. With the exception of \$300,000 necessary for an additional Step IIB study, the Dyna-Soar office did not detail the financial requirements for this phase, however, it did anticipate a Step IIB vehicle operating by October 1967. The program office looked further in the future and maintained that \$250,000 would be necessary for each fiscal year through 1964 for studies on a Step III weapon system, which could be available by late 1971.<sup>38</sup>

In the April 1961 system package program, the Dyna-Soar office outlined an extensive Category I program, consisting of structural and environmental, design, and aerothermodynamic testing, which was necessary for the development of the glider. In order to verify information obtained from this laboratory testing, the system office recommended participation in another test program which would place Dyna-Soar models in a free-flight trajectory.<sup>39</sup> The first approach which the Dyna-Soar office considered was System 609A of the Ballistic Missiles Division.

During the March 1960 review, the Aero and Space Vehicles Panel emphasized the difficulty in predicting behavior of structures utilizing coated heat shields and recommended Dyna-Soar participation in the 609A program.<sup>40</sup> The system office agreed and decided to place full-scale sections of the glider nose on four hyper-environmental flights.<sup>41</sup> \* Although subsequent planning

---

\*Models of the AVCO drag brake were also scheduled to ride 609A launches. In February 1960, Air Force headquarters had transferred the management of this project from the Directorate of Advanced Systems Technology, WADD, to the Dyna-Soar Weapon System Project Office. In March, the Air Force granted AVCO a study contract, and, in July, ARDC headquarters approved a development program for the drag brake. Air Force headquarters was reluctant to authorize funds, and the program was terminated in December. Nevertheless, in February 1961, Major General J. R. Holzapple, WADD Commander, reinstated<sup>42</sup> research on certain technical areas of the drag brake program.

reduced the number to two flights, command headquarters refused to release funds for such tests, and, consequently, Colonel Moore terminated Dyna-Soar flights in the System 609A test program on October 5. The project director gave several reasons for this decision: low probability of obtaining sufficient data with only two flights, insufficient velocity of the boosters, and high cost for Dyna-Soar participation.<sup>43</sup>

Air Force headquarters was concerned over this cancellation and emphasized to ARDC headquarters that the absence of a free-flight test program for Dyna-Soar failed to carry out assurances previously given to the Department of Defense.<sup>44</sup> The National Aeronautics and Space Administration had another approach which it had been proposing since May 1960. Dyna-Soar models constructed by both NASA and the Air Force would be placed on RVX-2A reentry vehicles and boosted by Atlas or Titan systems. Project office engineers could thereby obtain data on heat transfer and aerodynamic characteristics. By November 1960, the Dyna-Soar office was seriously considering verification of laboratory data by this RVX-2A program.<sup>45</sup>

In May 1961, Major General W. A. Davis, ASD commander, emphasized to AFSC headquarters the requirements for RVX-2A tests: funds and space on Titan II launches.<sup>46</sup> After two more appeals by the program office, Major General M. F. Cooper, Deputy Chief of Staff for Research and Engineering, gave the position of AFSC headquarters. Placing a reentry vehicle with Dyna-Soar models on the Titan II would impose several limitations on the test schedule of the booster requiring several modifications to the airframe and the launch facilities. General Cooper further stated that the \$10 million estimated by NASA officials for the RVX-2A program would necessitate approval by Air Force headquarters.<sup>47</sup> Consequently, General Cooper intended to incorporate this program in a future Dyna-Soar development plan. The RVX-2A proposal was included in a October 7, 1961 plan for the development of a Dyna-Soar weapon system; however, this program did not receive the



approval of USAF headquarters.<sup>48</sup> The attempt by the Dyna-Soar office to provide a specific program for free-flight verification of its laboratory test data ended at that point.

The April 1961 system package program also reflected changes in the Dyna-Soar flight plan. While 20 air-drop tests were still scheduled, only two unmanned ground-launches, instead of the previously planned four, were to be conducted.<sup>49</sup> On the first flight, the Titan II would accelerate the glider to a velocity of 16,000 feet per second, reaching Santa Lucia. During the second unmanned launch, the vehicle would attain a velocity of 21,000 feet per second and land near Fortaleza. Twelve manned flights were then planned with velocities ranging from 16,000 to 22,000 feet per second. If the two additional vehicles for unmanned launches were not expended, additional piloted flights would then take place.<sup>50</sup>

The scheduling of flights to Fortaleza, however, was becoming academic. As early as June 1960, Air Force headquarters notified ARDC headquarters that the State Department was concerned over the problem of renewing an agreement with Brazil for American military use of its territory.<sup>51</sup> This subject reappeared in May 1961 when the acting Director of Defense for Research and Engineering, J. H. Rubel, informed the Department of the Air Force that discussions with State Department officials indicated the difficulty, if not the impossibility, of obtaining a landing site for Dyna-Soar in Brazil.<sup>52</sup> Unless Air Force headquarters would tolerate increased costs, reduced flight test objectives, or employment of a new booster, the Dyna-Soar office thought that a landing field in Brazil was essential. The program office stated that employment of alternative landing sites would seriously affect the conduct of Category II flights and would probably prevent attainment of important research objectives.<sup>53</sup> Although Dr. Brockway McMillan, Assistant Secretary of the Air Force for Research and Development, reiterated this position to the Department of Defense, the subject of a Fortaleza landing site did not assume a greater significance because the Air Force was already seriously questioning the need for suborbital flight.<sup>54</sup>

From January 1960 through April 1961, the Dyna-Soar program office had defined the three-step program and had implemented the suborbital phase. While Air Force headquarters had approved the April 1960 development plan, it had not sanctioned the more detailed April 1961 system package program. The reason for this suspended action was apparent. The Dyna-Soar office was engaged in a study which promised to eliminate suborbital flight, accelerate the date for the first manned orbital launch, and, consequently, radically alter the three-step approach.

## NOTES

1. Rpt., Aero & Space Vehicles Panel, SAB, Jan. 1960, subj.: Dyna-Soar.
2. Memo., J. V. Charyk, ASAF/Res. & Dev., to DCS/Dev., Hqs. USAF, 4 Jan. 1960, subj.: Dyna-Soar "Phase Alpha" Program.
3. DSM WAR, 18 Dec. 1959, 15 Jan. 1960; TWX, RDZSXB-30061-E, Hqs. WADD to Hqs. ARDC, 20 Jan. 1960.
4. TWX, RDZSXB-1-1420-E, Hqs. WADD to Hqs. ARDC, 28 Jan. 1960.
5. DSM WAR, 5 Feb. 1960.
6. Ltr., Lt. Gen. B. A. Schriever, Cmdr., ARDC to Lt. Gen. S. E. Anderson, Cmdr., AMC, 5 Dec. 1959, subj.: Management of Dyna-Soar Project; memo., Hqs. ARDC and Hqs. BMD, subj.: Statement of Agreement, System 620A, Dyna-Soar I, for the Air Force Ballistic Missiles Division, ARDC.
7. Ltr., Lt. Gen. S. E. Anderson, Cmdr., AMC to Lt. Gen. B. A. Schriever, Cmdr., ARDC, 11 Dec. 1959, subj.: Management of the Dyna-Soar Program.
8. Memo., Lt. Gen. S. E. Anderson, Cmdr., AMC and Lt. Gen. B. A. Schriever, Cmdr., ARDC, subj.: AMC and ARDC Management Procedures for the Dyna-Soar Program, 8 Feb. 1960.
9. Ltr., Brig. Gen. H. A. Boushey, Asst/Adv. Tech., DCS/Dev., Hqs. USAF to Hqs. ARDC, 15 Jan. 1960.
10. Ltr., Col. W. R. Grohs, Vice Cmdr., WADD to Dep/Adv. Sys., DSM, WADD, 27 Jan. 1960, subj.: Formation of Ad Hoc Group for Dyna-Soar.
11. DSM WAR, 5 Feb. 1960; interview, C. B. Hargis, Asst. Dep. Dir/Dev., Dyna-Soar SPO, ASD by C. J. Geiger, Hist. Div., ASD, 10 May 1963; presn., W. E. Lamar, Dep. Dir/Dev., Dyna-Soar SPO, ASD to Hqs. AFSC, 20 Feb. 1963, subj.: History of Dyna-Soar (X-20) to Present.
12. Rpt., Aero & Space Vehicles Panel, SAB, 15 Apr. 1960, subj.: Dyna-Soar and Phase Alpha Review.
13. System Development Plan, Dyna-Soar (Step I) Program, 620A, Dyna-Soar WSP0, WADD, 1 Apr. 1960, pp. III-8 to III-12, III-49 to III-52, III-65 to III-72, III-195 to III-207; System Package Program, System 620A, Dyna-Soar SPO, ASD, 26 Apr. 1961, pp. 84-92, 132-139, 182-187.
14. System Development Plan, Dyna-Soar (Step I) Program, 620A, Dyna-Soar WSP0, WADD, 1 Apr. 1960, pp. III-1 to III-2, III-267 to III-272, IV-1 to IV-2, V-i, VIII-1, IX-1.

15. DSM WAR, 8, 16 Apr. 1960.
16. TWX, AFDAT-89082, Hqs. USAF to Hqs. ARDC, 26 Apr. 1960.
17. SDR 19, Hqs. USAF, 21 July 1960.
18. Ltr., Dyna-Soar WSPO, WADD, to Hqs. ARDC, subj.: Dyna-Soar Step II and Step III Funding, 2 Aug. 1960.
19. TWX, WWZRM-8-1041-E, Hqs. WADD to Hqs. ARDC, 23 Aug. 1960.
20. Memo., Col. E. A. Kiessling, Dir., Aero. Sys., Hqs. ARDC, 27 Sept. 1960, subj.: Dyna-Soar Step II and Step III Funding.
21. Ltr., Col. Kiessling, Hqs. ARDC to Hqs. WADD, subj.: WADD Dyna-Soar Step II and Step III Funding, 4 Oct. 1960.
22. DD 411, Hqs. USAF, 12 Oct. 1960.
23. Rpt., Dyna-Soar SPO, ASD, Dec. 1962, subj.: Evaluation of the Dyna-Soar Step IIA and Step IIB Studies, pp. 1, 11.
24. SSD, Hqs. ARDC, 6 Dec. 1960, subj.: Dyna-Soar Step III Study.
25. TWX, AFDAP-78950, Hqs. USAF to Hqs. AFSC, 16 June 1961; TWX, SCLDA-8-1-2-E, Hqs. AFSC to Hqs. ASD, 8 Jan. 1962.
26. TWX, AFSDS-66668, Hqs. USAF to Hqs. ARDC, 5 Dec. 1960.
27. Memo., R. C. Johnston, Ch., Booster Br., Dyna-Soar WSPO, WADD, 27 Dec. 1960, subj.: Record of Presentations on Proposed Use of Titan II as a Dyna-Soar Booster.
28. TWX, WWZR-5-1-1081, Hqs. WADD to Hqs. ARDC, 5 Jan. 1961.
29. TWX, RDRAS-6-1-8, Hqs. ARDC to Hqs. USAF, 6 Jan. 1961.
30. Memo., R. C. Johnston, Ch., Booster Br., Dyna-Soar WSPO, WADD, 12 Jan. 1961, subj.: Trip Report to Hqs. USAF, 9-11 Jan. 1961, Titan II Booster Presentation.
31. Rpt., Maj. Gen. M. C. Demler, Dir., Aerospace Sys. Dev., DCS/Dev., Hqs. USAF, subj.: System 620A, Dyna-Soar (Step I) Booster.
32. Memo., R. C. Johnston, Ch., Booster Br., Dyna-Soar WSPO, WADD, 12 Jan. 1961, subj.: Trip Report to Hqs. USAF, 9-11 Jan. 1961, Titan II Booster Presentation.
33. Ibid.; TWX, AFSDS-76644, Hqs. USAF to Hqs. ARDC, 12 Jan. 1961.
34. TWX, AFSDS-82107, Hqs. USAF to Hqs. WADD, 3 Feb. 1961.

35. DSM WAR, 3 Mar. 1961.
36. Trip Rpt., Col. W. L. Moore, Jr., Dir., Dyna-Soar SPO, WADD to Brig. Gen. A. T. Culbertson, Dir., Sys. Mangt., WADD, 31 Mar. 1961, subj.: Presentation on Status of Dyna-Soar Program.
37. TWX, SCRAS-3-4-2, Hqs. AFSC to Hqs. ASD, 4 Apr. 1961.
38. System Package Program, System 620A, Dyna-Soar SPO, ASD, 26 Apr. 1961, pp. 42, 411, 446-447, 454, 460-474, 487a, 489-490, 502, 510, 519, 522.
39. Ibid., p. 189.
40. Rpt., Aero & Space Vehicles Panel, SAB, 15 Apr. 1960, subj.: Dyna-Soar and Phase Alpha Review.
41. Memo., W. E. Lamar, Ch., Dir. Sys. Engg., Dyna-Soar WSPO, WADD, subj.: Conference at NASA Regarding RVX-2 Test for Dyna-Soar; System Development Plan, Dyna-Soar (Step 1) Program, 620A, Dyna-Soar WSPO, WADD, 1 Apr. 1960, p. III-77; TWX, WWZRB-23-8-1017, Hq. WADD to Hqs. BMD, 23 Aug. 1960.
42. Ltr., Col. W. L. Moore, Jr., Ch., Dyna-Soar WSPO, WADD to J. A. Boykin, DSM, WADD, 1 Feb. 1960, subj.: AVCO Drag Brake Project; TWX, WWZRB-6-4-E, Hqs. WADD to Hqs. BMD, 14 June 1960; memo., J. B. Trenholm, Jr., Asst. Dir., Dyna-Soar SPO, WADD, 21 Feb. 1961, subj.: AVCO Drag Brake-Project 6065; ltr., C. B. Hargis, Jr., Asst. Ch., Dyna-Soar WSPO, WADD to Hqs. BMD, 1 Apr. 1960, subj.: AVCO Drag Brake Program, Booster Data, and Availability Requirements; DSM WAR, 1 Apr. 1960, 1 July 1960, 2 Aug. 1960, 2 and 16 Sept. 1960, 6 Jan. 1961; TWX, RDRAS-14-12-26, Hqs. ARDC to Hqs. WADD, 14 Dec. 1962.
43. Ltr., Col. W. L. Moore, Jr., Ch., Dyna-Soar WSPO, WADD to Hqs. ARDC, 5 Oct. 1960, subj.: Dyna-Soar HETS Program.
44. TWX, AFSDS-AS/0-93477, Hqs. USAF to Hqs. ARDC, 13 Oct. 1960.
45. Memo., W. E. Lamar, Ch., Dir. Sys. Engg., Dyna-Soar WSPO, WADD subj.: Conference at NASA Regarding RVX-2 Test for Dyna-Soar; memo., NASA, 4 Nov. 1960, subj.: The Atlas-RVX-2 and Communications Experiments Program Proposed by NASA; TWX, WWDR-7-11-2, Hqs. WADD to Hqs. ARDC, 8 Nov. 1960.
46. Ltr., Maj. Gen. W. A. Davis, Cmdr., ASD to Hqs. AFSC, subj.: Aeronautical Systems Division Free Flight Environmental Test Program, 2 May 1961.
47. Ltr., Maj. Gen. M. F. Cooper, DCS/Res. & Engg., Hqs. AFSC to Dr. I. H. Abbott, Dir., Adv. Res. Prog., NASA, 28 June 1961, subj.: Dyna-Soar Reentry Research Program.

48. Abbreviated Development Plan, System 620A, Dyna-Soar SPO, ASD, 7 Oct. 1961, subj.: Manned Military Space Capability, p. 64.
49. Memo., W. M. Ritchey, Asst. Test Force Dir., Dyna-Soar WSPO, WADD, 1 Nov. 1960, subj.: Meeting to Consider System Development Test Approach; DSM WAR, 4 Nov. 1960.
50. System Package Program, System 620A, Dyna-Soar SPO, ASD, 26 Apr. 1961, pp. 306-307.
51. TWX, RDROF-9-6-4, Hqs. ARDC to Hqs. WADD, 9 June 1960.
52. Memo., J. H. Rubel, Acting DDR&E, DOD to SAFUS, 3 May 1961, subj.: Dyna-Soar Landing Site in Brazil, in files Dyna-Soar Sys. Staff Ofc., DCS/Sys. & Log., Hqs. USAF.
53. TWX, WWZRT-25-5-1079, Hqs. ASD to Hqs. USAF, 25 May 1961.
54. Memo., Brockway McMillan, ASAF/Res. & Dev. to DDR&E, DOD, 12 June 1961, subj.: Dyna-Soar Landing Site in Brazil, in files of Dyna-Soar Sys. Staff Ofc., DCS/Sys. & Log., Hqs. USAF.

## CHAPTER IV

### REDIRECTION

When Brigadier General M. B. Adams, Deputy Director of Systems Development in Air Force headquarters, forwarded Development Directive 411 in October 1960, he initiated a series of studies which eventually resulted in a redirection of the Dyna-Soar program. General Adams instructed the Air Research and Development Command to formulate a "stand-by" plan for achieving orbital flight with the Step I glider at the earliest possible date.<sup>1</sup> In December, the Dyna-Soar office was ready with such a proposal. By merging Steps I and IIA into a continuous development and employing an orbital booster for both suborbital and orbital flights, the time for the first manned orbital launch could be accelerated by as much as 17 months over the three-step schedules.<sup>2</sup>

Depending on either a March 1961 or a November 1961 approval date, Dyna-Soar officials estimated that by using a Titan II in combination with a Centaur derivative, the program would cost either \$726 million or \$748 million. If Saturn C-1 was designated, the figures would be \$892 million or \$899 million. The total, however, for a separate suborbital Step I and an orbital Step IIA would approximate \$982.6 million. This financial difference between "stand-by" and the three-step approach stemmed from the employment of the same booster for both suborbital and orbital flights. The Dyna-Soar office favored this accelerated approach and recommended that ARDC headquarters immediately approve "stand-by."<sup>3</sup> Command headquarters did not agree and took the position that "stand-by" would only be approved when the international situation necessitated a higher priority and additional funds for Dyna-Soar.<sup>4</sup>

The logic of employing the same booster for Steps I and IIA pointed to a further conclusion. On May 4, 1961, Boeing officials proposed another plan for acceleration. This "streamline" approach encompassed the elimination of suborbital flight, temporary employment of available subsystems, and the use of Saturn C-1. Assuming a June 1961 approval date, Boeing representatives anticipated the first unmanned orbital flight to occur in April 1963, instead of August 1964 as scheduled in the three-step approach.<sup>5</sup>

Temporary subsystems would only decrease system reliability, the program office reasoned, and, consequently, Boeing's proposal was not entirely acceptable. Dyna-Soar officials considered that the key to accelerating the orbital flight date was not only the question of booster availability, but also the time required to develop the various glider subsystems. If funding for fiscal year 1962 were increased, it would be possible to accelerate the glider schedules and advance the orbital flight date.

By the end of June, the program office had refined Boeing's original plan. The first phase, "streamline," involved the development of an orbital research vehicle. The purpose of the second phase was the development and testing of military subsystems with the final phase resulting in an operational weapon system. Either a modified Saturn booster, a Titan II with a hydrogen-oxygen second stage, or a Titan II augmented by solid propellant engines, was acceptable for the "streamline" phase. The program office now estimated that this phase would cost a total of \$967.6 million, with the first unmanned orbital flight occurring in November 1963.<sup>6</sup>

While the Dyna-Soar office was considering ways to accelerate the orbital flight date of its glider, the newly established Space Systems Division (SSD) completed, on May 29, 1961, two development



plans for demonstrating orbital and far-earth orbital flight of a lifting body design. Essentially, the objective of the Advanced Reentry Technology program (ART) was to determine whether ablative or radiative heat protection was more feasible for lifting reentry.<sup>7</sup> The second program advanced by SSD was a manned satellite inspector proposal, SAINT II.

The space division had under its cognizance a SAINT I program, the purpose of which was the development of an unmanned prototype, inspector vehicle. The SAINT II proposal involved the development of a manned vehicle, capable of achieving precise orbital rendezvous and fulfilling space logistic missions. This lifting body would be able to maneuver during reentry and accomplish conventional landing at a preselected site. Officials of the space division listed several reasons why the Dyna-Soar configuration could not, in their opinion, accomplish SAINT II missions. The reentry velocity of Dyna-Soar could not be significantly increased because of the inadaptability of this configuration to ablative heat protection. Furthermore, winged-configurations did not permit sufficient payload weights and incurred structural penalties to the booster. Finally, rendezvous and logistic missions would require prohibitive modifications to the Dyna-Soar glider.

The proposed SAINT II demonstration vehicle was to be a two-man lifting, reentry craft launched by a Titan II and Chariot combination. This Chariot upper stage would employ fluorine and hydrazine propellants and would produce 35,000 pounds of thrust. The vehicle would be limited to 12,000 pounds, but, with approval of an Air Force space launch system, the weight could be increased to 20,000 pounds. Twelve orbital demonstration launches were scheduled, with the first unmanned flight occurring early in 1964 and the initial manned launches taking place later that year. From fiscal year 1962 through 1965 this program would require \$413.9 million.<sup>8</sup>

After examining the space division proposal and the Dyna-Soar plan for acceleration, General B. A. Schriever, AFSC commander, deferred a decision on Dyna-Soar until the relationship between "streamline" and SAINT II was clarified. Moreover, further analysis of an orbital booster for Dyna-Soar would have to be accomplished.<sup>9</sup>

From May 1 through 12, 1961, a Dyna-Soar technical evaluation board, composed of representatives from the Air Force Systems Command, the Air Force Logistics Command (AFLC), and the National Aeronautics and Space Administration, had considered 13 proposals for orbital boosters from the Convair Division, the Martin Company and NASA. The evaluation board decided that the Martin C plan was the most feasible approach. The first stage of this liquid booster consisted of an LR87-AJ-5 engine, capable of producing 430,000 pounds of thrust, while the second stage, with a J-2 engine, could deliver 200,000 pounds of thrust.<sup>10</sup>

The Dyna-Soar Directorate of the Space Systems Division, having the responsibility for developing boosters for System 620A, also made a recommendation on the Step IIA propulsion. On July 11, Colonel Joseph Pellegrini informed the Dyna-Soar office that his directorate favored employment of the projected Space Launch System A388. This proposal was an outgrowth of an SSD study on a Phoenix series of varying combinations of solid and liquid boosters to be used in several Air Force space missions. Phoenix A388 was to have a solid first stage, which could produce 750,000 pounds of thrust, and a liquid propellant second stage, using the J-2 engine.<sup>11</sup>

On August 3 and 4, 1961, Colonel Walter L. Moore, Jr., director of the Dyna-Soar program, brought the "streamline" proposal before the Strategic Air Panel, the Systems Review Board, and the Vice Chief of Staff. The program director pointed out that by eliminating suborbital flight the first air-drop would occur in

mid-1963; the first unmanned orbital flight in 1964; and the first piloted orbital launch in early 1965. In comparison, the first piloted Step IIA flight had been scheduled for January 1967. Not only would the orbital flight date be accelerated, but considerable financial savings would also accrue. Colonel Moore now estimated that the combined cost of Steps I and IIA was projected at \$1.201 billion, while the figure for "streamline" would run \$1.026 billion. The director concluded by emphasizing that Dyna-Soar provided the most effective solution to an Air Force manned space program, and "streamline" was the most expeditious approach to piloted orbital flight.<sup>12</sup>

Officials from SSD and the Aerospace Corporation presented their considerations for a "streamline" booster. At this point it was clear that previous SSD evaluations for a Step IIA booster were simply incorporated in the "streamline" analysis. The first choice of Aerospace and SSD officials was again their proposed Phoenix space launch system. Assuming a November 1961 approval date, Phoenix A388 allowed the first unmanned launch to occur in July 1964, and, based on an 18-flight Dyna-Soar program, the cost for Phoenix development from fiscal year 1962 through 1966 would total \$183.3 million. The second option was the Soltan, derived by attaching two 100-inch diameter solid propellant engines to the Titan II. The projected Soltan schedule permitted the same launch date as the Phoenix, but the cost was estimated at \$325.4 million. Although the Saturn C-1 allowed an unmanned launch date in November 1963 and the cost would total \$267.2 million, this booster was the third choice, largely because it was deemed less reliable. The space division representatives then concluded their part of the presentation by discussing the merits of ART and SAINT II.<sup>13</sup>

The Assistant Secretary of the Air Force for Research and Development, Dr. Brockway McMillan, was not as enthusiastic for acceptance of the Phoenix system. While he did not recommend use

of the Saturn, Dr. McMillan thought that the Air Force should seriously consider the fact that the big NASA booster would provide the earliest launch date for Dyna-Soar. The assistant secretary believed, however, that an Atlas-Centaur combination would be the most feasible space launch vehicle for 10,000 pound payloads through 1965. After this time period, Dr. McMillan favored Soltan.<sup>14</sup>

Prior to these briefings, General Schriever was already convinced that Dyna-Soar had to be accelerated. He further believed that the best selection for the booster was Phoenix A388.<sup>15</sup> On August 11, he informed ASD, SSD, and his Deputy Commander for Aerospace Systems, Lieutenant General H. M. Estes, Jr., that "streamline" had the approval of AFSC headquarters and had to be "vigorously supported" by all elements of the command. Yet, the acceleration of Dyna-Soar was not that simple. The AFSC commander was still concerned over the duplication of the manned SAINT proposal and an orbital Dyna-Soar. He stated that these plans constituted a complex, and, at that point, an indefinable approach to military space flight which could not be presented to USAF headquarters. Consequently, General Schriever directed that a Manned Military Space Capability Vehicle study be completed by September. This proposed program would consist of "streamline," and a Phase Beta study which would determine vehicle configuration, boosters, military subsystems, and missions for an operational system which would follow Dyna-Soar. General Schriever also directed that the applied research programs of his command be reviewed to assure contributions to Dyna-Soar and far-earth orbital flights.<sup>16</sup>

During an August 1961 meeting of the Designated Systems Management Group, the Secretary of the Air Force, Eugene M. Zuckert, commented on the question of Dyna-Soar

acceleration.\* He directed the three-step approach to continue until the position of Dyna-Soar in a manned military space program was determined. Within the confines of the \$100 million fiscal year 1962 budget, the secretary stated that action could be taken to facilitate the transition from a Step I to a "streamline" program. Finally, he requested a study on various approaches to manned military orbital flight.<sup>18</sup>

Under the direction of General Estes, a committee was formed in mid-August 1961 with representation from the Air Force Systems Command, RAND, MITRE, and the Scientific Advisory Board for the purpose of formulating a manned military space plan. The work of the committee was completed by the end of September with diverse sets of recommendations.

---

\*In early April 1961, Lieutenant General R. C. Wilson, Deputy Chief of Staff for Development, appeared concerned with the management of Air Force headquarters over the Dyna-Soar program. Although the Air Staff had devoted considerable attention to this program, it had not always been successful in affecting the decisions of the Secretary of the Air Force or the Secretary of Defense. General Wilson indicated to General C. E. LeMay, the Vice Chief of Staff, that this situation could be alleviated if the program were placed under the management of the Air Force Ballistic Missile and Space Committee. General LeMay, on May 5, concurred and pointed out that the Department of the Air Force would have to place increasing emphasis on Dyna-Soar because it was a system leading to manned space flight. Dr. J. V. Charyk, the Air Force under secretary, disagreed and thought that since Dyna-Soar was primarily a research project, transfer of the management in the department should be deferred until a Dyna-Soar weapon system was under development. On July 25, the Secretary of the Air Force replaced the ballistic and space committee with the Designated Systems Management Group. Composed of important officials in the Department of the Air Force, this group was to assist the Secretary of the Air Force in managing significant programs. By August 1, 1961, the Dyna-Soar program was listed as one of the systems under the jurisdiction of the designated management group.<sup>17</sup>

One of the working groups, chaired by a representative from the Aerospace Corporation, favored terminating the Dyna-Soar program and redirecting Boeing's efforts to the development of a lifting body. Such an approach would cost \$2 billion. A second alternative was to accelerate a suborbital Dyna-Soar program, cancel the orbital phase, and initiate studies for far-earth, orbital flights. This proposal would total \$2.6 billion. The least feasible approach, this group considered, was to implement "streamline," and initiate a Phase Beta. Such a program would be the most expensive, totalling \$2.8 billion.<sup>19</sup>

The opposite position was assumed by a panel of Scientific Advisory Board members, chaired by Professor C. D. Perkins, which strongly supported the last alternative of the Aerospace group. The Perkins group thought that military applications of a lifting body approach did not offer more promise than Dyna-Soar. To emphasize this point, the group questioned the control characteristics of a lifting body design which could make the execution of conventional landings hazardous. The group further argued that "streamline" should be directed towards defining military space objectives and insisted that a Phase Beta and an applied research program should be undertaken before considering an advanced Dyna-Soar vehicle.<sup>20</sup>

General Estes reached his own conclusions about a manned military space study. "Streamline" should receive Air Force approval; however, it should have unquestionable military applications, namely satellite inspection and interception missions. The deputy commander doubted that a Dyna-Soar vehicle could accomplish far-earth orbital flights and undergo the resulting reentry velocity, ranging from 35,000 to 37,000 feet per second, and, consequently, he firmly stated that a Phase Beta study, conducted by Boeing, was necessary to determine a super-orbital design for Dyna-Soar.<sup>21</sup>

Secretary of Defense Robert S. McNamara also made a pronouncement on Dyna-Soar. After hearing presentations on the program and the military space proposal of SSD, the secretary seriously questioned whether Dyna-Soar represented the best expenditure of national resources.<sup>22</sup> From this encounter with the defense department, the Air Staff derived a concept which was to dominate the Dyna-Soar program. Before military applications could be considered, the Air Force would have to demonstrate manned orbital flight and safe recovery.<sup>23</sup>

During a meeting of the Designated Systems Management Group in early October 1961, it was very clear that the Air Force had decided in favor of "streamline." The management group had severely criticized SAINT II by insisting that the projected number of flight tests and the proposed funding levels were too unrealistic. As a result of this review, the Department of the Air Force prohibited further use of the SAINT designation.<sup>24</sup>

Dyna-Soar officials completed, on October 7, 1961, an abbreviated development plan for a manned military space capability program. The plan consisted of "streamline;" a Phase Beta study, which would determine approaches to the design of a super-orbital Dyna-Soar vehicle; supporting technological test programs; and an applied research program. The objectives of the proposed Dyna-Soar plan were to provide a technological basis for manned maneuverable orbital systems; determine the optimum configuration for super-orbital missions, and demonstrate the military capability of both orbital and super-orbital vehicles.

The program office considered the Phoenix system acceptable but derived, instead, a new two-step program based on the employment of Titan III, which differed from Soltan by using two 120-inch diameter solid propellant engines. While Dyna-Soar I would encompass the "streamline" proposal, Dyna-Soar II would involve the

development of a far-earth, orbital vehicle. The program office anticipated the first unmanned orbital flight in November 1964, and the first piloted flight in May 1965. The next five flights would be piloted with the purpose of accomplishing multiorbital missions. The ninth flight test, occurring in June 1966, however, would be an unmanned exploration of super-orbital velocities. The remaining nine flight tests would be piloted, with the purpose of demonstrating military missions of satellite interception and reconnaissance. The flight test program was to terminate by December 1967.

To accomplish this program, the Dyna-Soar office considered that \$162.5 million would be required for fiscal year 1962, \$211.7 million for 1963, \$167.4 million for 1964, \$168.6 million for 1965, \$99.0 million for 1966, \$21.0 million for 1967, and \$2.4 million for 1968. With \$88.2 million expended prior to fiscal year 1962, these figures would total \$921 million for the development of a manned military Dyna-Soar vehicle.<sup>25</sup>

On October 15, 1961, Colonel B. H. Ferer of the Dyna-Soar system staff office, USAF headquarters, requested W. E. Lamar, Deputy Director for Development in the Dyna-Soar office, to brief Dr. Brockway McMillan and a military manned spacecraft panel, convened to advise the Secretary of Defense. Mr. Lamar gave a comprehensive narrative of the history of Dyna-Soar and its current status to the assistant secretary. While Dr. McMillan approved the briefing as suitable for the spacecraft panel, he requested Mr. Lamar not to emphasize military applications at that time. The briefing to the panel followed, but Colonel Ferer once again called Lamar. The deputy for development was rescheduled to brief Dr. L. L. Kavanau, Special Assistant on Space in the Department of Defense. Dr. Kavanau appeared quite interested in the various alternatives to accelerating Dyna-Soar and finally stated that it was sensible to go directly to an orbital booster.<sup>26</sup>



Based on the October proposal, General Estes prepared another development plan for Dyna-Soar. This approach was presented in a series of briefings to systems command headquarters, the Air Staff, and, on November 14, to the Designated Systems Management Group.<sup>27</sup> The central objective was to develop a manned, maneuverable vehicle, capable of obtaining basic research data, demonstrating reentry, testing subsystems, and exploring man's military function in space. These objectives were to be achieved by adapting the Dyna-Soar glider to a Titan III booster in place of the previously approved suborbital Titan II.\*

The Dyna-Soar office considered two alternate funding plans. Plan A adhered to the established \$100 million ceiling for fiscal year 1962, set \$156 million for 1963, and required \$305.7 million from 1964 through 1967. Total development funds would amount to \$653.4 million and would permit the first unmanned ground-launch by November 1964. Plan B followed the ceilings of \$100 million for fiscal year 1962 and \$125 million for fiscal year 1963. Under this approach, \$420.2 million would be required from 1964 through 1968, totalling \$736.9 million. This latter plan established April 1965 as the earliest date for the first unmanned ground-launch. Regardless of which approach was taken, the proposed program would substantially accelerate the first manned orbital flight from 1967 to 1965.<sup>29</sup>

On December 11, 1961, Air Force headquarters informed the systems command that the Secretary of the Air Force had agreed to accelerate the Dyna-Soar program. The suborbital phase of the old three-step program was eliminated, and the central objective was the early attainment of orbital flight, with the Titan III booster. Plan B of the November 1961 development plan was accepted, and

---

\*While accepting the standard space launch concept, the Department of Defense decided against the employment of a Phoenix system and, on October 13, informed Dr. McMillan that Titan III was to be the Air Force space booster.<sup>28</sup>

\$100 million for fiscal year 1962 and \$125 million for 1963 was stipulated. Finally, the Air Staff instructed the Dyna-Soar office to present a new system package program to headquarters by early March 1962.<sup>30</sup>

Colonel Moore set the following tentative target dates to be considered in reorienting the program: the first air-launch in July 1964; the first unmanned orbital ground-launch in February 1965; and the first manned orbital ground-launch in August 1965. The program director commented that the advancement of the program to an orbital status represented a large step toward meeting the overall objectives of Dyna-Soar.<sup>31</sup>

The program office then issued instructions to its contractors, the Boeing Company, the Minneapolis-Honeywell Regulator Company, and the Radio Corporation of America, pertaining to the redirected program. The tentative dates offered by Colonel Moore were to be used as guidelines for establishing attainable schedules. The Dyna-Soar glider was to be capable of completing one orbit with all flights terminating at Edwards Air Force Base, California. The system office informed the contractors that no requirements existed for maneuvering in space nor for the development of military subsystems. The contractors were to make only a minimum number of changes to the glider and the transition section in order to adapt the airframe to the Titan IIIC. To conform to budget restrictions, a serious reduction in program scope was necessary. Certain wind tunnel tests would have to be suspended. The air-launch program would consist of only 15 drops from a B-52 and would terminate in April 1965. The first two ground-launches were to be unmanned, and the remaining eight were to be piloted.<sup>32</sup>

On December 27, 1961, the Deputy Chief of Staff for Systems and Logistics, USAF headquarters, issued System Program Directive 4, which reiterated the program objective announced in the

November 1961 development plan. The deputy chief of staff emphasized the Air Force view that man would be required to perform missions essential to national security in space. The Dyna-Soar program would provide a vehicle which offered an economical and flexible means to return to a specific landing site, and, consequently, would fulfill a vital military need not covered in the national space program. The directive specified that Titan IIC was to be the booster, and that only single orbits were contemplated for each ground-launch. Although Air Force headquarters chose the low funding level of Plan B, \$100 million for fiscal year 1962 and \$115 million for 1963, headquarters also insisted on the accelerated flight dates of Plan A.\* The deputy chief of staff would accept later flight dates only if an examination by the systems command revealed the impossibility of achieving such a schedule. Lastly, a new system package program had to be completed by March 1962.<sup>33\*\*</sup>

To give further legal sanction to the redirected program, Air Force headquarters, on February 21, 1962, issued an amendment to the advanced development objective, dated July 21, 1960.\*\*\* This amendment deleted references to suborbital flights and to the

---

\*The flight schedule of Plan A in the November 1961 development plan stipulated April 1964 for the air-launch program, November 1964 for the unmanned ground-launch, and May 1965 for the manned ground-launch.

\*\*Major General W. A. Davis, ASD commander, protested that the March 1962 date was an arbitrary limitation and did not allow the system office enough time to reshape the program. Air Force headquarters apparently received this recommendation favorably because, on February 2, 1962, the Deputy Chief of Staff for Systems and Logistics issued an amendment to the system program directive of December 27, 1961, extending the completion date of a new system package program to the middle of May 1962.<sup>34</sup>

\*\*\*This advanced development objective had been previously designated System Development Requirement 19, issued on July 21, 1960.

development of military subsystems. Air Force headquarters, however, did state that a reliable method for routine recovery of space vehicles would make military missions practical. The amendment further stipulated that the program was oriented to single orbital flights, with the first unmanned ground-launch occurring in November 1964.<sup>35</sup>

In a memorandum of February 23, 1962, Secretary McNamara officially endorsed the redirection of the Dyna-Soar program. He directed the termination of the suborbital program and the attainment of orbital flight by employment of the Titan IIIC booster. The funding level was limited to \$100 million in fiscal year 1962 and \$115 million in 1963. Finally, Secretary McNamara insisted on a redesignation of the Dyna-Soar program to a nomenclature more suitable for a research vehicle.<sup>36</sup>

By the end of February, a draft version of the system package program was completed, and, in the middle of March, the program office offered the preliminary outlines to AFSC and Air Force headquarters. The central point of this briefing was that the \$115 million fiscal year 1963 ceiling would endanger the attainment of desired system reliability and would also limit the flight profile of the glider. As a result of these presentations, Air Force headquarters instructed the systems command to prepare a briefing for the Department of Defense.<sup>37</sup>

On April 17, officials of the Dyna-Soar office made a presentation to Dr. Harold Brown, Director of Defense for Research and Engineering. The program office wanted approval of a \$12.2 million increase for fiscal year 1963 and, also, an additional \$16.7 million to realize an unmanned ground-launch date of May 1965. Dr. Brown offered to give both proposals further consideration and requested the Dyna-Soar office to present alternative funding levels to meet a May or July 1965 unmanned launch date.<sup>38</sup>

By April 23, 1962, the system package was completed. The objective of the new Dyna-Soar program had been clearly announced by the November 1961 development plan and was reiterated in this more elaborate proposal. Dyna-Soar was a research and development program for a military test system to explore and demonstrate maneuverable reentry of a piloted orbital glider which could execute conventional landing at a preselected site. For the Dyna-Soar office, the new program represented a fundamental step towards the attainment of future piloted military space flight.

Prior to redirection in December 1961, the Dyna-Soar system office had final authority over the Step I booster being developed by the space division. Under the new program, however, the Dyna-Soar glider would only be one of the payloads for the standard space launch system, designated 624A. Titan IIIA formed the standard core and was essentially a modified Titan II with a transtage composed of an additional propulsive unit and a control module. This version of the standard launch system, although it had no assigned payload, as yet, was capable of placing 7,000 pounds into an orbit of 100 nautical miles. The Dyna-Soar glider, however, was scheduled to ride the Titan IIIC booster. This launch system was derived from the standard core with an attached first-stage of two, four-segment, solid, rocket motors, capable of delivering a total of 1,760,000 pounds of thrust.\* The second and third stages were liquid propulsive units and would produce 474,000 and 100,000 pounds of thrust, respectively. Titan IIIC could place a maximum of 25,000 pounds in low-earth orbit, however, for the particular Dyna-Soar trajectory and conditions, the payload capability was 21,000 pounds.<sup>40</sup>

---

\*Late in May 1962, the Assistant Secretary McMillan requested the Dyna-Soar office to investigate the impact of employing a five-segment Titan IIIC on the program. Although this change would necessitate glider modifications amounting to \$5.4 million, the program office recommended that the five-segment configuration be selected for Dyna-Soar, and command headquarters concurred on July 25.<sup>39</sup>

The flight test program was defined in three phases. One Dyna-Soar glider was now scheduled to accomplish 20 air-launches from a B-52C aircraft to determine glider approach and landing characteristics, obtain data on lift-to-drag ratio and flight characteristics at low supersonic velocities, and accumulate information on the operation of the glider subsystems. On four of the air-launches, the acceleration rocket would power the glider to a speed of Mach 1.4 and a height of 70,000 feet.

Following the air-launch program, two unmanned orbital launches would occur. The purpose was to verify the booster-glider system as a total vehicle for piloted flight, and demonstrate glider-design for hypersonic velocities. The Titan IIIC would propel the glider to a velocity of 24,490 feet per second, and after fulfilling its orbital mission, the vehicle would land at Edwards Air Force Base by employment of the drone-landing techniques. Eight piloted orbital flights were to follow, further exploring and defining the Dyna-Soar flight corridor.

According to the reasoning of the Dyna-Soar office, the first air-launch would occur in September 1964, with the final drop taking place in July 1965. The first unmanned ground-launch was to be conducted in May 1965, with the second unmanned flight occurring in August 1965. The first piloted flight was scheduled for November 1965 and the last manned orbital mission for the beginning of 1967. The Dyna-Soar office had hopefully attempted to obtain the earliest possible launch dates and still remain within the \$115 million fiscal year 1963 ceiling set by USAF headquarters on December 27, 1961.<sup>41</sup>

On April 25, 1962, General Davis forwarded the system package program for the approval of AFSC headquarters. In line with Dr. Brown's request for alternative funding proposals, the Dyna-Soar office submitted a more realistic funding schedule. To

meet a May 1965 schedule for the first unmanned launch, \$144.8 million was required for fiscal year 1963 and \$133.1 million for 1964. If the first unmanned launch was to occur in July 1965, then \$127.2 million was needed for fiscal year 1963 and \$133.1 million for 1964.<sup>42\*</sup>

Following completion of the system package program, a series of presentations were made to elements of AFSC headquarters, Air Force headquarters and the Department of Defense. To remain within the \$115 million fiscal year 1963 ceiling, the Dyna-Soar office was forced to reduce the development test program, thereby decreasing the reliability of the glider system and limiting the scope of the flight test program. During one of the briefings to the Department of Defense, Dr. Brown recommended significant changes to the Dyna-Soar program. Additional funds would be allotted for further development testing, and most important, the Dyna-Soar glider was to fulfill multiorbit missions.<sup>44</sup>

On May 14, the program office had completed a revision of its system package. The wind tunnel program was expanded. Glider and panel flutter tests were added. Work to increase the heat

---

\*General Davis also pointed out that the Pacific Missile Range of the Department of the Navy had issued a financial requirement of \$100 million for the construction of four vessels which would be employed in the Dyna-Soar program. The ASD commander emphasized that other space programs would eventually use these facilities, and, consequently, this cost should not be fully attributed to System 620A. Pacific range officials lowered the requirement to three new ships and modification of an existing vessel, totalling \$69 million. By the middle of May, Navy officials agreed that ship costs of \$36 million and a total range requirement of \$49 million were directly related to the Dyna-Soar program. Because of subsequent revisions to the program, range officials then submitted an increased estimate of \$69 million for both the October 10, 1962 and the January 11, 1963 system package programs. The Dyna-Soar office did not concur with this figure, however, total range costs relating to System 620A were agreeably reduced to \$48.888 million in May 1963.<sup>43</sup>

resistant ability of certain sections of the glider was contemplated. Refinement of the glider design and dynamic analysis of the air vehicle vibration were additional tasks. The program office further scheduled additional testing of the reaction control, the environmental control, and the guidance systems. A more comprehensive reliability program for the glider and the communication and tracking systems was to be inaugurated, and an analysis of a means to reduce the weight of the glider subsystems was to take place.

For the Dyna-Soar office, multiorbital missions were a logical and relatively inexpensive addition to the basic program and would probably be scheduled for the fifth or sixth ground-launch. Such a demonstration, in the opinion of the Dyna-Soar office, was a prerequisite to more extensive exploration of the military function in piloted space flight. Multiorbital missions, however, necessitated modification of the guidance system, increased reliability of all subsystems, and the addition of a de-orbiting unit.

Previously, a single-orbit Dyna-Soar mission did not require the employment of a de-orbiting system, largely because the flight profile was only an around-the-world, ballistic trajectory. The Dyna-Soar office considered two alternatives for equipping the glider with a de-orbiting ability. One possibility was to place a system in the transition section of the glider. Another approach, actually chosen, was to employ the transtage of the Titan IIIC vehicle. This fourth stage would permit accurate orbital injection of the glider and would remain attached to the transition section to provide de-orbiting propulsion.

Along with these additions to the system package program, the Dyna-Soar office submitted a new funding schedule. The requirement was \$152.6 million for fiscal year 1963, \$145.2 million for 1964,



\$113.7 million for 1965, \$78.3 million for 1966, and \$17.7 million for 1967. This proposal would set the total cost for the Dyna-Soar program at \$682.1 million.<sup>45</sup>

Before the Department of Defense acted on these revisions, the system office and Air Force headquarters had to determine a new designation for Dyna-Soar, more accurately reflecting the experimental nature of the program. In his February memorandum, Secretary of Defense McNamara directed Secretary Zuckert to replace the name "Dyna-Soar" with a numerical designation, such as the X-19. Mr. J. B. Trenholm, Jr., assistant director of the program office, requested his director for program control to derive a new nomenclature for Dyna-Soar. The assistant director added that the program office should officially request retention of "Dyna-Soar" as the popular name. Whatever the designation, Air Force headquarters required it by April.<sup>46</sup>

Following Air Force regulations, the director for program control reluctantly submitted ARDC form 81A, offering the designation, XJN-1 and, at the same time, requested use of "Dyna-Soar." Colonel Ferer at USAF headquarters did not concur with the XJN-1 label but offered instead XMS-1, designating experimental-manned-spacecraft. Other elements in Air Force headquarters and in the Department of Defense objected to both designations. Finally, on June 19, 1962, USAF headquarters derived and approved the designation, X-20.<sup>47</sup> On June 26, a Department of Defense news release explained that this new designation described the experimental character of the program.<sup>48</sup> By the middle of July, Air Force headquarters allowed the word, "Dyna-Soar," to stand with X-20.<sup>49</sup>

On July 13, 1962, USAF headquarters informed the systems command that the Secretary of Defense conditionally approved the May 14 revision of the system package program. Instead of the

requested \$152.6 million for fiscal year 1963, Secretary McNamara authorized \$135 million and insisted that future funding would not exceed this level. He further stipulated that Dyna-Soar schedules would have to be compatible with Titan IIIC milestones and that technical confidence and data acquisition in the X-20 program would have precedence over flight schedules. Air Force headquarters then directed the program office to make appropriate changes to the system package as soon as possible.<sup>50</sup>

In spite of the fact that the Dyna-Soar program had been redirected, funds and approval were still lacking for System 624A, Titan III. Since the X-20 was scheduled to ride the fourth development shot of Titan IIIC, flight dates for Dyna-Soar could not be set until the Titan schedule was determined. On August 31, 1962, the space division informed the X-20 office that calendar dates for booster launchings could not be furnished until funding had been released. This was expected by November, with program development beginning in December 1962. The first Titan IIIC launch would occur 29 months later, and the fourth shot (the first, Dyna-Soar, unmanned launch) would take place 36 months after program "go-ahead."<sup>51</sup>

Based on this Titan IIIC scheduling assumption, the X-20 system office completed, on October 10, another system package program. Twenty air-drop tests were to be conducted from January through October 1965. Two unmanned orbital launches were to occur in November 1965 and February 1966. The first of eight piloted flights was to take place in May 1966, with a possible multiorbit launch occurring in November 1967.\* The Dyna-Soar office stipulated that \$135 million would be required in fiscal year 1963,

---

\*These X-20 schedules proved compatible with the Titan III schedules, for on October 15, 1962, Air Force headquarters issued System Program Directive 9. This authorized research and development of the space booster to begin on December 1, 1962 with a total of \$745.5 million from fiscal year 1962 through 1966.

\$135 million in 1964, \$102.78 million in 1965, \$107.51 million in 1966, \$66.74 million in 1967, and \$10 million in 1968. The program would require \$766.23 million for the development of the orbital X-20 vehicle.<sup>52</sup> Major General R. G. Ruegg, ASD commander, submitted this system package program to AFSC headquarters on October 12, 1962, however, it never received command endorsement.

While the X-20 office was concerned with Titan III schedules and approval of a new package program, AFSC headquarters directed a change in the organization of ASD which had possible significance for the Dyna-Soar program. On September 28, 1962, the systems command directed that the function of the ASD Field Test Office at Patrick Air Force Base, Florida, be transferred to the 6555th Aerospace Test Wing of the Ballistic Systems Division.<sup>53</sup>

Previously ARDC headquarters had established, on August 4, 1960, a general policy on test procedures which firmly placed control of system testing in the various project offices rather than the test centers.<sup>54</sup> With headquarters' approval, the Dyna-Soar office appointed a test director for the entire Category II program and directed that the Air Force Flight Test Center provide a Deputy Director for Air-Launch and the WADD Field Test Office at Patrick Air Force Base provide a Deputy Director for Ground-Launch.<sup>55</sup> The test centers, however, objected to giving the project offices full authority, largely because such a policy did not fully utilize their ability to conduct flight test programs. Consequently, on January 31, 1962, General Schriever rescinded the August 1960 policy and directed that, while overall authority still rested in the program offices, the centers and test wings would prepare and implement the test plans and appoint local test directors.<sup>56</sup> While the purpose of this new policy was to give the test centers more authority in the test program, it did not result

in any significant changes to the structure of the Dyna-Soar test force. Under this new arrangement, the program office appointed a Deputy System Program Director for Test, while the flight test center provided the Air-Launch Test Force Director and the Patrick field office, the Ground-Launch Test Force Director.<sup>57</sup>

Throughout these changes in the Dyna-Soar test structure, the 6555th Aerospace Test Wing of the Ballistic Systems Division had authority only during the operation of the booster. With the transfer of the functions of the ASD field office to this test group, however, the aerospace wing became, in effect, the director of the orbital flight tests. This test group was responsible to the commander of BSD, who, in the instance of conflicting requirements of various assignments, would determine priorities for the operations of his test wing.<sup>58</sup>

In an effort to conserve program funds, the X-20 office formulated a flight test program, the "Westward-Ho" proposal, which would eliminate the necessity for the construction of several control centers and multiple flight simulators. Previous planning had located a flight control center at Edwards Air Force Base for the conduct of the air-launch tests. The ground-launch program required a launch center and a flight control center, both at Cape Canaveral, and also a recovery center at Edwards Air Force Base. "Westward-Ho" simply proposed the consolidation of the flight control centers for both the air-drop and ground-launch tests at Edwards, leaving only a launch control center at the Cape. The Air Force Flight Test Center would provide a test director for both the air-drop and orbital flight tests, who would be responsible in turn to the X-20 program office. By establishing one flight control center and employing only one flight simulator, the Dyna-Soar office estimated a savings of at least \$3 million.<sup>59</sup>

The "Westward-Ho" logic of the X-20 office was not apparent to AFSC headquarters. On December 19, the AFSC vice commander,

Lieutenant General Estes, directed the establishment of a manned space flight review group for the purpose of examining all aspects of the X-20 test program including the relationships of the various AFSC agencies. Brigadier General O. J. Glasser of the Electronic Systems Division was named chairman of this group, which was to be composed of representatives from AFSC headquarters, the aeronautical division, the space division, the missile test center and the missile development center.<sup>60</sup>

Colonel Moore noted that the Air Force Flight Test Center, the key agency in "Westward-Ho" had not been permitted representation at this review. Furthermore, he had offered to familiarize the committee with a presentation on the Dyna-Soar test requirement, but this proposal was rejected.<sup>61</sup> The significance of the coming review was not entirely clear to the X-20 program office.

General Glasser's committee formally convened on January 3 and 23 and February 5, 1963. While no decisions were made at these meetings, the members discussed several critical points of the Dyna-Soar program. Although the Test Support Panel seemed to favor the location of a single flight control center at Edwards Air Force Base, it was clear that "Westward-Ho" impinged on the interests of the Air Force Missile Development Center, the Space Systems Division, and the Air Force Missile Test Center. General Glasser, however, emphasized the central problem confronting the Dyna-Soar program: the open conflict between the Space Systems Division and the Aeronautical Systems Division for control of the only Air Force manned space program. The Organization and Management Panel offered some solutions to this problem. First, management of the program by AFSC headquarters would have to be altered. Like the Titan III program, the Dyna-Soar system should be placed under the guidance of the Deputy to the Commander for Manned Space Flight instead of the Deputy Chief of Staff for Systems. More important, the panel strongly recommended that the entire program be

reassigned to the Space Systems Division. General Glasser did not favor such a radical solution but thought that a single AFSC division should be made the arbiter for both the Titan III and X-20 programs.<sup>62</sup>

While designating his deputy for manned space flight as a headquarters point of contact for the Dyna-Soar program, General Schriever, on May 9, 1963, altered the structure of the X-20's test force. He directed that the Space Systems Division would name the director for X-20's orbital flights, with the flight control center being located at the Satellite Test Center, Sunnyvale, California. The commander of AFSC did emphasize, however, that the Aeronautical Systems Division was responsible for the development of the X-20.<sup>63</sup> At the end of July, General Schriever also assigned responsibility for the air-launch program and pilot training to the space division.<sup>64</sup>

Although the Air Force had undertaken a manned military space study in 1961, the Department of Defense still had not determined a military space mission for the Air Force. While the 1961 study had essentially compared the Dyna-Soar glider with a SAINT II lifting body, Secretary McNamara was also interested in the military potentialities of the two-man Gemini capsule of NASA. In his February 23, 1962 memorandum, the Secretary of Defense expressed interest in participating in this program with the National Aeronautics and Space Administration for the purpose of demonstrating manned rendezvous.<sup>65</sup> On January 18 and 19, 1963, Secretary McNamara directed that a comparison study between the X-20 glider and the Gemini vehicle be made which would determine the more feasible approach to a military capability. He also asked for an evaluation of the Titan III and various alternative launch vehicles.<sup>66</sup>

A few days later, Gemini became even more significant to the Air Force, for the Department of Defense completed an agreement

with the National Aeronautics and Space Administration which permitted Air Force participation in the program. A planning board, chaired by the Assistant Secretary of the Air Force for Research and Development and the Associate Administrator of NASA, was to be established for the purpose of setting the requirements of the program. The agreement stipulated that the Department of Defense would not only participate in the program but would also financially assist in the attainment of Gemini objectives.<sup>67</sup>

At the end of January, Major General O. J. Ritland, Deputy to the Commander for Manned Space Flight, emphasized to the commanders of ASD and SSD that Secretary McNamara intended to focus on the X-20, Gemini, and Titan III programs with the ultimate objective of developing a manned military space system. General Ritland warned that once a decision was made it would be difficult for the Air Force to alter it. Consequently, command headquarters, the space division, and the aeronautical division would have to prepare a comprehensive response to the secretary's request. General Ritland then gave the Space Systems Division the responsibility for providing statements of the Air Force manned space mission and for defining space system requirements, tests, and operations.<sup>68</sup>

By the end of February 1963, AFSC headquarters had compiled a position paper on the X-20 program. Six alternative programs were considered: maintain the present program, reorient to a lower budget through fiscal year 1964, accelerate the flight test program, reinstate a suborbital phase, expand the program further exploring technological and military objectives, and, finally, terminate the X-20 program. The conclusion of command headquarters was to continue the present X-20 and Titan III programs.<sup>69</sup>

Early in March General LeMay offered his thoughts on the coming review by the Secretary of the Air Force. He firmly stated that continuation of Titan III was absolutely necessary, and most

important, the current X-20 program should definitely proceed. The Air Force Chief of Staff emphasized that the Dyna-Soar vehicle would provide major extensions to areas of technology important to the development of future military systems and, consequently, the Air Force should not consider termination of the X-20 program or delay of schedules for the approval of an alternative space program. General LeMay insisted that the purpose of Air Force participation in the Gemini program was limited to obtaining experience and information concerning manned space flight. The Chief of Staff underlined that the interest of the Air Force in the NASA program was strictly on the basis of an effort in addition to the Dyna-Soar program.<sup>70</sup>

After hearing presentations of the X-20, Gemini, and Titan III programs in the middle of March, Secretary McNamara reached several conclusions which seemed to reverse his previous position on the experimental nature of the Dyna-Soar program. He stated that the Air Force had been placing too much emphasis on controlled reentry when it did not have any real objectives for orbital flight. Rather, the sequence should be the missions which could be performed in orbit, the methods to accomplish them, and only then the most feasible approach to reentry. Dr. Brown, however, pointed out that the Air Force could not detail orbital missions unless it could perform controlled reentry. Furthermore, the Director of Defense for Research and Engineering stated that the widest lateral mobility, such as possessed by the X-20, during landing was necessary in performing military missions. Dr. McMillan surmised that Secretary McNamara did not favor immediate termination of the X-20 program.<sup>71</sup> Secretary McNamara did request, however, further comparison between Dyna-Soar and Gemini in the light of four military missions: satellite inspection, satellite defense, reconnaissance in space, and the orbiting of offensive weapon systems.<sup>72</sup>



On May 10, 1963, a committee composed of officials from the aeronautical and space divisions completed their response to Secretary McNamara's direction. The committee was aware that the Dyna-Soar glider had sufficient payload capacity for testing a large number of military components and that the X-20's demonstration of flexible reentry would be an important result of the flight test program. Concerning Gemini, the committee also recognized that this program would enhance knowledge relating to maneuverability during orbit and consequently recommended the incorporation of a series of experiments leading to the testing of military subsystems. Further in the future both vehicles could be adapted to serve as test craft for military subsystems; however, neither could, without modification, become a fully qualified weapon system for any of the missions specified by Secretary McNamara. With the employment of Titan III instead of Titan II and the incorporation of a mission module, this Gemini system could provide greater orbital maneuverability and payload capacity than the X-20. The Dyna-Soar vehicle, however, would provide greater flexibility during reentry and, unlike Gemini, could return the military subsystems to Earth for examination and reuse.<sup>73</sup>

General Ritland forwarded this report to Air Force headquarters a few days later. The deputy for manned space flight recommended that the X-20 program be continued because of the contribution that a high lift-to-drag ratio reentry vehicle could make for possible military missions. Air Force participation in the Gemini program, however, should be confined to establishing a small field office at the NASA Manned Space Center and seeing that military experiments were part of the program.<sup>74</sup>

While the Department of Defense had not made a final determination concerning the X-20 and Gemini, General Estes cautioned the Dyna-Soar office at the end of June that the

Secretary of Defense was still studying the military potential of both approaches. The vice commander stated that the system office had to maintain a position which would permit continuation of the program while at the same time restricting contractor actions to assure minimum liability in event of cancellation.<sup>75</sup>

While the X-20 and Gemini approaches to orbital flight were under examination, the Dyna-Soar office was also confronted with an adjustment to the program because of a pending budget reduction. In November 1962, it had been apparent that the Department of Defense was considering restriction of fiscal year 1963 and 1964 funds to \$130 million and \$125 million instead of the previously stipulated level of \$135 million for both years.<sup>76</sup> Colonel Moore pointed out to AFSC headquarters that only through aggressive efforts would \$135 million be sufficient for fiscal year 1963 and any proposed reduction would be based on a lack of understanding of the Dyna-Soar requirements. Furthermore, an increase in fiscal year 1964 funds was necessary, raising the figure to \$147.652 million.<sup>77</sup> Later, the system office informed General LeMay that schedules could not be maintained if funding were reduced and that \$135 million and \$145 million would be required for fiscal years 1963 and 1964.<sup>78</sup>

During March 1963, the X-20 office prepared four funding alternatives, which General Estes submitted to Air Force headquarters at the end of the month. The most desirable approach was to maintain the program schedules as offered in the October 10, 1962 system package program by increasing the funding. The X-20 office estimated that \$135 million was required for fiscal year 1963, \$145 million for 1964, and \$114 million for 1965, which gave a total program cost of \$795 million. The second alternative was to authorize a ceiling of \$792 million, with \$135 million allotted for 1963, \$135 million for 1964, and \$120 million for 1965. This reduction could be accomplished by deferring the

multiorbit flight date by six months. The third option required \$130 million for 1963, \$135 million for 1964, and \$130 million for 1965, with a program total of \$807 million. Such a funding arrangement would delay the entire program by two months and defer the multiorbit flight from the fifth to the seventh ground-launch. The least desirable approach was to delay the entire program by six months, authorizing \$130 million for 1963, \$125 million for 1964, and \$125 million for 1965. Under this alternative, the program would total \$828 million.<sup>79</sup>

On April 12, 1963, Air Force headquarters accepted the third alternative. A funding level of \$130 million was established for 1963 and the system office was directed to plan for \$135 million in 1964. Headquarters stipulated that program schedules could not be delayed by more than two months and that a new system package program had to be submitted by May 20.<sup>80</sup>

On January 15, 1963, the Dyna-Soar office had completed a tentative package program which included the same funding and flight schedules as the October 10, 1962 proposal. The central difference was that the latter program incorporated the "Westward-Ho" proposal.<sup>81</sup> This system package program, however, was not submitted to AFSC headquarters for approval. In accordance with the April 12, 1963 instruction, the X-20 office completed another system package program on May 6 which was distributed to the various program participants for their comments. On May 9, however, General Schriever assigned the orbital test responsibility to the Space Systems Division, and, consequently, AFSC headquarters again instructed the Dyna-Soar office to revise the X-20's system package program by May 13.<sup>82</sup>

In the May 13 system package program, the X-20 office estimated that \$130 million was required for fiscal year 1963, \$135 million for 1964, \$130 million for 1965, \$110 million for 1966, and

\$73 million for 1967. The air-launch program was to extend from March 1965 through January 1966, with the two unmanned ground-launches occurring in January and April 1966. The first piloted flight would take place in July 1966 with the first multiorbit flight occurring in May 1967. The eighth and final piloted flight was to be conducted in November 1967.<sup>83</sup> Brigadier General D. M. Jones, acting commander of ASD, informed AFSC headquarters that there had been insufficient time to incorporate the details of the new test organization in the program package. Furthermore, a funding level of \$130 million and \$135 million for fiscal years 1963 and 1964 could delay Dyna-Soar flights by more than the two months anticipated in the April 12 direction of USAF headquarters.<sup>84</sup>

On May 27, another system package program was completed. The same funding rates as the May 13 proposal were retained but the flight schedule was revised in order to conform with firm contractor estimates. The air-launch program was to extend from May 1965 through May 1966. The two unmanned launches were to take place in January and April 1966, and the first piloted launch was to occur in July 1966. Recognizing the necessity for a four month interval between single and multiorbit flights, the X-20 office set August instead of May 1967 for the first multiorbit launch. The Dyna-Soar flight test program was to terminate in February 1968 with the eighth orbital launch.<sup>85</sup>

The Secretary of the Air Force gave his approval to this system package program on June 8, 1963; however, the Department of Defense did not accept the recommended funding. On July 3, AFSC headquarters informed the Dyna-Soar office that attempts to secure additional funding had failed. The funding level for fiscal year 1964 was \$125 million.<sup>86</sup> By September it was clear to the Dyna-Soar office that the consequence of this reduced funding level would be to delay multiorbital flight from the seventh to the ninth ground-launch.<sup>87</sup>

While final approval by the Department of Defense of the Dyna-Soar system package was still pending in the middle of 1963, the impact of the December 1961 redirection on the Dyna-Soar program was apparent. The first Dyna-Soar development plan of October 1957 had definite military objectives leading to the development of orbital reconnaissance and bombardment vehicles. In April 1959, Dr. York, then Director of Defense for Research and Engineering, altered these goals and placed major emphasis on the development of a suborbital research vehicle. In spite of intensive comparative studies with manned SAINT and Gemini vehicles, the central purpose, as established by Dr. York, had not changed. While the system program directive of December 1961 and Secretary McNamara's memorandum of February 1962 elevated Dyna-Soar to an orbital vehicle, the glider was officially described as an experimental system.

Conceivably the redirected program could appear as a reversal of the three-step approach which was aimed at the development of a suborbital system, an orbital glider with interim military ability, and an operational weapon system. Yet, under this old development plan, the real Dyna-Soar program had only consisted of a glider which would perform suborbital flight. Consequently, Department of Defense sanction of the new program marked an advancement over the three-step approach in that orbital and even multiorbital flights of the X-20 glider were now established objectives of Dyna-Soar.

## NOTES

1. Ltr., Brig. Gen. M. B. Adams, Dep. Dir., Sys. Dev., Hqs. USAF to Cmdr., ARDC, Oct. 12, 1960, subj.: Development Directive No. 411.
2. Ltr., Col. W. L. Moore, Jr., Dir., Dyna-Soar SPO, ASD, to Cmdr., ARDC, Feb. 23, 1961, subj: Preliminary Results of Dyna-Soar "Stand-by" Program Study.
3. Ibid.; TWX, AFSDS-AS-81749, Hqs. USAF to Hqs. ARDC, Jan. 31, 1961; System Package Program, System 620A, Dyna-Soar SPO, ASD, Apr. 26, 1961, pp. 411, 487A.
4. Memo., Col. W. L. Moore, Jr., Dir., Dyna-Soar SPO, ASD, Mar. 20, 1961, subj.: "Stand-by" Program.
5. Presn., Boeing Co. to Dyna-Soar SPO, ASD, May 4, 1961, subj.: Project Streamline, pp. 1, 29.
6. Rpt., Dyna-Soar SPO, ASD, Sept. 1, 1961, subj.: Dyna-Soar Program Description; System Package Program, System 620A, Dyna-Soar SPO, ASD, June 26, 1961, pp. 395-399.
7. Proposed Development Plan for an Advanced Reentry Technology Program, Hqs. SSD, May 29, 1961, p. 1-5.
8. System Package Program, Expanded SAINT Program, Hqs. SSD; May 29, 1961, pp. 1-1 to 1-8, V-63, VII-2.
9. Ltr., Col. W. L. Moore, Jr., Dir., Dyna-Soar SPO to Brig. Gen. A. T. Culbertson, Dir., Sys. Mangt., ASD, June 28, 1961, subj.: Dyna-Soar, SSD Advanced Reentry Technology Program and SAINT II Proposed Conflict.
10. Minutes, Capt. J. W. Launderville, Dyna-Soar Dir., SSD, May 12, 1961, subj.: The Ninth Meeting of the Technical Evaluation Board.
11. TWX, SSVS-10-7-3, Hqs. SSD to Hqs. ASD, July 11, 1961.
12. Presn., Col. W. L. Moore, Jr., Dir., Dyna-Soar SPO, to Strategic Air Panel, Hqs. USAF, Aug. 3, 1961, subj.: Project Streamline.
13. Ibid.
14. Memo., Brockway McMillan, ASAF/Res. & Dev., Aug. 18, 1961, subj.: Standardized Space Booster Program, in the files of the Dyna-Soar Sys. Staff Ofc., DCS/Sys. & Log., Hqs. USAF.

15. Ltr., Gen. B. A. Schriever, Cmdr., AFSC to Gen. C. E. LeMay, CS/AF, Aug. 1, 1961, subj.: Acceleration of Dyna-Soar Program, in the files of the Dyna-Soar Sys. Staff Ofc., DCS/Sys. & Log., Hqs. USAF.
16. TWX, SCGV-11-8-18, Hqs. AFSC to DCAS, Hqs. AFSC, Aug. 11, 1961.
17. Memo., Lt. Gen. R. C. Wilson, DCS/Dev., Hqs. USAF to CS/AF, Apr. 11, 1961, subj.: Dyna-Soar Management, in files of Dyna-Soar Sys. Staff Ofc., DCS/Sys. & Log., Hqs. USAF; ltr., Gen. C. E. LeMay, VCS/AF to SAF, May 5, 1961, subj.: Dyna-Soar Program, in files of Dyna-Soar Sys. Staff Ofc.; memo., J. V. Charyk, SAFUS to CS/AF, subj.: Dyna-Soar Program, in files of Dyna-Soar Sys. Staff Ofc.; memo., SAF, July 25, 1961, subj.: Designated Management Group; memo., Maj. Gen. R. M. Montgomery, Asst. VCS/AF, Aug. 1, 1961, subj.: Designated Systems Management Group and Systems Review Board.
18. Ltr., Col. T. H. Runyon, Ec. Secy., DSMG, Hqs. USAF to DCS/Sys. & Log., Hqs. USAF, Sept. 5, 1961, subj.: DSMG Meeting on Dyna-Soar, in files of the Dyna-Soar Sys. Staff Ofc., DCS/Sys. & Log., Hqs. USAF.
19. Ltr., Lt. Gen. H. M. Estes, Jr., DCAS, Hqs. AFSC to Gen. B. A. Schriever, Cmdr., AFSC, Sept. 28, 1961.
20. Ltr., Ad Hoc Committee, SAB to Gen. B. A. Schriever, Cmdr., AFSC, Sept. 28, 1961; rpt., SAB, Dec. 12, 1961, subj.: A Report on Operations During 1961, p. 15.
21. Ltr., Lt. Gen. Estes to Gen. Schriever, Sept. 28, 1961.
22. Memo., SAFUS to CS/AF, Sept. 28, 1961, subj.: West Coast Trip by Secretary McNamara.
23. TWX, AFSDC-67166, Hqs. USAF to Hqs. AFSC, Oct. 3, 1961.
24. TWX, AFSDC-S-67777, Hqs. USAF to Hqs. AFSC, Oct. 5, 1961.
25. Abbreviated Development Plan, System 620A, Dyna-Soar SPO, ASD, Oct. 7, 1961, subj.: Manned, Military, Space Capability, pp. 1-2, 6-7, 17-25, 41-42, fig. 2.
26. Trip rpt., W. E. Lamar, Dep. Dir/Dev., Dyna-Soar SPO to Col. W. L. Moore, Jr., Dir., Dyna-Soar SPO, ASD, Oct. 18, 1961, subj.: Briefing to Military, Manned, Spacecraft, Study Panel on Dyna-Soar; trip rpt., Lamar to Maj. Gen. W. A. Davis, Cmdr., ASD, Nov. 1, 1961, subj.: Briefing to Dr. Kavanau, DDR&E, Oct. 25, 1961.
27. Interview, W. M. Lyon, Asst. Ch., Ops. Div., Dyna-Soar SPO, by C. J. Geiger, Hist. Div., ASD, Oct. 6, 1961.

28. Memo., Dep., DDR&E, DOD to ASAF/Res. & Dev., Oct. 13, 1961, subj.: Titan III Launch Vehicle Family.
29. Development Plan, Dyna-Soar, DCAS, Hqs. AFSC, Nov. 16, 1961, pp. 7-21, 44-52.
30. TWX, AFSDC-85-081, Hqs. USAF to Hqs. AFSC, Dec. 11, 1961.
31. Ltr., Col. Floyd Finberg, Asst. Dep. Dir/Prog. Control, Dyna-Soar SPO, to W. E. Lamar, Dep. Dir/Dev., Dyna-Soar SPO, ASD, Dec. 12, 1961, subj.: Redirected Program; memo., Col. W. L. Moore, Jr., Dir., Dyna-Soar SPO, ASD, Dec. 15, 1961, subj.: Program Redirection.
32. Memo., Col. J. E. Christensen, Dep. Dir/Proc. & Prod., Dyna-Soar SPO, ASD, Dec. 15, 1961, subj.: Program Reorientation, Bulletin No. 10.
33. SPD 4, DCS/Sys. & Log., Hqs. USAF, Dec. 27, 1961.
34. TWX, ASG-27-12-9, Maj. Gen. W. A. Davis, Cmdr., ASD to Hqs. AFSC, Dec. 27, 1961; amend. 1 to SPD 4, DCS/Sys. & Log., Hqs. USAF, Feb. 2, 1962.
35. Amend. 1 to ADO 19, DCS/Res. & Tech., Hqs. USAF, Feb. 21, 1962.
36. Memo., Secy. of Def. to SAF, Feb. 23, 1962, subj.: The Air Force, Manned, Military, Space Program.
37. Daily Activity Rpt., Dyna-Soar SPO, ASD, Mar. 19, 1962; Program Summary, System 620A, Dyna-Soar SPO, May 14, 1962, pp. 2-3.
38. Daily Activity Rpt., Dyna-Soar SPO, ASD, Apr. 19, 1962; ltr., Maj. Gen. W. A. Davis, Cmdr., ASD to Maj. Gen. M. F. Cooper, DCS/Sys., Hqs. AFSC, Apr. 25, 1962, subj.: System 620A Package Program.
39. TWX, AFSDC-S-93823, Hqs. USAF to Hqs. AFSC, June 5, 1962; TWX, ASZR-17-7-1014, Hqs. ASD to Hqs. AFSC, June 18, 1962; TWX, LSCSAD-23-7-18, Hqs. AFSC to Hqs. ASD, July 25, 1962.
40. Proposed System Package Plan, System 624A, Hqs. SSD, Apr. 30, 1962, Vol. I, p. 1-2.
41. System Package Program, System 620A, Dyna-Soar SPO, ASD, May 14, 1962, pp. 1-1, 2-21, 5-3, 5-5, 6-10.
42. Ltr., Maj. Gen. W. A. Davis, Cmdr., ASD to Maj. Gen. M. F. Cooper, DCS/Sys., Hqs. AFSC, Apr. 25, 1962, subj.: System 620A Package.



43. Ibid.; System Package Program, System 620A, Dyna-Soar SPO, ASD, Apr. 26, 1962, p. 11-13; System Package Program, System 620A, May 14, 1962, p. 11-14; System Package Program, System 620A, Oct. 11, 1962, p. 11-15; System Package Program, System 620A, Jan. 11, 1963, p. 11-15; System Package Program, System 620A, May 13, 1963, p. 11-7.
44. Interview, W. M. Lyon, Asst. Ch., Ops. Div., Dyna-Soar SPO, ASD by C. J. Geiger, Hist. Div., ASD, Oct. 6, 1962.
45. System Package Program, System 620A, Dyna-Soar SPO, ASD, May 14, 1962 pp. 6-1, 6-54, 6-55, fig. 1-1.
46. Ltr., J. B. Trenholm, Jr., Asst. Dir., Dyna-Soar SPO, to Dep. Dir/Prog. Control, Dyna-Soar SPO, ASD, Mar. 20, 1962, subj.: Item for Action.
47. Interview, R. C. Johnston, Ch., Ops. Div., Dyna-Soar SPO, ASD by C. J. Geiger, Hist. Div., ASD, Oct. 12, 1962.
48. DOD News Release, June 26, 1962, subj.: Dyna-Soar Designated X-20 by the Air Force.
49. Memo., Maj. J. C. Buckner, Ops. Div., Dyna-Soar SPO, ASD, July 17, 1962, subj.: X-20 Designation for Dyna-Soar.
50. TWX, AFSDC-5-9-65922, Hqs. USAF to Hqs. AFSC, July 13, 1962.
51. TWX, SSBT-31-8-26, Hqs. SSD to Hqs. ASD, Aug. 31, 1962.
52. System Package Program, System 620A, Dyna-Soar SPO, ASD, Oct. 10, 1962, pp. 2-6, 11-5.
53. TWX, ASFP-5-10-1, ASD Fld. Test Ofc. to Hqs. ASD, Oct. 5, 1962.
54. Ltr., Maj. Gen. M. F. Cooper, DCS/Res. & Engg., Hqs. ARDC to Hqs. WADD, Aug. 15, 1950.
55. TWX, RDRA-30-9-43, Hqs. ARDC to Hqs. WADD, Sept. 30, 1960.
56. Interview, Lt. Col. C. Svimonoff, Dep. Sys. Prog. Dir/Test, Dyna-Soar SPO, ASD by C. J. Geiger, Hist. Div., ASD, Apr. 30, 1963; memo., Gen. B. A. Schriever, Cmdr., AFSC, Jan. 31, 1962, subj.: AFSC System Test Policy Procedures.
57. System Package Program, System 620A, Dyna-Soar SPO, ASD, May 14, 1962, pp. 5-15, 5-19.
58. Memo., Maj. Gen. W. A. Davis, Cmdr., BSD and Maj. R. G. Ruegg, Cmdr., ASD, Oct. 16, 1962, subj.: Support of Test Programs by the 6555 ATW, Patrick AFB, Florida.

59. Rpt., Dyna-Soar SPO, ASD Oct. 26, 1962, subj.: A Reexamination of the X-20 Test Operation concept, pp. 2, 4, 11-12, 16, 26.
60. TWX, SCSS-19-21-1, Hqs. AFSC to Hqs. ASD, Dec. 19, 1962.
61. Ltr., Col. W. L. Moore, Jr., Dir., Dyna-Soar SPO, ASD to Maj. Gen. R. G. Ruegg, Cmdr., ASD, Jan. 2, 1963, subj.: Manned Space Flight Review Group.
62. Minutes (unofficial), Dyna-Soar SPO, ASD, Jan. 3 and 23, 1963, Feb. 5, 1963, subj.: Manned Space Flight Review Group.
63. Ltr., Gen. B. A. Schriever, Cmdr., AFSC to Cmdr. SSD, May 9, 1963, subj.: X-20 Program Management.
64. Ltr., Gen. Schriever to Cmdr. ASD, July 31, 1963, subj.: X-20 Program.
65. Memo., Secy. of Def. to SAF, Feb. 23, 1962, subj.: The Air Force, Manned, Military, Space Program.
66. Memo., Secy. of Def. to DDR&E, DOD, Jan. 18, 1963; memo., Secy. of Def. to DDR&E, Jan. 19, 1963; memo., Secy. of Def. to DDR&E, Jan. 19, 1963.
67. Memo., J. E. Webb, Administrator, NASA and R. S. McNamara, Secy. of Def., Jan. 21, 1963, subj.: Agreement Between the National Aeronautics and Space Administration and the Department of Defense Concerning the Gemini Program.
68. Ltr., Maj. Gen. O. J. Ritland, Dep. to Cmdr/Manned Space Flight, Hqs. AFSC to Cmdr., SSD, Jan. 31, 1963, subj.: Gemini-Dyna-Soar Task Groups.
69. Rpt., Hqs. AFSC, Feb. 26, 1963, subj.: The X-20 Program.
70. Ltr., Gen. C. E. LeMay, CS/AF to SAF, Mar. 2, 1963, subj.: DOD Review of USAF Space Program.
71. Memo., Brockway McMillan, ASAF/Res. & Dev. to SAF, Mar. 15, 1963.
72. Memo., Secy. of Def. to SAF, Mar. 15, 1963.
73. Rpt., Dep/Tech., SSD, May 10, 1963, subj.: Response to Secretary McNamara's Mar. 15, 1963 Questions, I, viii-xiii.
74. Ltr., Maj. Gen. O. J. Ritland, Dep. to Cmdr/Manned Space Flight, Hqs. AFSC to Hqs. USAF, May 22, 1963, subj.: Response to Secretary McNamara's Mar. 15, 1963 Questions.

75. Lt. Gen. H. M. Estes, Jr., Vice Cmdr., AFSC to Maj. Gen. R. G. Ruegg, Cmdr., ASD, June 21, 1963, subj.: X-20 Program Guidance for FY 1964.
76. Ltr., Maj. Gen. M. F. Cooper, DCS/Sys., Hqs. AFSC to Lt. Gen. H. M. Estes, Jr., Vice Cmdr., AFSC, Nov. 16, 1962, subj.: X-20 (Dyna-Soar) System Package Program.
77. Ltr., Col. W. L. Moore, Jr., Dir., Dyna-Soar SPO to Hqs. AFSC, Dec. 13, 1962, subj.: Redline Presto Follow-on Information; ltr., Col. Moore to Hqs. AFSC, Dec. 26, 1962, subj.: Redline Presto Follow-on Information.
78. TWX, AFRAE-69512, CSAF to Hqs. AFSC, Jan. 18, 1963; TWX, SCSAS-28-1-59, Hqs. AFSC to CSAF, Jan. 28, 1963.
79. Lt. Gen. H. M. Estes, Jr., Vice Cmdr., AFSC to Hqs. USAF, Mar. 30, 1963, subj.: X-20 Program.
80. TWX, AFRDC-92965, Hqs. USAF to Hqs. AFSC, Apr. 12, 1963.
81. Tentative System Package Program, System 620A, Dyna-Soar SPO, Jan. 15, 1963, pp. 2-27, 11-5.
82. TWX, MSFA-9-5-17, Hqs. AFSC to Hqs. ASD, May 9, 1963.
83. System Package Program, System 620A, Dyna-Soar SPO, May 13, 1963, p. 1-5.
84. Ltr., Brig. Gen. D. M. Jones, Acting Cmdr., ASD to Hqs. AFSC, May 13, 1963, subj.: Revised X-20A System Package Program.
85. System Package Program, System 620A, Dyna-Soar SPO, May 27, 1963, p. 1-5.
86. TWX, AFRDDG-68949, Hqs. USAF to Hqs. AFSC, June 10, 1963; TWX, SCCP3-7-2, Hqs. AFSC to Hqs. ASD, July 3, 1963.
87. System Package Program, System 620A, Dyna-Soar SPO, Sept. 3, 1963, p. 1-5.



## CHAPTER V

### CANCELLATION

In 1963 the Department of Defense was again seriously questioning the necessity for the Dyna-Soar program. It appeared that the alternative for the X-20 had been severely narrowed: direct the program towards achieving military goals or terminate it in lieu of another approach to a manned military space system. During the Phase Alpha studies of 1960 and the Manned Military Space Capability Vehicle studies of 1961, the reentry approach of the Dyna-Soar glider was critically compared with other reentry proposals and systems. On these two occasions, both the Air Force and the Department of Defense deemed the Dyna-Soar as the most feasible. The X-20 program, however, was not as fortunate in the 1963 evaluations.

In December 1961, Air Force headquarters had eliminated suborbital launches of the Dyna-Soar vehicle and had directed the early attainment of orbital flight. The objectives were to obtain research data on maneuverable reentry and demonstrate conventional landing at a preselected site.<sup>1</sup> Secretary of Defense Robert S. McNamara later confirmed this redirection and identified the purposes of the military space program. He stated that the establishment of the necessary technology and experience for manned space missions were the immediate goals. The Secretary placed emphasis on acquiring the ability to rendezvous with uncooperative targets, to maneuver during orbital flight and reentry, to achieve precise recovery, and to reuse the vehicles with minimum refurbishment. In order to realize these ends, Secretary McNamara offered three programs. The orbital research Dyna-Soar program would provide a necessary technological basis. A cooperative

effort with the National Aeronautics and Space Administration in its Gemini program would give experience in manned rendezvous. Lastly the defense secretary stated that a manned space laboratory to conduct sustained tests of military systems could be useful.<sup>2</sup>

It was not until January 1963 that Secretary McNamara took another significant step in defining a military space program. He directed a comparison between the Dyna-Soar program and the Gemini program of NASA to determine which would be of more military value.<sup>3</sup> Gemini became even more important a few days later when the Department of Defense completed an agreement with the national aeronautics administration for Air Force participation. Following a review in the middle of March of the Dyna-Soar program, Secretary McNamara further clarified his directions concerning the Gemini and X-20 study. He considered that the Air Force had placed too much emphasis on controlled reentry and not on the missions which could be performed in orbit. Inspection, reconnaissance, defense of space vehicles, and the introduction of offensive weapons in space were all significant. He suggested that the Air Force take as long as six months to determine the most practicable test vehicle for these military space missions. The Secretary of Defense then suggested that a space station serviced by a ferry vehicle could be the most feasible approach.<sup>4</sup> Air Force headquarters directed the Air Force Systems Command to organize studies concerning X-20 and Gemini contributions to these four missions.<sup>5</sup>

By May 10, a committee, under the leadership of the Space Systems Division and composed of representatives from the Aerospace Corporation, Air Force Systems Command headquarters, and the Aeronautical Systems Division, completed a comparison of Gemini and the X-20. The committee considered that the current X-20 program could be rapidly, and with relative economy, adapted for testing of military subsystems and military operations. There were several reasons. The Dyna-Soar glider had a payload volume of 75 cubic

feet, sufficient power, and enough cooling capacity to accommodate subsystems required for military missions. Furthermore, the orbital duration of the vehicle could be extended to 24 hours or longer.

Concerning reconnaissance missions, the committee thought that the X-20 program could develop low, orbital, operational techniques and ground recognition ability. The research data from the program would also be applicable for the verification of the feasibility, design, and employment of glide bombs. The fact that the X-20 would develop maneuvering techniques and quick return methods made the program valuable for the development of satellite defensive missions. Since deceleration occurred slowly during lifting reentry, such an approach would provide a safe physiological environment for transfer of personnel from space stations and for other logistical missions. Lastly, significant information for the development of future maneuvering reentry spacecraft would be obtained from the X-20 program.

The committee then detailed the necessary modifications to the X-20 glider in order to allow the incorporation of either reconnaissance or satellite inspection equipment. A test program of four X-20A flights, six reorientation flights for testing reconnaissance subsystems, and two demonstration flights, would total \$206 million from fiscal years 1964 through 1968. The same type of program, this time for the testing and demonstration of inspection subsystems, would total \$228 million.<sup>6</sup>

In contrast, the technology being developed by the Gemini program of NASA related to the ability to rendezvous and orbit for long durations. The committee estimated that to incorporate a series of military experiments into the current NASA program with only minor equipment and operational flight changes would total about \$16.1 million from fiscal years 1964 through 1966. If the

Department of Defense conducted two Gemini launches and employed the same booster as NASA, the Titan II, the cost for inspection and reconnaissance experiments would total \$129 million from fiscal years 1964 through 1967. If six Department of Defense flights were conducted, the total would be \$458 million. The committee then considered a series of Gemini launches conducted by the Department of Defense, this time using the Titan IIIC. Because the 5,000 pound Gemini capsule only had a limited payload capacity of 10 cubic feet, the committee considered the addition of a mission module, which would have to be discarded in space, to the Gemini capsule. The largest test module which was considered had a volume of 700 cubic feet. The committee then examined the applicability of such a test system to reconnaissance and inspection missions. Considering a six flight program beginning in July 1966, with the following flights at five month intervals, an inspection test flight program would total \$509 million and a reconnaissance flight test program would cost \$474 million.<sup>7</sup>

The committee concluded that the main advantage of the Gemini vehicle was that it was lighter than the X-20 and consequently could carry more fuel for orbital maneuverability or have a larger payload. The inherent advantage of the X-20 was its maneuverability during reentry which meant that it could land quicker and with more landing site options. The committee recommended that a series of military experiments should be implemented in the NASA Gemini program and that additional flights of the X-20 might be warranted. Both systems could be modified to perform reconnaissance, inspection, satellite defense, and logistical missions; however, neither would directly provide a means of introducing offensive weapons into earth orbit.<sup>8</sup>

On May 22 Major General O. J. Ritland, Deputy to the Commander for Manned Space Flight, AFSC headquarters, forwarded the report to Air Force headquarters with the recommendation that the X-20



program be continued because of the contribution a high lift-to-drag ratio vehicle could make to future military systems. Air Force participation in the Gemini program should be limited to incorporating a series of military experiments into the NASA program.<sup>9\*</sup> A few weeks later, Brockway McMillan, the Assistant Secretary of the Air Force for Research and Development, summarized the report in a memorandum to the Secretary of Defense. The assistant secretary recommended that the X-20 program be energetically continued. He suggested that further examination of the military applications of the X-20 and Gemini be extended under various study programs.<sup>10</sup>

At the request of AFSC headquarters, the program office then completed a study concerning the use of the X-20 in anti-satellite missions. The Dyna-Soar office proposed an X-20B which would have an interim operational capability of satellite inspection and negation. The program office suggested that the last six flights of the current X-20A program be altered to carry inspection sensors and additional fuel for space maneuver demonstration. Two additional flights would be added to demonstrate an interim operational capability. This would necessitate a weight reduction to the X-20 glider of 700 pounds which could be achieved through a series of design changes. Such a program would total \$227 million from fiscal years 1964 through 1968. To conduct a 50 flight operational program following the completion of the two demonstration flights would cost \$1.229 billion from fiscal years 1965 through 1972.<sup>11</sup>

Near the end of June 1963, the Space Systems Division requested the X-20 office to conduct, as part of the 706 Phase 0 studies, an analysis which would show the capability of the Dyna-Soar vehicle

---

\*Secretary McNamara approved the incorporation of Air Force experiments in the NASA Gemini program on June 20, 1963.

and modified versions to fulfill satellite inspection missions.<sup>12</sup> With the assistance of the Boeing Company, the system contractor, the Minneapolis-Honeywell Regulator Company, an associate contractor, and the Air Force Aerospace Medical Division, the Dyna-Soar office completed its report by the middle of November. This study offered an inspection vehicle, the X-20X, which could have provisions for a one or two-man crew, permit orbital flight for 14 days, and be capable of inspecting targets as high as 1,000 nautical miles. The Dyna-Soar office estimated a first flight date of the X-20X in September 1967 and a probable funding requirement, depending upon the extent of modifications, ranging from \$324 million to \$364.2 million for fiscal years 1965 through 1971.<sup>13</sup>

Since the completion of the Step IIA and IIB studies by Boeing in June 1962, the Dyna-Soar office had on several occasions requested funds for intensive military application studies, and, on July 8, 1963 W. E. Lamar, Director of the X-20 Engineering Office, reiterated this request during a presentation to the Secretary of the Air Force, E. M. Zuckert.<sup>14</sup> A few days later, Secretary Zuckert, attending a meeting of the Designated Systems Management Group, directed studies of the operational applications of Dyna-Soar. He stated that the X-20 program would probably prove to be invaluable to the national military space program.<sup>15</sup>

Before the purpose of these studies was clarified, the future of the Dyna-Soar became tied to a projected space station program. On July 22 Vice President Lyndon B. Johnson raised the question of the importance of space stations to national security and requested the Secretary of Defense to prepare a statement on this subject.<sup>16</sup> Secretary McNamara replied a few days later and stressed a factor which the Air Force now had to consider: multi-manned orbital flights of long duration. The Secretary outlined some premises upon which America's manned military space program was to be based.

He stated that the investigation of the military role in space was important to national security. Because there was no clearly defined military space mission, present efforts should be directed towards the establishment of the necessary technological base and experience in the event that such missions were determined. The Secretary of Defense pointed out that Air Force participation in the Gemini program would provide much of this technological base. He considered that an orbital space station could prove useful in conducting experiments to improve capability in every type of military mission. Such a system could even evolve into an operational military vehicle. Secretary McNamara informed Vice President Johnson that he hoped to have the characteristics of an orbital space station delineated by early 1964.<sup>17</sup>

In September a subcommittee of the President's Scientific Advisory Committee Space Vehicle Panel was formed to review the available data relative to a manned orbiting station. The President's Office of Science and Technology requested the Air Force to brief the subcommittee on possible military space missions, biomedical experiments which could be performed in space, and the capability of Gemini, Apollo, and the X-20 vehicles to execute these possible future requirements.<sup>18</sup>

Additional instructions concerning the briefing to the President's Scientific Advisory Committee were relayed from the Director of Defense for Research and Engineering by Air Force headquarters to the Aeronautical Systems Division. Considerations such as modifications of the X-20 and discussion of an orbital space station should be emphasized. Air Force headquarters pointed out that the Department of Defense was not convinced that an orbital space station was needed. Rather a study of the requirements to test military equipment in space was necessary to answer questions such as equipment characteristics and the usefulness of man in space.<sup>19</sup>

A few days later Dr. Lester Lees, chairman of the subcommittee, gave additional information to Mr. Lamar about the coming presentation. Emphasis was to be on specific, meaningful experiments which the Air Force could conduct with either Gemini, Apollo, or the X-20, in order to provide a technological basis for future military space missions. Dr. Lees pointed out that it was necessary to convince a number of governmental officials that military man had a definite mission in space. The usual arguments for manned space flight such as decision-making and flexibility were inadequate. The subcommittee chairman stated that more specific reasons must be given or it was unlikely that extensive funds would be available for the development of manned space systems.<sup>20</sup>

The briefings to the President's Scientific Advisory Committee on October 10 essentially covered the findings concerning Gemini and the X-20 in the earlier May 10 report of the Air Force to Secretary McNamara. More detail, however, was presented on the use of the X-20 as a shuttle vehicle capable of rendezvous and docking. A configuration of the X-20 with an orbital development laboratory was also considered.<sup>21</sup> After completion of the presentations, Dr. Lees commented to Mr. Lamar that although he had previously been against the continuation of the Dyna-Soar program he now saw a definite need for the X-20. He would no longer oppose the program.<sup>22</sup>

By the end of October the purposes of the Dyna-Soar capability studies, which Secretary Zuckert had agreed to in July, were clarified. Following the instructions of Air Force headquarters, Lieutenant General H. M. Estes, AFSC Vice Commander, informed Major General R. G. Ruegg, ASD commander, that the purpose of the first study was to formulate a program of military space experiments involving only engineering changes to the X-20's subsystems. The Vice Commander added that this program of

experiments should be compared to a similar one employing the Gemini vehicle to insure that the Dyna-Soar approach offered the most economical and effective means of accomplishment. A second study would integrate the findings of various other studies and establish a series of mission models for reconnaissance, surveillance, satellite inspection, and also logistical support of a space station. A third study was to examine the future operational potential of reentry vehicles having a lift-to-drag ratio greater than the X-20. A final study would examine the economic implications of various modes of recovering space vehicles from near-earth orbit.<sup>23</sup> At the end of November, AFSC headquarters informed the X-20 office that Air Force headquarters had approved all but the second proposal which had just been submitted.<sup>24</sup> \*

Early in October 1963, General B. A. Schriever, AFSC Commander, informed ASD and SSD that the Secretary of Defense intended to visit the Martin Company facilities at Denver, Colorado, to receive briefings on the status of the X-20 and Titan III programs.<sup>25</sup> Colonel W. L. Moore, X-20 program director, later noted that the directions were somewhat in error because it became apparent during these presentations that Secretary McNamara desired far more than a status briefing.<sup>26</sup>

Prior to these briefings, there were numerous indications that the future of the Dyna-Soar program was uncertain. Several X-20 displays and activities had been planned for the Air Force Association convention which was to be held in the middle of September. One of the proposed events involved the continuous showing of a brief film on the nature and objectives of the Dyna-Soar program. Although this film was an updated version of

---

\*On December 16 AFSC headquarters canceled the first two studies, both of which dealt directly with the Dyna-Soar program.

one previously unclassified and released, the Office of the Secretary of Defense refused its clearance for the convention.<sup>27</sup> Furthermore, neither Dr. A. C. Hall, Deputy Director for Space in the Office of the Director of Defense for Research and Engineering, nor Dr. A. H. Flax, now Assistant Secretary of the Air Force Research and Development, indicated agreement to a briefing by the Air Force Plant Representative at Boeing on the necessity for manned military space flight.<sup>28</sup> It was reported that some X-20 Boeing officials became concerned over the future of the program after this visit.<sup>29</sup> In addition, the Director of Defense for Research and Engineering, Dr. Harold Brown, had not approved the release of funds for X-20's range requirements. The AFSC Vice Commander was concerned and considered that the range operational date of October 1965 for the Dyna-Soar program was certainly in jeopardy.<sup>30</sup> Lastly, Dr. Brown, in a speech before the United Aircraft Corporate Systems Center at Farmington, Connecticut, appeared critical of the Air Force manned space programs. He stated that both the Gemini and X-20 programs had very limited ability to answer the question of what man could do in space. Unless an affirmative answer were found, there would be no successor to these programs.<sup>31</sup>

A few days later, on October 23, Secretary McNamara accompanied by R. L. Gilpatric, Deputy Secretary of Defense; Harold Brown, and Brockway McMillan, now Under Secretary of the Air Force, were briefed by Titan III and X-20's officials. At the conclusion of his presentation, Colonel Moore stated that it would be desirable to have the Department of Defense publicly state its confidence in the Dyna-Soar program. The X-20's director then asked if there were any questions.<sup>32</sup>

Both Secretary McNamara and Dr. Brown asked a series of questions directed towards obtaining information on the necessity of manned military space systems. Secretary McNamara stated that the X-20 office had been authorized to study this problem since

March 1963. He emphasized that he considered this the most important part of the X-20 program. The Secretary of Defense wanted to know what was planned for the Dyna-Soar program after maneuverable reentry had been demonstrated. He insisted that he could not justify the expenditure of about \$1 billion for a program which had no ultimate purpose. He was not interested in further expenditures until he had an understanding of the possible space missions. Only then would the department give a vote of confidence to the X-20 program. Secretary McNamara then directed Dr. McMillan to get the answers.<sup>33</sup>

Some of the participants arrived at varying conclusions concerning the reaction of Secretary McNamara to the briefing. Mr. J. H. Goldie, Boeing's X-20 chief engineer, thought that the Secretary of Defense did not appear to be firmly against the X-20 nor in favor of Gemini. Rather, Secretary McNamara seemed willing to allow the Air Force to use the X-20 as a test craft and a military system if a case could be adequately made for a manned military space system.<sup>34</sup> Mr. Lamar concluded that the Secretary of Defense was not satisfied with the response and that "drastic consequences" were likely if an adequate reply were not made.<sup>35</sup> Colonel Moore prophetically stated that Secretary McNamara "probably will not ask us again."<sup>36</sup>

Just as serious as Secretary McNamara's reception of the X-20 briefing was the refusal of the Department of Defense to sanction a revision of the system package program. From May through September 1963, several changes involving the test organization and funding were made to the X-20 program. On May 9, 1963, General Schriever had directed that the Dyna-Soar orbital test program be assigned to the Space Systems Division. The AFSC Commander further ordered that the mission control center be located at the Satellite Test Center in Sunnyvale, California, instead of the Air Force Missile Test Center.<sup>37</sup> The May 27, 1963

system package program reflected this change in the test program and registered a requirement of \$135 million for fiscal year 1964.

While Air Force headquarters approved this system package program in June, the Department of Defense would only allow \$125 million for fiscal year 1964. On July 3 the Air Force Systems Command headquarters informed the X-20 office that attempts to obtain the higher funding level had failed.<sup>38</sup> The Director of Defense for Research and Engineering considered that the primary purpose of the program was to acquire data on maneuverable reentry. Incorporation of multiorbital flight was only of secondary importance, and the X-20 office could defer the first multiorbital flight date to remain within budget limitations.<sup>39</sup> AFSC headquarters then directed that a revised system package program be completed by early September.<sup>40</sup> Before this could be accomplished, General Schriever transferred not only orbital test direction to the space division but also responsibility for the air-drop program and the training of X-20 pilots.<sup>41</sup> These additional changes would also have to be incorporated into the revised system package program.

The September 3 program package presented the adjusted financial estimates and flight schedules. Considering that \$125 million had been authorized for fiscal year 1964 and a total of \$339.20 million had previously been expended, the program office estimated that \$139 million would be required for 1965, \$135.12 million for 1966, \$93.85 million for 1967, \$31.85 million for 1968, and \$3 million for 1969. The total cost for the Dyna-Soar program would amount to \$867.02 million. The reduction of fiscal year 1964 funds was absorbed by delaying the necessary modifications for multiorbital flight and deferring the date of the ninth ground-launch (the first multiorbital flight) from August 1967 to December 1967. The 20 air-launches were to occur from May 1965 through May 1966, and the two unmanned ground-



launches were to take place in January 1966 and April 1966. The first piloted ground-launch was to occur in July 1966, and the last piloted flight was to be conducted in February 1968.<sup>42</sup>

Soon after the issuing of this program package there was some concern over the expense involved in locating the mission control center at Sunnyvale. Colonel Moore estimated that this relocation would increase program costs by several million dollars.<sup>43</sup> Major General L. I. Davis, a special assistant to the AFSC Vice Commander, supported this argument by stating to General Schriever that many of the functions necessary for launch control were also necessary for mission control. It would be less expensive to keep both control centers at the Air Force Missile Test Center.<sup>44</sup>

At the request of AFSC headquarters, the X-20 office forwarded, on September 23, a revision of the September 3 system package program which detailed adjustments to program costs if the mission control center remained at Cape Canaveral. The X-20 office estimated that \$138.13 million would be required for fiscal year 1965, \$130.66 million for 1966, \$88.34 million for 1967 and \$31.09 million for 1968. The total program cost would amount to \$853.23 million instead of the previously estimated \$867.02 million.<sup>45</sup> On October 17, 1963, AFSC headquarters forwarded the system package program to the Air Staff, informing them that it was more feasible to locate the mission control center at the missile test center.<sup>46</sup> This program package did not receive the endorsement of either headquarters. As late as November 21, the X-20's assistant director, J. B. Trenholm, reminded AFSC headquarters that it would be beneficial to the program if the systems command would approve of the program package.<sup>47</sup>

It had been reported that, on the day following the October 23, 1963 briefing to Secretary McNamara, Dr. Brown had offered a manned orbiting laboratory program to the Air Force in

exchange for Air Force agreement to terminate the X-20 program. General C. E. LeMay, the Air Force Chief of Staff, did not agree and directed an Air Force group to prepare a rebuttal to such a proposal.<sup>48</sup> Previously, in August, Dr. Brown had approved an Air Force request to conduct a study of an orbital space station. He authorized the expenditure of \$1 million for fiscal year 1964. The Air Force was to focus on the reconnaissance mission with the objective of assessing the utility of man for military purposes in space. In determining the characteristics of such a station, the Air Force should consider the use of such programs as the X-15, the X-20, Mercury, Gemini, and Apollo. This study had to be concluded by early 1964.<sup>49</sup>

Before the completion of this space station study, however, Dr. Brown recommended a program for such an effort to Secretary McNamara in a November 14, 1963 memorandum. The Director of Defense for Research and Engineering analyzed varying sizes of space station systems which would incorporate either the Gemini or Apollo capsules as ferry vehicles and would employ either the Titan II, the Titan IIIC, or the Saturn IB booster. Two of the approaches were suitable. One would involve the use of the Lunar Excursion Module (LEM) adapter as a space station and the Saturn IB as the booster. The Apollo command module and the Titan IIIC would perform the logistics function. Dr. Brown estimated that this approach would cost \$1.286 billion from fiscal years 1964 through 1969. The first manned ferry launch could take place in late 1966, and active station tests could be conducted by late 1967.

The alternative which the Director of Defense for Research and Engineering preferred was to develop a space station with provisions for four men, use the Gemini capsule as a ferry vehicle, and separately launch both the station and capsule with a Titan IIIC booster. From fiscal years 1964 through 1968, this approach would total \$983 million. The first manned ferry launch

could occur in the middle of 1966, and active space station tests could begin in the middle of 1967.

Dr. Brown, however, was concerned because both of the recommended approaches would employ primitive landing methods, and, consequently, he suggested the development of a low lift-to-drag ratio vehicle which could perform maneuverable reentry and conventional landing. The Director of Defense for Research and Engineering suggested that models of such a craft be tested in the Aerothermodynamic Structural Systems Environmental Test program (ASSET) during 1964 and 1965, and he estimated that an improved ferry vehicle could be available for later station tests. The total for this more sophisticated vehicle program would amount to \$443 million for fiscal years 1964 through 1968.

Dr. Brown's recommendation to Secretary McNamara was brief: cancel the X-20 program and initiate the Gemini approach to a manned military space station. Management of the Gemini program should be transferred from NASA to the Department of Defense by October 1965.<sup>50</sup>

Discussions between National Aeronautics and Space Administration and Department of Defense officials made it clear that the space agency would agree to a coordinated military space program, but it was not prepared to support a space station program. Instead NASA suggested a program for an orbiting military laboratory which did not involve ferrying, docking, and resupplying. On November 30 Dr. Brown, in another memorandum to Secretary McNamara, analyzed an approach more agreeable to NASA. This alternative would involve the orbiting by a Titan IIIC booster of a Gemini capsule and a 1,500 cubic foot test module, capable of supporting two to four men for 30 days. Dr. Brown maintained that such an approach could easily be converted into the Gemini alternative he had recommended on November 14. This simplified

approach would total \$730 million from fiscal year 1964 through 1968, and the manned orbital test program could be conducted in late 1967. Dr. Brown, however, advised the Secretary of Defense that the space station proposal of November 14 was still the most feasible and should be initiated.<sup>51</sup>

While NASA had suggested a simplified Gemini approach, it by no means concurred with the proposed termination of the X-20 program. The Associate Administrator for Advanced Research and Technology, Dr. R. L. Bisplinghoff, pointed out that advanced flight system studies had repeatedly shown the importance of developing the technology of maneuverable hypersonic vehicles with high-temperature, radiation-cooled metal structures. Test facilities were unable to simulate this lifting reentry environment, and, consequently, X-20 flights were necessary to provide such data. NASA had always supported the Dyna-Soar program and should it be canceled the space agency would have to initiate a substitute program.<sup>52</sup>

In order to achieve the objective of obtaining data on reentry, Dr. Bisplinghoff recommended some changes to the Dyna-Soar program. After completion of an adequate air-drop program and a satisfactory unmanned ground-launch flight, a piloted orbital flight should be conducted.<sup>53</sup> Dr. Brown requested Dr. Flax to examine such an alternative for the X-20.<sup>54</sup> With the assistance of the X-20 program office and AFSC headquarters, Dr. Flax completed his reply on December 4. He estimated that such a curtailed program would reduce the total cost by \$174.4 million through fiscal year 1969. He pointed out, however, that such an approach would result in the loss of technical data which would be disproportionate to the financial savings.<sup>55</sup>

On the same day, in another memorandum to the Secretary of the Air Force, Dr. Flax firmly disagreed with the recommendations of

Dr. Brown's November 14 memorandum. The Assistant Secretary pointed out that the X-20 had not been given serious consideration as an element in any of the space station proposals. He emphasized that major modifications were necessary to both the Gemini and the X-20 if either were to be employed in an orbital station program. Furthermore, the Dyna-Soar approach possessed several advantages: the vehicle could make emergency landings without the costly deployment of air and sea elements and there would be a more tolerable force of vehicle deceleration during reentry. Dr. Flax continued by emphasizing the importance of the X-20 program. Its technology not only supported the development of reentry vehicles, including Dr. Brown's improved ferry vehicle, but also an entire class of hypersonic winged-vehicles. Since about \$400 million had already been expended on the X-20 program, the Assistant Secretary severely questioned the proposal to cancel Dyna-Soar and initiate a new program with similar objectives. While he endorsed the purposes of the space station program, Dr. Flax believed that the decision to begin such a program was independent of the question to terminate the X-20.<sup>56</sup>

On the same day, Secretary of the Air Force Zuckert forwarded Dr. Flax's memorandum to Secretary of Defense McNamara with the statement that it represented the best technical advice available in the Air Force. The Secretary of the Air Force added that both he and Dr. Brockway McMillan were in accord with Dr. Flax's position. Secretary Zuckert further stated that he did not wish to see the Air Force abandon a program such as Dyna-Soar and start a new program which perhaps had been projected upon optimistic schedules and costs.<sup>57</sup>

As an Air Force reply to Dr. Brown's November 14 memorandum, Major General J. K. Hester, the Assistant Vice Chief of Staff, suggested to the Secretary of the Air Force several alternatives for varying sizes of space stations, all of which employed the X-20

vehicle. The first alternative offered an extended X-20 transition section which would provide a module of 700 cubic feet. This would be a two-man station employing an X-20 launched by a Titan IIIC. The second approach comprised a separately launched two-room station by the Titan II. This would have 1,000 cubic feet of volume and would be serviced by an X-20 shuttle vehicle boosted with a Titan IIIC. The third alternative, recommended by General Hester as the most feasible, involved a five-man station launched by Titan IIIC and capable of orbiting for one year. This approach would require \$978.4 million from fiscal years 1964 through 1969 for the development of a space station and the X-20 ferry vehicle. The Assistant Vice Chief of Staff considered that the first space station launch could take place by the middle of 1967. With an X-20 approach to a space station program, it was not necessary to have a separate program for an improved ferry vehicle. Rather, only an annual funding level of \$6.4 million for the ASSET program was necessary to advance space technology. General Hester therefore recommended the initiation of a space station program employing the X-20 and, if economy were essential, the cancellation of the Gemini program.<sup>58</sup>

On the next day, Secretary Zuckert forwarded General Hester's memorandum to Secretary McNamara. The Air Force Secretary stated that the Air Staff study clearly indicated that there was no definite reason for omitting the X-20 from consideration as a reentry vehicle for an orbital space station or orbital laboratory program. This was particularly important because of safety and cost advantages which the X-20 offered for long duration orbital missions. Secretary Zuckert believed that the X-20's alternative deserved serious consideration.<sup>59</sup>

On December 8 a rumor circulated in Air Force headquarters that the Defense Department had reduced X-20's fiscal year 1964 funds from \$125 million to \$80 million and had not allocated any money

for fiscal year 1965.<sup>60</sup> The next day defense officials conferred with President Johnson. Apparently, Secretary McNamara recommended the termination of Dyna-Soar, and the President agreed.<sup>61</sup> On December 10 the Secretary of Defense announced the cancellation of the X-20 project. The program had been reviewed, alternatives studied, and the decision made. In its place would be a manned orbital laboratory (the NASA proposal which Dr. Brown explained in his November 30, 1963 memorandum). The Secretary of Defense also stated that there would be an expanded ASSET program (the improved ferry vehicle program which Dr. Brown offered in his November 14 memorandum) to explore a wide range of reentry shapes and techniques. By taking the Gemini approach to a space program, Secretary McNamara estimated that \$100 million would be saved in the following 18 months.

The Secretary of Defense explained his reasons for canceling the X-20. He stated that the purpose of the program had been to demonstrate maneuverable reentry and landing at a precise point. The Dyna-Soar vehicle was not intended to develop a capability for carrying on space logistics operations. Furthermore, the X-20 was not intended to place substantial payloads into space nor fulfill extended orbital missions. The Secretary of Defense stated that about \$400 million had already been expended on a program which still required several hundred million dollars more to achieve a very narrow objective.<sup>62</sup>

A few days after the termination announcement Dr. Brown, in a memorandum to the Secretary of the Air Force, replied to the arguments of Dr. Flax and General Hester. Dr. Brown stated that before reaching a decision the Air Force alternatives were carefully considered. There were three objections. The Air Force recommended program involved construction of a space station and a new and larger X-20. The Department of Defense considered that such a large step was not justified and a test module and Gemini

vehicle were chosen as the logical first step. Furthermore, the Air Force suggestion to cancel Gemini was not within the power of the Department of Defense since this was a NASA program. Lastly, the Air Force recommendation involved a greater degree of schedule risk than the chosen program. The Air Force proposal could not be accepted as a feasible substitute for the Manned Orbiting Laboratory program.<sup>63</sup>

Following Secretary McNamara's news conference on December 10, Air Force headquarters informed all of its commands of the termination of the X-20 and the initiation of an orbital laboratory program.<sup>64</sup> On the same day, General Schriever met with some of his staff to discuss the new space approach. He stated that both the orbiting laboratory and the expanded ASSET programs would be placed under the management of the Space Systems Division.<sup>65</sup> Later, General Schriever requested the Commander of the Research and Technology Division, Major General Marvin C. Demler, to aid the space division in the preparation of a new ASSET development plan. The objective of this program as first announced by Dr. Brown remained unchanged: the development of an advanced ferry vehicle.<sup>66</sup>

Although official instructions were not received from AFSC headquarters until December 17, the X-20 program office instructed the Dyna-Soar contractors and various Air Force agencies on December 10 to stop all activities involving the expenditure of X-20's funds.<sup>67</sup> On the next day Secretary Zuckert authorized the Air Force to terminate the X-20 program; however, it was to continue certain X-20 efforts which were deemed important to other space programs. A preliminary report was due no later than December 16.<sup>68</sup> The day following this direction the ASD program office recommended the continuation of ten activities: studies of pilot control of booster trajectories, fabrication of the Dyna-Soar heat protection system, construction of the full pressure suit,



fabrication and testing of the high temperature elevon bearings, final development testing of the nose cap, flight testing on the ASSET vehicle of coated molybdenum panels, final acceptance testing of the test instrumentation subsystem ground station, development of the very high frequency (VHF) search and rescue receiver and transmitter, employment of existing Boeing simulator crew station and flight instruments for further research, and development of certain sensing and transducing equipment for telemetry instrumentation.<sup>69</sup> On December 18 Air Force headquarters informed the program office that the Secretary of the Air Force had approved the ten items, and funding for continuation of these contracts would be limited to \$200,000 a month.<sup>70</sup>

The X-20's engineering office, however, had recommended a list of several items for reinstatement which were in addition to the ten efforts continued by the program director. The X-20's Program Director had not supported the engineering office items either because he did not consider them of sufficiently wide applicability or he could not adequately establish their merit.<sup>71</sup> This list, however, was revised on December 14 by representatives from AFSC headquarters, the Space Systems Division, the Aeronautical Systems Division, and the Research and Technology Division. The officials decided to identify the items not only by technical area, as originally presented by the engineering office, but also by four categories. Category A involved efforts whose cost for completion would be equal to the termination expense. Category B comprised items which were applicable to various space programs. Category C included items which would contribute to the advancement of the state-of-the-art. The final classification, Category D, contained efforts which possessed a potential future use.<sup>72</sup>

On December 20, 1963 a revision of this list had been completed and coordinated with the laboratories of the Research and Technology Division. The items were classified both by technical

area and the suggested categories. At the end of the month officials from USAF headquarters, AFSC headquarters, ASD, and RTD again reviewed proposed items for continuation and this time a new classification was suggested. Category I included items which would advance the state-of-the-art. Category II involved items which only required feasibility demonstration or design verification. Category III comprised equipment which was nearly completed, and Category IV were efforts which necessitated further justification.<sup>73</sup>

By January 3, 1964, a last revision of the proposed useful efforts had been completed. A Category V was added which included items that had been suggested for continuation by various organizations but were considered unacceptable by the X-20's engineering office. Essentially, the engineering office recommended for continuation the 38 efforts which comprised Categories I, II, and III. Included in these were the ten items which were being continued by the program office itself. A few days later General Estes requested from USAF headquarters authority to retain sufficient funds for program termination which would include \$3.1 million for the completion of the first three categories.<sup>74</sup> On January 23 USAF headquarters informed AFSC that the Secretary of the Air Force had approved, with the exception of two items, all the efforts listed under the first three categories. The Air Force would allow an expenditure of \$70 million from fiscal year 1964 funds for the Dyna-Soar program, \$2.09 million of which would be directed towards completing the three categories.<sup>75</sup> The Research and Technology Division was then assigned authority to formulate a management plan for completion of this work.<sup>76</sup> The X-20's engineering office completed a plan at the end of January recommending that separate contracts be negotiated for the three categories of items which had not been already reinstated. These contracts would be administrated by the Research and Technology Division except for two which were to be transferred to the Air

Force Missile Development Center and the Air Force Flight Test Center.<sup>77</sup> While Air Force headquarters did not give an official approval, this plan was put into operation.

The Air Force calculated that Boeing had completed 41.74 percent of its tasks. The Minneapolis-Honeywell Regulator Company, the associate contractor for the primary guidance subsystem, had finished 58 percent, and the Radio Corporation of America, the associate contractor for the communication and tracking subsystem, had completed 59 percent of its work. At the time of Secretary McNamara's announcement, Boeing had 6,475 people involved in the X-20 program, while Minneapolis-Honeywell had 630 and RCA, 565. The governmental expenditure for these contracts amounted to \$410 million.<sup>78</sup>

While it had only approximately reached mid-point, the Dyna-Soar program definitely advanced the technology of radiation-cooled structures. Thirty-six X-20 tasks were continued and would directly contribute to other Air Force space efforts. Also significant was the initiation of an expanded ASSET program directed towards the development of a lifting, reentry shuttle vehicle. Paradoxically, the cancellation of X-20's development apparently made the maneuverable reentry concept far more acceptable to the Department of Defense and some elements of the Air Force than it had during the existence of the Dyna-Soar program.

## NOTES

1. TWX, AFSDC-85081, Hq. USAF to Hq. AFSC, Dec. 11, 1961; SPD, DCS/Sys. & Log., Hq. USAF, Dec. 27, 1961.
2. Memo., R. S. McNamara, Secy. of Def. to E. M. Zuckert, SAF, Feb. 23, 1962, subj.: The Air Force Manned Military Space Program.
3. Memo., Secy. of Def. to Harold Brown, DDR&E, Jan. 18, 1963.
4. Memo., Brockway McMillan, ASAF/R&D to SAF, Mar. 15, 1963.
5. Memo., ASAF/R&D to SAF, Mar. 18, 1963.
6. Rpt., Dep/Tech., SSD, May 10, 1963, subj.: Response to Secretary McNamara's March 15, 1963 Questions, I, 2-19 to 2-23, 2-27 to 2-29, 2-37, 2-47c, 2-47h.
7. Ibid., 2-54c to 2-54j, 2-55 to 2-57, 2-63, 2-79, 2-87.
8. Ibid., ix-xiii.
9. Ltr., Maj. Gen. O. J. Ritland, Dep. to the Cmdr/Manned Space Flight, Hq. AFSC to Hq. USAF, May 22, 1963, subj.: Response to Secretary McNamara's March 15, 1963 Questions.
10. Memo., ASAF/R&D to Secy. of Def., June 5, 1963, subj.: Review of Air Force Space R&D Program.
11. Rpt., X-20 SPO, ASD, June 1, 1963, subj.: X-20 Anti-Satellite Mission, pp. 7, 8, 12, 21.
12. Ltr., Col. W. D. Brady, Acting Dep/Tech., SSD to Col. W. L. Moore, Prog. Dir., X-20 SPO, June 25, 1963, subj.: Program 706, Phase O Study.
13. Rpt., X-20 SPO, Nov. 18, 1963, subj.: Phase O Study of X-20 Program 706, I, 2, 14, 15.
14. Presn., W. E. Lamar, Dir., X-20 Engg. Ofc., RTD to SAF, July 8, 1963, subj.: X-20 Status Report.
15. Minutes, Col. C. R. Tosti, Exec. Secy., DSMG, Hq. USAF, July 23, 1963, subj.: Sixty-fifth Meeting, Designated Systems Management Group, July 12, 1963.
16. Memo., L. B. Johnson, Vice Pres. to R. S. McNamara, Secy. of Def., July 22, 1963, subj.: Space Stations.
17. Memo., McNamara to Johnson, Aug. 9, 1963, subj.: Orbital Space Station.

18. Memo., N. E. Golovin, Ofc., Science and Tech., Exec. Ofc. of the Pres. to A. C. Hall, Dep. DDR&E, Sept. 12, 1963, subj.: Briefing for Lees Subcommittee of PSAC Space Vehicle Panel.
19. Ltr., Maj. Gen. W. B. Keese, DCS/Plans, Hq. USAF to Hq. ASD, Sept. 19, 1963, subj.: Briefing to PSAC Panel on October 10, 1963.
20. Trip rpt., Lamar, Sept. 23, 1963, subj.: Briefing for President's Advisory Committee--Space Vehicle Panel.
21. Rpt. to PSAC, Hq. USAF, Oct. 10, 1963, subj.: Manned Orbiting Station and Alternatives, Vol. IV.
22. Interview, Lamar by C. J. Geiger, Hist. Div., ASD, Jan. 14, 1964.
23. Memo., A. H. Flax, ASAF/R&D, Hq. USAF, Sept. 18, 1963, subj.: Dyna-Soar Operational Capability Study; ltr., Lt. Gen. H. M. Estes, Vice Cmdr., AFSC to Hq. ASD, Oct. 25, 1963, subj.: Space Planning Studies.
24. TWX, SCLDS-27-11-3, Hq. AFSC to Hq. ASD, Nov. 29, 1963.
25. TWX, SCG-0-10-6, Hq. AFSC to Hq. ASD, Oct. 10, 1963.
26. Memo., Col. Moore, Oct. 30, 1963, subj.: Record Memorandum of the X-20 Presentation to Secretary of Defense McNamara, October 23, 1963, and Pertinent Background.
27. Hist. Rpt., Dir., Dev., DCS/R&D, Hq. USAF, July-Dec. 1963, p. 77.
28. Ltr., Col. W. H. Price, AFPR, Boeing Co. to Hq. AFSC, Oct. 10, 1963, subj.: Report of Visit, Assistant Secretary of the Air Force.
29. Interview, Lamar by Geiger, Feb. 27, 1964.
30. Hist. Rpt., Dir., Dev., DCS/R&D, Hq. USAF, July-Dec. 1963, p. 77; ltr., Lt. Gen. Estes to Lt. Gen. James Ferguson, DCS/R&D, Hq. USAF, Oct. 17, 1963, subj.: X-20A System Package Program.
31. Speech, Harold Brown, DDR&E, Oct. 17, 1963, subj.: National Space Program.
32. Memo., Col. Moore, Oct. 30, 1963, subj.: Record Memorandum of X-20 Presentation to Secretary of Defense McNamara, October 23, 1963, and Pertinent Background.
33. Trip rpt., Lamar, subj.: Paraphrased Transcript of Discussion After X-20 Status Briefing to Mr. McNamara by Col. Moore in Denver, October 23, 1963.

34. Trip rpt., J. H. Goldie, Boeing Co., Oct. 24, 1963, subj.: Questions, Comments, and Impressions from McNamara Briefing in Denver, October 23, 1963.
35. Trip rpt., Lamar, subj.: Paraphrased Transcript.
36. Memo., Col. Moore, Oct. 24, 1963, subj.: X-20A Status Report to Secretary McNamara, October 23, 1963.
37. Ltr., Gen. B. A. Schriever, Cmdr., AFSC to Hq. ASD, May 9, 1963, subj.: X-20 Program Management.
38. TWX, SCCP-3-7-2, Hq. AFSC to Hq. ASD, July 3, 1963.
39. Memo., DDR&E, subj.: Rationale of FY 64 RDT&E Program Adjustments by OSD.
40. TWX, MSFA-30-7-47, Hq. AFSC to Hq. ASD, July 30, 1963.
41. Ltr., Gen. Schriever to Cmdr., ASD, July 31, 1963, subj.: X-20 Program.
42. System Package Program, System 620A, X-20 SPO, Sept. 3, 1963, pp. 11-1, 11-3, 11-5.
43. Memo., Col. Moore, Sept. 9, 1963, subj.: X-20 Test Program.
44. Ltr., Maj. Gen. L. I. Davis, Spec. Asst. to Vice Cmdr., AFSC to Gen. Schriever, Sept. 19, 1963.
45. Revision A, System Package Program, System 620A, X-20 SPO, Sept. 3, 1963, p. 11-3.
46. Ltr., Lt. Gen. Estes to Lt. Gen. Ferguson, Oct. 17, 1963, subj.: X-20A System Package Program.
47. Ltr., J. B. Trenholm, Asst. Dir., X-20 SPO to Lt. Col. C. L. Scoville, Dir., Mil. Space Prog., Hq. AFSC, Nov. 21, 1963.
48. Memo., Lt. Col. Scoville.
49. Memo., DDR&E to SAF, Aug. 30, 1963, subj.: Military Orbiting Space Station.
50. Memo., DDR&E to Secy. of Def., Nov. 14, 1963, subj.: Approaches to a Manned Military Space Program.
51. Memo., DDR&E to Secy. of Def. Nov. 30, 1963, subj.: Evaluation of an Orbital Test Module.

52. Ltr., R. L. Bisplinghoff, Assoc. Adm/Adv. Res. & Tech., NASA to Assoc. Adm., NASA, Nov. 22, 1963, subj.: X-20 Program.
53. Ibid.
54. Memo., DDR&E to ASAF/R&D, Nov. 29, 1963, subj.: X-20 Program.
55. Memo., Col. Moore, Dec. 3, 1963, subj.: Telephone Request from Hq. AFSC; memo., ASAF/R&D to DDR&E, Dec. 4, 1963, subj.: X-20A Program.
56. Memo., ASAF/R&D to SAF, Dec. 4, 1963, subj.: Manned Military Space Program.
57. Memo., SAF to Secy. of Def., Dec. 4, 1963, subj.: Manned Military Space Program, as noted by Max Rosenberg, Hist. Div., Liaison Ofc., Hq. USAF.
58. Memo., Maj. Gen. J. K. Hester, Asst. VCS/AF to SAF, Dec. 4, 1963, subj.: Approaches to a Manned Military Space Program.
59. Memo., SAF to Secy. of Def., Dec. 5, 1963, subj.: Manned Military Space Program, as noted by Rosenberg.
60. Hist. Rpt., Dir., Dev., DCS/R&D, Hq. USAF, July-Dec. 1963, p. 81.
61. New York Times, Dec. 10, 1963.
62. News Briefing, Secy. of Def., Dec. 10, 1963.
63. Memo., DDR&E to SAF, Dec. 12, 1963, subj.: X-20 Program.
64. TWX, AFCVC-1918/63, Hq. USAF to All Commands, Dec. 10, 1963.
65. Memo., Lt. Col. Scoville.
66. Ltr., Gen. Schriever to Maj. Gen. Marvin C. Demler, Cmdr., RTD, Dec. 16, 1963, subj.: Manned Space Program.
67. TWX, ASZR-10-12-1011, Hq. ASD to Hq. SSD, Dec. 10, 1963; TWX, ASZRK-12-10-249, Hq. ASD to AFPR, Boeing Co., Dec. 10, 1963.
68. TWX, SAF to Hq. AFSC, Dec. 11, 1963; memo., SAF to CS/AF, Dec. 12, 1963, subj.: Dyna-Soar Termination.
69. X-20 Phase-out Plan, X-20 SPO, Dec. 13, 1963, pp. IV-1 to IV-11.
70. TWX, AFRDD-79094, CS/AF to Hq. AFSC, Dec. 18, 1963.

71. X-20 Phase-out Plan, X-20 SPO, Dec. 13, 1963, p. IV-1.
72. TWX, MSF-17-12-45, Hq. AFSC to Hq. ASD, Dec. 17, 1963.
73. X-20 Detailed Termination Plan, X-20 SPO, Jan. 3, 1964, p. IV-18.
74. Ltr., Lt. Gen. Estes to Hq. USAF, Jan. 8, 1964, subj.: X-20A Technology.
75. TWX, AFRDDG-86985, Hq. USAF to Hq. AFSC, Jan. 23, 1964.
76. TWX, MSFAM-16-1-38, Hq. AFSC to Hq. ASD, Jan. 16, 1964.
77. Management Plan for X-20 Continuation Tasks, X-20 Engg. Ofc., RTD, Jan. 31, 1964, pp. 4-5.
78. Ltr., P. J. DiSalvo, Dep. Dir/Procurement, X-20 SPO to AFPR, Boeing Co., Mar. 12, 1964, subj.: AF33(657)-7132, The Boeing Company Percentage of Completion and SPO Recommendations for Final Settlement; ltr., DiSalvo to AFPR, Minneapolis-Honeywell Regulator Co., Feb. 27, 1964, subj.: AF33(657)-7133, Minneapolis-Honeywell Regulator Company Percentage of Completion and SPO Recommendation for Final Settlement; ltr., DiSalvo to AFPR, RCA, Mar. 30, 1964, subj.: Contract AF33(657)-7134, Radio Corporation of America, Percentage of Completion and SPO Recommendation for Final Settlement; X-20 Detailed Termination Plan, X-20 SPO, Jan. 23, 1964, p. III-2; interview, DiSalvo, Acting Ch., Hitting Msl. SPO, by Geiger, Aug. 5, 1964.



## CHAPTER VI

### X-20: THE TECHNICAL LEGACY

Termination of the X-20 effort did not immediately result in a shutdown of all X-20-related work. Testing of various X-20 components and design features continued well into the middle 1960's, using both ground test facilities and such flight research vehicles as the ASSET. The X-20 had a profound impact upon the state of technical knowledge regarding hypersonic flight, and over the spring and early summer of 1964, the Boeing Company assembled a comprehensive "lessons learned" document, Report D2-23418, highlighting the technical advances that had been made in support of the X-20's development effort. This document stands as the clearest technical analysis of the program and what was achieved--as well as what remained to be done--that is available. It has been edited and excerpted here as the final chapter of the X-20 case study:<sup>1</sup>

The purpose of the X-20 program was to develop and demonstrate a piloted research vehicle capable of orbital flight, controlled maneuverable entry from orbit, extensive exploration of the hypersonic flight regime, and horizontal landing at a designated location. Because of its broad scope, the program represented the deepest penetration into lifting entry technology that has been made. The advances made by the X-20 effort range from the development of theoretical concepts to the implementation of flight hardware.

More than 16 million man-hours were devoted to the X-20 program of which 11 million were spent on engineering. Over 14 thousand

hours of wind tunnel tests and nearly 9 thousand hours of simulator time were required to achieve the final design. In addition to the advanced technical requirements of the X-20, a substantial number of man-hours were devoted to systems engineering, glider-booster integration, associate contractor coordination, and subcontractor management.

This document presents a cross section of the technical advances of the X-20 program. Particular emphasis has been placed on aerodynamics, structures and materials, and subsystems. The technical advances made during the X-20's development are applicable to both current and future programs.

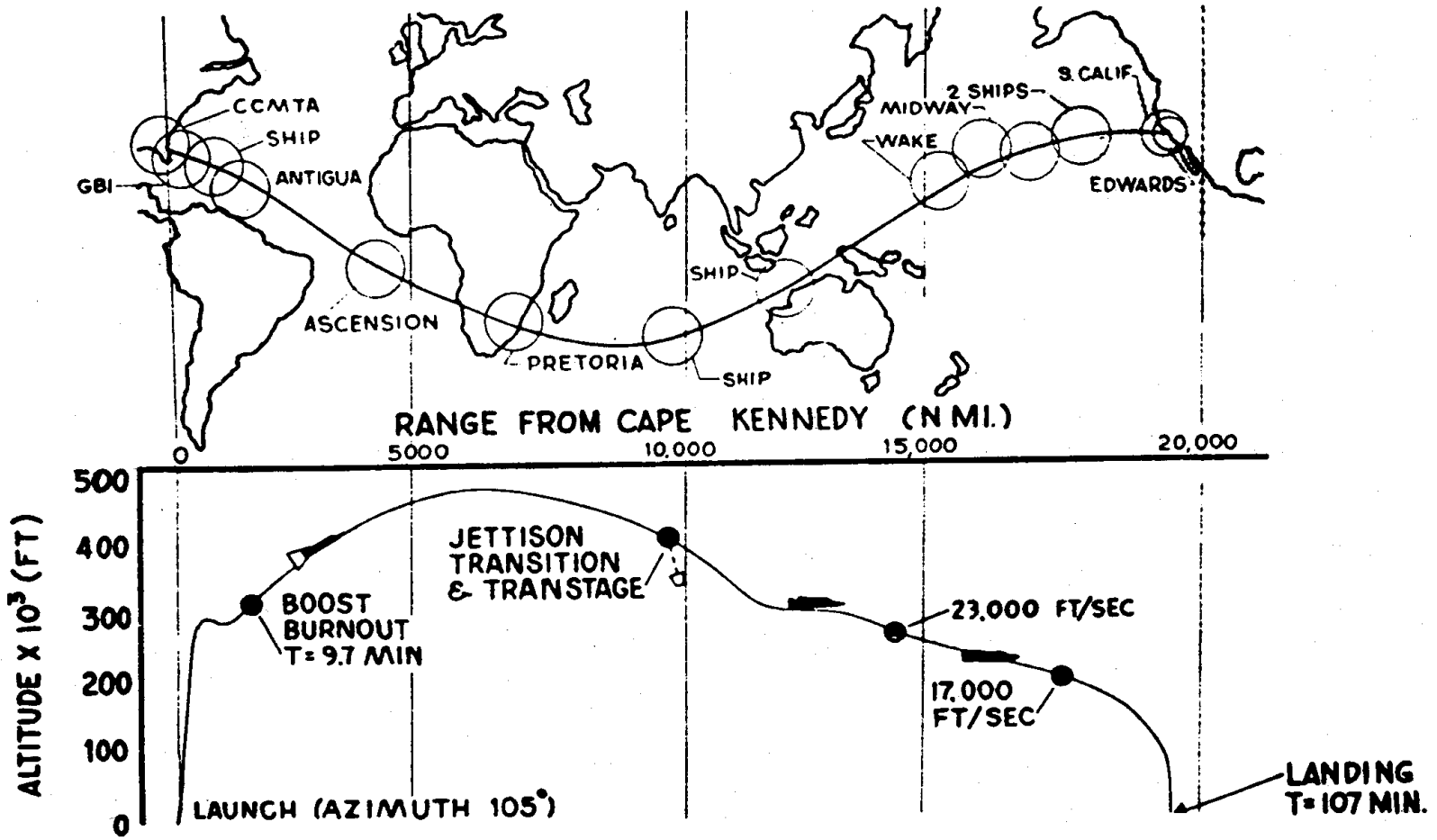
#### Mission Profile

A typical one-orbit flight profile for the X-20 glider is shown in Figure 1. The orbital vehicle was to be boosted eastward from Cape Kennedy to a velocity of 24,470 feet per second and an altitude of 320,000 feet at boost burnout. The vehicle then coasted to apogee at 480,000 feet. Separation from transition and transtage was to occur at initiation of entry. The glider would then proceed to a landing 107 minutes later at Edwards Air Force Base. Critical entry heating would have occurred over the Pacific Ocean at velocities between 17,000 and 24,000 feet per second.

#### Aerodynamics and Flight Performance

This section contains technical information developed during design of the X-20 glider in the areas of aerodynamics, flight mechanics, flight controls, and aerothermodynamics. This technical information ranges from detail configuration effects on stability and local heating to recommended techniques for hypersonic flight. Over 14,000 wind tunnel test hours, which included 1800 hours subsonic, 3700 hours supersonic, and 8500 hours hypersonic,

Figure 1



together with almost 9000 hours of simulator time, were required to arrive at the final design of the X-20.

### X-20 Configuration

The specific design, flight, and operating constraints for the X-20 glider were complex and required unique design solutions. The most demanding of these requirements included atmosphere entry at orbital speed, flight to designated location with horizontal landing, attainment of 1500 nautical mile lateral range capability, attainment of hypersonic L/D ratio of 1.5 or more, attainment of hypersonic lift coefficient of 0.6 or more, maintenance of positive static stability throughout flight, and capability of manned abort throughout the mission. The flight regime operating limits were a dynamic pressure range of 0 to 900 psf (the latter in case of an abort during boost), a velocity range of Mach 0.3 to 30, and an angle-of-attack range of 18 to 55 degrees during hypersonic flight. Further design requirements included a radiation-cooled structure capable of surviving the entry thermal environment for 4 missions, a payload capacity of 75 cubic feet and 1000 pounds, attainment of 91.3 percent glider flight reliability and 96 percent pilot safety, and a maximum glider and transition section gross weight of 18,000 pounds.

Extensive trade studies and configuration tailoring were accomplished to meet the required design and flight characteristics. Following are some of the design compromises made after these trade studies were completed.

1. Wing sweep and leading-edge radius were a compromise between the hypersonic and subsonic L/D ratio and the stagnation-line heating limit imposed by the thermal qualities of available refractory materials.

2. The fins were located outboard to provide stability and yaw control at high angles of attack during hypersonic flight.

3. The fins were toed in 10 degrees to take advantage of increased hypersonic lift curve slope and reduce required fin area. The toe-in angle was a compromise with increased weight from higher fin loads during boost and increased drag during flight.

4. The fin sweep and leading-edge radius were a compromise among effects on interference heating, subsonic lift curve slope, transonic shock stall characteristics, and supersonic rudder hinge moments.

These design analyses and analytical techniques developed during the X-20 program are applicable to other lifting entry vehicle programs.

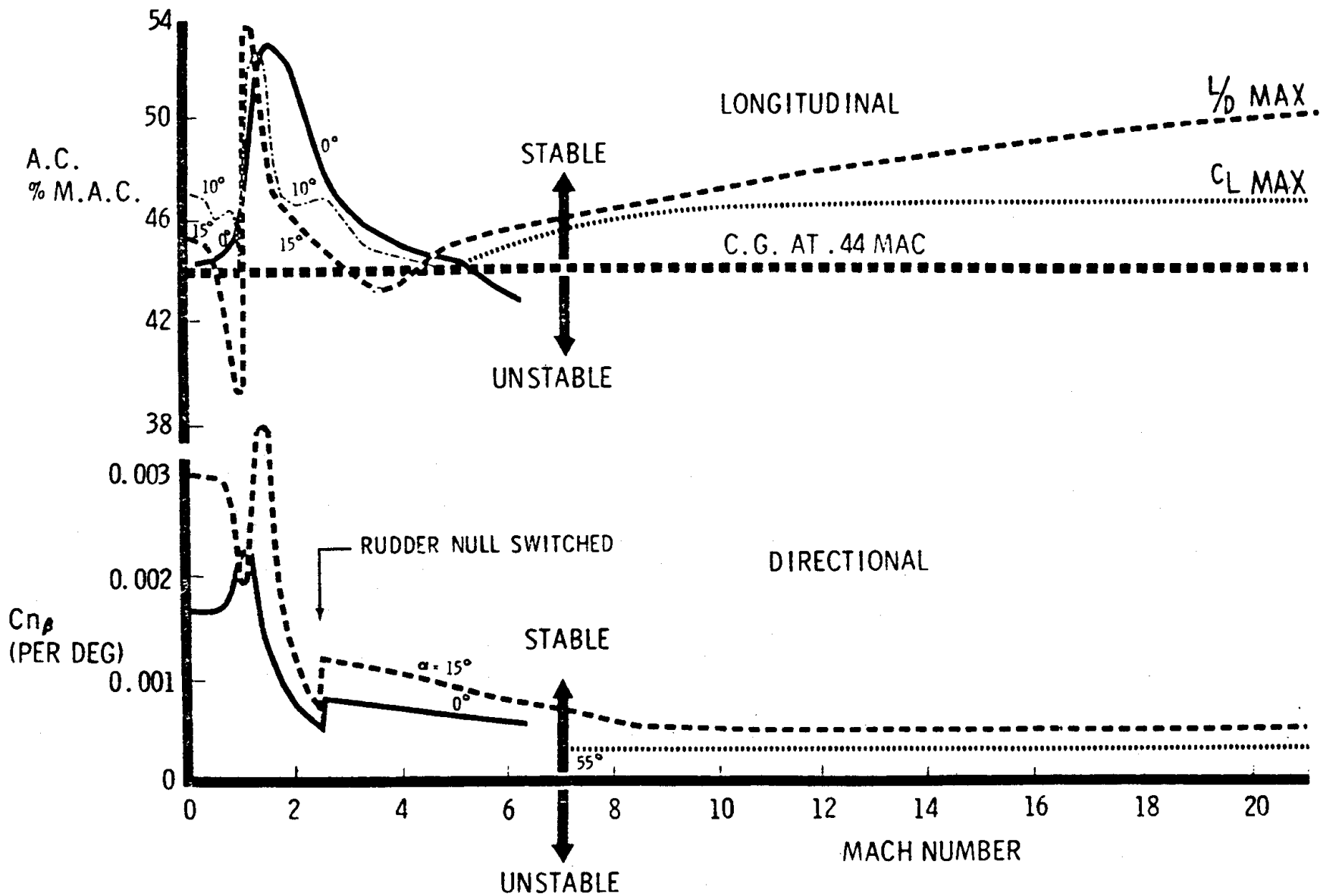
#### X-20 Static Stability

During X-20's development, a design goal was established to achieve a statically stable glider within the normal range of entry and glide conditions. This was done to ease the task of the flight control system; to provide satisfactory augmented handling qualities; and to provide satisfactory unaugmented handling qualities to the extent possible.

Static longitudinal stability is presented in Figure 2 as trimmed aerodynamic center for various angles of attack through the speed range of the glider. An instability existed for a small range of high subsonic Mach numbers at high angles of attack. An instability also existed at supersonic speeds at intermediate angles of attack, although this instability was small (approximately 1 percent m.a.c.) and disappeared at higher angles of attack. Also, as shown on the figure, static directional



Figure 2



stability existed through the complete range of required flight conditions.

In summary, the glider provides satisfactory handling qualities (Cooper ratings from 1 to 3) under the normal range of entry and glide conditions with stability augmentation. In addition, the aerodynamic stability configuration made emergency control (Cooper ratings less than 6.5) possible at all Mach numbers with either pitch axis or the lateral-directional axes unaugmented. Also, emergency control was possible for many flight conditions with complete loss of augmentation.

#### Aerodynamic Interaction Effects

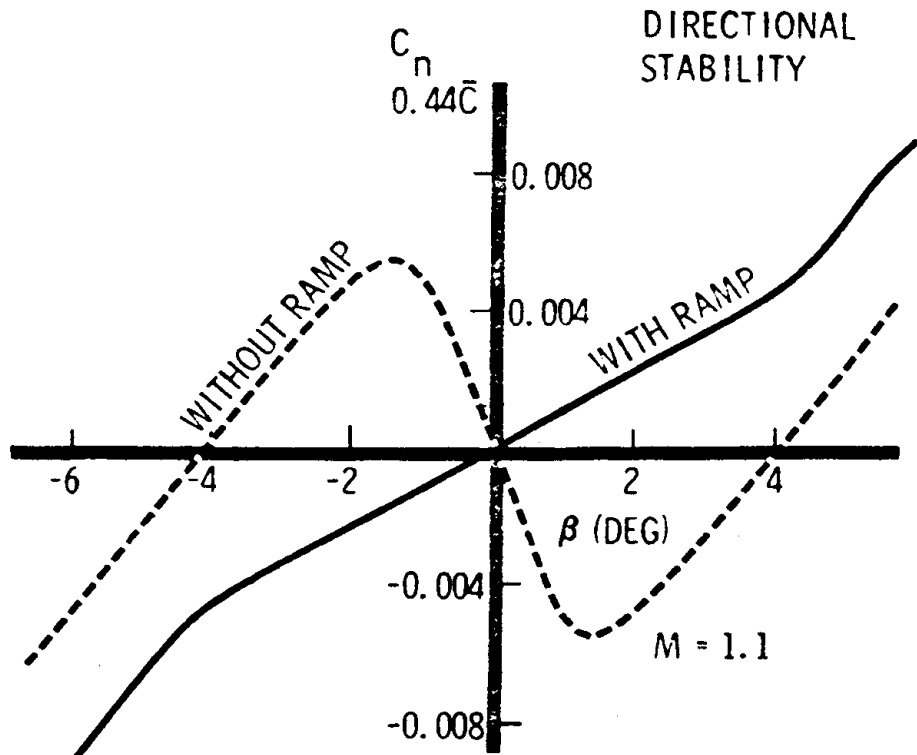
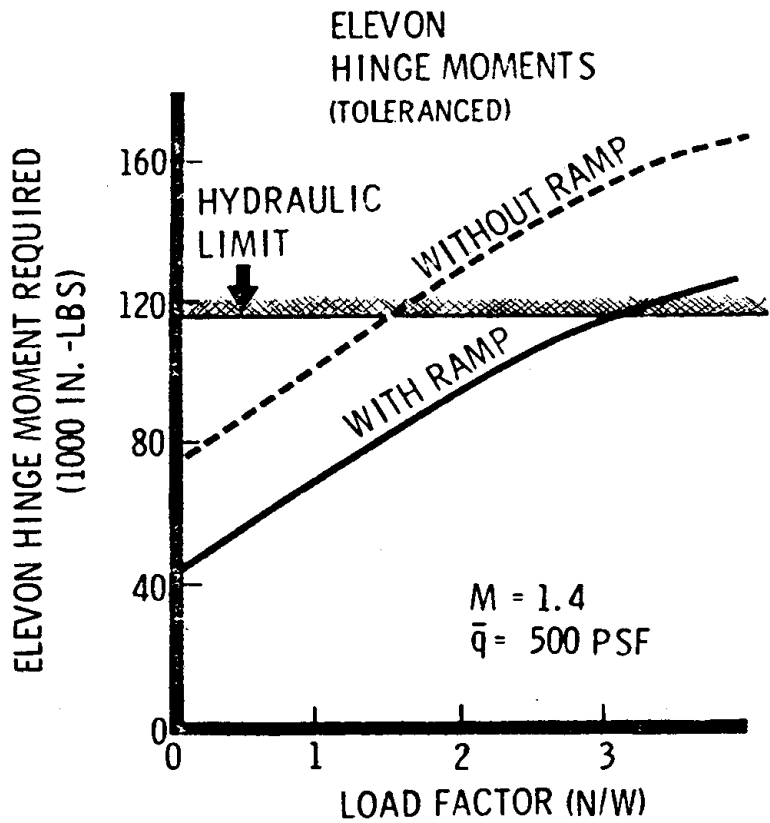
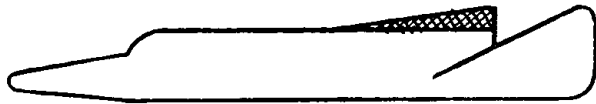
The interaction of aerodynamic effects may complicate configuration design, requiring tailoring and refinements not usually considered in preliminary analyses. Following are two examples of configuration tailoring to overcome aerodynamic interaction effects.

The basic wing section on the April 1960 X-20 configuration, a double wedge upper surface and flat lower surface with rounded leading edges, was chosen for good hypersonic characteristics and easier manufacturing. This design would have required foldout fins for good low-speed stability. To eliminate foldout fins, the upper surface was tailored to maintain good hypersonic characteristics and improve low-speed stability. Modification of the upper wing surface, however, resulted in directional instability at small angles of side-slip at transonic speeds and an increase of 30,000 inch-pounds in elevon hinge moment at low supersonic speeds.

A wind tunnel program at subsonic through supersonic speeds to evaluate modifications required to correct these deficiencies resulted in the addition of the aft body ramp shown in Figure 3.



Figure 3



The ramp caused a noseup pitching moment which reduced the elevon angle required for trim, thereby reducing the hinge moments as shown. The static directional instability was eliminated by the influence of the ramp on the upper wing separation vortex. A favorable pressure field was formed so that the adverse interference effect of the vortex on the vertical tails was reduced and stability was restored.

Another example of an aerodynamic interaction was the gap between the vertical fin and the elevon. The aeroelastic and thermoelastic analyses showed a requirement for a large clearance at the outer end of the elevon. The resulting gap was found to cause low-speed, low-attitude pitchup if it was too large. Tailoring provided proper clearance without sacrificing low-speed stability.

These two examples demonstrate the iterative process involving analysis and test which are required to achieve a satisfactory configuration.

### X-20 Hypersonic Aerodynamics

Before the X-20 program, hypersonic aerodynamic data had been derived primarily from ballistic missile programs using blunt, nonlifting entry bodies. The X-20 glider was the first slender, lifting, entry vehicle designed for intensive exploration of the hypersonic flight regime.

#### AXIAL FORCE CORRELATION

X-20 aerodynamic wind tunnel test data of axial force coefficients at hypersonic speeds were not easily compared with analytical predictions because there was considerable scatter in

the test data and because it was difficult to predict skin friction which is a large contributor to the total axial forces. An analytical method for predicting skin friction was developed which utilized heat transfer data from theory and wind tunnel test. An extensive data correlation study of several wind tunnel tests showed that, for a given  $\alpha$ , axial force coefficient varied approximately linearly with a correlation parameter relating Mach number and Reynolds number in the form  $M/\sqrt{Re_x}$  as shown in Figure 4.

The analytical method was used to extend aerodynamic data to Mach numbers and Reynolds numbers other than those tested. Since wind tunnel test conditions do not match flight temperatures and velocities, the analytical method was also used to correct wind tunnel data to full-scale flight conditions.

#### PREDICTION OF HYPERSONIC LIFT

Hypersonic lift coefficients for the X-20 glider were predicted by combining analytically determined normal force and axial force coefficients. Normal force is dependent primarily on surface pressures and was found by integrating local surface pressures over the various components of the glider. Several methods were used to derive local pressure coefficients which depended on Mach number and surface inclination. These include modified Newtonian theory, hypersonic small disturbance theory, Prandtl-Meyer expansion, and tangent-cone theory. Skin friction was estimated as described above.

Figure 4 shows a typical analytical estimate of lift at Mach 22 as a function of angle of attack. Wind tunnel data points obtained in the Boeing Hotshot Tunnel show consistent agreement with this analytical prediction.

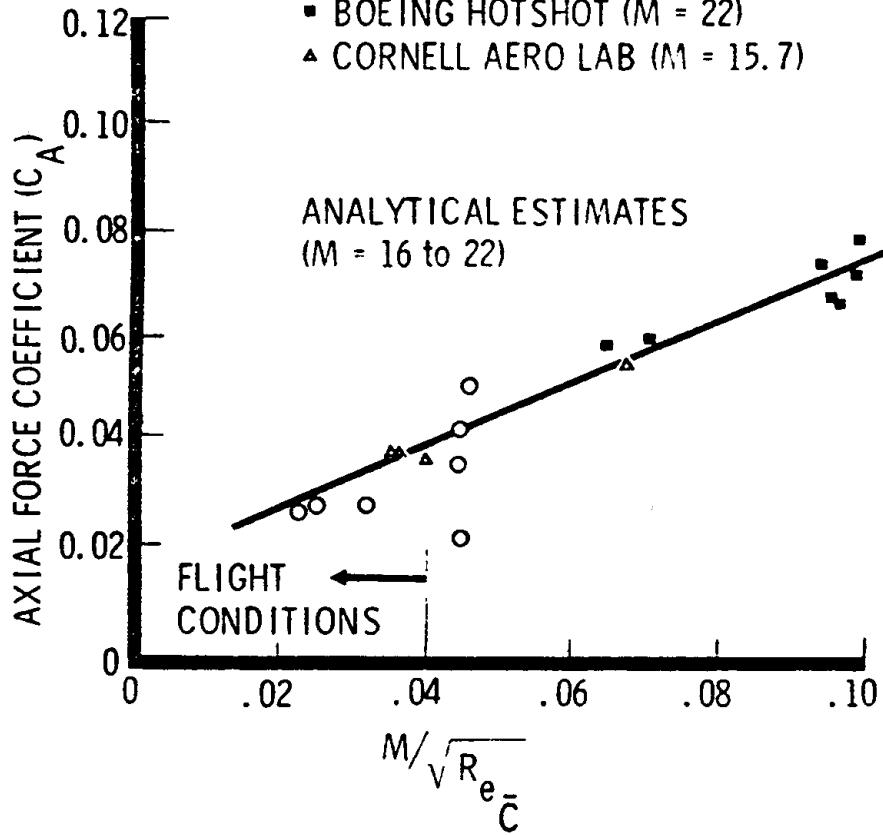


### AXIAL FORCE CORRELATION

$$\alpha = 15^\circ$$

- BOEING HOTSHOT (M = 16)
- BOEING HOTSHOT (M = 22)
- ▲ CORNELL AERO LAB (M = 15.7)

ANALYTICAL ESTIMATES  
(M = 16 to 22)



### PREDICTION OF LIFT

- BOEING HOTSHOT (M = 22)

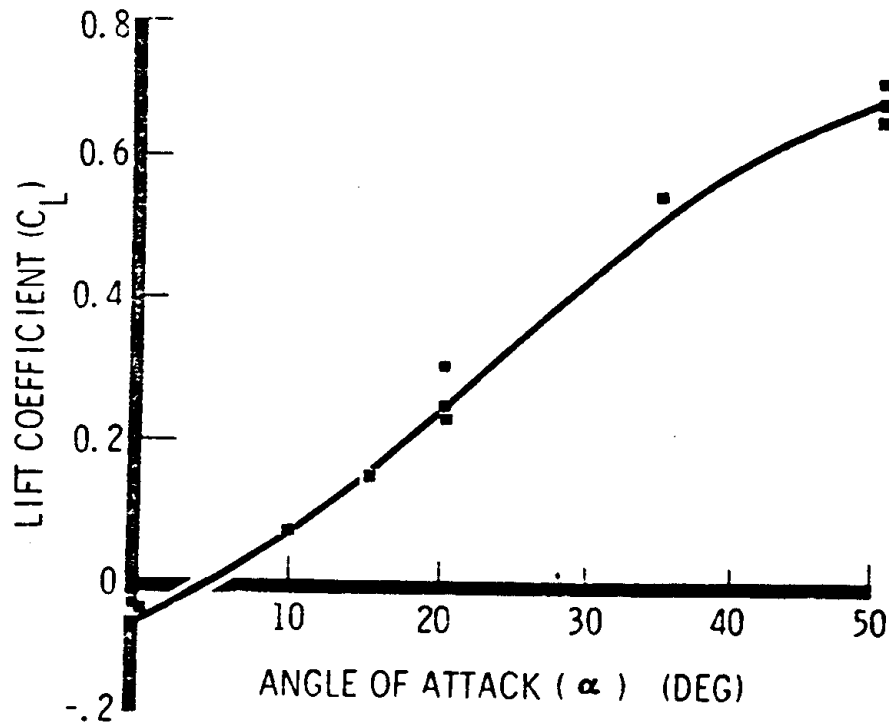


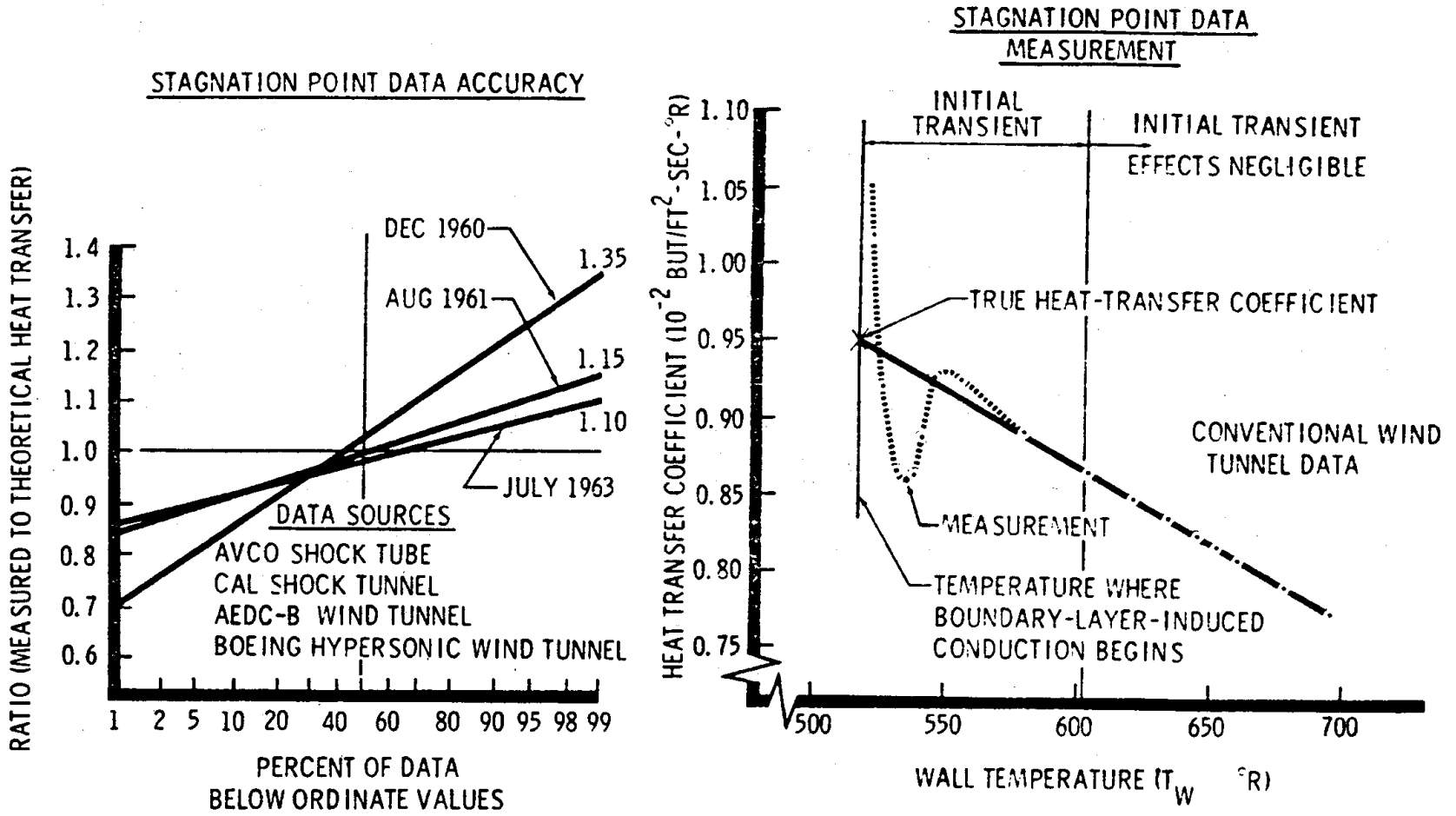
Figure 4

Laminar Theory and Data Improvement

The X-20 studies indicated that laminar heating rate theories based on exact, real-gas boundary layer solutions are accurate for simple shapes. Experimental support for this conclusion is given in the left figure in Figure 5. The curves shown on this figure are the actual wind tunnel test data that have been normalized. A value of 1.0 indicates exact agreement of theory and experiment. The nonlinear abscissa is graduated so that the normal distribution of random errors plots as a straight line, the slope of the line indicating the scatter of the data. In this figure, lines have been faired through actual data. The scatter in the laminar stagnation point data has been reduced by a factor of 3.5. The corresponding change in mean value (indicated by the value of the faired lines at the 50th percentile) has shifted only a few percent, indicating that scatter in the data are due to random experimental errors, rather than systematic variations. Since the stagnation point flow equations are basically identical to all laminar flow equations, this curve tends to confirm all laminar heating rate theory.

The reduction in scatter supporting the above conclusions is partially due to an improved method of data reduction developed by Boeing. Much of the scatter in conventional wind tunnel data is due to heat conduction effects; one type due to initial transients and the second due to aerodynamic heating. The effects of aerodynamic heating can be shown to increase consistently with time. As shown by the right hand figure in Figure 5, the consistent effect of aerodynamic heating is apparent in the data after the initial transients have disappeared. Extrapolation of this trend back to the initial model temperature yields the true heat transfer rate, unaffected by conduction errors. The application of this method has reduced the scatter in laminar stagnation point data taken in Arnold Center Tunnel B from 16 percent to less than 5 percent.

Figure 5



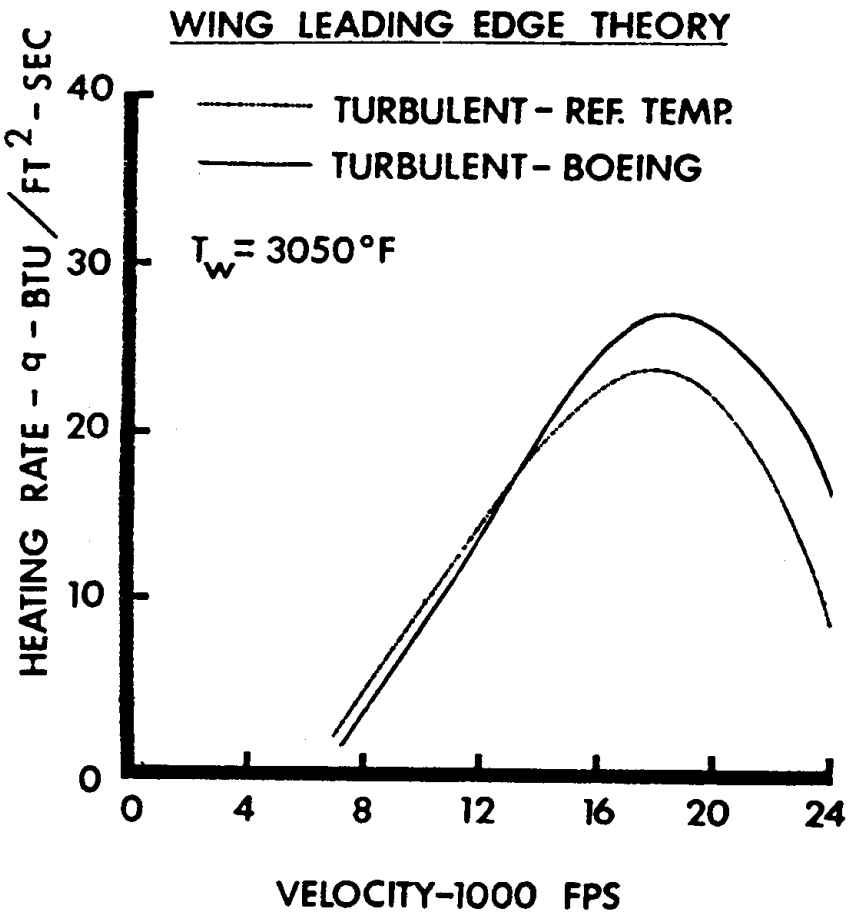
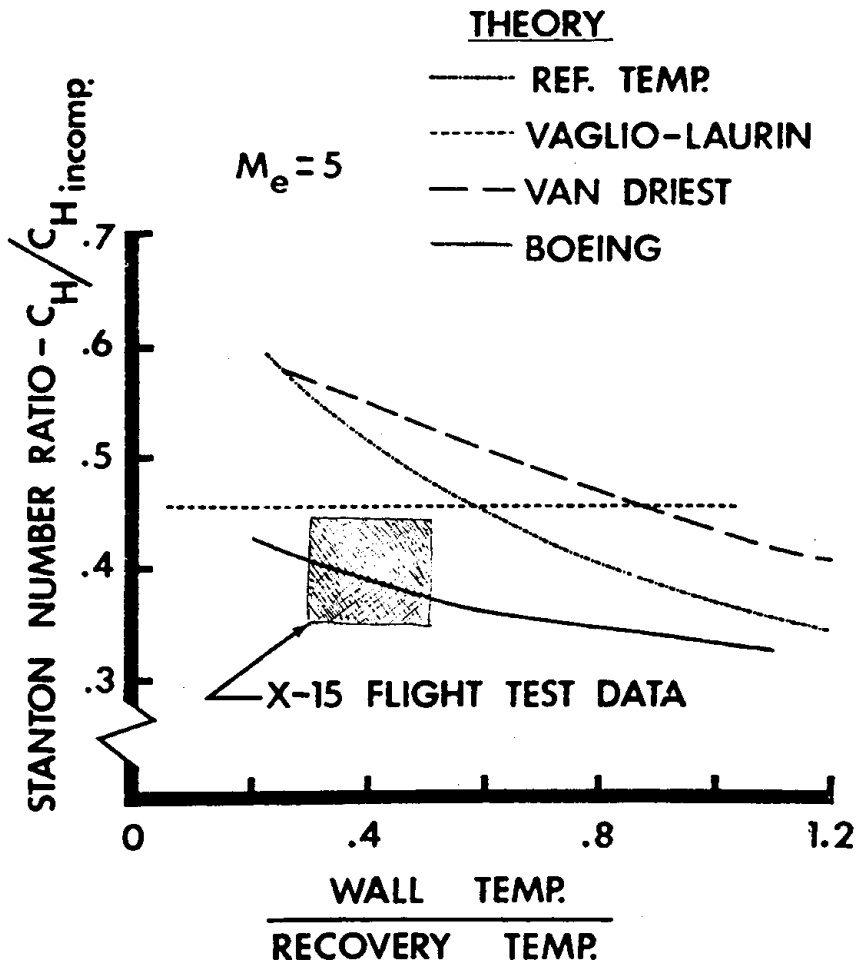
### Turbulent Heat Transfer

True simulation of the hypersonic entry environment cannot be accomplished in conventional ground test facilities. The complex flow associated with maneuverable lifting entry vehicles requires extensive theoretical knowledge. Since there has never been a rigorous turbulent theory, a major effort was made to improve turbulent flow analysis. Early in the X-20 program, turbulent heating rate analyses were based on an essentially empirical ideal-gas reference temperature method. This approach was substantiated by wind tunnel data available at that time and by limited shock tube data with dissociation levels as high as 30 percent.

Later, a new turbulent heating rate method was devised by R. A. Hanks of The Boeing Company, using exact laminar boundary layer theory as a starting point. The new method, when compared to other methods, predicted nearly the same heating rates for conditions ordinarily available in ground facilities, but significant differences were predicted for actual flight conditions. These predictions were confirmed by the data taken in the X-15 program, as shown in the graph on the left of Figure 6. On the basis of the X-15 data, the conclusion might be drawn that the other methods are, in general, conservative. This conclusion is, however, not supported by the new method, as illustrated in the right-hand graph. Here, the new method is compared with the earlier empirical ideal-gas reference temperature method. At the higher X-20 velocities the results of the empirical method are lower with respect to those of the new method, rather than higher as in the X-15 regime. Significantly, the velocity range in which the two methods are in near agreement is typical of the shock tube data which provided the major justification of the empirical method. These examples illustrate the caution with which empirical methods must be used, as well as the consequences of incomplete simulation.



Figure 6



### Design Detail Heating

The successful design of a maneuverable lifting entry vehicle requires careful attention to detail heating. Excessive heat at almost any location could result in loss of the entire vehicle, especially since local partial failure (such as panel crack) might lead to further heating rate increases. Figure 7 shows examples where this attention paid off.\*

1. Manufacturing tolerances and fabrication techniques cause some roughness: thermal expansion requirements at high temperatures also cause surface roughness in the form of laps, joints, and waves. Small surface waves, which were planned at one time for use on the X-20 to control thermal buckling, were found to cause large local heating rate increases, even when very shallow and highly swept. As shown, increases of 50 percent occurred on a typical test model.

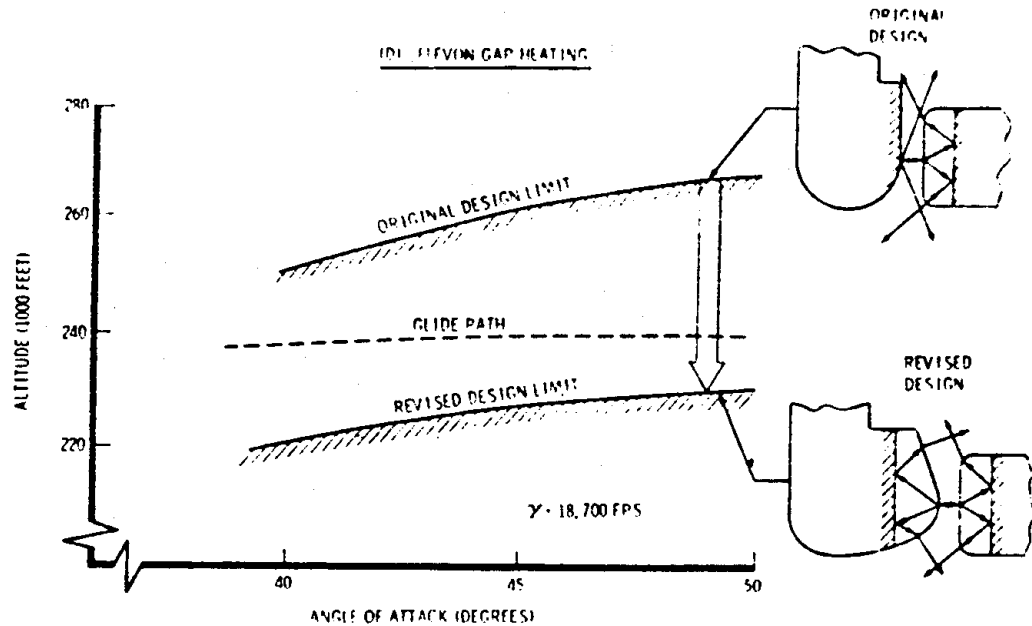
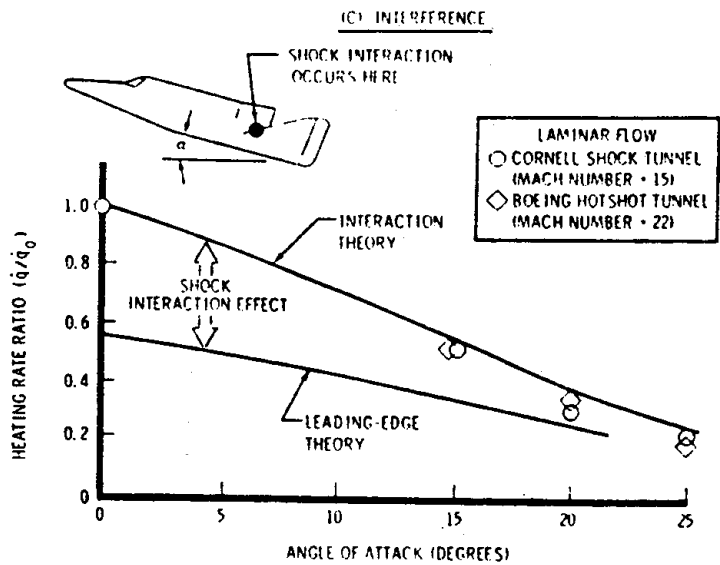
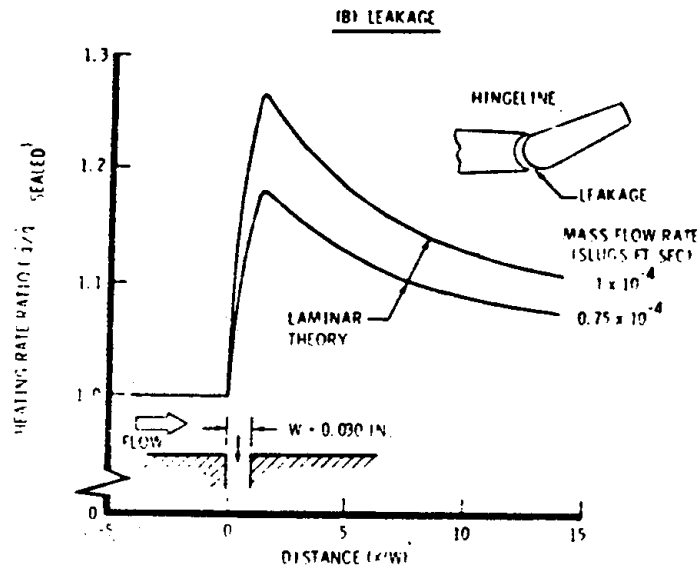
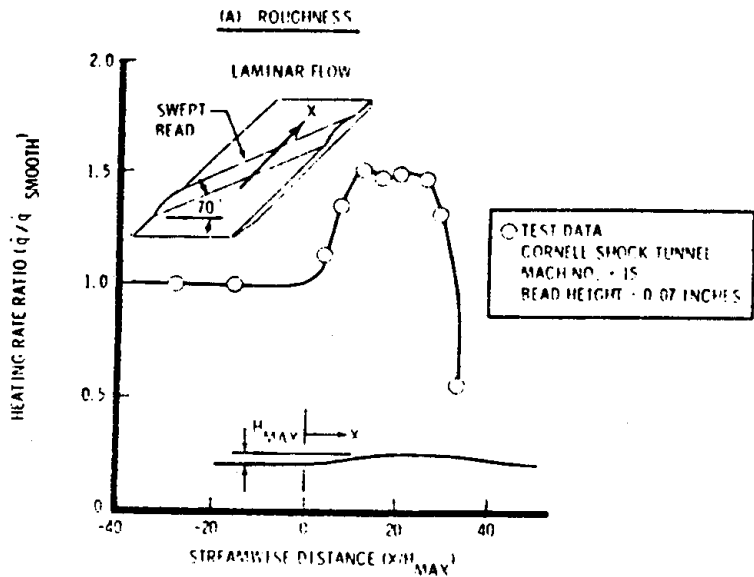
2. Inward leakage has adverse effects on both external heating rates and internal temperatures. Typical resulting increases in heating are illustrated in Figure B. Leakage must be controlled or eliminated in areas of relatively high local pressures and heating rates. Such areas of the X-20 include expansion joints between leading edge and lower surface panels, control surface hinge lines, and landing gear doors; leakage control was affected by continuous insulation beneath panels, control of gap dimensions, or physical seals as required.

3. The X-20 fin was placed entirely above the wing with the leading edges highly swept to eliminate interference heating. Fin heating rates did not seriously restrict performance of the X-20. There was still a pronounced interference heating effect. Vertical

---

\*Available data from the Space Shuttle's own flight testing phase indicates that the X-20 would have had no thermal problems during even a high crossrange reentry; naturally, Boeing cannot be faulted for having taken a cautious and (in retrospect) overly conservative approach given the limited data available on structures and reentry heating in the early 1960s.

Figure 7



fin laminar heating rates are much greater at low angles of attack than predicted by theory, due to the shock wave generated by the wing interacting with the flow field surrounding the fin. For this case, it was possible to develop a theoretical laminar method to predict the increases.

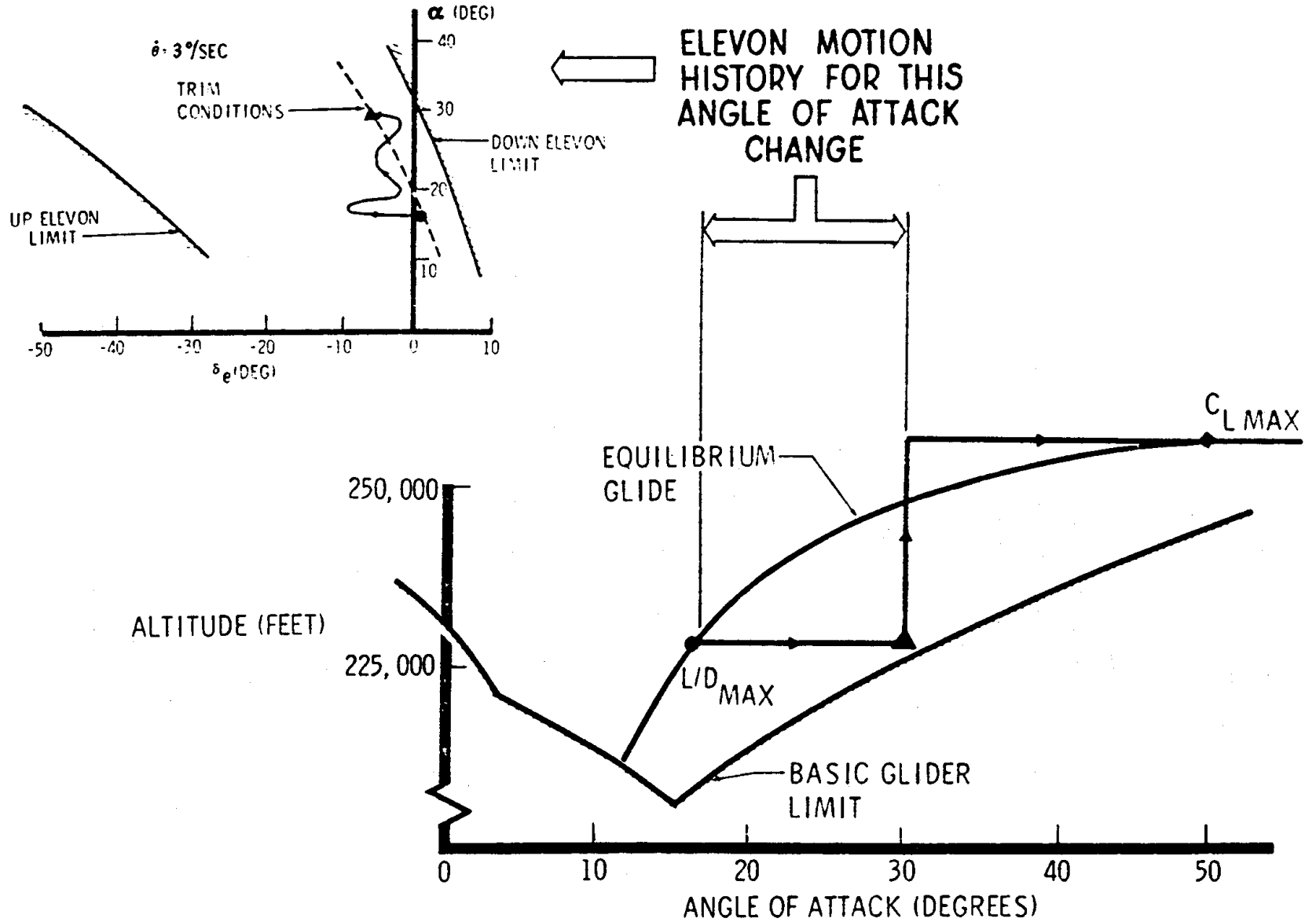
4. On the X-20, the region between the fin and elevon became a critical heating problem, not because of high heating rates but because of a very low "view factor" available for radiation of the convected heat. As shown in the figure, the initial design of the fin-elevon region was such as to cause the gap region to be critical above the glide line of the X-20. This condition was corrected by redesigning the fin and the elevon to provide internal radiation relief.

#### Hypersonic Maneuver Capability

Figure 8 illustrates maneuver limits, maneuver capabilities, and piloting techniques developed for the X-20 glider. Wing-level equilibrium glide altitudes are shown in relation to the minimum flight altitude as restricted by glider temperature limits. The insert shows elevon deflections required in relation to elevon deflection limits for a typical attitude maneuver. Both temperature limits vary with angle of attack.

It should be noted that the basic glider limits (altitude vs. angle of attack) are displayed on the energy-management display indicator which shows the pilot the proximity of the glider to the temperature limit. Not all limits like elevon and rudder deflection limits can be displayed. Therefore, maneuver requirements, capabilities, and limits must be carefully evaluated. The display is a useful aid, along with rate of climb indicator, in damping altitude oscillations, maneuvering, and establishing equilibrium glide.

Figure 8



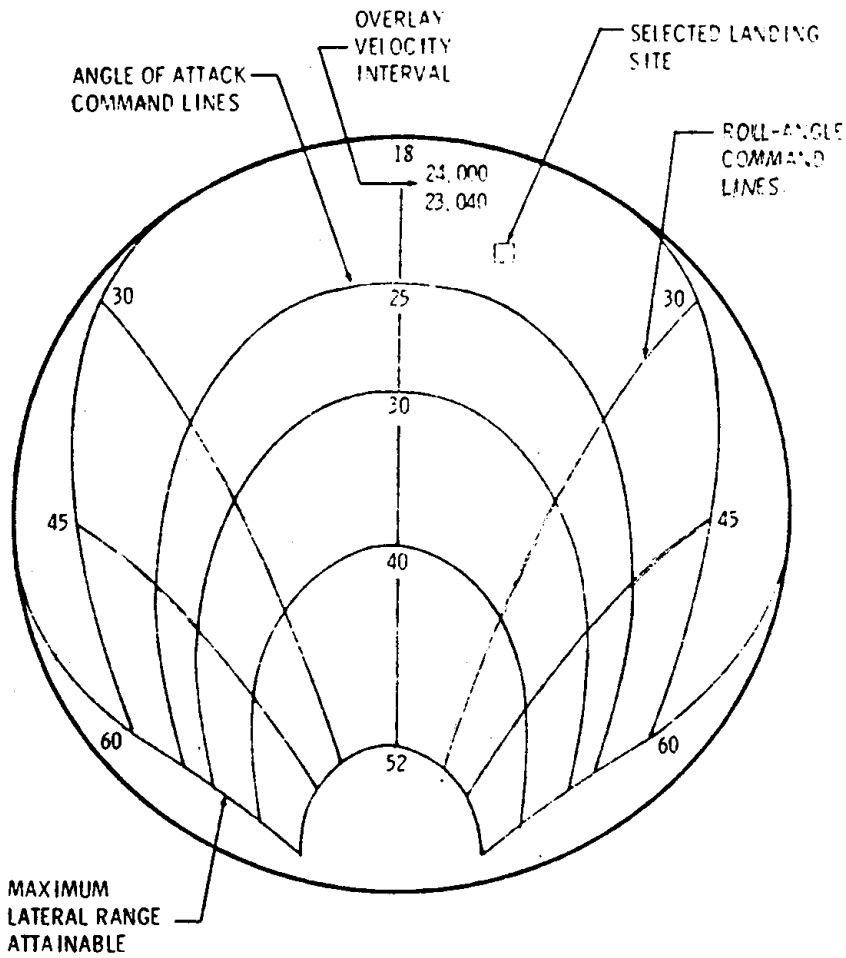
At a particular glide condition, like L/D maximum in the figure, attitude maneuver capability is limited by heating. The pilot cannot maneuver directly to the angle of attack for  $C_{L_{max}}$  for example, but must go to an intermediate angle of attack and wait for the altitude to change before completing the maneuver as shown. The maneuver can be accomplished with minimum overshoot or oscillation by selecting an intermediate angle of attack that corresponds to approximately 50 percent of the desired altitude change.

Also, surface deflection limits must be considered in maneuvers at any given altitude. In the example shown by the inset, the pilot was asked to pitch at approximately three degrees per second from the  $L/D_{max}$  condition to the angle-of-attack limit. The resulting elevon deflection shows that limits were not exceeded. For any normal maneuvering no problems were encountered, hence no surface limiting was employed. This X-20 experience indicates that, should elevon heating have become critical, a simple pitch rate limiter should be adequate for protecting the elevon from thermal damage.

#### Energy Management Display Indicator

The Energy Management Display Indicator (EMDI) is a special display developed on the X-20 program to enable the pilot to stay within structural thermal limits of the vehicle, reach the desired landing site, and attain the desired test conditions. Since these are concurrent tasks, two sets of information appear on a single display. The display is a 4-inch cathode ray tube with a set of transparent overlays which advance automatically during flight as a function of velocity. The EMDI has been evaluated in the flight simulator by the X-20 consultant pilot group. It is shown in Figure 9.

# ENERGY MANAGEMENT OVERLAY



# FLIGHT INTEGRATOR OVERLAY

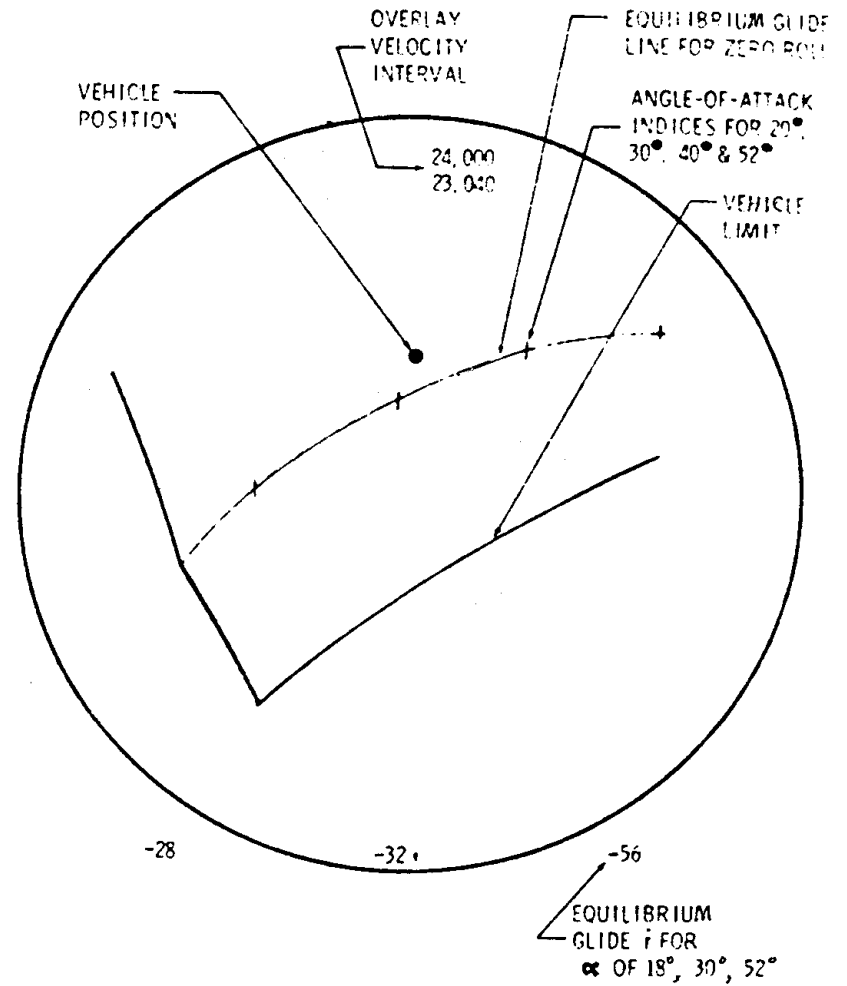


Figure 9

The Flight Integrator Display shows vehicle proximity to structural limits and establishes equilibrium glide and test conditions. Lateral motion of the spot reflects changes in glider angle of attack and vertical motion reflects changes in density altitude which are computed in the glider guidance computer. To obtain density altitude, the inertial altitude is corrected by using aerodynamic acceleration measurements within the computer altitude stabilization loop.

The Energy Management Display directs the pilot to a landing site and shows the glider's capability for test maneuvers enroute. This display avoids the requirement for large onboard computer by graphically displaying range capability on precomputed footprint overlays. The selected landing site is driven laterally and vertically as a function of crossrange and downrange. The overlay footprints show required angles of attack and roll that, if held constant, will just get the glider to the landing site. The pilot would normally overfly the command in order to center the landing site within his range capability.

#### Adaptive Gain Computer Performance

The X-20 was designed to operate within a broad flight envelope. The flight control system had to perform inside and outside the sensible atmosphere and with two aerodynamically different configurations (glider and abort).

Four control modes, three manual, and one automatic were provided. Normal operation was manual with the loop gain adjusted by the adaptive gain computer. At pilot option, the gain could be switched to one of three preselected fixed values. A manual direct mode, with control actuation bypassing the stability augmentation system, was provided for ultimate emergency.



Reliability was provided through major component rather than axis redundancy. Mean time between failures of the type that could cause switchover from the augmented mode to a manual direct mode is estimated to exceed 50,000 hours for the system.

Uniform handling qualities were provided by "shaping" the pilot's commands with a model and forcing the vehicle to follow the model output through the use of a high forward-loop gain. The gain computer was designed to sense the control surface limit cycle which occurred at critical gain, and to reduce the gain when the amplitude of this oscillation exceeded some small prescribed value. Pilot inputs and atmospheric turbulence both had frequency components within the spectrum of the gain changer filter and degraded the performance as shown. Both the pilot input and the atmospheric turbulence spectrum had their strongest frequency components at a frequency slightly lower than the limit cycle frequency. Thus it was possible to introduce an "up logic" circuit which had a lower authority and frequency bandwidth. This filter output was mechanized to drive the loop gain up. Gain holding qualities and the control response was vastly improved in the presence of pilot inputs and atmosphere turbulence.

#### Piloted Boost Simulation

Boeing was given a supplemental contract to the X-20 program to study pilot control during boost.

The study was completed in December 1962. The Titan III/X-20 air vehicle was used in a 6-degree-of-freedom fixed-base simulation. Approximately 100 flights were made using X-20 consultant Air Force pilots. A fixed-base simulation was used because results from a dynamic simulation of the X-20 boost problem on the Johnsville Centrifuge showed no significant effect on pilot performance because of the combined acceleration, pressure suit, and boost vibration environment.

The results of the fixed-base study showed that the pilot could successfully fly the boost trajectory, stay within limit constraints as defined by load, staging and malfunction detection system limits, and achieve system performance objectives. Stability augmentation was required.

### Structures and Materials

The X-20 program provided sufficient research and development in structures, materials, and manufacturing processes to allow design and fabrication of a manned glide entry system. Significant advancements were made in:

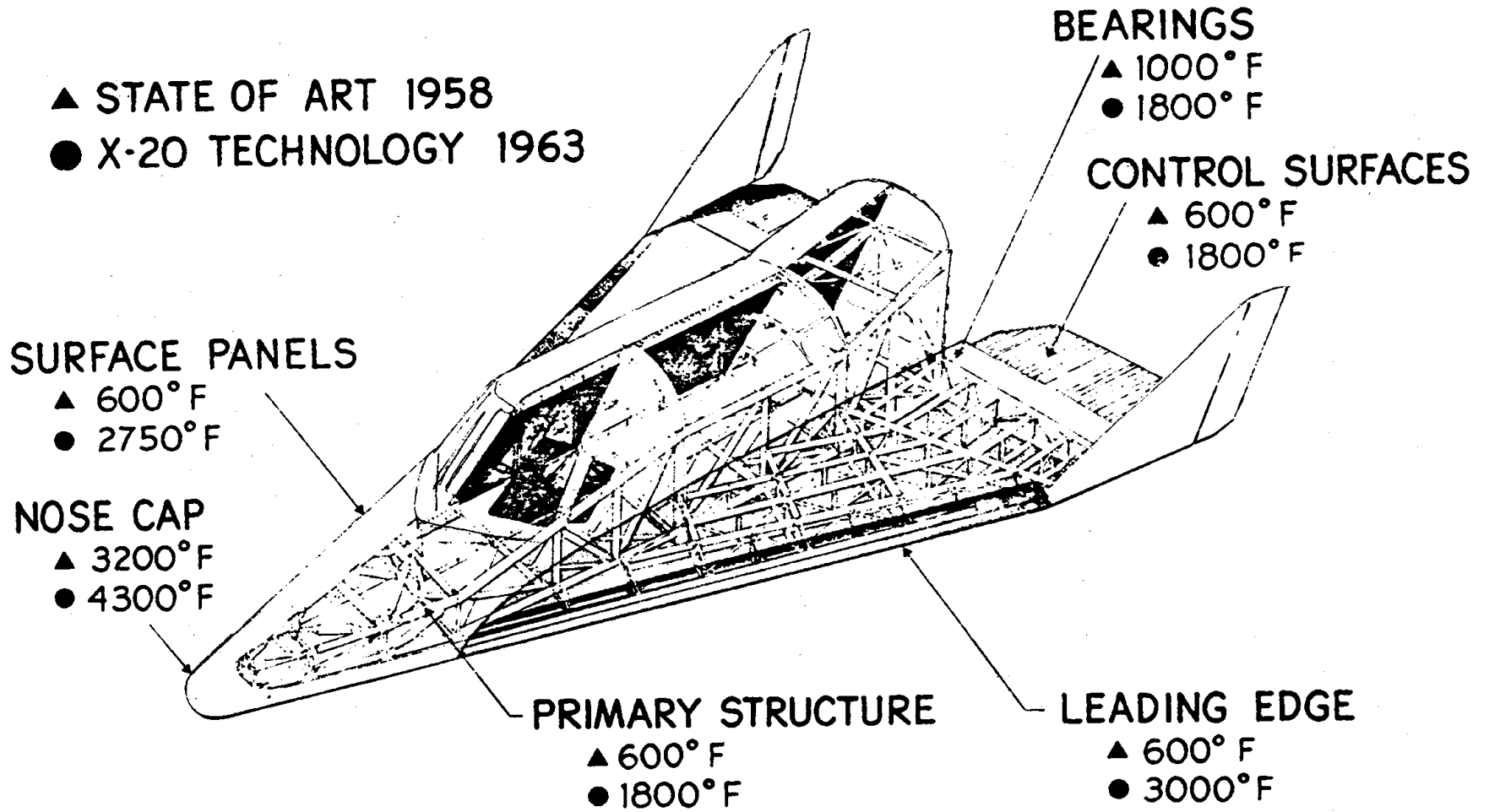
- Superalloy components:
- Refractory alloy components:
- Ceramic alloy components:
- High-temperature bearings:
- High-temperature thermal insulations:
- Test techniques and miscellaneous developments.

### Structural Component Advancement

The X-20 thermal environment demanded a structure capable of operating at temperatures well beyond the capability of production materials available in 1958. A pinned and fixed-joint truss was selected as the primary structure. This concept minimized the effect of thermal expansion stresses, and is shown in Figure 10.

Conventional structural materials such as aluminum, titanium, and stainless steel which could operate at temperatures up to 600°F have been replaced by a nickel superalloy, Rene' 41, originally developed for jet engines. This alloy has allowed extension of the maximum temperature tolerance of primary structural components to

Figure 10



1800°F. Surface skin panels have been developed to accommodate a temperature of 2750°F. A D-36 columbium alloy heat shield with a Boeing-developed, oxidation-resistant coating and a silica-fiber insulation was developed to thermally protect the primary load-carrying Rene' 41 substructure. An extensive materials, design, fabrication, and development test program led to two structurally different zirconia nose cap components, each of which were successfully ground tested to the design environment. Similarly, TZM molybdenum alloy was sufficiently developed and tested to allow leading-edge component fabrication for use up to 3000°F. New processing, fabrication, and inspection techniques required for these new materials were also developed. A major effort involved qualification of materials and components, such as window materials, for use at 2000°F, thermal insulations to 3000°F, and antifriction bearings to 1800°F. Thus, the materials and structural component state of the art was significantly advanced during the X-20 program.

#### Rene' 41 Hot Structure

At the advent of the X-20 it was apparent that conventional aircraft structural materials would not meet the design thermal environment imposed by lifting entry. Attention was immediately focused on the nickel and cobalt superalloys which retained significant strength properties at elevated temperatures. Rene' 41 was selected as the most efficient material available, and design-allowable mechanical properties, processing, and fabrication techniques have been developed for it.

Designs of efficient, minimum-weight structural members have been developed through the use of such processes as swaging of tubes, chem milling reinforcements, and fusion and resistance welding of assemblies. Heat treatment processes have been optimized and defined to obtain the best strength and ductility

properties over a wide temperature range. Both welded and bolted joints have been developed for truss members and have been used separately or in combination, depending on deflection-induced stresses.

These developments currently allow the design and production of aircraft-quality primary structural components capable of efficient performance at temperatures up to 1800°F.

### Control Surfaces

Relatively thin control surfaces make a determinate truss structure inefficient and impractical for this application. Therefore, a semimonocoque structure, capable of accommodating thermal gradients, was developed for the X-20. Design, fabrication and testing to simulated entry conditions was accomplished on a two-cell Rene' 41 corrugated web box. Testing demonstrated the feasibility of using a multicell torque-box hot structure for control surfaces.

The X-20 elevon, a three-cell torque box as released for production, is currently being fabricated and will be load and heat tested to the elevon design environment under an X-20 continuation contract.

### Landing Gear

An energy absorption system capable of operating efficiently throughout the temperature range of 70 to 800°F was developed to production status during the X-20 program. Inconel was selected as the most suitable material from the standpoint of energy absorption capacity, stress-strain curve shape, elongation characteristics,

and strength properties. This material exhibits large, plastic strain characteristics of a uniform nature, and minor variation in mechanical properties over the required temperature range at strain rates up to 300 in./in./min. as shown in Figure 11. Landing impact energy is absorbed by plastic deformation of the strap. Complete design-allowable stress strain curves at various temperatures and strain rates have been developed for this material and are available for the design of energy absorption systems.

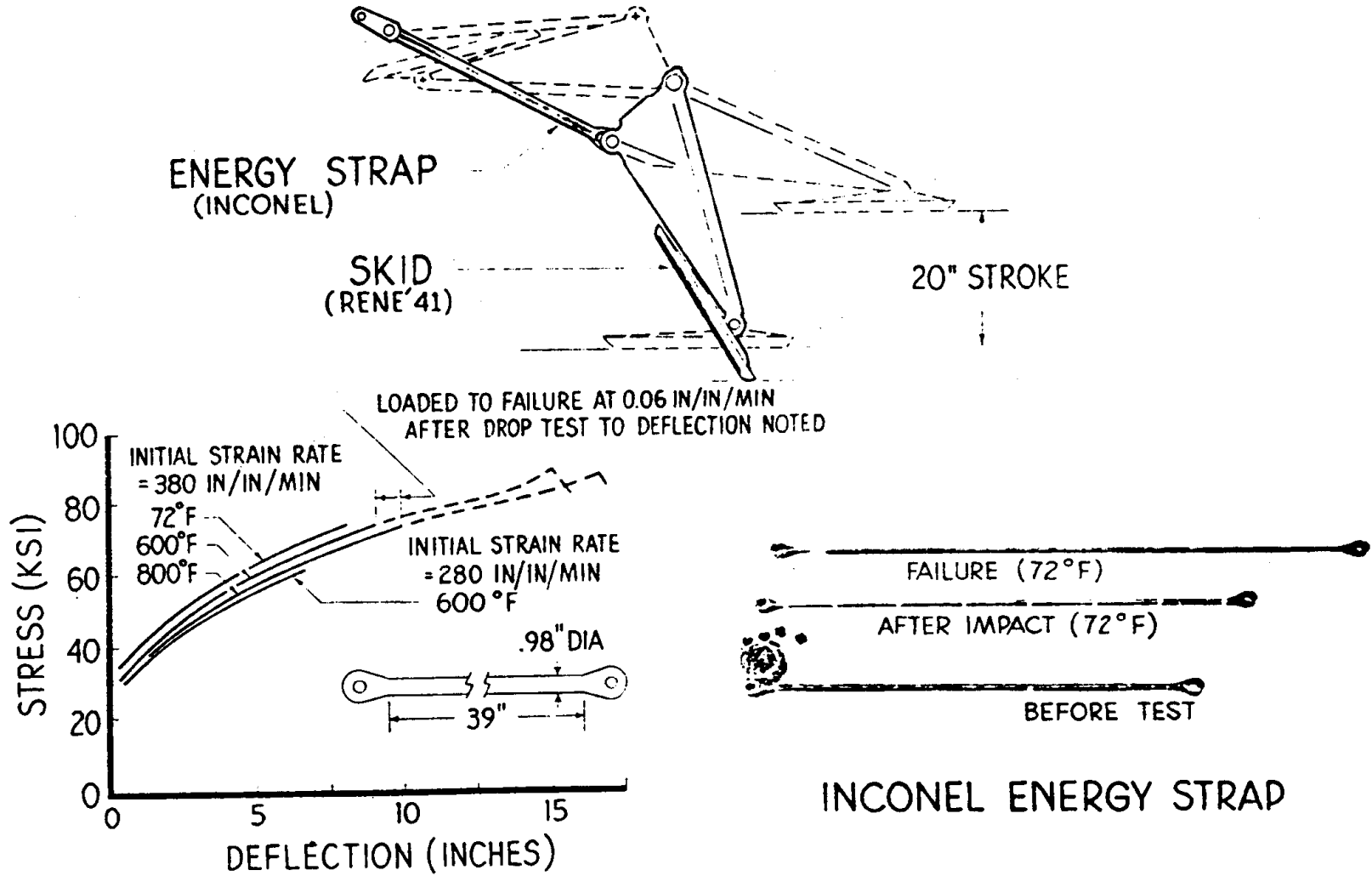
#### Insulated Surface Panels

The development of concepts for heat shields culminated in fabrication and testing of complete insulated panel assemblies. Columbian (D-36) heat shields using a standoff clip design were attached to the corrugated Rene' 41 load-carrying panel. An insulation layer of Q-felt provided the necessary temperature reduction to the Rene' 41 structure. The assembly was exposed to a combination of design sonic excitation and temperature as shown on the chart. Plasma jet testing of an assembly simulating the junction of four heat shields demonstrated adequate control of leakage. Additional testing performed under the X-20 continuation contract of a nine-tile panel assembly in evacuated conditions has shown that analytical prediction of internal temperatures are in excellent agreement with test results. The test sequence subjected this panel assembly to the equivalent of five entries. Field repairs of the coating using the Boeing-developed coating repair process was successfully demonstrated during this series of tests.

#### Leading Edge

Leading-edge components have been developed and successfully subjected to simulated boost and entry conditions. Concept development on the X-20 program centered around single- and double-shell designs, both of molybdenum alloy. Each concept was

Figure 11



developed to the stage where it successfully survived the equivalent of four complete boost and entry cycles of the X-20 flight regime. These tests not only verified the entry capability of the leading edge but also indicated multiple use capability.

Later material developments showed that slight additions of zirconium to the 0.5Ti-molybdenum alloy gave improved properties--particularly higher recrystallization temperatures. This new alloy, TZM, was used for all production-released molybdenum alloy hardware.

Integrated vehicle structural requirements, such as limitations on steps and gaps between leading edge segments, internal structural load deformations, fabrication tolerances, and material characteristics, indicated that the X-20 structural requirement best could be met by a simpler, although somewhat heavier structural concept. The revised concept consisted of a single TZM chemically milled shell. The chemical milling permitted use of integral stiffeners. The shell was supported by machined D36 (columbium) fittings.

#### Design Limits of Refractory Alloys

The design and development program also served to identify design limits of refractory alloys. There were, of course, the obvious design constraints associated with the necessity of applying a protective coating. The principal limitation on columbium alloys is the tendency to creep at high temperature, greatly reducing their load-carrying capability. Minimum gages (0.014-inch for molybdenum alloys and 0.012-inch for columbium alloys) were established to assure sufficient material for oxidation protection of the edges.

The room-temperature ductility of TZM, which is not very high in the bare material, is considerably reduced by the coating



process. This lowered ductility manifests itself in making fabrication and assembly of parts difficult and dictated extremely tight control of dimensional tolerances during coating. Programs under way at the time the X-20 was canceled indicated that controlled heat treatment could reduce the problem.

Thermal exposure (above 2000°F) recrystallizes TZM (and other molybdenum alloys), which in turn lowers the room-temperature ductility of the alloy. This can be seen at the bottom of the chart in terms of grain growth in the photos, and transition from ductile to brittle impact failures, as the material reaches 100-percent recrystallization. This required that the TZM components be designed as "brittle" materials through the landing phase.

#### Coating Processes and Refractory Alloy Components

The selection of refractory alloys was predicated on the development of a production process for application of oxidation resistant silicide coating. The fluidized bed technique was developed for this purpose. In this technique the parts to be coated are suspended in a bed of silicon powder that has been heated to the required reaction temperature. The silicon is made fluid by passing a mixture of argon and a reacting halide gas up through the bed. This facility not only gives a uniform coating, but is a rapid production method in that it eliminates the long heat-up and cool-down with associated retort-furnace methods. In addition to coating X-20 parts, the fluidized bed technique has been used to coat parts for the ASSET vehicle and to coat experimental rocket nozzles and thrust chambers.

Two production fluidized beds capable of coating parts 17 inches in diameter and up to 3 feet long were built and qualified for the X-20 program. Processes were developed for coating both

D-36 (columbium) and TZM (molybdenum) components. Although the coating temperatures and times varied for the two alloys, the basic techniques of cleaning, inspecting, and coating were the same. The cycle was split for most components, half the coating being applied to detailed parts before assembly and half after assembly. This procedure afforded protection of faying surfaces and ensured coating of areas where coating damage had occurred during assembly.

An important adjunct to the coating process was the development of emittance improvement coatings, applied over the silicide oxidation protective coating. A Synar-silicon carbide was used for D-36. Because of the low emittance of silicide-coated D-36, and the significant improvement obtained, the top coat was applied to all exterior D-36 surfaces. A similar technique was developed for TZM. Evaluation of this process is continuing under an X-20 continuation contract.

#### Entry Capability of Coated Refractory Alloys

The allowable time-temperature capability of coated refractory alloys when exposed to an X-20 type entry has been established through extensive testing and analysis. In these tests the critical parameters, temperature, pressure, and atmosphere composition were simulated. Numerous tests were conducted extending through and beyond the predicted design environment. Besides normal entry conditions depicted on the chart, the tests included evaluation of abort trajectories, simultaneous load oxidation tests, and parametric environmental tests. Analysis after exposure included extensive metallurgical evaluations of coating and base metal integrity.

These tests and analyses have provided a great deal of information about coating-metal and coating-environment reactions.

Models developed for predicting the nature and rate of these reactions have provided the basis for predicting the performance of coated refractories in environments that differ from the X-20 entry conditions. Allowable time-temperature curves similar to those shown in Figure 12 could be readily developed for other design trajectories.

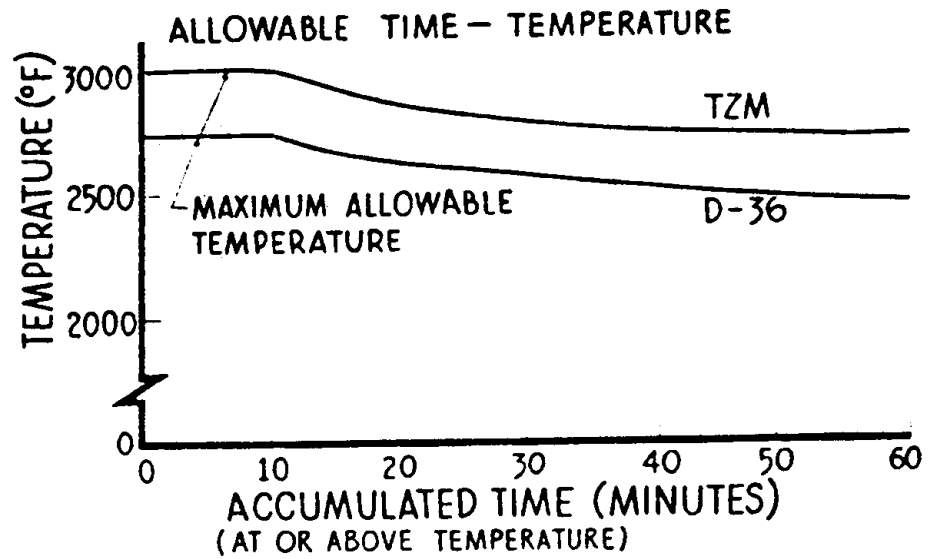
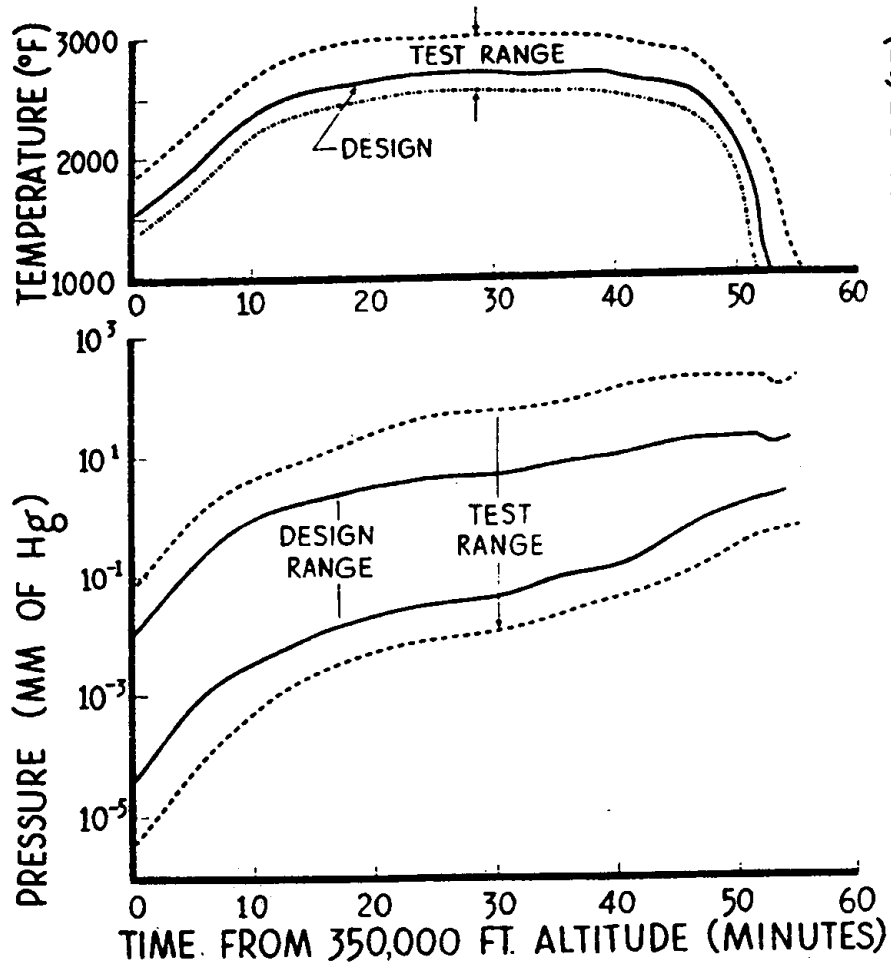
### Nose Cap

At the conceptual stage of X-20, the nose cap (shown in Figure 13) was determined to be one of the most crucial problem areas. For this reason two independent development programs were initiated. Both were successful. The primary design was the Ling-Temco-Vought cap and the backup design was the Boeing cap. The primary design was composed of a structural siliconized-graphite shell, protected by zirconia tiles held in place by zirconia pins. The pins and tiles were reinforced by platinum-rhodium wire so that the cracks would not cause total failure. The backup design was a monolithic structure composed of zirconia reinforced with platinum-rhodium wire in the form of shaped baskets. Hexagonally shaped tiles were induced in the outside surface in the forming process to allow for thermal expansion and act as crack stoppers. Attachment to the glider structure in both cases was similar. A forged molybdenum (TZM) ring with a clamping action was used. Molybdenum rivets, nuts, and bolts were developed for attaching the ring to the Rene' 41 truss assembly. Both caps contained flight-pressure ports and high-temperature thermocouples. Full-size nose caps were fabricated for testing because conventional scaling methods are not satisfactory for ceramic components.

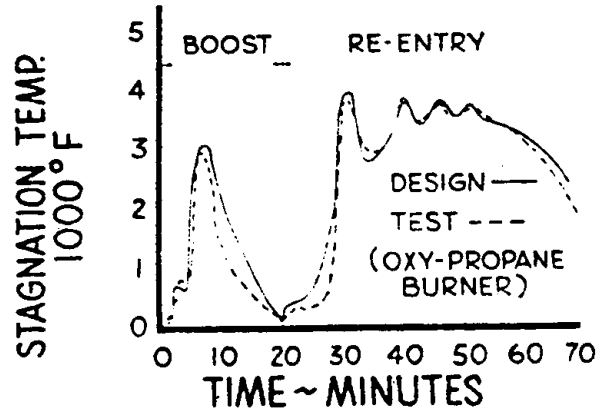
Both concepts were verification tested in plasma jet, ram jet, rocket exhaust, oxy-propane burner, and random noise facilities.



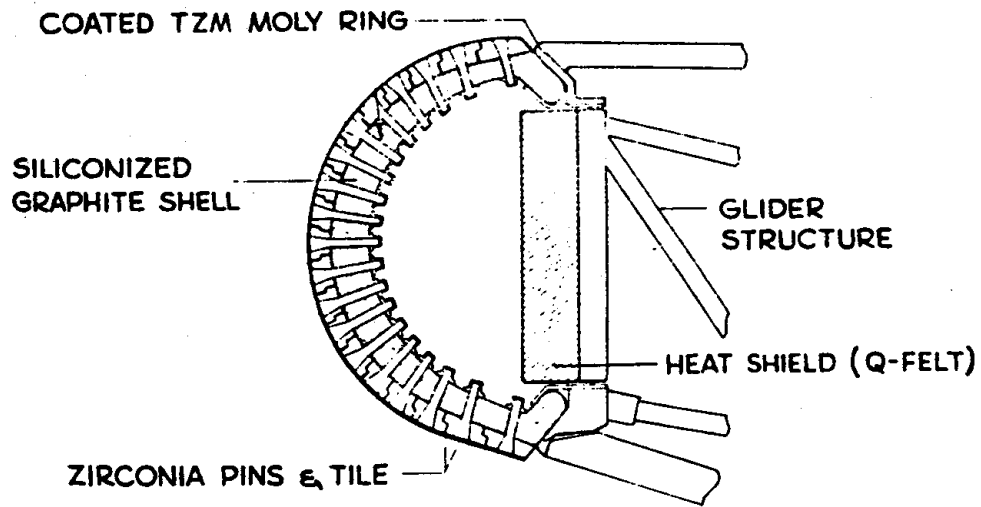
Figure 12



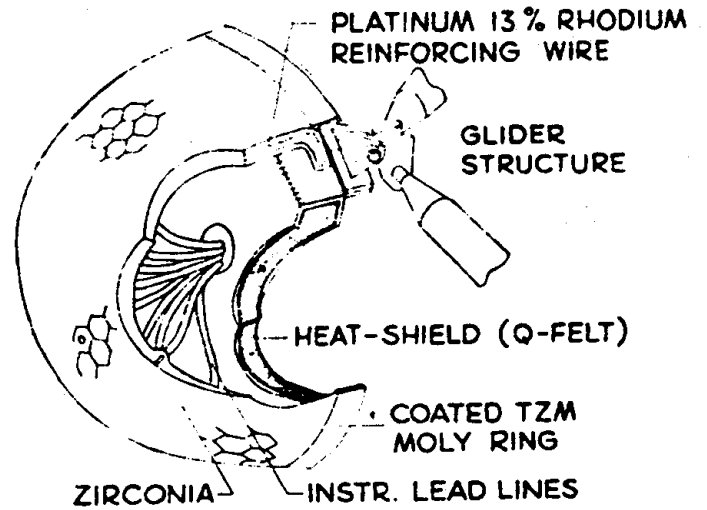




(LING TEMCO VOUGHT)



(THE BOEING COMPANY)



Simulation of all design points corresponding to the X-20 environment proved both nose caps adequate for flight. These tests further demonstrated that the design and fabrication methods used were satisfactory.

### High-Temperature Thermal Insulations

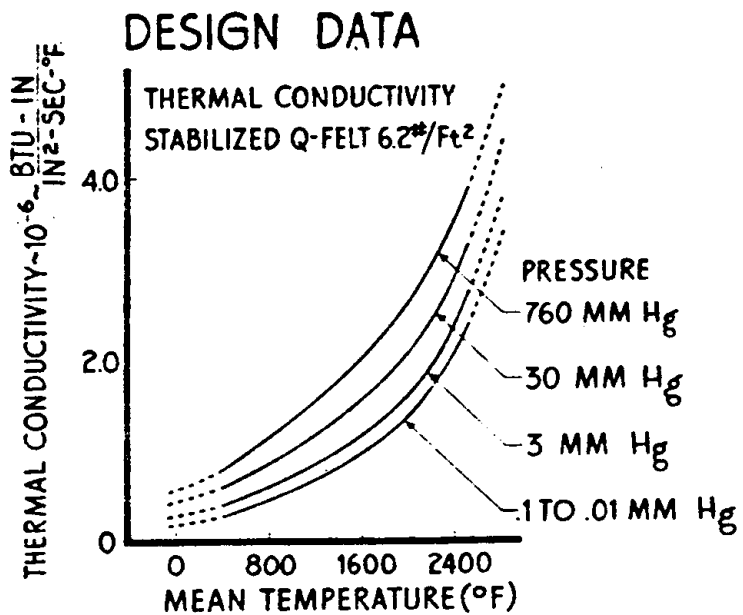
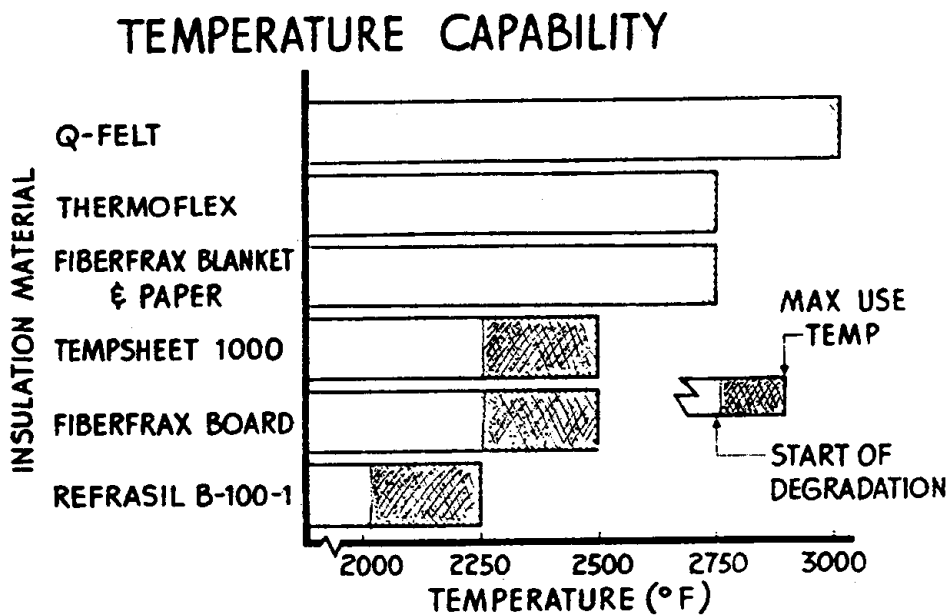
A two-way program was followed for development of thermal insulations for the X-20 program. Commercial fiber insulations were evaluated to determine if their use temperature could be extended beyond the 2000°F recommended by the manufacturers. Results of this program established the temperature limits of the insulations as shown. Laboratory techniques for production of alumina and zirconia fibers were scaled up in an attempt to produce a new high-temperature insulation. A pilot production facility was completed that successfully produced fibers having the desired temperature capability and conductivity. First attempts to put the fibers into a usable form showed promise, but the program was canceled when it was determined that commercial insulations would meet X-20 requirements.

Tests determined the upper temperature limit for nearly all commercial high-temperature insulations. The most significant of these tests was evaluation of shrinkage when the insulation was exposed to various temperatures up to 3000°F. Extreme shrinkage resulted at temperatures below 3000°F for all materials tested except for a quartz fiber known as Q-felt. A small dimensional change was observed by Q-felt at about 2000°F with no additional change to over 3000°F. It was therefore possible to stabilize this material by pre-exposure to 2000°F.

Figure 14 shows complete conductivity design data developed for the stabilized material up to its maximum use temperature.



Figure 14



### Other Structural Developments

Many other significant advances were made in structural subsystems, components, test techniques, design property data, measurement techniques, instrumentation development, fabrication techniques, and other detail design items.

High-temperature windows and window-mounting materials, window-mounting techniques, lightweight cryogenic tanks having superinsulation, and high-temperature antennas and wave guides will apply to future entry systems. High-temperature fastener development, high-temperature hydraulic fluids, instrumentation, high-temperature aerodynamic seals, and a multitude of other design detail items will also make important contributions.

Immediate benefits will result from use of design property data and measurement techniques developed. Techniques such as the use of an electron beam for heating zirconia to 4000°F to determine emittance values can be applied to the evaluation of other high-temperature materials. The mechanical and physical properties developed for Rene' 41, 2219 aluminum, coated refractory alloys, zirconia, fasteners, and insulations are also available.

### Landing Skids

The X-20 landing gear was a tricycle, metal-skid configuration able to survive the entry heating environment without thermal protection. The main skids were designed to generate a higher friction coefficient than the nose skid. The higher friction coefficient was required for the main skids to provide ground slide-out stability, especially at the lower speeds when aerodynamic forces are ineffective. The skids, designed for use on concrete, asphalt, and dry lake beds, were replaceable after each flight.

The main skids were a Goodyear design and were formed and welded of Waspaloy sheet metal with Rene' 41 wire bristles twisted over a series of longitudinal rods. Since the wire brush was inherently able to handle runway irregularities in the roll axis, the skid pivot attachment design allowed motion in the pitch axis only. The wire brush design gave a high friction coefficient with 5000 to 8000 feet of slide-out distance.

The nose skid was initially a Bendix design and was formed and riveted of inconel with tungsten carbide hard coat on the sole plate for wear. The final design, with the sole plate, was forged of Rene' 41. The skid-pivot attachment allowed pitch and roll of the skid over irregular surfaces and prevented yaw. A nose ramp allowed sliding over sharp bumps.

Skids were tested on the Holloman AFB rocket sled. The test sled could simulate landing impact and slide-out loads. Test surfaces were concrete and asphalt. The main skids were also tested at Edwards AFB with a modified X-15 skid-test trailer towed behind a B-47. Tests were at speeds up to 120 knots on lakebed and concrete runways. Figure 15 shows the skid test results.

#### Hydraulic Servoactuator

X-20 flight control required the use of control surfaces throughout entry. A hydraulic system was chosen for surface actuation to minimize development time and cost. Because the X-20 operated with temperatures above 1800°F during entry, the hydraulic system was designed to be cooled using the hydraulic fluid as the initial heat transport medium. Final heat rejection to the hydrogen heat sink was through the intermediate water-glycol cooling loop.



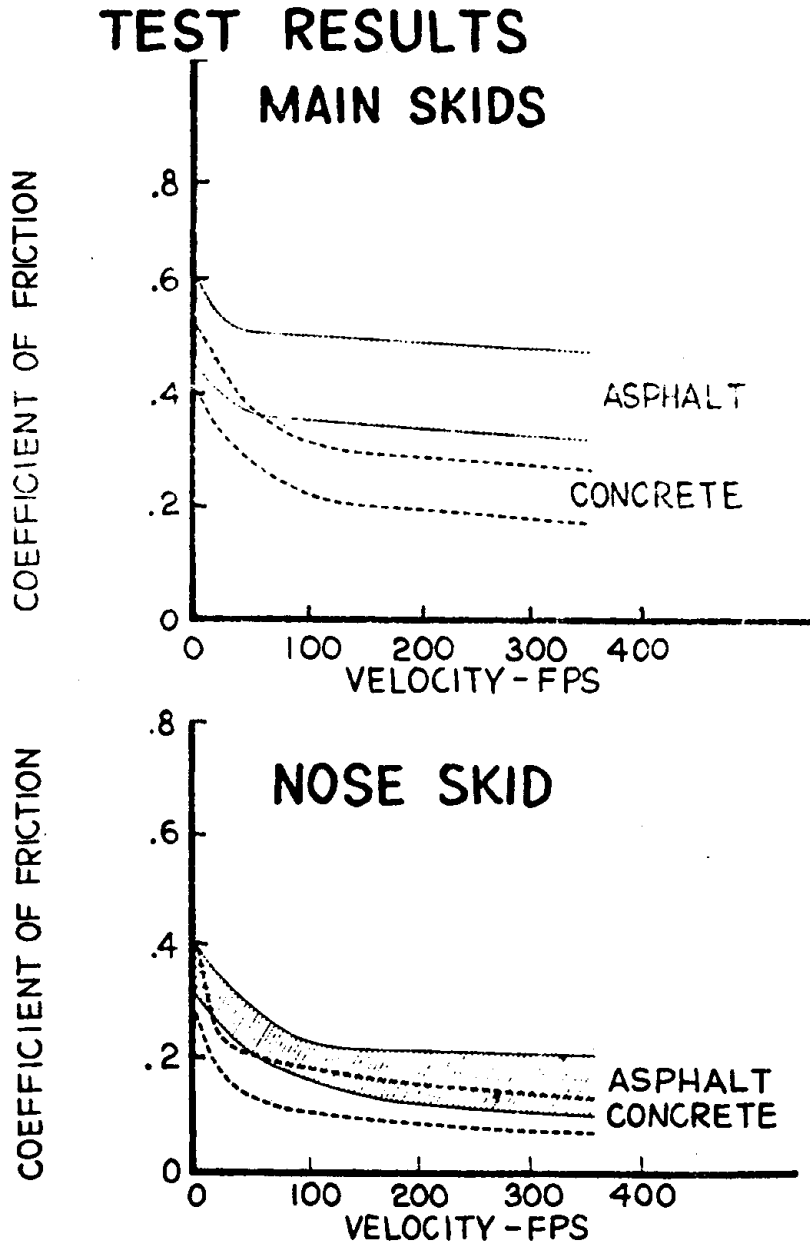


Figure 15

Landing Gear Skid Test Results

The 400°F hydraulic fluid operating temperature eliminated the need for a major advance in the state of the art in fluids, transducers, and servovalves. All hydraulic system components except surface actuators and associated plumbing were located in a cooled compartment to hold entry heat loads to a minimum. The surface actuators and plumbing exposed to high temperatures were insulated with a 1-inch "Q-Felt" blanket. The actuator and components were cooled by circulating return hydraulic fluid through the jacket and rod. The coolant flow required did not exceed that required for normal surface control; hence, there were no additional pumping loads. The dual rod seal was developed to provide high system reliability.

A prototype actuator including the insulation and cooling jacket was successfully tested through entry and altitude environment. These tests showed close agreement between predicted and measured temperatures at critical points throughout the actuator. The dual rod seal was successfully tested through a 100,000-cycle life test at fluid operating temperatures of 20°F to 550°F.

#### Water-Wall Development

One of the major X-20 accomplishments was the successful development of a water-wall to thermally isolate the pilot's compartment, equipment bay, and secondary power bay from entry-generated heat. The water-wall heat sink was a gel mixture of 95 percent water and 5 percent cyanogum 41 jelling agent contained in a series of wicks. The purpose of the gel-wicking arrangement was to maintain proper distribution of water in the panels under boost, space, and entry conditions.

The water-wall was of lightweight construction weighing approximately 0.14 psf empty. The panel thickness varied with the

water capacity and was approximately 0.31 inch for a water capacity of 1 psf. The outer insulation layer thickness was 0.5 to 0.75 inch depending on the application. The water-wall relief valves opened at approximately 0.5 psig. The water panel temperature increased from approximately 50°F at maximum altitude to 200°F at sea level as the evaporation temperature increased with atmospheric pressure.

Water panels of this type can be used on either radiant or ablative cooled entry systems. However, the X-20 did not require space storage so further development would be required to attain this feature.

#### Integrated Hydrogen Cooling and Power Generation System

The X-20 cooling and power system used cryogenic hydrogen for auxiliary power unit fuel and as a heat sink in controlling glider internal temperatures. The system consisted of the following major elements, and is shown in Figure 16.

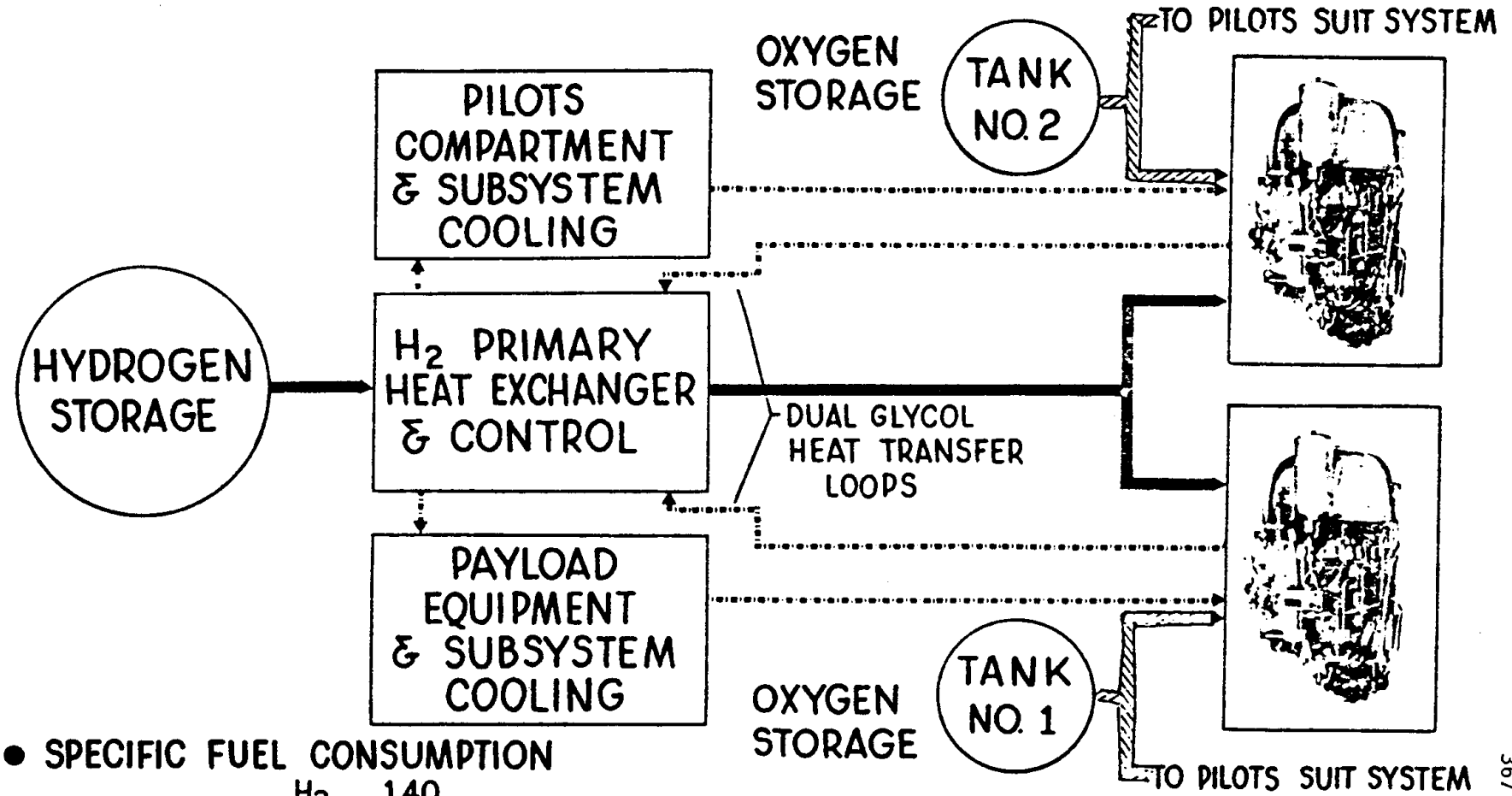
1. Tanks for storage of cryogenic hydrogen and oxygen.
2. A primary hydrogen/glycol-water heat exchanger.
3. Redundant glycol-water cooling loops to transfer heat from the cooled compartments, hydraulic fluid, alternators, and auxiliary power units to the primary cooler.
4. Related plumbing and controls.
5. Redundant auxiliary power units.

This system required the development of lightweight vacuum insulated plumbing and tanks as well as various system mechanical components. These developments are applicable to other cryogenic systems.





Figure 16



● **SPECIFIC FUEL CONSUMPTION**

H <sub>2</sub>	1.40	
O <sub>2</sub>	<u>.85</u>	
	2.25	LBS/HP·HR

● **SPECIFIC WT = 5 LBS/HP**

APU MFG: SUNDSTRAND AVIATION  
 H<sub>2</sub> HEAT BY CHANGER MFG: AIRESEARCH

The auxiliary power unit consisted of a unique hydrogen/oxygen powered, three-stage single disc turbine that drives hydraulic and electrical power generating equipment. The turbine uses a catalytic combustor and has a zero-g lubricating system. The hydraulic pumps were designed to operate at temperatures up to 400°F and delivered 8.5 gpm at 3000 psi. The 12-kva electric alternators were liquid cooled and were the first rotating electrical power source specifically designed for space use.

### Personnel Protection

To provide pilot protection in a potential vacuum environment and to meet other X-20 requirements, a new space suit was developed through the combined effort of USAF-ASD and the David Clark Company. The integrated suit assembly included gloves, helmet, boots, communication equipment, biosensors, ventilation, underwear with special joints, insulation, and restraint and parachute harness. The final suit configuration was the result of extensive testing in environmental chambers and flight simulators to evaluate suit growth, weight, back pressure, ventilation, mobility, and leak rate. This program resulted in a suit that can be pressurized to 5 psi and still exhibit good flexibility with minimum growth. It is also suitable for other space applications. The suit offered the following advantages over previous designs:

- Head moved within helmet, offering improved mobility and field of vision.
- Minimum helmet rise under pressure, eliminating tiedown straps.
- Excellent arm and leg mobility while seated at 5 psi pressure.
- Suit retained its external dimensions at 5 psi pressure, and shoulder width remained less than 25 inches.

### Crew Station and Side Arm Controller

The X-20 crew compartment was a welded aluminum structure pressurized to 7.35 psia. Specific design features in the crew station were: (1) high-temperature windshields for pilot vision, (2) provisions for full pressure suit operations and the associated reach problems, (3) an ejection seat positioned for boost, entry, and ejection conditions, (4) a side arm flight controller and rudder pedals, and (5) instrument displays to satisfy orbital flight, entry from orbit, maneuverability during hypersonic glide, and controlled, unpowered landing at a predetermined site.

The side arm flight controller was a two-axis unit having minimum cross coupling in roll and pitch, and minimum sensitivity to acceleration forces. The controller operated both reaction controls and control surfaces. The crew station arrangement and the side arm controller were developed through extensive simulation and piloted centrifuge programs in which Air Force and NASA astronauts participated. These programs included operation under pressurized suit conditions and pilot-in-the-booster-loop simulations.

Although this crew station was designed specifically for the X-20, the final arrangement can provide background data and design features applicable to future lifting entry vehicles.

### Boeing X-20 Continuation Program

Many hardware development tasks pursued as a part of the X-20 program represented substantial advances in the state of the art in a wide variety of technical areas. The same was true for many purely analytical development tasks. Because of their potential value in other programs, a number of these partially completed tasks were authorized to be completed. This effort was designated as the X-20 continuation program.

The following is a listing of the number of X-20 reports generated by Boeing and subcontractor organizations, followed by remaining continuation tasks and the expected dates of completion.

	QUANTITY
<u>BOEING DOCUMENTS</u>	<u>1255</u>
ENGINEERING	1050
WIND TUNNEL	155
FACILITIES	12
MANUFACTURING	19
PROGRAM MANAGEMENT	19
<u>SUBCONTRACTOR DOCUMENTS</u>	<u>1780</u>
AIRESEARCH	207
BELL	33
ELECTRO-MECHANICAL	344
LING-TEMCO-VOUGHT	129
MINNEAPOLIS-HONEYWELL	582
SUNSTRAND	240
THIOKOL	177
THOMPSON-RAMO-WOOLDRIDGE	23
WESTINGHOUSE	45
<u>TOTAL X-20 DOCUMENTS</u>	<u>3035</u>

NO.	ITEM	TASK	COMPLETION DATE
2-6	D36 EROSION SHIELD PANEL	TEST & EVALUATE	9-30-64
2-3	HIGH TEMPERATURE BEARINGS	DETERMINE LOAD/LIFE CHARACTERISTICS	5-31-65
----	L-T-V NOSE CAP	COMPLETE DEVELOPMENT TEST	COMPLETE
2-5	BOEING NOSE CAP	COMPLETE DEVELOPMENT TEST	7-31-64
2-12	ELEVON STRUCTURE	VERIFY STRUCTURAL INTEGRITY	1-15-65
5-3	PILOTS COMPARTMENT	LEAK & PROOF PRESSURE TEST	11-30-64
5-3	EQUIPMENT COMPARTMENT	LEAK & PROOF PRESSURE TEST	11-30-64
1-9	GUIDANCE & CONTROL MODEL	INSTALL AT WRIGHT FIELD FOR USAF	12-11-64
2-9	HIGH TEMPERATURE WINDOWS	VERIFY INTEGRITY OF SIDE WINDOWS	2-28-65
10-4	HEAT FLUX TRANSDUCER	DEVELOP INCIDENT HEAT FLUX SENSOR	4-30-65
10-4	LOW PRESSURE GAS MEASUREMENT	DEVELOP HIGH TEMP. -LOW PRESS. MEASURING SYSTEM	4-30-65
10-4	ULTRA VIOLET DENSITOMETER	DEVELOP AIRBORNE DENSITY MEASURING SYSTEM	4-30-65
10-4	HIGH TEMP. FLUTTER TRANSDUCER	DEVELOP 1400°F FLUTTER SENSOR	4-30-65
6-2	HYDROGEN TANK	ASSEMBLE & ACCEPTANCE TEST	10-31-64
6-3	OXYGEN TANK	ASSEMBLE & ACCEPTANCE TEST	10-31-64
6-5	H <sub>2</sub> SERVICING SYSTEM	ASSEMBLE & FUNCTIONAL TEST	10-31-64
6-6	O <sub>2</sub> SERVICING SYSTEM	ASSEMBLE & FUNCTIONAL TEST	10-31-64

1-1	CONTROL SURFACE BUZZ MODEL	ASSEMBLE FOR USAF TESTING	6-30-64
1-4	FLUTTER ANALYSIS CORRELATION	DOCUMENT & CORRELATE FLUTTER DATA	8-31-64
1-5	PANEL FLUTTER FLIGHT TEST	REPORT ON X-20 PANEL TESTS ON F-104	10-30-64
1-6	20% GROUND VIBRATION MODEL	COMPLETE MODEL & PERFORM TESTS	9-30-64
2-1	COMPUTER PROGRAMS	DOCUMENT 5 X-20 COMPUTER PROGRAMS	8-25-64
2-2	BOOST WINDS CRITERIA	DOCUMENT BOOST PHASE ANALYSIS	7-31-64
3-1	MATERIALS DEVELOPMENT	DOCUMENT MATERIALS ACCOMPLISHMENTS	1-30-65
----	WEIGHTS ANALYSIS REPORT	DOCUMENT WEIGHT ANALYSIS METHODS	8-1-64

The following references are supplied to furnish readers with a selected bibliography of key X-20 technical reports.

#### X-20 References

##### Static Stability

D2-80065      Aerodynamic Stability and Control Data,  
Model 844-2050

D2-8083      Glider Stability and Control Analysis,  
Model 844-2050

##### Aerodynamic Interaction Effects

ASD-TDR-63-148      Configuration Evolution Due to the Influence of  
(Vol. II)      Stability and Control

##### Hypersonic Aerodynamics

D2-8080-1      Glider Performance Characteristics Report

**Laminar Theory and Data Improvement**

D2-90138 Error Analysis and Methods for Correction of Thin Skin Heat Transfer Model Data

**Turbulent Heat Transfer**

D2-8108 Preliminary Aerothermodynamic Analysis Report

D2-8108-1 Addendum to Aerothermodynamic Environment Analysis Report

**Detail Design Heating**

D2-8108 Preliminary Aerothermodynamics Analysis Report

D2-8108-1 Addendum to Preliminary Aerothermodynamics Analysis Report

**Hypersonic Maneuver Capability**

D2-8080-1 Glider Performance Characteristics Report

D2-8083 Glider Stability and Control Analysis, Model 844-2050

**Energy Management Display Indicator**

D2-8080-1 Glider Performance Characteristics Report

D2-8088-5 Mission Guidance and Energy Management Analysis Report

D2-8143-1 Energy Management Display Study

D2-80073 Energy Management Overlay Analysis

D2-80869 Construction and Use of Dyna-Soar Energy Management Overlays

**Adaptive Gain Computer Performance**

D2-8129 Glider Flight Control Subsystem Analysis Report

D2-8083 Glider Stability and Control Analysis, Model 844-2050

**Piloted Boost Simulation**

D2-80762 Pilot in the Booster Control Loop Study -  
(Vol. I) Final Report

**Structural Component Advancement**

D2-81261 X-20 Engineering Summary Report of Structures and Material Technology

**Rene' 41 Hot Structure**

D2-80081 Primary Structure Development LT5-652, Shear Web and Panel Tests

D2-80272 Riveted and Bolted Joints of Refractory and Super Alloys

D2-80277 Heat Treatment of Rene' 41

D2-80278 Resistance Welding of Super Alloys

D2-80279 Fusion Welding of Super Alloys

D2-81242 Internal Loads Program

**Control Surfaces**

D2-80082 Control Surface Development - Dyna-Soar

D2-80084 External Surface Panels (Noninsulated) Development - Dyna-Soar (Vol. I and II)

**Landing Gear**

D2-80086 Landing Gear Development

**Insulated Surface Panels**

D2-80080 Insulated Panel Development

D2-80876 External Surface Seal Development

**Leading Edges Development**

D2-80085 Leading Edges Development

**Design Limits of Refractory Alloys**

D2-80275 Ductility of Silicide Coated TZM Molybdenum Alloys

D2-81113-1 Design Requirements for Coated Refractory Alloys

D2-81113-2 Design Requirements for Coated Refractory Alloys



### Coating Processes for Refractory Alloy Components

- D2-81108-1      Development of Oxidation Resistant Coatings for  
Columbium Alloys - Fluidized Bed Process
- D2-81108-2      Development of Oxidation Resistant Coatings for  
Columbium Alloys - Vacuum Pack Process
- D2-81109        Development of Oxidation Resistant Coatings for  
Molybdenum
- D2-81110        Emittance Improvement Coating Development for  
Refractory Alloys (Vol. I and II)

### Entry Capability of Coated Refractory Alloys

- D2-81111-1      Performance of Oxidation Resistant Coatings for  
Columbium Alloys
- D2-81111-2      Performance of Oxidation Resistant Coatings for  
Columbium Alloys
- D2-81112        Performance of Oxidation Resistant Coatings for  
Molybdenum (Vol. I and II)

### Nose Cap

- D2-80083        Nose Cap Development Testing
- D2-80287        Material Development Program, Boeing Nose Cap, X-20
- D2-80608        Fabrication of the Boeing Nose Cap

### High Temperature Thermal Insulations

- D2-80283        Development Programs, Thermal Insulations, X-20
- D2-80755        Ceramic Fiber High-Temperature Thermal Insulation  
Development

### Other Structural Developments

- D2-80088        Window Development - Dyna-Soar
- D2-80092        Cryogenic Tanks Development - Dyna-Soar
- D2-80270        Welding of Columbium Alloys
- D2-80281        Thermal Properties Measurement Techniques
- D2-80284        Window Materials Development

- D2-80535 Fabrication Requirements for Cryogenic Tanks
- D2-80670 Fabrication of Columbium Alloy Antennas for X-20A
- D2-80876 External Surface Seal Development Test

#### Landing Skids

- D2-80777 Test and Data Report - Dyna-Soar Landing Gear High Speed Development Test

#### Hydraulic Servoactuator

- D2-80280 Hydraulic Fluids Evaluation
- D2-81020 Test Report - First Elevon Prototype Servo Actuator
- D2-81021 Test Report - Guidance and Control Development Model, X-20 Elevon Hydraulic Power Servos
- D2-81033 Hydraulic Tubing and Fitting Evaluation Test Program
- D2-81034 Hydraulic System Metallic and Elastomeric Seal Evaluation Test
- D2-81096 Development of Insulated Hydraulic Tubing and Servo Wiring Assemblies

#### Water-Wall Development

- D2-80603 Water-Wall Construction
- D2-80803-2 Qualification Test Report for Water-Wall
- D2-80812 Water-Wall Development Testing Report

#### Integrated Hydrogen Cooling and Power Generator System

- D2-80001-3 Analog Computer Simulation of the Dyna-Soar Glider (Vol. I and II) Integrated Environmental Control and Secondary Power Subsystems
- D2-80448 Cryogenic Subsystem Design Development Tests
- D2-81138 Breadboard Cryogenic Development Test Results (Vol. I and II)

## NOTES

1. Aero-Space Division, The Boeing Company, Summary of Technical Advances: X-20 Program, D2-23418 (Seattle, WA: The Boeing Company, July 1964), passim. For the benefit of the reader, I have numbered the figures, deleted extraneous material, and consolidated the references according to subject. This report, now unclassified, is in the Shuttle records collection of the NASA Lyndon B. Johnson Space Center in the "July 1964" file. This collection of material, assembled by former NASA LBJ Historian Jim Grimwood and archivist Sally D. Gates, is part of a collection of material recently transferred to Rice University as part of a NASA-Rice archives agreement. I wish to acknowledge my debt to Mr. Grimwood and the late Sally Gates for their assistance during my research into the Johnson Space Center records collection.



CASE III

THE DEVELOPMENT OF WINGED REENTRY VEHICLES:  
AN ESSAY FROM THE NACA-NASA PERSPECTIVE, 1952-1963

by

John V. Becker

## EDITOR'S INTRODUCTION

To a great extent, the history of aerospace development in the United States is a history that can be documented in the work of a unique federal institution: the National Advisory Committee for Aeronautics (NACA) and its successor, the National Aeronautics and Space Administration (NASA). Created by an act of Congress in 1915 to "undertake the scientific study of the problems of flight with a view to their practical solution," the NACA contributed meaningfully to a number of important technical areas, none more so than the arena of high-speed flight. The agency did this primarily through creative and insightful wind tunnel research at its two major research centers, the Langley Memorial Aeronautical Laboratory at Hampton, Virginia, and at the Ames Aeronautical Laboratory at Moffett Field, California. Both of these eventually became individual research centers under the new NASA formed in 1958.

NACA's interest in supersonic flight dated to the early 1920s, when agency engineers first studied "compressible" flow problems of rotating propellers. During the late 1930s, individual NACA researchers postulated development of new high speed wind tunnels and wind tunnel test techniques, and new methods of free-flight testing as well. This work eventually led to such developments as the transonic tunnel "bump," the slotted-throat transonic tunnel, falling body and rocket-propelled research models, and (in partnership with the military and industry) full-size transonic and supersonic research airplanes. As the supersonic era became a practical reality, design teams continued to rely upon NACA work, exemplified by the agency's development of the area rule concept, conical camber theory, and studies on the problems of swept wing pitch-up, and inertial coupling (coupled-motion instability, as

encountered on such early supersonic aircraft as the F-100 and X-3).

Nowhere were NACA and later NASA researchers more active than in the field of lifting reentry studies. In the early 1950s, H. Julian Allen of Ames laboratory had postulated the notion of blunt body reentry, and his work took form on the first ballistic missile reentry warhead shapes as well as on the subsequent Project Mercury spacecraft. His "disciples," Alfred Eggers and Clarence Syvertson, took this a step further with investigations of tailored blunt body shapes that could generate modest lift--and out of this eventually evolved the so-called M2 "Cadillac" shape, a modified half-cone with boat-tailing and a rounded nose as well as two prominent (hence the name) vertical fins. But the NACA had always been more comfortable with winged approaches to flight, and thus NACA's premier center--the Langley laboratory at Hampton--concentrated on winged conceptualizations, though it also generated some lifting body configurations as well. Chief among the proponents of winged lifting reentry from space was a distinguished aerospace physicist, John V. Becker, who, more than any other single individual, was responsible for the X-15 program and who eventually followed this by serving as project manager on Dyna-Soar for the NASA.

It is fortunate that in addition to being a practitioner, Becker is a thoughtful commentator and historian as well. The following case study offers a unique opportunity to examine the evolutionary approaches taken to lifting reentry within the framework of a single organization, from the perspective of a key participant and a dedicated NACA-NASA employee. This study was privately prepared by John Becker in May 1983 as a "lessons learned" document to specifically address some of the misconceptions and misleading generalizations that have sprung up concerning lifting reentry work by the NACA and its successor, the NASA.





## THE DEVELOPMENT OF WINGED REENTRY VEHICLES:

AN ESSAY FROM THE NACA-NASA PERSPECTIVE, 1952-1963

These notes review briefly, from the viewpoint of a NACA/NASA participant, the conceptual evolution and related technical advances through which manned reentry vehicles progressed from a state of questionable feasibility, through minimal ballistic capsules, to the ultimate sophistication of maneuverable, landable, reusable winged systems. Some pertinent information not found in the existing literature will be presented, together with discussion of some significant misconceptions.

The literature surrounding the impressive successes of the winged Space Shuttle quite rightly emphasizes the development of the reusable ceramic tile heat protection system, the enormous boosters, and the elaborate automatic flight-control systems. Little is said, however, about the aerodynamic design features and the modes of operation during reentry; these were established some 20 years before the first Shuttle orbital flight and have been so widely accepted for so long that they are now taken for granted. But it was not always so, and these notes record how the optimal design features and modes of operation evolved and eventually became established.

The author spent most of his professional career in high-speed aerodynamics with NACA and NASA from 1936 to 1974, serving as a research division chief from 1947 to 1974. After retirement from NASA he was active as a consultant, and during this period he authored two previous documents of a historical nature.\*

---

\*The High-Speed Frontier, NASA SP-445, 1980, and A Hindsight Study of the NASA Hypersonic Research Engine, a study prepared for the Propulsion Division of NASA/OART in 1976.

## The Outlook in 1952

The overriding real-life focus for hypersonics research in 1952 was the problems of the various long-range missile concepts. Our Hypersonics and Gas Dynamics groups at Langley, which had been formed in 1945 and 1948, were busily engaged in general exploratory hypersonic aerodynamics and heating research, and in occasional specific missile configuration testing for RAND and others. Our principal tool was the Langley 11-inch hypersonic tunnel which was this country's first hypersonic facility, conceived and proposed in 1945, and operated successfully at Mach 6.9 for the first time in 1947. Our Gas Dynamics Laboratory, which contained several hypersonic nozzles, came into operation a few years later, in the early '50s. In the late '40s Ames also became involved in missile-related research, and in the early '50s H. J. Allen completed his famous "blunt-body" contribution. Many of us had read the S<sup>ä</sup>nger-Bredt papers and more recently the first progress reports on the studies of military manned boost-glide systems being undertaken at Bell Aircraft. These documents were most stimulating, but there was such a multiplicity of enormous technical problems that these systems seemed very far in the future. Manned space flight with its added problems and the unanswered questions of safe return to earth was seen then as a 21st Century enterprise. In our wildest fancies none of us visualized it actually happening, as it did, within the decade.

The 1952 recommendation of the NACA Aerodynamics Committee for increased emphasis on hypersonics research at Mach 4 to 10 had little immediate effect on the existing Langley programs, with the exception that it inspired the PARD group to evaluate the possibilities of increasing the speeds of their test rockets up to Mach 10 (Ref. 1). The rest of us who had actually been expanding our efforts in hypersonics substantially for the past five years were gratified to see NACA management "getting up to speed." The

final part of the recommendation "to devote a modest effort" to the speed range from Mach 10 to the speeds of space flight was responded to at Langley by setting up an ad hoc 3-man study group consisting of C. E. Brown, Chairman, from my Compressibility Research Division; C. H. Zimmerman of Stability and Control; and W. J. O'Sullivan of the Pilotless Aircraft Division (PARAD). The Brown group was asked to assess the problems, develop research program ideas, and, following the suggestions of Bob Woods of Bell Aircraft, to define a manned research airplane capable of penetrating the hypersonic flight regime. The group met periodically for several months and then disbanded. Their report was circulated internally in June of 1953 (Ref. 2).

#### The Brown-Zimmerman-O'Sullivan Study

Outside of our two small groups in the Compressibility Research Division, very few others at Langley in 1952 had any knowledge of hypersonics. Thus the Brown group filled an important educational function badly needed at that time. In the process they had to educate themselves, since none of the three had any significant previous background in hypersonics. When Floyd Thompson told me of his plan to set up such a group, I suggested adding one of our hypersonic aerodynamicists and also a budding specialist in hot-structures from the Structures Division. Thompson rejected the suggestion saying that he was looking for completely fresh unbiased ideas and had picked three individuals who had previously shown much originality in their respective fields; they would ask for help from the experts when they needed it.

The Brown group made an interesting review of the potentialities of hypersonic systems at speeds up to orbital, and they became interested especially in the commercial possibilities of the boost-glide rocket system for long-range transport, a scheme not previously explored to any extent in the literature. As

regards needed research programs, they rejected the traditional use of ground facilities and indicated that testing would have to be done in actual flight where the true high-temperature hypersonic environment would be generated. To do this they suggested extending the Wallops-Island rocket-model technique to much higher speeds with possible test model recovery in the Sahara. In response to their directive to consider a manned research airplane to follow the X-2, they endorsed an earlier proposal of Dave Stone to extend the X-2 to the Mach 4 to 5 range, a proposal shortly rejected by the Research Airplane Panel.

Listening to Brown summarize the study early in 1953, our hypersonic specialists felt a strong sense of deja-vu, especially at his pronouncement that "the main problem of hypersonic flight is aerodynamic heating." Nevertheless this was timely education in the basics for the uninitiated in Langley and NACA headquarters managements. Fortunately the group's conclusion that flight testing, rather than ground-based approaches, would have to be relied on for hypersonic R&D, which proved to be quite wrong, did not slow the progress of any of our developing ground techniques. As everyone in the business now knows, hypersonic ground facilities generally do not attempt to simulate the high-temperature features of the hypersonic environment at the higher speeds; however, it has proved possible and quite practical through the principles of partial simulation in a variety of ground facilities both to advance basic technology and to support the development of uniformly successful hypersonic systems ranging from ICBM's to the Space Shuttle (see Ref. 3, for example). Selective flight testing, usually of the final article, is often desirable just as it has always been throughout aircraft history - but ground-based techniques (rather than flight) remained the primary tools of hypersonic R&D.

The original plan to have the Brown Group's results reviewed by an inter-center Board was never carried out.

Several misconceptions regarding presumed connections of the Brown Group's study with subsequent projects have appeared in the historical literature which need to be corrected. This New Ocean, for example, states on p. 57 that "the Langley Study Group which had been working on the problem since 1952," - presumably the Brown group - was the source of NACA's proposal in July of 1954 leading to the X-15. Actually, as has been documented in full detail in Ref. 4, the X-15 concept originated in a 1954 study by Becker, Faget, Toll, and Whitten which made no use whatever of any of the Brown group's study. This misconception, which has arisen on other occasions, probably has its roots in the careless and incorrect wording found in the "NACA Views" document of August 1954 (Ref. 5), where no clear distinction was made between the Brown group of 1952 and the X-15 group of 1954. Written in the slanted officious style typical of the promotional literature of federal agencies the "NACA Views" contains other inaccuracies, for a notable example, the statement on page 2 that "independent studies" at the other NACA Labs "were markedly in agreement (with Langley's pre-X-15 study) concerning feasibility, goals, . . . and general arrangement of the airplane." The truth is that Ames favored a military-type air breather for Mach 4 to 5. The Lewis Lab recommended against a manned airplane (Ref. 4).

Another unwarranted claim is seen in A New Dimension, NASA Ref. Publ. 1028, on p. 288 where author Shortal states that the Brown group study "excited Langley interest" in a boost-glide system follow-on to the X-15 "to become known as Round III and later as the NACA/USAF Dyna Soar Project." As one of the two or three individuals at Langley most deeply involved in these later boost-glide programs, I can state positively that their origins sprang solely from military applications and interests. At most, the Brown group study provided Langley with useful background education. The commercial transport version of boost-glide that the Brown trio visualized did not survive in later studies (see NASA SP-292, p. 429-445).

## Bell Aircraft Company Studies of Boost-Glide Military Systems

Walter Dornberger, former German Army Commander of Peenemünde who was hired by Bell after the war, directed a succession of studies at Bell which had great educational value for the NACA and the Air Force. Essentially these were greatly advanced and improved Sänger concepts incorporating advanced technology and greater technical depth. Of special value and interest were Bell's new structural concepts, due largely to Wilfred Dukes' group - the first hypersonic aircraft hot structures concepts to be developed in realistic meaningful detail. These included wing structures protected by non-load-bearing flexible metallic radiative heat shields or "shingles," cabin structures employing both passive and active cooling systems to keep the interior temperatures within human tolerance, and water-cooled leading-edge structures. Bell recognized that there were enormous gaps between their preliminary concepts and actual realization, and like most of their contemporaries in the fifties they usually recommended "vigorous" research programs to fill the gaps.

Periodic progress reports of the Bell Studies of the 1950-57 period were circulated to the interested NACA research groups, including the Brown group, the X-15 group, and the Round III groups. Unfortunately, they were usually classified "Secret" by the Air Force and thus were generally not used as references in NACA reports, which ordinarily were classified "Confidential" or lower. With little question Bell's "Bomi," "Brass Bell," and "Robo" studies provided the principal stimulus for USAF interest in boost-glide systems culminating in 1956 in USAF's proposals for the HYWARDS research program and later for the Dyna-Soar program. The rapid expansion after 1954 of NACA studies of boost-glide systems, hypersonic glider aerodynamics heating, and structures was greatly stimulated and benefitted by Bell's work on these military systems.

## The First Manned Winged "Reentry" Vehicle:

### The X-15

Dr. Hugh L. Dryden used to liken the X-15's great elliptic excursion out of the atmosphere into space to the leap of a fish out of water. Our original intent was to create a period of two to three minutes of weightlessness for a first exploration of the effects of this characteristic feature of space flight (Ref. 5). But as the Langley study of March 1954 progressed, we soon realized that the problems of attitude control in space and the transition from airless to atmospheric flight during reentry were at least equally significant to the weightlessness question (Ref. 4). And as time went on, the dynamics of the reentry maneuvers and associated problems of stability, control, and heating emerged as clearly the most difficult and significant of the entire program (Ref. 3).

The X-15's reentry problems were similar in all important respects to those of the Space Shuttle: the transition from space reaction controls to aerodynamic controls; the use of high angles of attack to keep the dynamic pressures and the heating problems within bounds; and the need for artificial damping and other automatic stability and control devices to aid the pilot. These automatic systems were in an early stage of development in the '50s and the X-15's pilots had to contribute piloting skills beyond those required in the Shuttle operation. Any advantage over the Shuttle reentry accruing from the lower speed of the X-15 tended to be offset by the much steeper reentry paths of the X-15. The pioneering X-15's reentry systems and their derivatives and the X-15's reentry flight experiences led directly to the systems and techniques employed in the Dyna-Soar and later in the Shuttle. The reaction control system used in the X-15's space leap also found application in the Mercury, Gemini, and Apollo systems.

An interesting facet of the original heating analysis of the X-15's reentry from its "space leap," made by Becker and Peter F. Korycinski under forced draft in their long work days of March and April 1954, is worth noting. We discovered that Mach 7 reentry at low angles of attack was impossible: the dynamic pressures quickly exceeded by large margins the limit of 1000 lb/sq ft set by structures considerations, and the heating loads became disastrous. However, we found that these problems were solvable by using sufficient lift during reentry - the higher the angle and the associated lift the higher the flight altitude and the lower the peak dynamic pressure and the lower the heating rates. The reduced L/D's characteristic of the higher angles of attack reduced the times of exposure to high heating rates, thus reducing the reentry heat loads as well as the heating rates. On reflection it became obvious to us that what we were seeing here was a new manifestation of H. J. Allen's "blunt body" principle. As we increased angle of attack our configuration in effect became more "blunt," dissipating more of its kinetic energy through heating of the atmosphere and less in the form of frictional heating of the vehicle. Clearly, Allen's concept was as meaningful in our high-lift X-15's reentry as it was in the non-lifting missile cases he had considered in 1952.

The figure in Ref. 4 which depicts the trajectories and vehicle altitudes which were found feasible from the heating standpoint shows that dive brakes could be employed in conjunction with lift to increase drag and further reduce L/D in order to ease the heating problem - again in accord with Allen's "Blunt-Body" concept. Unfortunately the limited treatment of the heating studies reported in Ref. 4 did not include all of the implications of high-lift high-drag reentry. These details were discussed, however, in most of the oral presentations we made throughout 1954. The problems of how to make the X-15's configuration stable and controllable in the high-angle-of-attack (11 to 26 degrees) regime



involved in its "reentry" trajectory outweighed the heating considerations at that time. Nevertheless our heating analysis provided the first clear detailed insights into the reentry heating problems of winged vehicles and their possible solution by use of combined high lift and high drag. This new knowledge was invaluable in our later work on the "HYWARDS" and "Dyna-Soar" projects in which we extended studies of high-lift and high-drag reentry to near-orbital speeds for delta wings operating at angles of attack up to 45 degrees.

#### Ames' Exploratory Comparative Study of Hypersonic Systems

This 1954 study (Ref. 6) was started at about the same time as the pre-X-15 work at Langley. It was concerned solely with sub-orbital long-range flight and did not consider orbital operations or reentry. H. J. Allen made the first review of their results a year and a half later in November 1955 at the Langley Conference on High-Speed Aerodynamics. In retrospect the study was interesting and important on three counts:

1. Its comparisons of rocket and air breathing systems.
2. The unveiling of the Ames' so-called "flat-top" drooped-wing-tip glider for intercontinental ranges.
3. The finding that the simple, blunt-shaped, ballistic capsule was the optimal vehicle from an energy standpoint for very long ranges (semi-global or greater).

In regard to Item 3 Allen liked to explain, "For very long ranges it is better to throw it than to fly it." Of course, his ballistic vehicle had some unpleasant characteristics: high deceleration rates and the necessity of an uncontrolled parachute landing if it were to be recovered.

Over four years later after much additional study and new technology for satellite reentry had been added by Industry, by Langley, by Ames, and by others, a "final" version of Ref. 6 - having the same title but much embellished - was published as NACA TR 1382. The authors of This New Ocean (pp. 66-68) mistakenly assumed that all of the insights acquired by 1959 in this study were at hand in 1954. It should be noted especially that the desirable features and operational techniques of winged satellite reentry vehicles did not exist either in the 1954 study or in Allen's 1955 review.

What is true and what should be noted by historians is the fact that the studies of hypersonic glider systems by Bell, Langley, Ames and others in the early '50s were a most pertinent and important prelude to the successful satellite reentry vehicle technology developed later in the decade. In many respects the environmental and operational problems of reentry from orbit along a shallow (gradually descending) trajectory are quite similar to those of the sub-orbital glider system. Thus X-15, HYWARDS, and Dyna-Soar were important precursors of the Shuttle. And Allen's sub-orbital ballistic system of 1954-55 led directly to the project Mercury concept.

#### Project "HYWARDS"

We were surprised in March 1956 to learn from the Air Research and Development Command (ARDC) staff that the USAF was establishing a specific project to develop a research airplane successor to the X-15. After one of the Bell Aircraft Company's briefings on their Robo study, we NACA invitees were told that USAF/ARDC management was determined never again to find themselves unprepared as they were when NACA proposed the X-15 and gained technical direction of the X-15 project. USAF's only specification for such a new research vehicle at that time was "a rocket glider with a speed of

about Mach 12." "HYWARDS" was the acronym for this hypersonic weapon and R and D system.

Although we were very busy at Langley in the spring of 1956 with supporting research for the X-15, it was obvious that the question of a successor merited high-priority attention. Floyd L. Thompson immediately set up an ad hoc inter-divisional study group patterned directly after the X-15 group. It was larger, however, and had more time to fulfill its task. The principal members of our "HYWARDS" study group were:

J. V. Becker, Chairman; also leader of the Heating Analysis group

- M. Faget, Propulsion & Configuration
- L. Sternfield, Stability, Control, Piloting
- F. J. Bailey, Stability, Control, Piloting
- I. Taback, Instrumentation, Range, Navigation
- R. Anderson, Structures, Materials
- P. Purser, Structures, Materials
- P. Doneley, Loads and Flutter
- A. Vogeley, Operations and X-15 Coordination
- P. Korycinski, Coordination; Heating group

As the work progressed, a number of others were added, notably:

- P. Hill, Configuration, Propulsion
- E. Love, Configuration, Aerodynamics, Stability & Control
- M. Bertram, Configuration, Aerodynamics, Stability & Control

As a starting point we decided to focus on a design speed of Mach 15 for purposes of analysis, not at all sure that it would prove feasible, but believing that it was about the lowest speed for which an attractive military boost-glide mission could be defined. Perhaps the most important recommendation in our first

formal report of the study on January 17, 1957, (Ref. 7) was that the design goal should be raised to 18,000 feet per second or about Mach 18. We had learned in our heating analysis that at this speed boost gliders approached their peak heating environment. The rapidly increasing flight altitudes at speeds above Mach 18 caused a reduction in heating rates; at satellite speed, of course, on the outer fringe of the atmosphere the heating rates became negligible. Mach 18 was an enormous step beyond the X-15, requiring new developments in every area of applicable technology. Promising general concepts for these developments were formulated; however, in many areas, especially in high-temperature internally-cooled structures, we were confronted by enormously complex development problems. Our expressed hope that such a system could be developed and ready for flight in five years appears, in retrospect, to be far too optimistic.

Our proposed vehicle system embodied advanced glider prototype concepts both aerodynamically and structurally. The heating analyses carried out by Becker and Korycinski had revealed major advantages for a configuration having a flat bottom surface for the delta-wing, and a fuselage located in the relatively cool shielded region on the top or lee side of the wing - i.e., the wing was used in effect as a partial heat shield for the fuselage and its critical contents. This "flat-bottomed" design had the least possible critical heating area for a given wing loading and this translated into least circulating coolant, least area of radiative heat shields, and least total thermal protection in flight (Fig. 1). In these respects the configuration differed importantly from the previous Bell designs, which employed mid-wing arrangements. This was the first clear delineation of the possibility of aerodynamic design features which could significantly alleviate the heating and ease the hot-structures problems. Later application of these principles to actual flight systems was first made in the Dyna-Soar program, and they are also obviously applied in the current Space Shuttle.

Fig. 1. Results of calculations made in early 1957 showing weight superiority of Langley's flat-bottomed configuration over the flat-top advocated by Ames. From the heating analysis of Becker and Korycinski and thermal-protection weight estimates of Roger Anderson and others in the Structures Division. The flat-bottomed concept was later adopted in conceptual reentry designs and the Dyna-Soar and Space Shuttle vehicles.

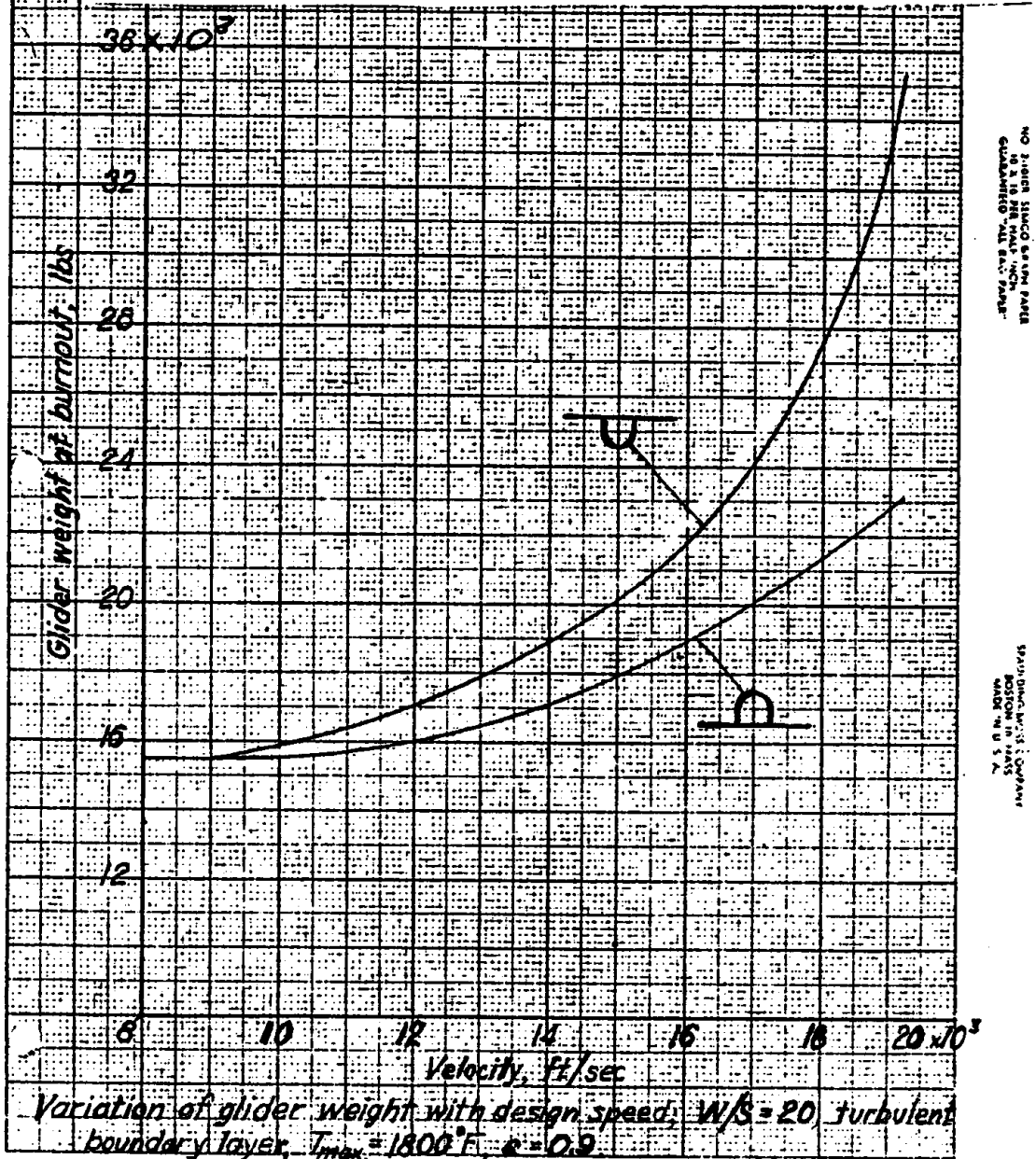


Figure 1

In the major review of our HYWARDS study for Langley top management on January 11, 1957, Becker also discussed operation of the Langley glider if boosted to the near-orbital velocity required for once-around or "global" range. Using Fig. 2 he pointed out that the maximum-L/D mode of operation resulted in much more difficult temperatures and heating loads than if the glider were operated at half its maximum L/D and high angles of attack. Still further alleviations would be expected if the vehicle were operated at its maximum lift (L/D~1, 45° angle of attack) (Ref. 8, copy attached). High L/D operation made sense only for the shorter ranges.

During the period in 1955 when the work statement for the X-15's design competition was being formulated at Langley, I had received several phone calls from A. J. Eggers at Ames expressing concern that the work statement did not specify very high aerodynamic efficiency (i.e., very high Lift/Drag ratio). They proposed to add to the X-15's design problems the enormous complications that would have been involved to make it an advanced prototype of their early notions at that time of what the ultimate long-range glide vehicle should look like. I protested that this would delay the procurement unacceptably without adding materially to the research products envisioned for this exploratory penetration into the realm of manned hypersonic flight. Soule and NACA HQ personnel agreed.

When "HYWARDS" appeared in the spring of 1956 the Ames group saw at last an opportunity to promote their penchant for high Lift/Drag and they set up a study group consisting of A. J. Eggers, G. Goodwin, R. Crane, H. J. Allen, L. Clausen and others. Their proposal (Ref. 9) called for a speed of Mach 10 which produced a range of only about 2000 miles even though their glider was designed for the highest conceivable hypersonic Lift/Drag ratio (about 6). To favor high L/D they made use of the favorable

## GLOBAL TRAJECTORIES

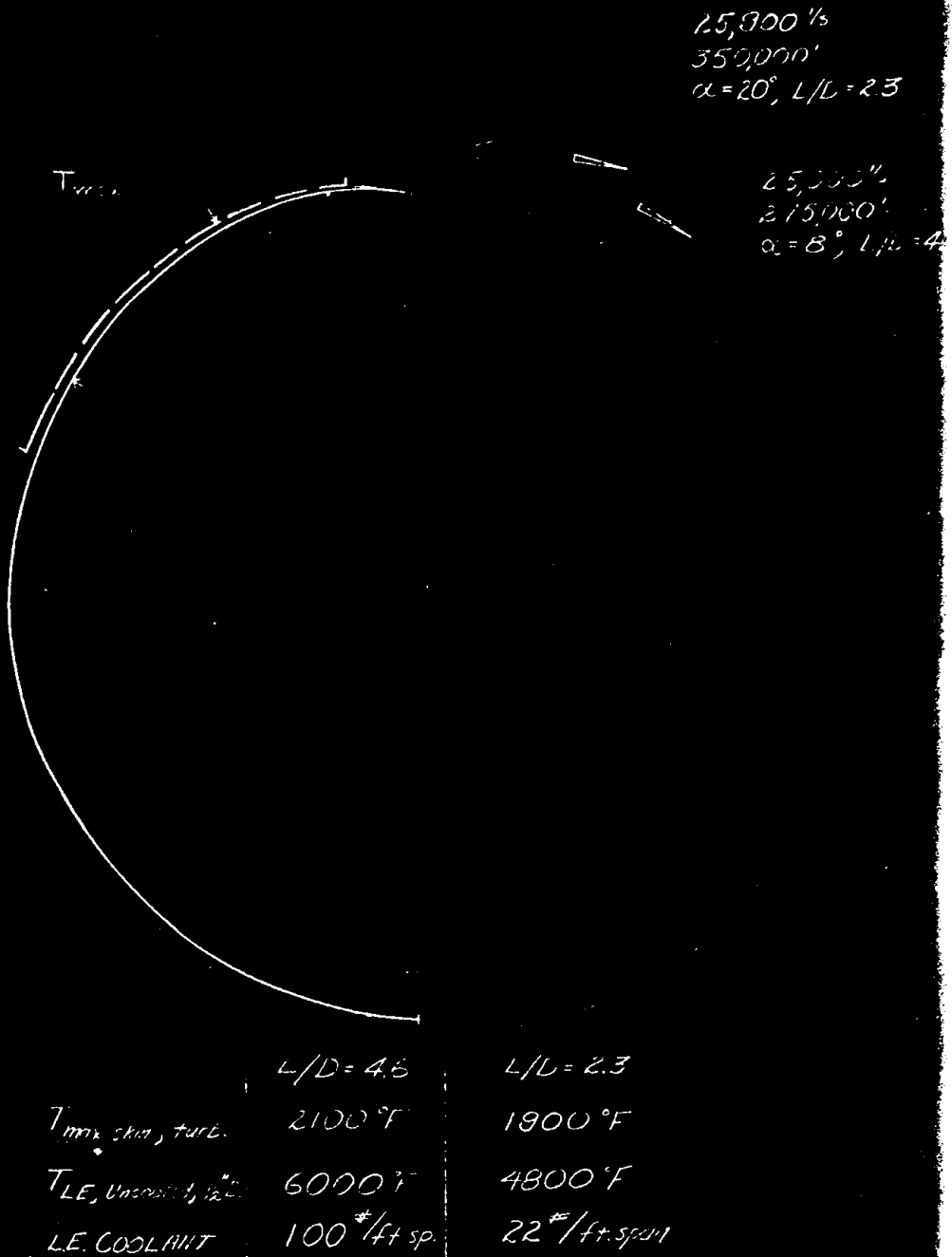


Fig. 2. Chart developed in Langley HYWARDS study for presentation to Langley management on Jan.11,1957, showing heating alleviation for global-range glides by operation at high angle of attack and reduced L/D. (See Ref.8)

Figure 2

interference lift that occurs when the pressure field of an underslung conical fuselage impinges on the wing. In this concept, unfortunately, the entire fuselage with its critical special cooling requirements was located in the hottest region of the wing flow field - on the high pressure lower surface where added thermal protection weight was required. Although the Ames' report virtuously stated that the configuration should be "capable of the highest possible Lift/Drag ratio consistent with . . . (other requirements)" it was apparent to us that actually their configuration had 'the highest possible L/D without regard for the other requirements.' The drooped wing tips of the Ames' configuration were supposed to add slightly to the L/D but their use did not survive later careful evaluations in the Supersonic Transport programs.

A comparison of the Ames' and Langley vehicles initially proposed for HYWARDS is seen in Fig. 3. A rather noticeable feature of the Langley design is the large cones attached to the elevons. These were proposed by Eugene S. Love to provide sure effectiveness for both directional and longitudinal stability and control at the higher speeds. They were shortly discarded in favor of separate toed-in tip fins and rudders which proved better from the L/D and heating standpoints.

Aside from the questions relating to the "flat-top" arrangement, the least supportable feature of the Ames' proposal was the low design speed they recommended, about Mach 10. Eggers made a mild attempt to justify this speed at the first meeting of the Steering Committee for these Research Vehicles on February 14, 1957, (Ref. 10). Shortly after this meeting, however, Ames decided to accept our reasoning for 18,000 ft/sec, and on May 17 they forwarded a Supplemental Report describing their 18,000 ft/sec system (Ref. 11). High L/D was still retained as the primary feature of their new design.



Figure 3

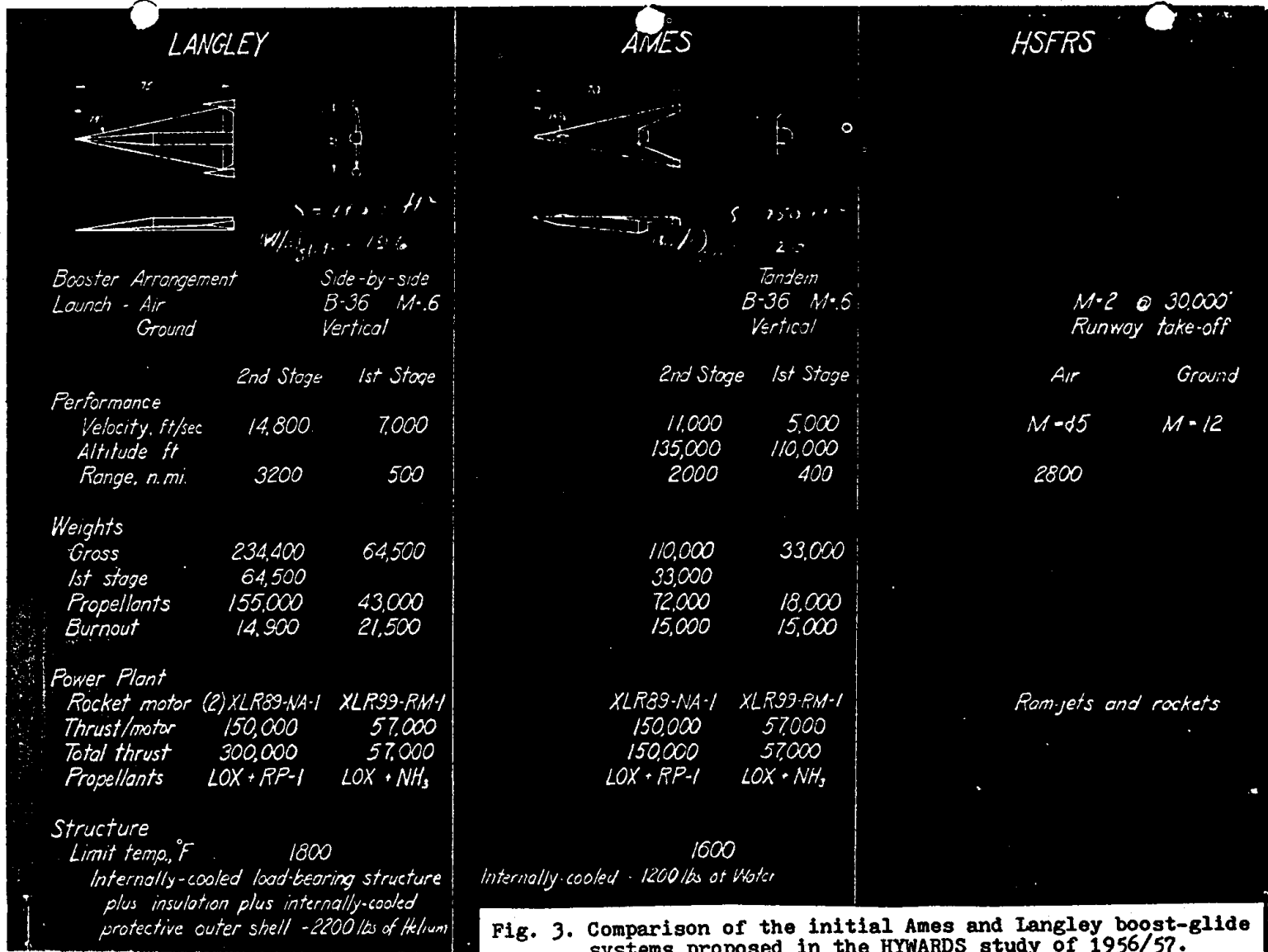


Fig. 3. Comparison of the initial Ames and Langley boost-glide systems proposed in the HYWARDS study of 1956/57.

Ames' predilection for high-L/D needs to be explained. The possibilities for combining aerodynamic bodies--wing and fuselage in particular--so as to produce beneficial aerodynamic interference effects had become one of the most intriguing aspects of configuration research in the late '40s and early '50s--stimulated perhaps by the great success of Whitcomb's Transonic Area Rule developments. A number of researchers at Ames were deeply involved in the improvement of supersonic configurations through favorable interference. At the same time Ames did not have a significant effort in high-temperature structures and heat protection. This area of research was centered at Langley. Thus the Ames' emphasis on high-L/D in the hypersonic research airplanes was simply a reflection of their established primary research interest rather than any special understanding or analysis of the real-life trade-offs that must be made between high-L/D, structural weight, and, especially for hypersonic aircraft, heat-protection-system weight.

NACA management was now faced with the problem of how to deal with these two distinctly different configuration philosophies. To provide some needed background information and at the same time promote our Langley ideas in which I believed strongly, I constructed Fig. 4 for discussion at a major presentation to Langley management in May 1957. Based on analysis of the range equation for a circular earth, the results showed that due to the large centrifugal lift at Mach 18, the traditional aerodynamic efficiency factor, Lift/Drag, has less than half of the relative effect on range than it has at low flight speeds. At the same time, aircraft weight, which is increased by high L/D, retains the same large importance that it exerts at low speeds. To further stress the point, I prepared Fig. 5 showing that for the extreme case of once-around or "global" range an L/D = 1 vehicle required only a slightly higher boost speed than the L/D = 4 vehicle. More importantly, the L/D~1 vehicle, operating at its maximum lift angle of attack (45°) had greatly reduced heating problems, and this

Effect of speed on the relative importance of L/D & STRUCTURAL WGT.

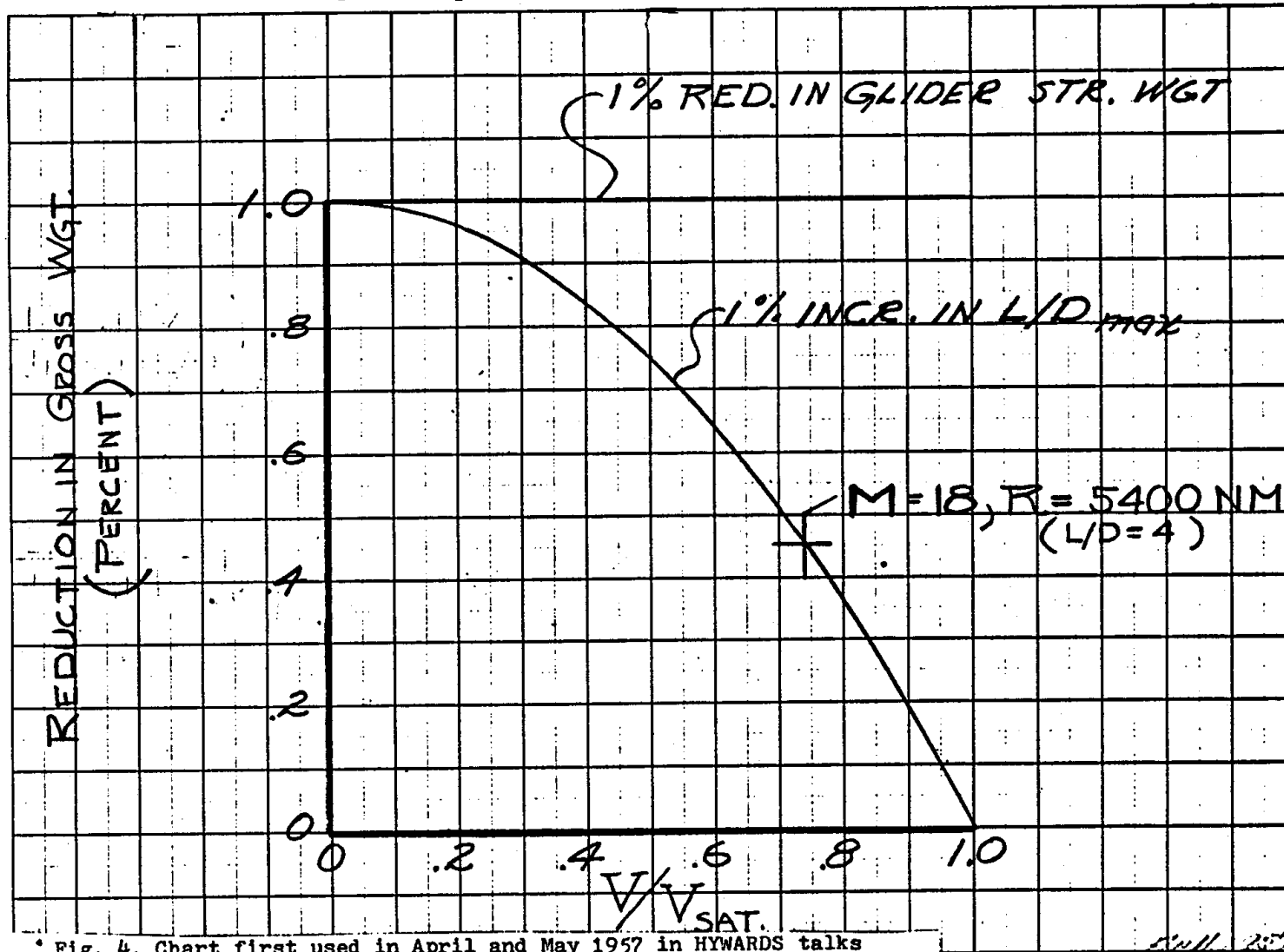


Figure 4

\* Fig. 4. Chart first used in April and May 1957 in HYWARDS talks at Langley to show the decreased relative importance of L/D at high hypersonic speeds, and the constant importance of structural weight.



GLOBAL TRAJECTORIES

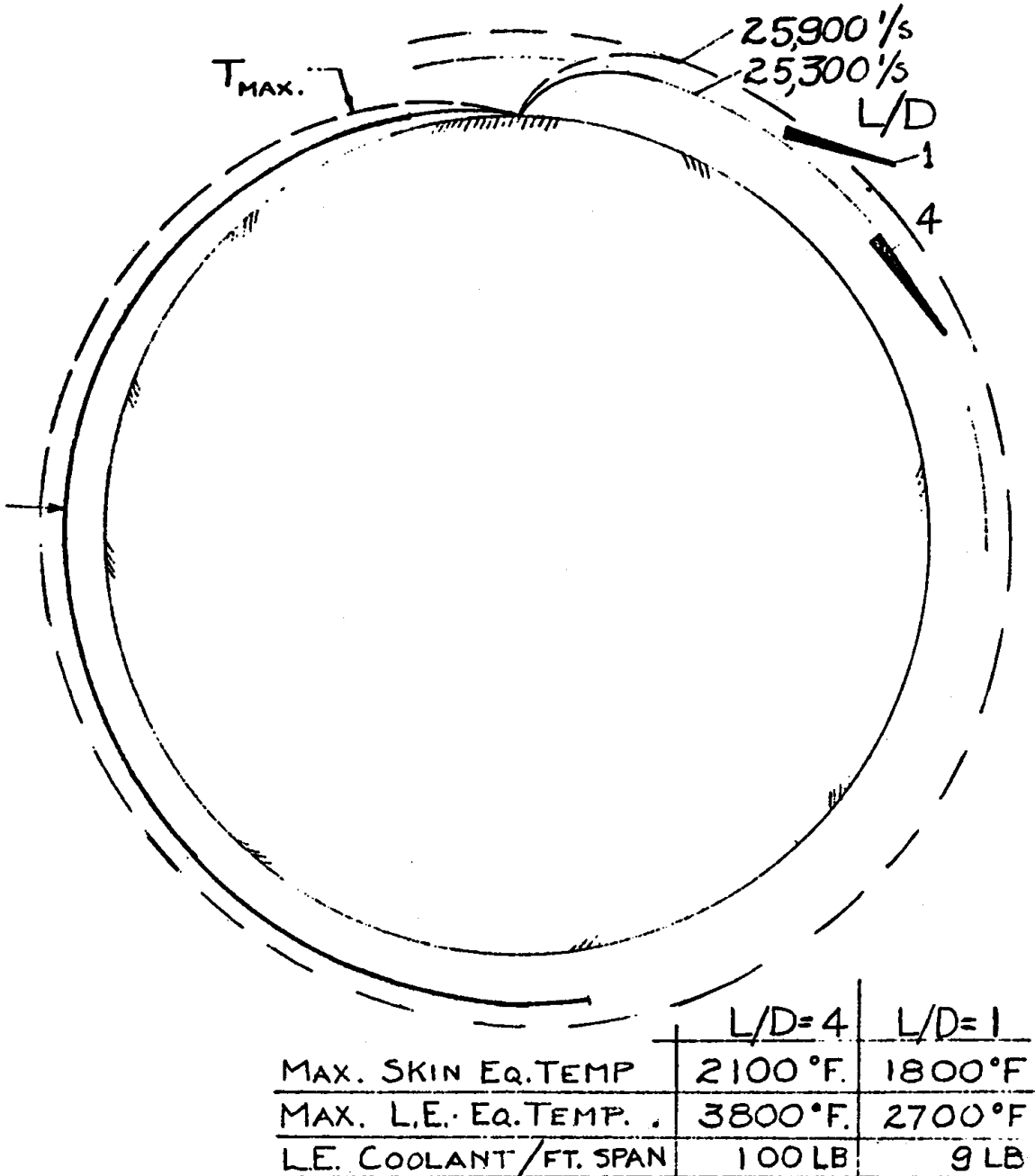


Fig. 5. Langley chart dated May 1, 1957, extending the idea of high-angle-of-attack operation to maximum lift ~~60-45°~~ ( $L/D \sim 1$ ) for global-range flights. Most of the range is covered on the outer fringe of the atmosphere at low heating rates; peak deceleration and heating occur near the end of the trajectory. Skin temperatures and coolant requirements greatly reduced in comparison to the high- $L/D$  flight.

5/1/57

meant that it could be smaller and lighter than the L/D~4 vehicle. This result, of course, came as no surprise to us at Langley since we had discovered the heating advantages of high-lift low L/D operation in our X-15 study as mentioned previously. This was the first specific delineation of an important principle of operation later employed in the Dyna-Soar and Space Shuttle systems.

A "NACA Views" document for the HYWARDS study (Ref. 13) was written at Langley, chiefly by key members of the Langley team, during the late spring of 1957. In the interests of peace and brotherhood both the Langley and Ames' vehicles were included, to illustrate two alternative approaches, "low-heating" and "high-L/D." Editing by Soule' and Mulac at Langley and Clotaire Wood in NACA HQ strove for fine impartiality. A number of presentations of the content of this document were made during the spring at Langley, Ames, NACA HQ, and at the Pentagon on July 11. General Putt and Dr. Dryden indicated that further steps towards an advanced program of this kind were in order, but should be taken with discretion so as not to jeopardize the X-15 program which was still having funding problems.

#### The NACA "Round III" Meeting at Ames on October 16-18, 1957

The intent of this gathering was to permit detailed discussion and coordination of the work of the four NACA Laboratories relating to HYWARDS, at the working level and at upper management levels as well. It was very much needed because of the strong differences of opinion which had developed, particularly in regard to the glider configuration concepts. In the "Views" (Ref. 12) it was stated that the Ames' high-L/D approach would have a range advantage of some 1,300 miles if launched at the same speed, 18,000 ft/sec, as the Langley glider. However, it was easy to show by simple engineering calculations that the glider weight penalty associated with the higher L/D would, for equal system weights, nullify this

range advantage. This important fact had been edited out of the "Views" in the interest of harmony.

Reflecting on the above as objectively as possible, I realized that both the Ames' and the Langley designs were probably far from optimum. We had simply selected "reasonable" but arbitrary values for wing loading, skin temperature, etc. A truly optimized vehicle - in which the trade-offs among the key variables had been systematically evaluated - might have different proportions, features, and R&D problems. It was rather foolish for both groups to be so vociferously wedded to their present configurations. I decided this was the most important point I could make at the Round III meeting. To make the point convincingly I analyzed the effects on the performance of the Langley glider due to changes in wing size and wing loading. The results were dramatic: by using a wing 40 percent smaller, the range of our glider system was increased from 4700 to 5600 nautical miles (Fig. 6). The L/D with the smaller wing was reduced about 14 percent, but this was far outweighed by the associated 4000 lb reduction in glider empty weight. I concluded that we should concentrate not on increasing L/D by every known means, but rather on seeking "optimized" configurations which generally would have much smaller wings than the high-L/D designs.

By the time of the Round III meeting we had also eliminated Love's high-drag tip cones - substituting toed-in tip fins - and thus making the range of our system with both improvements 6900 nautical miles, or more than 1000 miles greater than the claimed performance of the Ames' "high-L/D" design.

These results and other details of the Langley study were included in my summary talk at the first Round III session on October 16 (Ref. 13, 14). The ideas were accepted with little question.





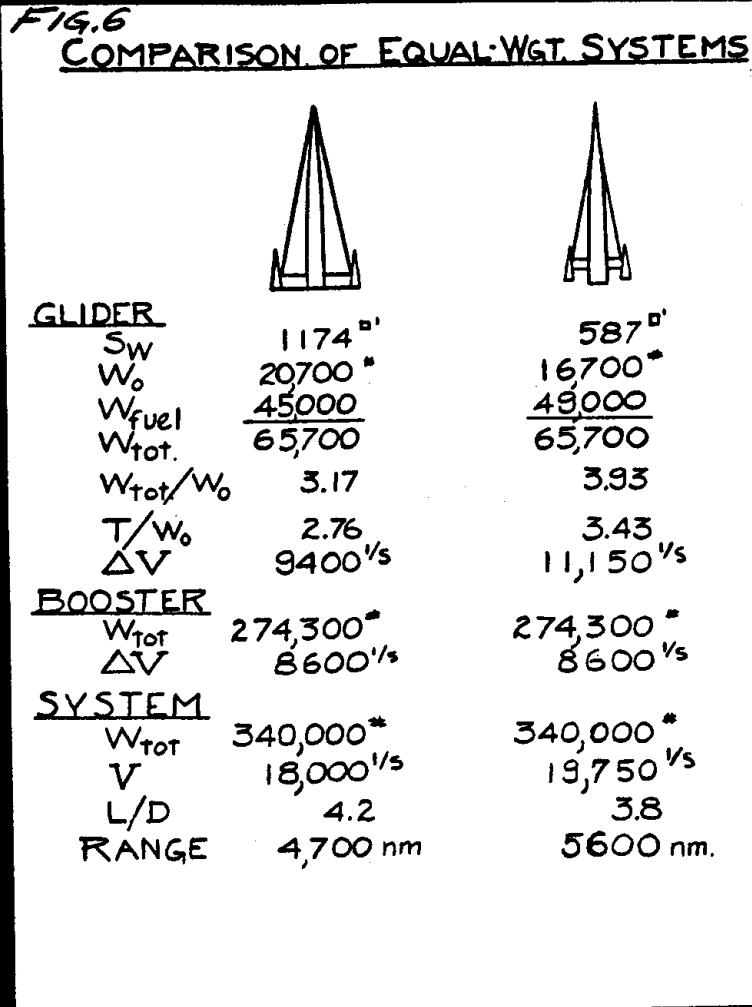


Fig. 6. Chart used in Round III summary talk by J.V. Becker showing how the Langley glider could achieve increased range by L/D reduction through use of a smaller wing, and emphasizing the need for optimization analyses of both the Ames and Langley vehicles. Ref 14.

Many of the Ames' people had begun to realize that design for very high L/D was fraught with enormous technical problems of heating and structural heat protection which had no easy practical solutions (Ref. 15). But a still more compelling new development of crisis proportions had captured the interest and imagination of all of us - Sputnik I was orbiting overhead. Now, only some 11 days after its launch, we all felt mounting pressures to come to grips with the problems of manned satellites, particularly the critical reentry problem. The Ames' view expressed by Eggers and others said in effect, "NACA should be working on the satellite reentry problem rather than on the HYWARDS sub-orbital gliders. Very low L/D should suffice for satellite reentry and this will make the technology much easier to develop than that for the gliders."

It should be noted here parenthetically that the ideas of pure ballistic and slightly-lifting wingless hypersonic vehicles did not emerge for the first time in NACA thinking at the Round III meeting as has been suggested (Ref. 15). "Lifting bodies" without wings had been studied since the early '50s by both Langley and Ames. It had been abundantly demonstrated in the prior ICBM developments that ballistic operation generally minimized the heat load problem, and it was equally well understood that the high decelerations of ballistic reentry could be greatly alleviated by small L/D, in the range achievable by blunt wing-less bodies (see for example Ref. 6 and This New Ocean). The new contribution of the Round III meeting was the NACA decision to take on satellite reentry as a major new challenge for research.

Ames also in effect said "We have lost interest in the sub-orbital glide systems and believe we should focus all of our R&D activities on satellite systems, for which we no longer need high L/D." The majority view expressed by I. H. Abbott of NACA HQ was that the satellite reentry problem for non-lifting or only

slightly-lifting vehicles should be studied, but as an addition to the boost-glide system rather than an alternate (Ref. 13). Notwithstanding this management dictum Ames terminated its hypersonic winged vehicle work shortly after the Round III meeting and devoted all of its energy to the low-L/D lifting capsule. Their hypersonic winged glider concept was left stranded in the early conceptual state indicated in Fig. 3, and they never moved ahead to winged reentry vehicles. In fact, as we will see later, they developed a strong antipathy to such vehicles. Thus, within NACA, it was left entirely up to Langley not only to pursue winged gliders and winged reentry vehicles technology, but also to provide the logic and the promotional support for winged systems.

Immediately after the first day of the Round III meeting I came down with the flu. Henry Reid and Pete Korycinski kept me informed of the later sessions at my bedside at the motel. I had plenty of time to reflect on Sputnik, which had been launched 12 days earlier and which was passing overhead periodically, announcing the advent of the Space Age. However, at that time the boost-glide sub-orbital system seemed much more immediate and more urgent from a military point of view than satellites either manned or unmanned. The Dyna-Soar project had been proposed by USAF/ARDC only two months earlier and would not be approved until the month after Round III, still specified as primarily aimed at boost-glide applications in spite of due consideration by USAF of the implications of Sputnik (Ref. 16).

At the same time my optimization study for Round III had convinced me that the "NACA Views" vehicles we had recommended were far too large and too complex for an effective new research airplane system. I resolved to take a fresh new look upon returning to Langley.

Langley Parametric Analysis of Glider and  
Reentry Vehicle Coolant Requirements

The most disturbing feature of the large boost-gliders proposed in the "NACA Views," by far, was the large weight of internal coolant they carried and the complex internal systems required to circulate the coolant to large surface areas. We all realized from the outset, of course, that the use of a circulating coolant was a highly undesirable complication, but our structures group saw no alternative pending the future development of a better high-temperature material, which at that time was often referred to as "unobtainium." The required coolant for each of NACA's hypersonic vehicles prior to 1958 had been determined on an ad hoc basis using the particular wing loading, skin temperature, etc., assumed for each case. It was clear by mid-1957, however, that the problem was of such controlling importance that a systematic, parametric analysis revealing the influences of the key variables was justified. P. F. Korycinski and I initiated such an analysis about two months prior to Round III. Exciting preliminary results were realized early in November 1957, and a final report of the work was published early in 1959 (Ref. 17). We found that skin temperature exercised an enormous overriding effect on the coolant required, which increased inversely with skin temperature raised to the 16th power! The conservative peak skin temperature for HYWARDS advocated by our structures group, 1800 degrees F., required very large coolant weights. However, a nominal rise in allowable temperature to 2200 degrees F., which was not beyond reasonable expectations for improved metallic or ceramic surface materials, completely eliminated the need for surface coolant except for the small-radii wing leading edges of the high-L/D gliders. That is, radiation from the hot wing surface would balance peak frictional heating for skin temperatures of 2200 degrees F. For global-range gliders or delta-wing reentry vehicles, which required maximum L/D's in the range of only 1 to 2, leading edge radii of the order

of 6 inches are permissible, and our analysis revealed especially interesting results for these winged vehicles, if they were designed to operate at high angles of attack approaching maximum wing lift in the peak-heating region of their glider or reentry trajectories: For a peak skin temperature of only 2000 degrees F. no coolant whatever was required. To achieve this result a flat-bottom wing large enough for a wing loading of the order of 20 lb per sq ft was required, operating near its hypersonic maximum lift coefficient of 1, at an angle of attack of about 45 degrees. This high-lift operation of course produced a high-altitude reentry trajectory - near the upper limit of the corridor for practical vehicles. Thus it was possible later on, in the Dyna-Soar project, to design the metallic DS-1 vehicle with zero skin coolant. And in the current winged Space Shuttles, which use advanced ceramic tiles capable of surface temperatures well in excess of 2000 degrees F., (Ref. 18), the same result is enjoyed with considerable relaxation of the wing loading and other limiting design variables.

After this study no further consideration was given to internally-cooled glide or winged reentry vehicles. The cumbersome and impractical vehicles advocated in the "NACA Views" were now obsolete and conveniently forgotten.

It should be recorded here that Glen Goodwin of Ames carried out a parametric analysis of glider cooling generally similar to ours, at about the same time. Neither of us had seen the other's study until we met to discuss possible papers for the forthcoming 1958 High-Speed Aerodynamics Conference. Goodwin proposed to give a summary paper, but Langley argued that a detailed discussion of cooling was now unnecessary since the real message of these studies was that cooling could be avoided for both long-range gliders and reentry vehicles. This all-important result could be treated in the papers dealing with the individual vehicle concepts. Thus, the Goodwin cooling paper was dropped from the

agenda, and to the best of my recollection the Ames' study was never published.

### Early Manned Satellite Vehicle Concepts

Pressures to develop technology for a manned satellite continued to grow and soon enveloped the military services and their contractors. USAF initiated studies of "Manned Ballistic Rockets" in 1956; initially sub-orbital missions were considered for comparison with the boost-glide system, but now (in the fall of 1957) the focus was shifted to the minimal orbital mission referred to as "Man-in-Space-Soonest" (MISS). At least 11 contractors studied as many concepts and we soon became aware of their problems by visits and calls from the company people involved.

In November of 1957 I made a first crude attempt to apply the results of our coolant study to the design of a minimal one-man satellite vehicle (Fig. 7). I selected only enough L/D (about 3/4) to insure low deceleration and nominal lateral maneuverability. The vehicle would be landed by parachute. Its wing loading, quasi-flat bottom and other features were chosen to permit metal skin temperatures no higher than 2000 degrees F at the peak heating point in its reentry, with zero internal coolant. John Stack took this sketch to a meeting of the High-Speed Aerodynamics Committee in November 1957. However, there is no evidence that he ever used it, and if reentry vehicles were discussed at all, it would probably have been in unrecorded pre-meeting discussions with the other NACA members.

By the time Stack had returned from his Committee meeting, I had found that for only a small increase in weight a far more attractive winged reentry vehicle could be achieved, one capable of much greater range control and conventional glide landing while still retaining the advantage of zero coolant. The general

Figure 7

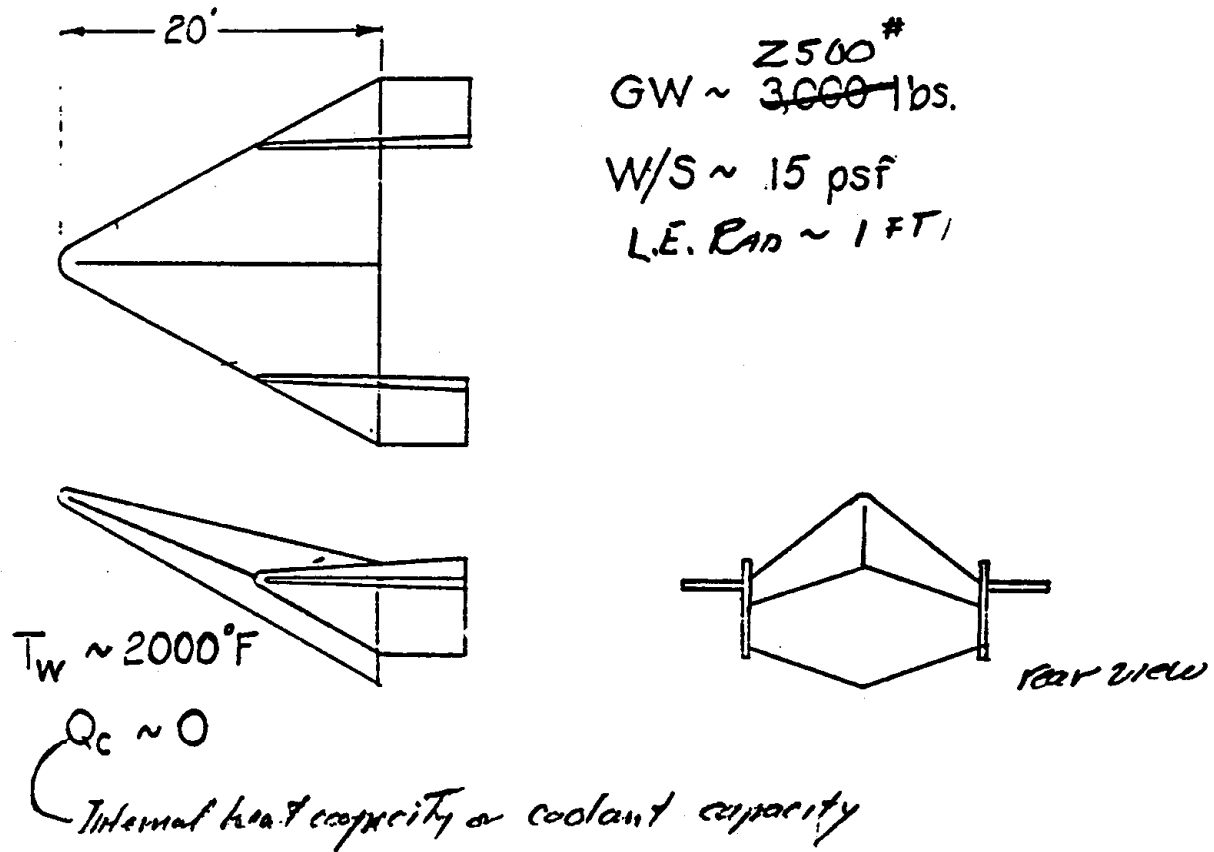


Fig. 7. Minimal manned reentry vehicle concept sketched for use of J. Stack in November, 1957. This was the first crude attempt to apply the ideas for eliminating internal coolant in a practical design using high-temperature metallic structure. See Ref. 17.

specifications for such a vehicle were stated and illustrated specifically in my paper on winged reentry vehicles given the following spring at the last NACA High Speed Conference, which will be covered later in these notes.











The early concepts developed by the 11 "MISS" contractors emerged in late January 1958 at an Air Force briefing which I was invited to attend. Figure 8, summarizing the concepts, is taken from my report of the meeting upon returning to Langley. Seven of the concepts were ballistic, with McDonnell showing a shape similar to what eventually became Mercury, obviously benefitting from their contacts with Faget. The four winged vehicles with L/D's ranging upward to 6 showed the general lack of understanding in the Industry at that time of how the winged hypersonic glider could be greatly simplified and its mode of operation altered to facilitate reentry. The Ames' concept of a blunt lifting half-cone with L/D of about 1/2 at this time was in its earliest formative stage - too early to have been utilized by the MISS contractors even if they had been interested in it.

Historians and lay readers should not be confused by the multiplicity of aircraft-like vehicle configurations appearing in the semi-technical literature of the '55 to '65 period under the general subject heading of "Space Transportation System Studies." Vehicles carrying hundreds of passengers and cargo to and from orbit were often depicted in detail by imaginative artists. The main interest of nearly all of these studies centered on the propulsion system and the "cost-per-pound-in-orbit" of operating the system. The enormous problems of reentry were not treated except for arbitrary and usually meaningless weight allowances for mythical "guidance and control" systems or equally non-existent "heat protection systems." Obviously none of these studies contributed anything towards solution of the reentry problem.



Fig 8

Fig. 8. The manned satellite vehicles proposed by Industry in USAF's "Man-in-Space-Soonest" study. Summary compiled at Contractor's presentations at WP-AFB in late January 1958.

	LOCK.	MARTIN	AERO-NEUT.	McDON.	AVCO	GOOD-YEAR	CONV'R	BELL	NAA	REPUB.	NORTH P
M.IN. MANNED SATELLITE									X-15B STRIPPED		
WGT. LB.	3000	3500	2545	2400	1500	2000	~1000	18,000	~10,000	4000	11,000
BOOSTER	ATLAS HUST.	TITAN	ATLAS + HUST.	ATLAS + POLARIS	TITAN	A or T + 3RD ST.	ATLAS + HUST.		4 G-26 + XLR-44	ATLAS + POLARIS	
ORBIT	150-300 3 REV	150 m. ~1 DAY	-	100 m. 1 REV.	120 m. 1 WEEK	200-400 5 DAYS	170 mi -	A STUNT	-	100-150 few REV.	
* TRACKING	←			"MINI TRACK" SYST.							→
* ORBIT CONTROL	RETRO. $\Delta V=200$ FT/SEC	RETRO. $\Delta V=500$ 1/5	RETRO.	RETRO.	VAR. DRAG	RETRO. $\Delta V=800$ 1/5	RETRO. $\Delta V$		VARY L/D	$\Delta V=65$ + VAR. LD	
ATTITUDE CONTROL	ROCKET EL. MOTOR	ROCKET	-	ROCKET	CHUTE	-	-		ROCKET PILOT	ROCKET	
PILOT FUNCTIONS	NONE	NONE	NONE	NONE	NONE	NONE	?		FLY AIRP.	MONITOR	
MAX. DECEL.	~8g	8-15g	-	8.5g	7-9g	-	-		-	"low"	
STRUCT. TYPE	ABLATION OR BERYL	ABLAT.	GRAPHITE HT. SHIELD	HT. SINK (BERYL)	RADIATION (MOLY or IN)	ABLAT.	-		BE0 + RENE 41	INCONEL	
SAFETY	EJECT CAPSULE AT LAUNCH	EJECT AT LAUNCH	EJECT AT LAUNCH	POLARIS + CHUTE	EJECT TO 3000, CHUTE	EJECT AT LAUNCH	-		?	-	
W/C <sub>0</sub> A %/SQFT	100	100	61	60	1.5	50	50	"DYNASOAR" "WINGLESS WOULD BE ONLY A STUNT"	W/S-50	W/S-26	"DYNASOAR" APPROACH
LANDING AREA, MI.	400 x 20	100 x 100	100 x 50	400 x 400	"KANSAS" 400 x 200	800 DIA	-		-	-	
TIME TO MANNED FLT.	2 YR.	2 1/2 YR	6 YR	2 YR	2 1/2 YR	2 YR	1 YR	5 YR	2 1/2 YR	1 3/4 YR	-
COST, MILLIONS	10-100	-	-	-	40	100		889	120 (3 ARR)		

\* All non-winged designs use zero-C<sub>L</sub> reentry with no flight path control. Winged designs have complex ground controlled systems monitored by pilot.

1120/MB

Of greater significance were a number of unconventional reentry schemes that appeared in the years following Sputnik. Most of these attempted to alleviate the reentry heating problem by using extremely low wingloadings or, in the case of ballistic designs, very low disc loadings, i.e., very large surface areas which permitted higher attitude reentry trajectories. These schemes included inflatables, erectable kite-like arrangements, and a variety of other variable-geometry inventions. More often than not the heating problems were treated inadequately. Some of the more interesting schemes are depicted and assessed in Ref. 19 and 20. None ever materialized in any actual application.

#### John Stack's Attitude Towards Space Projects

It should be noted parenthetically that Stack was not really much interested in the reentry problem or in space flight in general. The X-15 promotion was the only space-related project that he clearly supported in the '50s, to the best of my recollection, but even so with only a semblance of the notorious promotional fire he could generate if he was really interested. His main enthusiasms in the '50s were the SST and advanced military aircraft. To a degree he seemed to have developed a hostile, adversary attitude towards space, perhaps because it threatened to drain resources that otherwise might belong in aeronautics. When the Apollo project was established, he sneeringly told me, "I don't buy this 'to the Moon by noon' stuff." Noting the enormous sizes of the rocket boosters ("like the Washington Monument"), he sided with the abortive early attempts to find viable air-breathing aircraft-like launch systems. After leaving NASA and going to Republic, he continued to favor advanced aircraft as opposed to Space projects. All of the developments discussed in the present document, i.e., X-15, HYWARDS, Round III, Dyna-Soar, the Langley reentry concepts, etc., took place with little or no technical or managerial inputs from Stack. Most of them were under the aegis of

Hartley A. Soule - who wore a NACA HQ hat labeled "Research Airplane Projects Leader." However, this fact would never have deterred Stack from all-out participation if he had been interested.

For one with his previous record in the forefront of high-speed aircraft developments, Stack's decision to remain in the aeronautical camp and glare at the dramatic space developments as they were accomplished by others is one of the most curious personal enigmas in NACA history.

The Last NACA Conference on High-Speed Aerodynamics,  
March 18-20, 1958

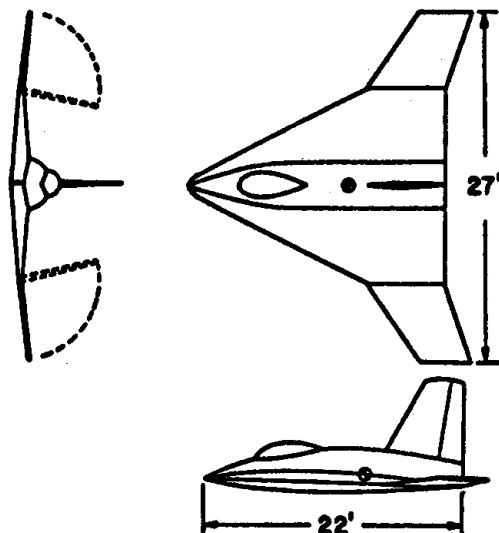
Since the mid-1940s NACA's periodic conferences on High Speed Aerodynamics had successfully high-lighted the agency's most advanced research in aeronautics for Industry-wide audiences of as many as 500 specialists. This final meeting under the NACA banner focused principally on manned satellites; vehicle concepts and supporting technology. Any historian who doubts NACA's virility in its last days or its ability to respond quickly, fulfilling both advisory and research functions in a truly outstanding way, should read the Conference document (Ref. 21) and interview a sampling of those who attended.

As originally planned at a meeting in NACA headquarters on December 16, 1957, the agenda did not include any papers dealing explicitly with reentry vehicle concepts. Supporting technology was included in several papers to be given on the second day. Some of Max Faget's work with the ballistic concept was mentioned, but it was buried in a general discussion of operational problems. Following traditional NACA policy to the effect that the development of aircraft designs was properly the province of Industry, nothing else was to be said about vehicle concepts.

The week following this HQ meeting, one of the contractors responding to USAF's "Man-in-Space Soonest" study visited me to discuss his candidate reentry vehicle, an  $L/D \sim 6$  winged glider, forcefully impressing on me the need for NACA to discuss winged reentry vehicle concepts at the forthcoming conference. Right after the holidays I called on Bob Gilruth, who was coordinating the Langley papers, with a proposal to prepare such a paper. He was in full agreement, and he pointed out that Faget's study also deserved to be a separate paper. Not to be outdone, Ames then proposed to add a paper covering their  $L/D \sim 1/2$  half-cone approach. These three conceptual vehicle papers were programmed for the first session, immediately following Chapman's analytical study of reentry mechanics and heating.

My paper on the winged concept opened with a brief discussion of the general unsuitability of high- $L/D$  gliders as reentry vehicles.  $L/D$ s in the range 1 to 2 were shown to be adequate for both g-alleviation and range control. A general comparison of the relative heating of lifting and non-lifting reentry emphasized the large reduction in both heating rates and heating loads made possible by low  $L/D$ , high-lift operation of winged vehicles. Included in the comparisons was the case of a conventionally-shaped fighter-type aircraft reentering at 90-degree angle of attack, i.e., as a non-lifting or ballistic vehicle which converted to conventional flight for low-speed range and landing. This mode of operation, feasible in principle, did not appeal to me because it retained most of the crudities of ballistic vehicles and sacrificed the advantages of lift, except for approach and landing. Nevertheless I included this concept (top of Fig. 9) for the sake of completeness and out of deference to my friends in the Flight Research Division, some of whom were interested in it. The paper concluded with the small configuration (bottom of Fig. 9) which embodied all of the features we now advocated on the basis of our

### HIGH-DRAG RE-ENTRY CONFIGURATION



### HIGH-LIFT-GLIDE RE-ENTRY CONFIGURATION

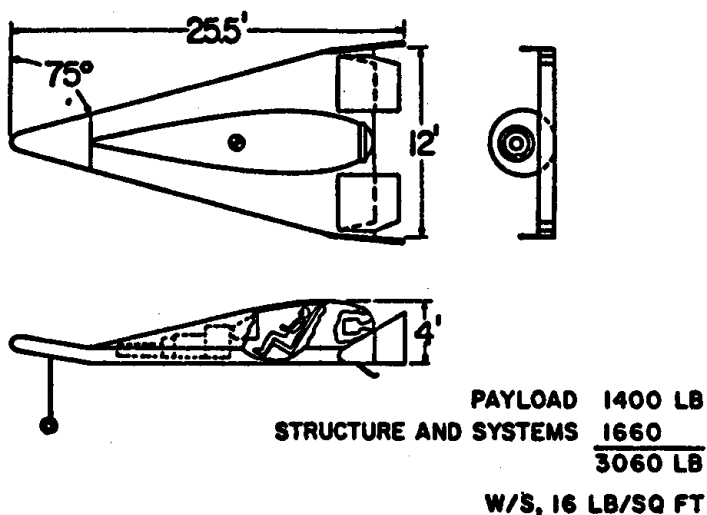


Fig.9. Conceptual winged reentry vehicles discussed in Fig.10 of paper No.4 of Ref.19. The lower design embodies all of the Langley-developed features for minimizing heating and allowing metallic structures with zero coolant.(Ref.17)

HYWARDS work and our coolant study: L/D in the range 1 to 2 for range control, hypersonic maneuvering, and inherent capability for conventional glide-landing; radiative solution of the heating problem by operation near maximum wing lift; use of large leading edge radii, flat-bottom wing, and fuselage located in the protected lee side of the wing. Roger A. Anderson of the Structures Division provided the structural design and weight estimates for this minimal winged satellite, and Eugene S. Love assisted with the aerodynamic layout. The estimated all-up weight was 3060 lb, only about 1000 lb more than the minimal ballistic capsule.

This paper created more industry reaction - almost all of it favorable - than any other I had written. If we had had a more energetic booster than Atlas at that time, the first U.S. manned satellite might well have been a landable winged vehicle.

#### Project Dyna-Soar

The source evaluation and selection activities for the Dyna-Soar research and test vehicle (DS-1) afforded major opportunities in the spring of 1958 for NACA to influence the program and the vehicle concept. In broad terms the declared intent of DS-1 was "to research the characteristics and problems of flight in the boost-glide flight regime up to and including orbital flight." We in NACA thought of DS-1 as a follow-on X-15, covering the speed range from Mach 7 to near-orbital speed. I had been appointed NACA Co-chairman, Scientific and Technical Area, serving with my opposite number, USAF's W. E. Lamar, who also headed the entire evaluation exercise. I found Lamar to be a shrewd, able, effective manager. We soon developed an excellent rapport and exercised a controlling influence on the outcome of the evaluation.

Our background experiences with X-15, HYWARDS, Round III, and the winged reentry vehicle study had established in my mind very

clear desirable guidelines for the DS-1 vehicle which were now quite different from the official "NACA Views" of Ref. 12. In the NACA/USAF meeting of the source evaluation groups in late March at Wright-Patterson AFB I put forward the following ideas relating to DS-1:

1. Instead of the large high-L/D, structurally complex, water-cooled glider recommended in the NACA HYWARDS study of 1957, DS-1 should be a small L/D~2, relatively simple, radiation-cooled vehicle. Such a small simple vehicle could be procured much more quickly, with less risk, and would greatly ease the booster problem.

2. A DS-1 vehicle in the L/D~2 category would serve equally as an advanced prototype for the semi-global-to-global-range, boost-glide system (for which low L/D is actually preferable) and for the future maneuverable, landable, space reentry system (for which L/D~2 is also the likely category). Research-wise this class of vehicle would be more valuable than the high-L/D glider which was applicable only to glide ranges of the order of 1/4-global.

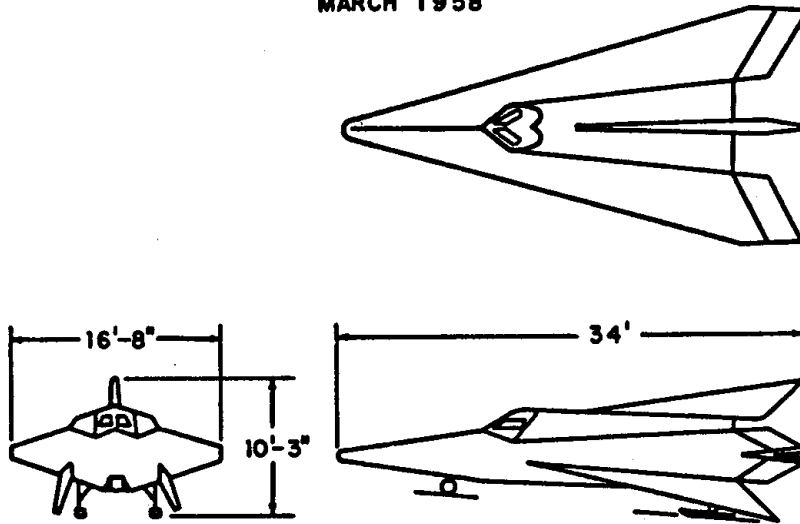
There were two problems with my new views: they had no official status in NACA as yet, and they were at variance to the boost-glide work statement to which the contractors would be responding in the present source selection exercise. Nevertheless these views were discussed with great interest by many of the USAF and NACA members of the evaluation groups and they apparently had an effect on the outcome of the evaluation.

Of the nine contractors bidding on DS-1, only one offered a small vehicle in the L/D~2 category. Boeing's design, however, was charged with several flaws (top of Fig. 10): their use of features which aggravated heating and their too-optimistic heating estimates, among others. Martin and Bell had teamed to submit a





**GENERAL ARRANGEMENT**  
MARCH 1958



**GENERAL ARRANGEMENT**  
APRIL 1959

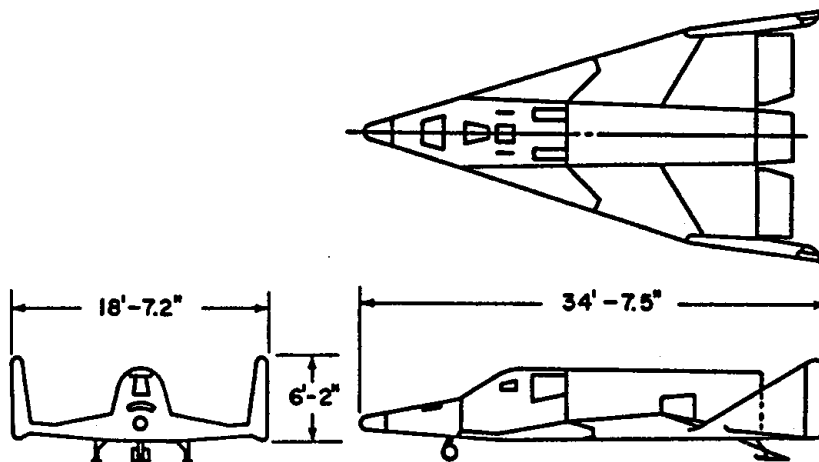


Fig.10. Charts No.4 and 8 of Boeing paper by R. Rotelli in Ref.21 showing the changes in their Dyna-Soar configuration from their original proposal of March, 1958 to the design of April, 1959 which incorporates all of the major alterations proposed by the Government on the basis of the NACA/NASA recommendations of Ref.19.

higher-L/D mid-wing design. Their proposal, overall, was rated close to Boeing's primarily because of Bell's obvious depth of experience in hot structures, acquired in their previous boost-glide studies. USAF decided on June 16, 1958 to accept the recommendations of the Source Selection Board to continue both Boeing and Martin/Bell in a Phase I competition for the ensuing nine months during which revised and improved designs would be advanced to the mock-up stage. Both teams were briefed on the new design features now recommended by the NACA/USAF DS-1 group.

Boeing's Phase I efforts produced an entirely new design incorporating all of the government recommendations in a wholly satisfactory way (Bottom sketch of Fig. 10). Their new L/D 2 vehicle had a flat-bottom wing, nose tilt for trim, toed-in tip fins, fuselage on the upper surface of the wing in the protected "hypersonic shadow" at reentry attitudes, large leading-edge radii, and radiation-cooled structure with no internal surface coolant. Martin/Bell developed a still lower-L/D vehicle with somewhat similar other features. Figure 11 is the free-hand chart used during the Phase I design evaluations in April 1959 to compare the glide corridors and associated research aspects of the two vehicles - Boeing having the edge here with a broader meaningful corridor exploration potential. In all other respects except propulsion Boeing was judged the more desirable system. Martin, however, was continued as the booster developer, primarily because of their involvement with the Titan.

At this stage DS-1 seemed to be everything that NASA desired. This, we believed, was the research airplane that would extend the flight spectrum from the X-15's Mach 7 on up to orbital speed, and the research data would be equally applicable to boost-glide and sophisticated reentry systems. NASA top management had readily accepted the drastic changes in the configuration described above; however, they never formally repudiated the large high-L/D water-cooled gliders advocated in the NACA-Views (Ref. 12).

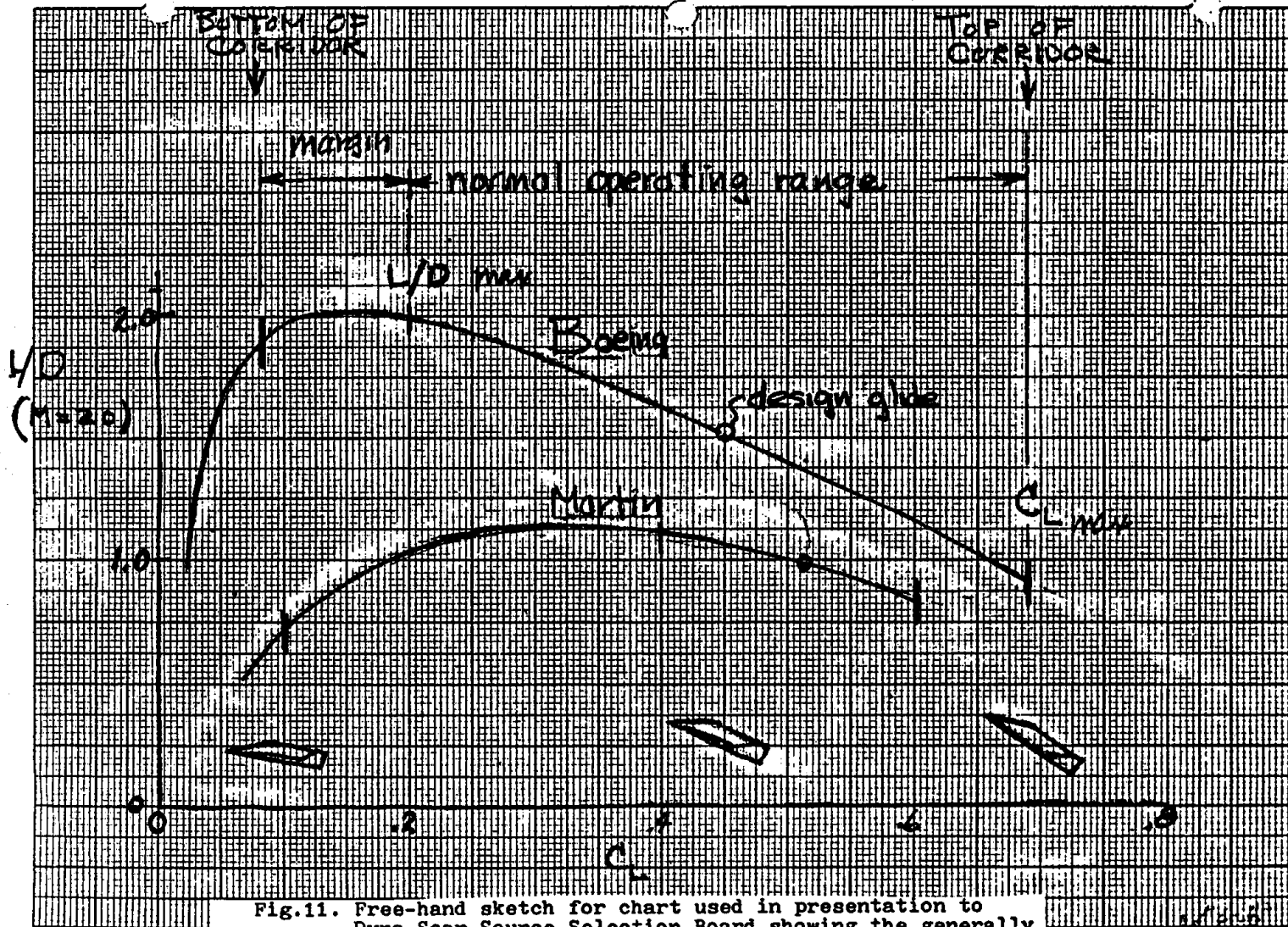


Fig. 11. Free-hand sketch for chart used in presentation to Dyna-Soar Source Selection Board showing the generally broader capabilities of the Boeing glider for corridor exploration.

Several of Langley's research divisions became heavily committed to supporting projects bearing on the prime development problems of Dyna-Soar. The contractor negotiated directly with appropriate Langley staff members for wind tunnel and other testing and then cleared the plans with the Dyna-Soar project office at Wright-Patterson AFB. My long-time colleague, P. F. Korycinski, had been assigned to the project office as NASA's official representative, and he was effective in expediting the support work. In the next three years some 3900 hours of wind tunnel testing (NASA-wide) were accomplished throughout the broad speed range of DS-1. Unnumbered additional hours were devoted to testing in specialized facilities related to problems in hot structures, landing system, dynamic loads, panel flutter, noise, heat transfer, communications through the plasma sheath during reentry and others. Analytical and theoretical work essential to these experimental projects absorbed added prime manpower. Much of the fruit of these programs was, of course, of specific use primarily to Dyna-Soar; but a significant part proved of general fundamental value and was reported in general research papers. Reference 20 contains a substantial sampling of the results in hand by April 1960, two years after the initial source selection.

It is desirable at this point to identify the principal Langley individuals who contributed to Dyna-Soar. Starting at the top, F. L. Thompson provided relaxed, shrewd general management which allowed great freedom at the divisional and project levels. His assistant, Hartley A. Soule', who also served as Research Airplane Projects Leader for NASA Headquarters, handled effectively the day-to-day top management of Dyna-Soar. When Stack moved up to his Washington office position in 1959, he was succeeded by Lawrence K. Loftin, Jr. as an assistant to Thompson. Unlike Stack, Loftin showed much interest in Dyna-Soar and he participated in the front-office activities along with Thompson and Soule'. As Chief of the Aerophysics research division where a major part of the Langley

support work for DS-1 was centered, I was naturally involved in all phases of the program. I was often also called upon to be the technical spokesman for the entire Langley program, although no formal anointing for this function was ever made.

Following is a list of the principal Langley contributors to winged reentry vehicle technology in the 1958-1963 period. These are individuals shown by their publications or other evidence to have made noteworthy personal technical contributions. I am aware of the hazards in setting up such a list. If there are any omissions, in spite of the care I have taken to include everyone, I offer my apologies.

Principal Langley Contributors to Winged Reentry  
Vehicle Technology, 1958-1963

Hypersonic aerodynamics, configuration, stability and control

M. H. Bertram  
M. Cooper  
D. E. Fetterman  
A. Henderson, Jr.  
E. S. Love  
C. H. McLellan  
M. Moul  
J. A. Penland  
W. H. Phillips  
R. W. Rainey  
L. Sternfield

Heat transfer

I. E. Beckwith  
J. C. Dunavant

W. V. Feller

P. F. Korycinski

Aeroelasticity, dynamic loads, panel flutter, launch vehicle dynamics, landing system dynamics, noise

S. A. Batterson

L. D. Guy

J. C. Houbolt

H. H. Hubbard

U. T. Joyner

H. G. Morgan

A. G. Rainey

H. L. Runyan

Low-speed flight characteristics

D. E. Hewes

J. R. Paulson

R. E. Shanks

Trajectory analysis

F. C., Grant

Reentry communications (blackout problem)

J. Burleck

M. C. Ellis

W. L. Grantham

P. W. Huber

R. A. Hord

D. E. McIver, Jr.

T. E. Sims

Hot Structures, materials

M. S. Anderson  
R. A. Anderson  
W. A. Brooks, Jr.  
L. R. Jackson  
E. E. Mathauser  
R. A. Pride  
R. T. Swann

Doubts about Dyna-Soar first began to surface during the summer of '59. To many Air Force R&D specialists, the growing prospects of military operations in space were more exciting than boost-glide operations in the atmosphere. I learned firsthand from my USAF contacts of another disturbing point of view--said to be shared by General Schriever--to the effect that NASA's Project Mercury was believed likely to fail, making it necessary for USAF to put the first American in orbit. This reasoning was based partly on the Vanguard fiasco, and partly on Schriever's alleged belief that NASA's use of ex-researchers to manage Mercury was a mistake. Researchers supposedly were inept at management and operations. USAF, on the other hand, would succeed because of their BMD know-how and experience. In the event of such a USAF takeover, Dyna-Soar would be the candidate vehicle for the first manned orbital flight, and as such should it be a sophisticated winged system or a simpler semi-ballistic system that would be quicker to develop and perhaps more reliable?

J. Charyk, Assistant Secretary, had become a believer in USAF's future in space and he was influential in instituting the so-called "Phase Alpha" study in November 1959 at about the same time that formal USAF approval for DS-1 was obtained. Phase Alpha asked the DS team in effect to "take another broad look and see if you really want a winged vehicle or whether you can do better with a ballistic

or slightly-lifting type." The intent here, was clear: if another type of system could be shown to have important advantages, DS would be re-directed and everything that had been done to support winged system technology would be set aside. Probably there would be no manned explorations of the glide corridor in the Mach 7 to orbital speed range.

USAF space advocates had found an important ally within NASA. Since the Round III meeting where he had proposed to work exclusively on slightly-lifting capsule-type reentry vehicles, A. J. Eggers, Jr., had been cultivating a growing personal distaste for winged reentry vehicles. As he saw it, the problem of placing sizable payloads in space was aggravated by having to cope with the added weight of wings - especially with the marginal boosters then available. What about lateral range, hypersonic maneuvering, conventional landing, etc.? His answer was "If USAF has a real reason for boost-glide or maneuvering reentry and conventional landing--OK. But, if what they really want is the maximum possible payload in space, then they should use a simple light-weight semi-ballistic reentry system." He spread this doctrine very effectively and it doubtlessly contributed to USAF's decision to proceed with "Phase Alpha." As a member of the Aero and Space Vehicles Panel of the SAB, Eggers had many opportunities to hammer away against winged reentry configurations.

#### SAB Review of Dyna-Soar and "Phase Alpha"

The five members of the Aero and Space Vehicles Panel and eleven consultants, mostly from industry, met at Ames Research Center for three days, December 2-4, 1959, for this review. They listened to presentations by the DS project office and by NASA. Those of us involved in the project believed that a major threat to our L/D~2 winged system existed, and we anticipated that Eggers might attempt to strike a mortal blow.



Realizing that his  $L/D \sim 1/2$  blunt half-cone reentry vehicle candidate was not likely to find a sponsor now that Faget's ballistic shape had been selected for Mercury, Eggers had recently proposed a more slender half cone the "M-2" which had an  $L/D$  of about 1, and which might conceivably be landable as a glider (Ref. 23). Its great selling point in his mind of course was that it was "wingless," a "lifting body"--even though its planform was about the same as the DS, as it would have to be if there were any hope of achieving necessary low-speed handling characteristics. In anticipation that we might hear the propoganda for M-2, I built my presentation around Fig. 12 which compared two half-cone bodies ( $L/D \sim 1.5$ ) with a DS-type wing-body of the same planform and aspect ratio ( $L/D \sim 2$ ). We knew from low-speed testing that the wing-body shape could develop an  $L/D$  as great as 5 for low-speed approach, while the half cones would certainly have lower (then unknown) low-speed performance, perhaps about  $L/D \sim 3$ . Thus the main virtue of the half-cones, bought at sacrifices in  $L/D$ , would be increased body volume--a useless feature in Dyna-Soar which had more than enough fuselage volume for its anticipated payloads.

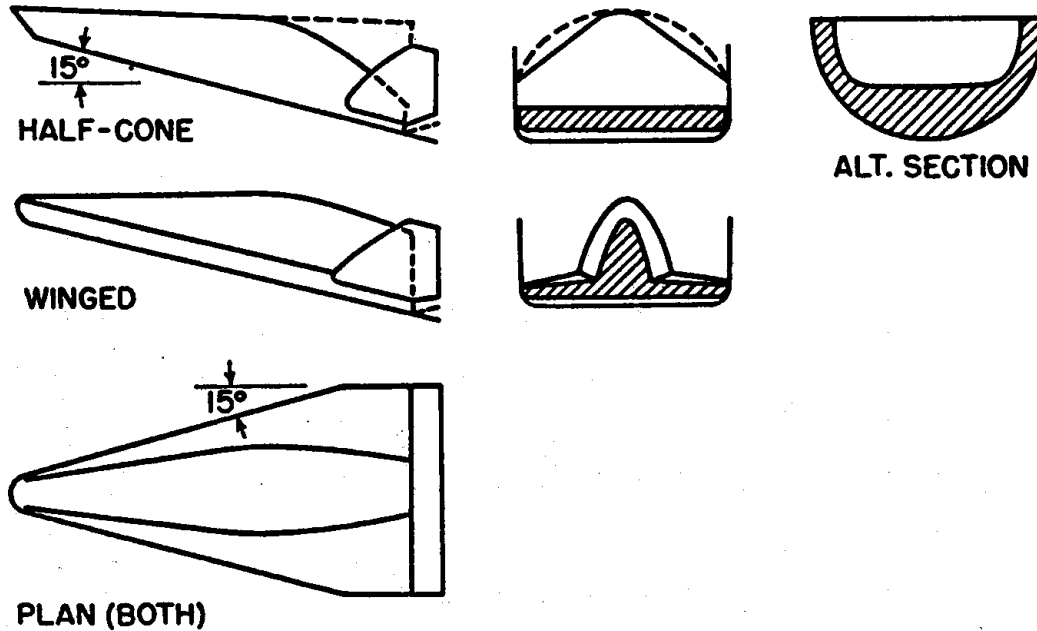
I closed my presentation with a review of the impressive benefits achievable by a winged vehicle in the  $L/D \sim 2$  range as covered in my 1958 conference paper, reminding the SAB that the sophisticated performance of these winged vehicles involved only a nominal weight increment of the order of  $1/3$  over comparable ballistic systems. This modest increment would certainly be tolerable as booster capacity advanced beyond the Atlas which was the limiting factor in selecting the small ballistic capsule for Mercury.

We were gratified when a large majority of the consultants agreed with the choice of  $L/D \sim 2$  as the proper goal for DS, and this was underscored in the Panel's report (Ref. 24) which said " $L/D$  of the order of 2 is considered correct." In the executive session



CONFIGURATIONS FOR  $\left(\frac{L}{D}\right)_{MAX} \sim 1.5 \text{ TO } 2.0$

(SUBSONIC  $\left(\frac{L}{D}\right)_{MAX} \sim 5$ )



NASA

L-1354-8

BECKER 12-2-59

Fig.12. Chart used in NASA presentation at SAB meeting of Dec.2-4 to compare the conceptual Dyna-Soar wing-body with comparable lifting bodies of the same platform. Data were available for wing-bodies indicating  $L/D$  2, hypersonic, and 5, subsonic. The lesser performance of the lifting bodies was estimated as approximately  $L/D$  1.5, hypersonic, and 3, subsonic.

held on Saturday, December 5, Chairman C. D. Perkins stated at the outset that Dyna-Soar at this point was "easily killable," that USAF wanted Dyna-Soar, and that "SAB should help USAF." Perhaps because of this admonition, Eggers was quieter than usual and did not attempt a hard-sell of the M-1 or M-2 at this meeting.

The Panel was concerned about the adequacy of advanced technology in several areas of DS-1 design and they suggested that Phase Alpha, rather than being a "do better" exercise should concentrate on program planning to raise the confidence level. This suggestion was disregarded in the ensuing Phase Alpha study (Ref. 20) which turned out to be largely a comparison of alternate vehicle systems. However, the ground rules laid down by the Project Office were such that only a winged L/D~2 system could possibly meet all the requirements, and thus Phase Alpha was pretty much wasted effort though it did produce some valuable comparative weight analyses. Overall, however, it appeared to be a gesture to upper management. When the Panel met again on March 28-30, 1960 they were provided with a massive review of supporting technology, much of the key material that had been prepared for the forthcoming USAF/NASA Conference on Lifting Manned Hypervelocity and Reentry Vehicles (Ref. 20). The Panel was generally satisfied regarding the adequacy of technology to support DS-1. Significantly, however, at the end of their report (of April 15, 1960) they inserted the following statement at Eggers' instigation:

" . . . if the overriding requirement were to get large payloads in orbit as soon as possible . . . the (L/D 1/4 to 1/2) vehicle class might well be preferred . . . the Panel did want to be sure that the Air Force was aware . . . of this alternate . . . ."

## Rocket-Model Flight Tests Supporting DS-1

After the SAB meeting of December 1959, I was convinced of the political desirability if not of the technical necessity for a high-priority attempt to obtain flight tests data to validate questionable DS wind tunnel results in certain critical heating and aerodynamic areas. The attempts within NASA to extend the Wallops Island rocket technique to Mach 15 or higher had proved disappointing. From the standpoint of setting new PARD speed records these flights were a success (See NASA Ref. Publ 1028), but a careful review of results presented in NACA/NASA conferences shows the technical contributions to be disappointing; the flights were always subject to rapidly changing velocity and altitude conditions, little or no structural data were obtained, and the models were not recovered.

I had recently learned from colleagues on the NASA Missile and Spacecraft Aerodynamics Committee of the possibility of attaching "hitch-hike" or "piggy-back" tests to recoverable USAF/BMD RVX-2 nose-cones. (The RVX was the first ablation-protected ICBM nose cone recovered after a long-range flight over the Atlantic in May 1958). Scheduled future flights would be Atlas-boosted to reentry speeds of about Mach 22: ideal for the critical heating and aerodynamic tests that we needed. To explore this possibility I traveled to BMD and STL headquarters in Los Angeles on February 19, 1960. George Solomon and his cohorts thought our type of add-on aerodynamic test would be feasible and urged me to proceed. Accordingly, we organized an ad hoc design group under C. H. McLellan which came up with the rather unlikely constellation of test models arrayed about the RVX-2 shown in Fig. 13. About half of the proposed tests related specifically to the DS-1 configuration; the rest were more general experiments. It was not difficult to convince the DS project office to fund this RVX-2 payload in the DS development program in August of 1960. BMD, of



**ADVANCED FLIGHT EXPERIMENTS IN  
HYPERSONIC AERODYNAMICS AND HEATING**

Figure 13

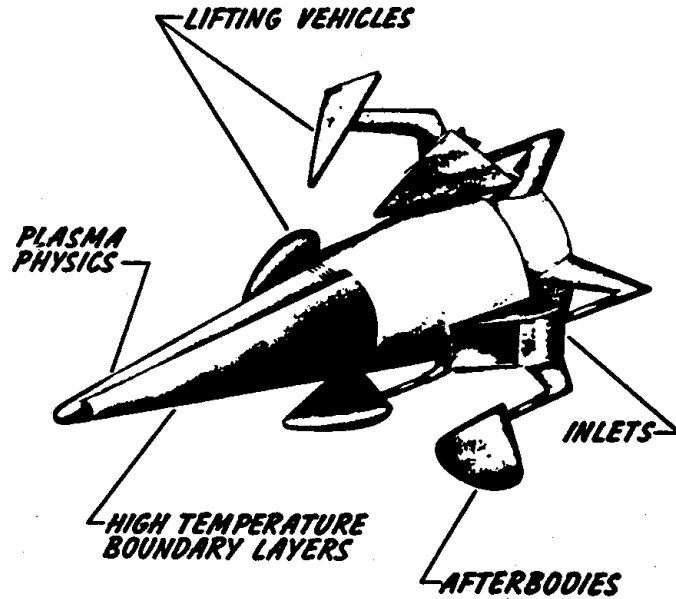


Fig.13. The proposed RVX-2 aerodynamics/heating payload configuration developed by C.H.McLellan's Langley group in 1961.

course, was funding the booster. NASA/Langley agreed to provide the engineering and the instrumentation for the payload.

Another rocket test vehicle system useful to DS-1 was already under preliminary consideration in 1960 by the structures and materials groups in USAF's Flight Dynamics Lab. ASSET (Aerothermodynamic/elastic Structural Systems Environmental Tests). In the curiously detached and indifferent way in which major subdivisions of the giant bureaucracies often ignore each other, FDL's vague and all-encompassing project description for ASSET made no mention of X-15, DS, ground facilities, or other important interrelationships. Figure 14 is the Langley chart used to clarify the situation (the "proposed NASA experiment" is the RVX-2).

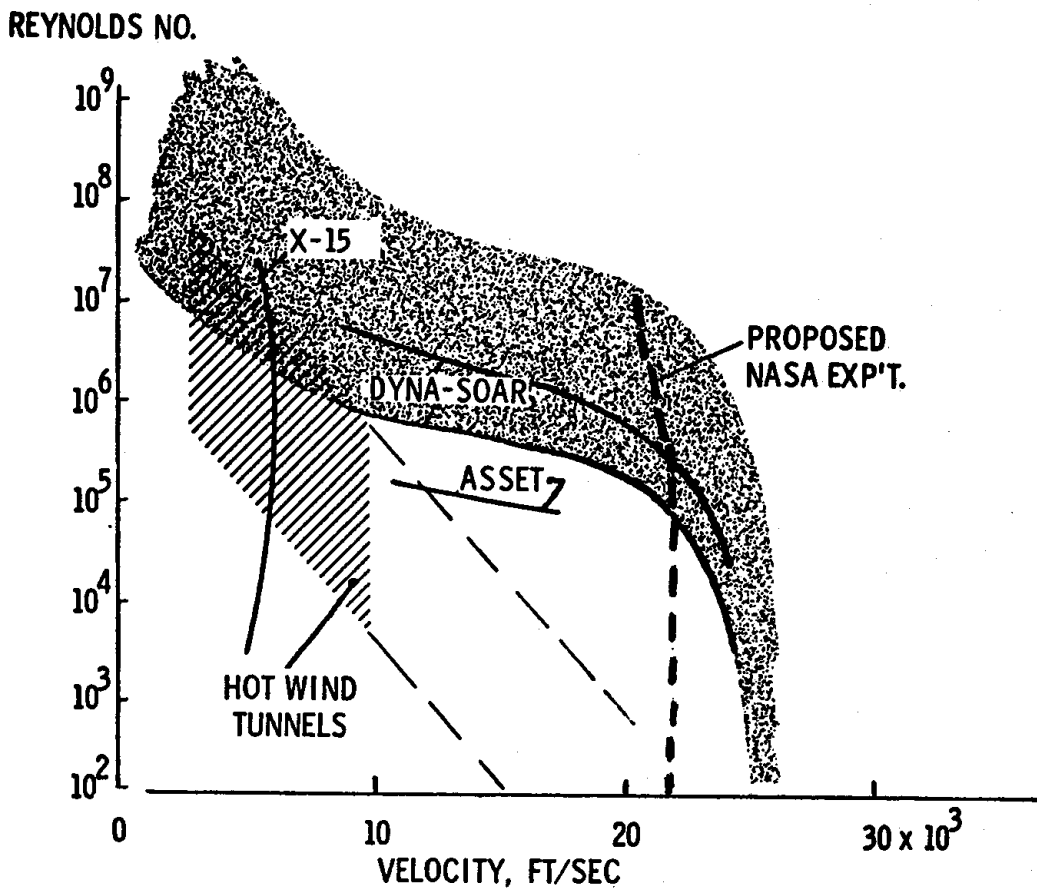
Thus by 1961 two complementary sets of unmanned flight tests important for Dyna-Soar were in active preparation: RVX-2 and ASSET.

#### The Decline and Termination of Dyna-Soar

NASA's influential involvement with Dyna-Soar came to an abrupt end in 1961. It was probably no coincidence that this decline started soon after General Schriever's accession as head of ARDC. The charts used by Soulé, Becker, Korycinski, and others of NASA's Dyna-Soar Team to describe this situation to Administrator Webb on January 4, 1962 are shown in Figs. 15, 16, and 17. W. E. Lamar had rather apologetically informed us during the fall of 1961 of the drastic re-direction that was to be implemented in December 1961, without any participation or consultation with NASA. The series of sub-orbital manned flights down the Atlantic missile range at progressively increasing speeds, which constituted the "research airplane"--type of exploration of the boost-glide and the reentry corridor of prime interest to NASA, was entirely eliminated. Now in the interests of economy, and perhaps following the lead of



## LIFTING VEHICLE TECHNOLOGY



L-1585

Fig.14. Environmental comparisons for the RVX-2, other flight test systems, and ground-based facilities.



**NASA PARTICIPATION IN DYNA SOAR**  
**APRIL '58 to JAN '61**

**PERIOD OF JANUARY 1961**  
**TO DECEMBER 1961**

- Apr. 1958 Evaluation
- Dec. 1958 SAB review
- Apr. 1959 Evaluation
- Dec. 1959 SAB review
- Jan. 1960 Phase Alpha study
- Mar. 1960 SAB review
- Apr. 1960 DS conference
- Aug. 1960 RVX-2 added to DS
- Nov. 1960 DS-NASA plan for RVX-2
- Dec. 1960 SAB review

*Heavy  
 NASA  
 participation*

- Studies of space operations of DS (Rendezvous, multiple orbits, etc.)
- Aerospace Corp. studies of new DS configurations, structural approaches, etc.
- Formal evaluations of above concepts
- Project "Streamline" study and evaluations thereof
- Study of Mercury Mark II as substitute for DS
- Booster studies
- Selection of Titan III Booster
- Two SAB reviews of above studies
- Abandonment of step approach
- Removal of RVX-2 from DS

*No  
 NASA  
 Participation*

Fig. 15. Charts used in Dyna-Soar briefing of Jan. 4, 1962 for NASA Administrators Webb, Dryden, and Seaman. (a) period up to Jan. 1961.

15(b) 1961 to 1962.

Figures 15 (a) and 15 (b)

**MANAGEMENT SUMMARY**

**TECHNICAL SUMMARY**

1. NASA support to DS currently involves about 55 personnel continuously
2. NASA has utilized its wind tunnels for DS for 3900 hrs
3. Although the AF is considering a fundamental redirection of the program, the working level has to continue under the current directive; AF asks NASA for support in areas of tests that will probably be abandoned
4. AF has essentially eliminated NASA from policy decisions

1. Exploitation of winged-configurations is an essential part of a balanced space program.
2. Deletion of build-up flights to 22,000 fps from the DS program increases the risk of failure.
3. The RVX model tests should remain in the program.
4. Saturn is the only booster system that would give DS orbital capabilities by 1964.

6-1081

6-1000

Fig. 16. Presentation of Jan. 4, 1962. Management Summary

Fig. 17. Presentation of Jan. 4, 1962. Technical Summary.

Figure 16

Figure 17

Project Mercury, only two unmanned sub-orbital flights would be made, from Cape Canaveral to Edwards, prior to similar sub-orbital manned flights, and orbital flights.

USAF also canceled their support for our RVX-2, a relatively minor but for us a particularly unpleasant act. (We subsequently made a rather half-hearted and unsuccessful attempt to continue RVX-2 under NASA funding). As far as our NASA DS team was concerned, Dyna-Soar as a research airplane was dead.

During the remaining two years of Dyna-Soar's existence NASA continued as a largely inactive nominal partner, completing the tests to which we were committed. It was now obvious that USAF was interested in DS only as a prototype of an orbital system and not as a research vehicle. Whatever R&D aspects might be involved could be treated in lesser unmanned programs like ASSET or START, according to their philosophy. As time went on it also became increasingly apparent that USAF did not have a clear believable vision of what their orbital system requirements really were, and thus doubts increased as to whether DS-1 was an appropriate development vehicle. The fact that DS was a winged system was now cited as a liability--due largely to the effective widespread anti-wing propoganda of the Ames' group. "Wings are for airplanes" they said.

A few months before the final denouement the DS-1 Project Office, in desperation, called on its old partner for help. I spent a day in Washington in March 1963 with Calvin Hargis, Milton Ames, and several others making the best case we could for saving the project. Much of the argument centered on the technology advances that would accrue. And much of it had a hollow ring. We all sensed that by now the case was probably hopeless.

Driving back to Newport News that evening on icy roads an oncoming car skidded into my lane, wiping out my small convertible,

but leaving me intact. I had suffered much in my travels for Dyna-Soar. Previously, an engine fire on take-off over San Francisco, a three-hour hold over Washington followed by a hair-raising late night landing in a blizzard, and now this!

Some valuable lessons were learned on Dyna-Soar. By the time of termination in December 1963 one could see that step-wise ascent through the glide or reentry corridors in the manner of the earlier manned research airplanes was not really essential to reentry vehicle technology advancement. For one thing the ranges became too long to be practical as the speeds approached orbital. The great successes of Project Mercury underscored other more appropriate development procedures, and at the same time provided an enormous increase in confidence level in ground facilities and in the viable technology achieved from intelligent combination of theory and partial-simulation data from a variety of facilities.

It might be argued that Dyna-Soar should have been terminated in the fall of 1961 when it was reoriented losing its research-airplane functions. Certainly, this would have resulted in major cost savings. (Troubled projects are seldom terminated as promptly as they should be from purely cost considerations; Ref. 25 gives an example). However, if that had been done many of the engineering developments of Dyna-Soar would have been stopped in such an early stage as to be of little value. It was the fitting of successful detailed engineering solutions into the general conceptual framework of a winged reentry vehicle that constituted Dyna-Soar's principal contribution. The NACA/NASA conceptual recommendations of 1958/59 were now tested, substantiated, and "fleshed out" in a real system.

Strong differences of opinion between Ames and Langley, which were often debated with some heat, reached their peak in the Dyna-Soar program and continued in milder form in the landable

lifting-body work described in the next section. It would be quite wrong for readers to assume, however, that there were any lasting personal animosities involved here. On the contrary, this competitive situation generally increased mutual respect, stimulated thinking, and enhanced the quality and pace of our R&D work.

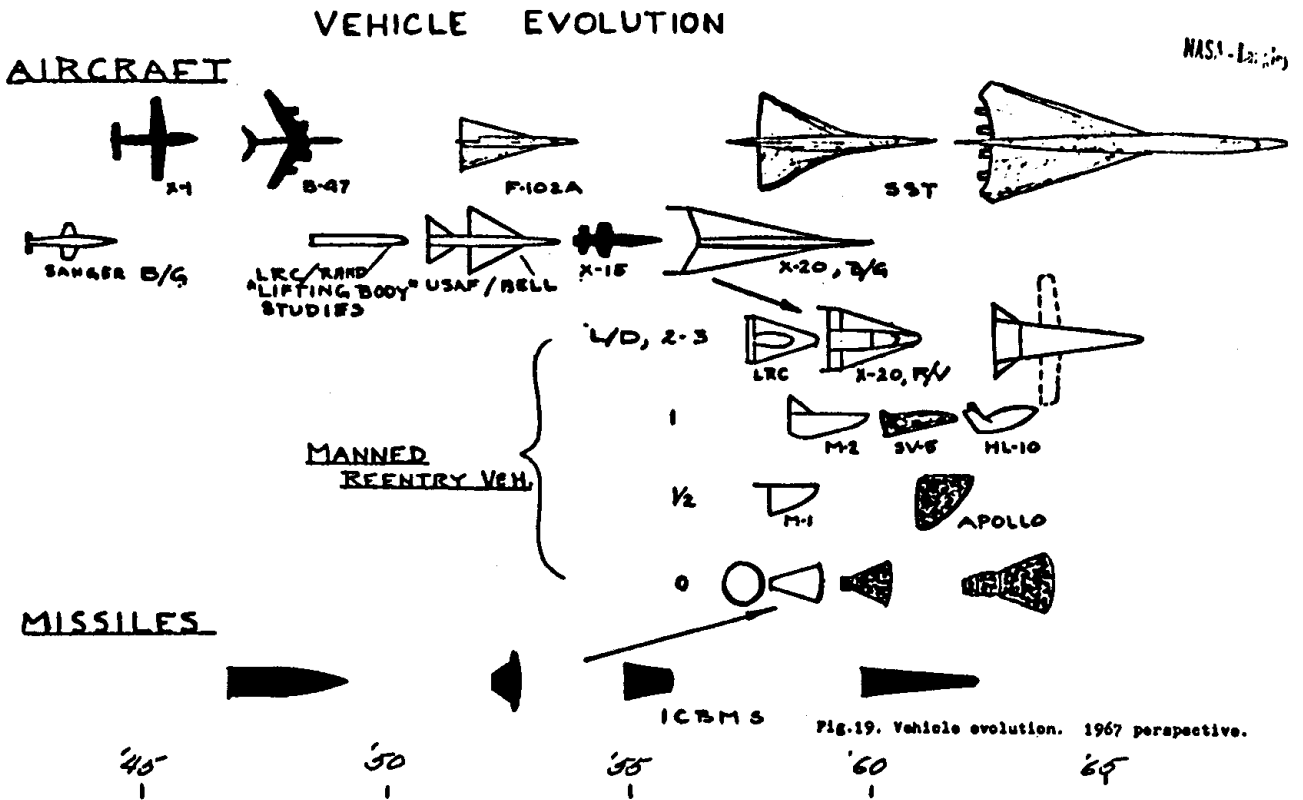
### The Lifting-Body Diversion on the Way to the Shuttle

The solid advances in all facets of winged reentry vehicle technology produced by Dyna-Soar seemed to have limited acceptance by the aerospace community of the early sixties. Instead, the demise of Dyna-Soar was interpreted by some as a failure or repudiation of winged reentry vehicles. There was an obvious psychological reaction. Like the proverbial rats, many aerospace vehicle specialists flocked over into the "lifting body" camp in 1963.

A month before the termination of DS the American Institute for Aeronautics and Astronautics had published my survey article on Entry Vehicles in which I have reviewed the cases for both winged and wingless vehicles (Ref. 26). I pointed to the relatively undeveloped state of technology of the lifting bodies, particularly in the areas of low-speed aerodynamics, handling qualities, heat protection, and related weights. Although I personally was still strongly biased towards the winged approach, it seemed obvious that we now must develop and assess the lifting bodies in serious detail in order to provide a firm basis for choice.

A 1963 chart which I used in several "reentry" talks is reproduced in Fig. 18. It suggests that the lifting-body concept is a hybrid deriving features from both aircraft and missile developments. Figure 19, with a 1967 perspective (Ref. 27), enlarges on these relationships with more detail, and with the

Figure 19



### VEHICLE EVOLUTION

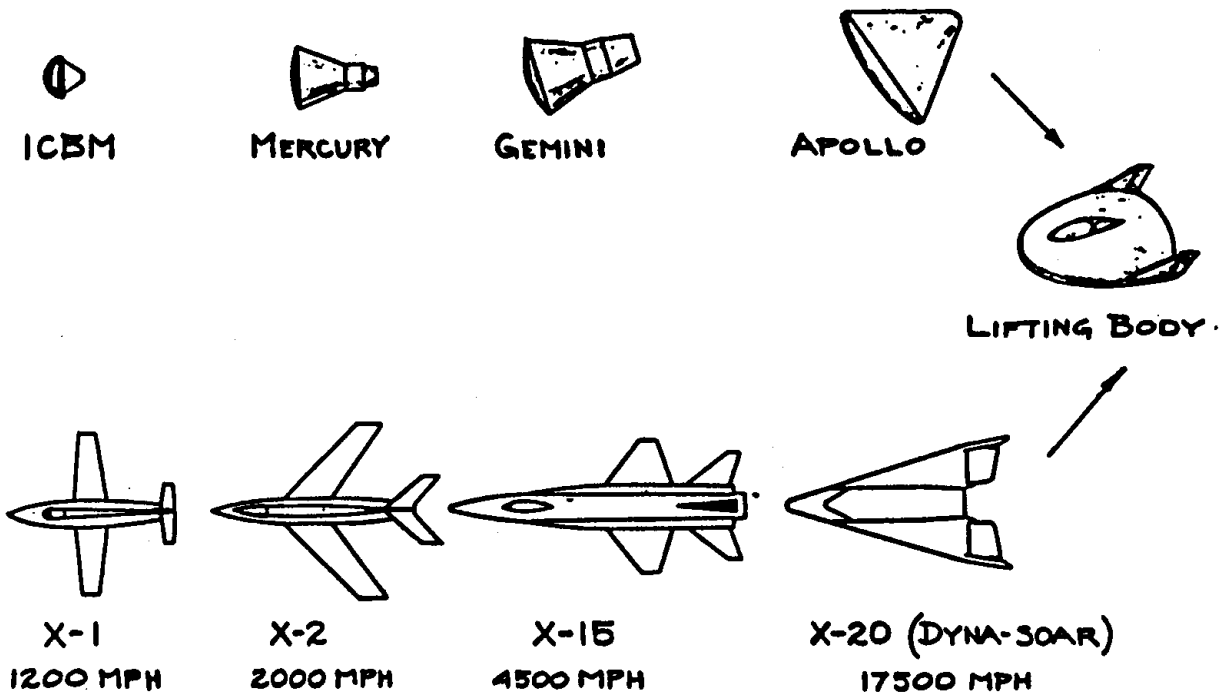


Fig.18. Pictorial vehicle evolution showing the contributions of both aircraft and missile technologies to manned reentry vehicle developments as seen in 1963.

addition of a time scale. (It may be noticed that a lifting body of extreme slenderness and hypersonic L/D of "3" is mentioned for completeness in Ref. 27 and Fig. 19 to indicate the upper possible limits. As shown on Fig. 19, such shapes would have to utilize switch-blade wings or other special devices for low-speed flight and landing).

E. S. Love, R. W. Rainey, B. Z. Henry, and others in Langley's hypersonic and configuration groups undertook the development of a flat-bottom, delta planform lifting body, starting in late '62. They sought a vehicle which would offer improvements over the Ames' M-2, the most highly-developed concept up to that time. In particular they were aiming for a large fraction of usable volume, natural self-trimming at high-lift altitudes, and improved low-speed handling characteristics. The Langley HL-10 (horizontal-lander, design 10) was the result some 18 months later after extensive analytical and wind tunnel work. A large scale piloted version started flights at Edwards in December of 1966. Two versions of the Ames' M-2, the M2-F1 and M2-F2, and the Air Force's SV-5P (X-24A) were also flown successfully in the Edwards program. Thus it was apparent beyond any further doubts that with careful design, sufficiently high aspect ratio, and with appropriate stability augmentation and artificial damping, lifting bodies in the hypersonic  $L/D \sim 1$  to 1.5 category could be made capable of piloted glide landings.

However, it was also clear from these programs that the low-speed L/D of the lifting bodies was always significantly less than that of winged vehicles similar planform and aspect ratio. This means that their descent rates are higher, and other factors being equal, their approach and landing characteristics are more critical with smaller margins for error than for the winged designs. A principal advertised advantage of the lifting body, increased volume per pound of weight, was found partly illusory, because



balance, packaging, and other requirements made a sizable part of the volume unusable, even in the HL-10. Furthermore the high volume cost something in added heat protection weight. That is, the net weight saving (if any) due to elimination of the wings was less than the weight of the shed wings.

In contrast to the weight "savings" hoped for by the early aerodynamicist promoters of wingless lifting bodies, it had been known since the time of "Phase Alpha" that the bodies were always heavier than winged vehicles of the same hypersonic L/D. In "Phase Alpha" an M-2b body of  $L/D \sim 1.3$  was found to weigh 9391 lbs at orbital injection, while a strictly comparable winged vehicle weighed only 8590 lbs. These careful estimates were made by qualified specialists from four aerospace firms. (Ref. 20).

#### The Winged Space Shuttle

With the successful flights of the small piloted lifting-body vehicles at Edwards, and with winged reentry systems having been dormant since 1963, it was naturally assumed by the lifting-body promoters that the Space Shuttle would employ one of their products. It came as a shock to them when the series of system studies starting in 1969 (Ref. 28) revealed that the Shuttle would have to be a winged configuration basically similar to Dyna-Soar but some 20 times heavier. The enormous cargo bay demanded for the anticipated payloads, 65 feet long and 15 feet in diameter, was practically impossible to fit into any reasonably proportioned lifting body. The higher hypersonic L/D of the winged design was needed for cross range. The wing also provides a higher reentry trajectory, shielding of the fuselage, better handling qualities, and extra margins for safety in approach and landing. The prospect of the "dead-stick" landing from space of this 180,000 lbs behemoth was far less fearsome and less risky with the extra aerodynamics of the wing.

Our basic 1958 postulate used in promoting the many advantages of winged reentry - that the modest weight increment of the wings would cease to be a critical consideration after booster technology advanced beyond its embryonic stage - was now amply confirmed.

In addition to enormous advances in booster technology, the Shuttle enjoys a thermal protection system far more effective and more durable than the metallic radiative structure of Dyna-Soar. In essence its lightweight ceramic blocks are the "unobtainium" that we could only dream of in the '50s and early '60s. In other sub-systems, however, the Dyna-Soar experience provided a technology base on which Shuttle designers could build. Virtually all of the reentry configurational and operational principles developed by NACA/NASA in the late '50s and applied in Dyna-Soar are followed in the Shuttle.

Tom Wolfe has discussed the winged Shuttle and its relationships to the previous research aircraft and space capsules from the point of view and emotional reactions of the Edwards airplane test pilots (Ref. 29). Their personal satisfactions on the realization of this flyable winged aircraft/spacecraft are shared by the researchers and engineers who visualized the possibilities and developed much of the underlying technology some 20 years before the first flight of the Shuttle.

## References

1. PARD proposal document, "Hypersonic Research" transmitted to Langley management June 5, 1953.
2. Brown, C. E., et al., A Study of the Problems Relating to High-Speed, High-Altitude Flight, Langley Memo, June 25, 1953.
3. Becker, J. V., "The X-15 Program in Retrospect," Raumfahrtforschung, March/April 1969.
4. Becker, J. V., "The X-15 Program." Part 1: "Origins and Research Background," Astronautics & Aeronautics, Feb. 1964.
5. "NACA Views Concerning a New Research Airplane." NACA, Washington, Aug. 23, 1954.
6. Eggers, A. J.; Allen, H. J.; and Neice, S.; A Comparative Analysis of the Performance of Long Range Hypervelocity Vehicles, NACA RMA54L10, 1954.
7. Hypersonic Research Airplane Study. Memo for Assoc. Director, Jan. 17, 1957, J. V. Becker.
8. Korycinski, P. F., Note to John Bailey dated Jan. 25, 1957, (Copy attached. The presentation charts referred to are Fig. 1, taken from Ref. 7). See appendix, where this note is reprinted in full.
9. Preliminary Investigation of a New Research Airplane for Exploring the Problems of Efficient Hypersonic Flight. By the Staff of the Ames Aero. Lab., Jan. 18, 1957.
10. First Meeting of Steering Committee on New Research Airplanes Feb. 14, 15, 1957. Memo RAPL to NACA Hq., Mch. 5, 1957.
11. Supplemental Report for Ref. 9 above. By the Staff of the Ames Aero. Lab., May 17, 1957.
12. "NACA Views on a Hypersonic Research Airplane." NACA, Washington, July 23, 1957; Revised version, Sept. 8, 1957.
13. Korycinski, P. F., Report on Interlaboratory Round III discussions. Memo for RAPL dated Nov. 1, 1957.
14. Material presented at Round III Meeting. Folder in J. V. Becker files, 1957.
15. Syvertson, C. L., A Short History of Lifting Bodies. NACA document evidently prepared at E. O. Pearson's request in 1967. (See JVB copy).

16. NACA Let. Crowley to Reid 11/18/57.
17. Becker, J. V., and Korycinski, P. F., The Surface Coolant Requirements of Hypersonic Gliders. NASA Memo. Report 1-29-59L, April 1959.
18. Cooper, P. A., and Holloway, P. F., "The Shuttle Tile Story," Astronautics and Aeronautics. Vol. 19, No. 1, Jan. 1981.
19. Becker, J. V., "Reentry from Space," Scientific American, Jan. 1960.
20. USAF/NASA Joint Conference on Lifting, Manned, Hypervelocity and Reentry Vehicles. Compilation of Papers Presented. Langley Research Center. April 1960.
21. NACA Conference on High Speed Aerodynamics. Compilation of Papers Presented on March 18, 19, and 20, 1958. Paper No. 4, p. 45-58, J. V. Becker.
22. Dyna-Soar briefing for Webb, Dryden, and Seamans on Jan. 4, 1962. Langley Res. Center Files.
23. Eggers, A. J., Some Considerations of Aircraft Configurations for Long-Range Hypersonic Flight. Paper presented at Symposium on Hypersonic Flow, U. of Bristol, England Ap. 6, 1959.
24. Report of the Aero and Space Vehicles Panel of the SAB on Dyna-Soar, Jan. 1960, USAF HQ Files.
25. Becker, J. V., A Hindsight Study of the NASA Hypersonic Research Engine Project. Unpublished study for NASA/OAST Propulsion Division, 1976.
26. Becker, J. V., "Entry Vehicles," Astronautics and Aerospace Engineering, Nov. 1963, AIAA.
27. Becker, J. V., Notes on the Evolution of "Lifting-Body" Manned Reentry Vehicles. Review prepared for NASA/OAST Space Vehicle Office, Dec. 1967.
28. Hallion, Richard P., "The Antecedents of the Space Shuttle." XXXth Congress, IAF, Sept. 21, 1979.
29. Wolfe, Tom, "Columbia's Landing Closes a Circle," National Geographic, Vol. 160, No. 4, Oct. 1981.

## APPENDIX

P. F. Korycinski's Note to John Bailey, January 25, 1957

This note from P. F. Korycinski to John Bailey refers to our first formal presentation of our HYWARDS study (Ref. 7) on Jan. 11, 1957 in which the use of low L/D "to avoid long-duration heating" was first discussed. See also Fig. 1.

EXACT COPY

John,

January 25, 1957

Your point about L/D reducing to 1 as satellite velocity is approached is, of course, correct. You may recall in Becker's recent presentation at the Administration Building his discussion of the advantages of flight at high angles of attack for global range. The angle of attack was  $20^\circ$  which gave an L/D of 2.3. His argument ran something like this: For global range, you need a velocity of 25,300 ft/sec for flight at L/D = 4.6. By increasing the speed about 3 percent, you can fly at an L/D of 2.3 (or even less) and avoid long duration heating. At satellite velocity L/D as such has no significance.

But, on the other hand, where we can't obtain satellite velocities, range is very definitely a function of L/D. In our case, where  $V = 14,800$  ft/sec and L/D = 4.6, we expect to have a range of about 3200 miles. In the Ames case where they expect to fly at  $V = 11,000$  ft/sec and an L/D = 6, they expect a range of 2000 miles. (Incidentally, Love calculated the L/D for the Ames configurations on the same basis he used to calculate our configuration and got an L/D = 4.64 - almost identical L/D's for both configurations. Their estimated range would be correspondingly less, too).

The main point of this note is that as long as we are limited in velocity at burnout, range is dependent upon L/D - the higher the more range. (Attached is our own L/D - range plot).

Sometime ago Becker looked into the question of boost-glide and boost-sustain glide. On this point, my memory is not too clear, but I do believe that he concluded that boost glide gives the more efficient aerodynamic performance, range included. There is a considerable penalty involved in not using the second stage propellants to achieve higher velocity and altitude. So you end up flying a heavier vehicle (the weight of which decreases slowly as the fuel is used up) in a denser atmosphere and your range ends up by being less than that for the boost glide vehicle. [The vehicle is also hot and the idea of carrying around substantial quantities of propellants in a hot structure any longer than necessary is not appealing.]\*

Boost-sustain-glide operation, however, is a consideration when we are not concerned with maximum range. It is likely that it would be desirable to operate the vehicle in this manner.

Pete Korycinski

PFK:mcc

---

\*Bracketed text added later by hand.

**CASE IV**

**ASSET: PIONEER OF LIFTING REENTRY**

**by**

**Richard P. Hallion**

## EDITOR'S INTRODUCTION

Termination of Dyna-Soar seriously impeded the advance towards increasing understanding of hypersonic flight and the generation of a technology base permitting the exploitation of the hypersonic flight regime. Nevertheless, a considerable body of work continued, though not, of course, involving expenditures of "big ticket" funding.

One of the most productive research efforts in hypersonic flight was that of the ASSET project--a minimal cost, minimal size effort involving the firing of heavily instrumented hypersonic glider models down the Eastern Test Range from Cape Canaveral, Florida, using Thor and Thor-Delta boosters. ASSET gave investigators their first experience with hypersonic reentry at near-orbital speeds from a space environment, and it paved the way for the PRIME project which followed.

This case study examines an "on the cheap" hypersonic research effort and the impact it had upon subsequent hypersonic technology advancement. As is quickly evident, ASSET had an importance and impact all out of proportion to the investment it required. Further, it stands as a classic example of how appropriate research using subscale free-flight test models can beneficially impact flight technology. As such, ASSET furnishes a useful perspective for today's researchers as they pursue development of the proposed Boost Glide Vehicle (BGV) demonstrator currently gestating at Aeronautical Systems Division.



## CHAPTER I

### ASSET: ORIGINS, CONCEPT, AND DESIGN

The demise of Dyna-Soar at the hand of Secretary of Defense McNamara did not relegate the study of lifting reentry from space in the United States to the merely theoretical. Instead, it furnished an important stimulus to a small but extremely significant project run by the Research and Technology Division (RTD) of the Air Flight Dynamics Laboratory (FDL) at Wright-Patterson Air Force Base, Ohio: ASSET--for Aerothermodynamic/elastic Structural Systems Environmental Tests.<sup>1</sup>

ASSET involved lofting small hypersonic gliders down the Eastern Test Range from Cape Canaveral (subsequently renamed Cape Kennedy briefly before being restored to its original name) on the top of modified Douglas Thor and Thor-Delta boosters. Its origins dated to 1959, and as with the early X-series aircraft, it was intended to substitute for the lack of adequate ground test facilities and as a stimulus to evaluate, refine, and develop such facilities. The ASSET gliders were small flat-bottomed vehicles having a 70 degree delta wing possessing a total wing area of 14 square feet joined to a simple body shape consisting of a sharply tapered cone combined with a skewed cylinder-like body. ASSET's planners intended to:<sup>2</sup>

. . . assess, through free-flight tests, the applicability and accuracy of theories, analytical prediction methods, and experimental techniques available for the solution of reentry problems in structures, aerothermodynamics and aerothermoelastics.

ASSET had evolved in straight-forward fashion. In August 1959, what eventually emerged as ASSET began as an in-house FDL study under Projects 1366 (Aerodynamics and Flight Mechanics) and 1368 (Structural Configuration Concepts for Aerospace Vehicles), both of which were part of the on-going 750A (Mechanics of Flight) Applied Research Program. Early study results indicated that the advent of new high-temperature materials and development of the guidance package for the Scout booster could permit the development of large-scale hypersonic flight test models representative of planned reentry shapes. These models could be lofted by modified Air Force Blue Scout boosters--the Blue Scout being a derivative of the NASA Scout booster then on the verge of entering America's launch vehicle inventory. FDL's first attempts to initiate projects in the area of reentry aerodynamics and aerothermodynamics failed because the service simply could not spare any boosters for use in applied research programs of the sort that FDL was then contemplating. A follow-on study contract, launched in April 1960, was successful, however. This follow-on study had combined the earlier interest in aerodynamics and aerothermodynamics with aerothermoelasticity and vibration, and included mention of virtually all of these interests in long and complex title, fortunately shortened to the acronym ASSET.<sup>3</sup>

In their initial formulations, ASSET's planners had settled on a simple blended wing-body shape that has a pronounced keel on the ventral surface. Recognizing that the keel design would induce a dihedral effect problem to the design, as well as serve as a focal point for heating, engineer Alfred Draper instead argued persuasively for a configuration similar to the so-called WLB-1 design sponsored by the FDL. The ultimate configuration chosen for ASSET bore a rough similarity to that of the planned Dyna-Soar then undergoing development. ASSET (Figure 1) had a rounded nose cap, and rounded wing leading edges, coupled with a tilted undersurface ramp for hypersonic trim and a flat-bottom delta wing. The dorsal surfaces consisted of a cone coupled with

Length	68.82 Inches
Span	54.88 Inches
Height	32.79 Inches
Wing Sweep	70 Degrees (True)
Wing Area	14 Square Feet
Nose Tip Radius	3 Inches
Leading Edge Radius	2 Inches
Average Weight	
Aerothermodynamic	
Structural Vehicle	1130 Pounds
Aerothermodynamic	
Elastic Vehicle	1225 Pounds

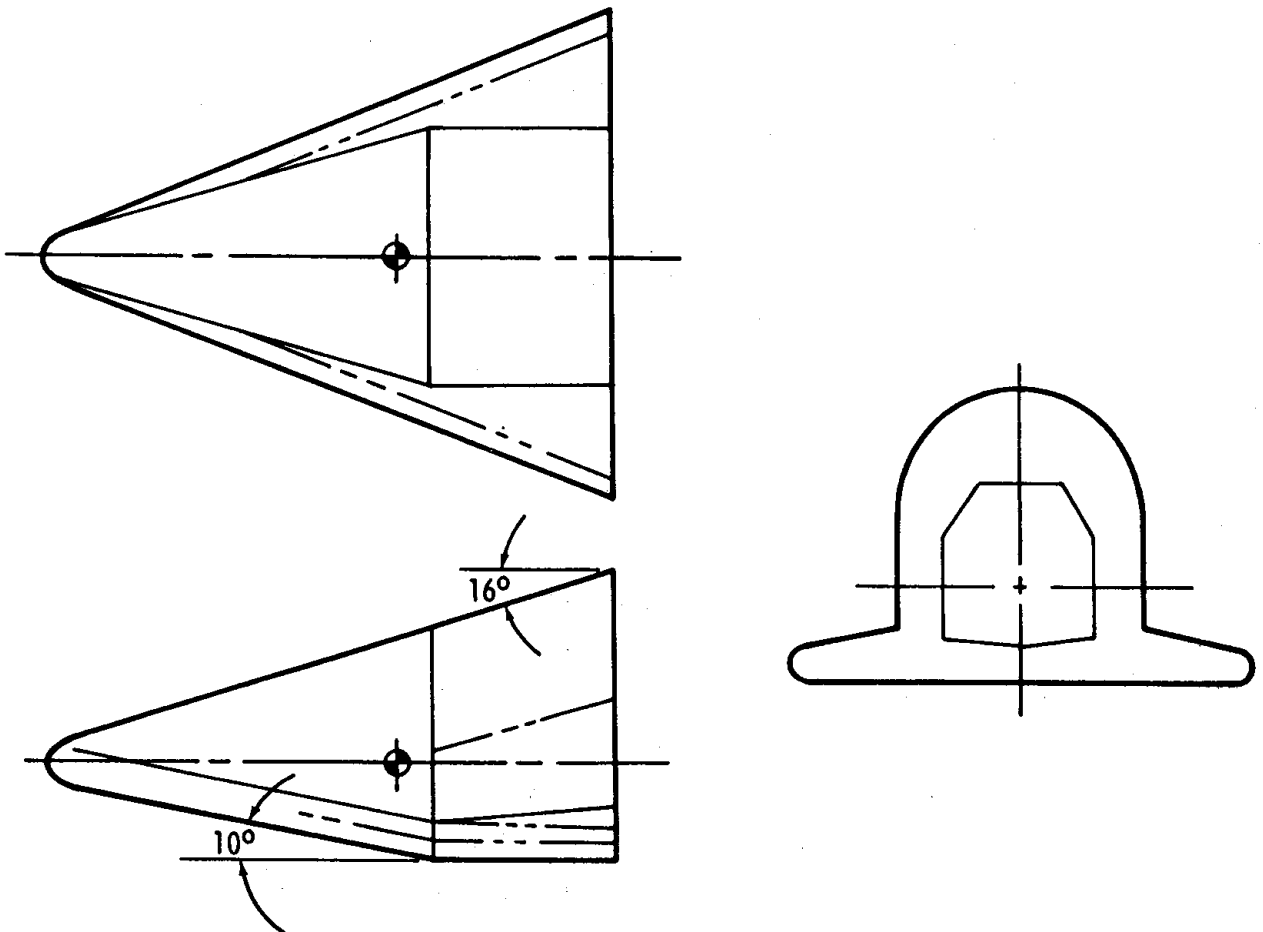


Figure 1 ASSET Vehicle Configuration

a modified cylinder. The similarity to Dyna-Soar enabled the ASSET vehicle to take advantage of a large body of wind tunnel studies completed or underway relating to the generally similar Dyna-Soar configuration.<sup>4</sup>

FDL built its initial plans around seven payload vehicles, though this eventually changed to six, involving development of two similar configurations that differed greatly in capabilities and purpose. Dr. C. D. Perkins, the Assistant Secretary of the Air Force for Research and Development, granted development approval for ASSET--the reformulated program undertaken after the earlier 750A-1366 and -1368 effort--on January 31, 1961. Subsequently, it became a project of its own, as Project 1466 within the 750A Applied Research Program. (Eventually, in July 1962, ASSET transferred from the 750A Program to an AFSC-directed Advanced Technology Program, as Program Element 63409874 within Program 698CN).<sup>5</sup> In April 1961, the Air Force awarded a cost-plus-fixed-fee contract, AF 33(616)-8106, the first of three major ASSET-related contracts, to the McDonnell Aircraft Corporation of St. Louis, Missouri, for development of the small payload vehicles. In separate actions, the Air Force awarded contract AF 33(657)-9391 (a fixed-price contract) to the Minneapolis-Honeywell Corporation on June 4, 1962 for modification and fabrication of a guidance system (based on the proven Scout) for use with ASSET and its booster, as well as a contract in November to Douglas Aircraft Corporation for the booster.<sup>6</sup>

The booster contract had an interesting genesis that requires some explanation. By late 1961, as ASSET advanced rapidly down the road of development, project planners recognized that as good as the Scout system was, it could not compete with other contemporary boosters such as the more powerful Douglas Thor and Thor-Delta vehicles; further, its length posed potentially fatal bending-moment loads problems. Fortunately for ASSET, the United States was returning Thor intermediate range ballistic

missiles (IRBM) from Great Britain, where they had stood nuclear watch, crewed by personnel of the Royal Air Force. The return of the UK Thors offered ASSET a launch system having significant advantages over the Scout including proven reliability, better performance, greater growth potential, improved booster/payload compatibility, comparable costs, and more simplified procurement. ASSET, by this time, consisted of two project efforts (as will be discussed subsequently in greater detail): the Aerothermodynamic Structural Vehicles (ASV) and the Aerothermoelastic Vehicles (AEV); McDonnell would build four of the former and two of the latter. The latter would make use of the modified standard Thor launch vehicles, the Douglas DSV-2F. The former would use a two-stage booster consisting of a DSV-2F Thor first stage and an Aerojet AJ10-118 (the Delta) second stage, this coupled unit being known as the DSV-2G, though one of the four ASV vehicles would fly on a standard DSV-2F rather than the two-stage DSV-2G. In June 1962, DDR&E approved changing from the planned Scout booster to the Thor; the Air Force Space Systems Division awarded Douglas a contract for launch vehicle system modification and engineering in November 1962 though, in any case, the first returning Thors available for ASSET were not officially assigned until January 15, 1963. Originally, the ASSET project team had hoped that the first test vehicle would fly on Scout in January 1963. The opportunity to obtain the higher-performance Thor and Thor-Delta launchers offset somewhat the disappointment at not being able to fly as soon as had been planned (ASSET did not make its first flight until September 18, 1963, nine months later than planned for Scout). Nevertheless, the availability of modified Thors became the single most significant factor influencing the ASSET launch schedule. Contractual difficulties between NASA and the Air Force briefly delayed the Delta second stage, scheduled for use on the second, third, and sixth ASSET launches, with a resulting impact on the schedule for the second and subsequent flights. Overall, however, the Thor family's higher performance

warranted replacing Scout, and subsequently justified the decision of those who sought to use this versatile system in place of the less powerful Scout launch vehicle.<sup>7</sup>

Eventually the ASSET project cost American taxpayers \$21,236,000, a reasonable sum considering the amount and value of the research information returned by the five ASSET vehicles successfully flown (a sixth--the second actually launched--self-destructed as a result of booster failure). The Thor boosters ran another \$19,861,000, bringing all ASSET-related costs to \$41,097,000. An actual breakdown of ASSET vehicle costs indicates the "on the cheap" nature of this remarkable and highly successful program:<sup>8</sup>

Airframe	\$ 3,961,000
Guidance and Control	1,298,000
Reaction Control System	356,000
Telemetry, Tracking, & Comm.	1,291,000
Electrical Power & Distribution	290,000
Environmental Control	33,000
Recovery System	904,000
Aerospace Ground Equipment	177,000
Program Management	1,229,000
System Engineering	3,653,000
Vehicle Assembly	2,096,000
Interstage	103,000
Ground Test	1,972,000
Flight Test Operations	1,185,000
Self-Destruct System	423,000
G & A Expense	1,359,000
Fixed Fee	906,000

Total: \$21,236,000

It is interesting to note that flight test and ground test together totalled \$3,157,000, approximately fifteen percent of the

total ASSET costs. Ground test costs alone constituted approximately nine percent of the total--a small sum, and yet one of the major benefits of the entire ASSET effort was its giving engineers an actual example of hypersonic hardware forcing comprehensive testing (particularly with regard to high-temperature structures) and development of sophisticated (for their time) test apparatus and methodologies. Finally, though ASSET flight testing would clearly benefit the X-20 then under development, it did so on its own, without using any X-20-dedicated moneys.

ASSET management involved primarily the Flight Dynamics Laboratory, but other governmental and private organizations had a hand in it as well. Overall, the Research and Technology Division of the FDL had responsibility for general project management, technical support, and coordination. RTD furnished the ASSET research vehicles, associated equipment, and related services. Air Force Space Systems Division's Standard Launch Vehicle II Directorate provided the Thor boosters for ASSET as well as launch vehicle operations services at the Atlantic Missile Range (Cape Canaveral) in support of ASSET operations. SSD's 6555th Aerospace Test Wing at Patrick Air Force Base, Florida, served largely as the "on-site" management for ASSET operations as well as providing a great deal of coordination between the FDL, AMR, and Air Force Missile Test Center (AFMTC) at Patrick. For its part, the AFMTC furnished launch and downrange facilities and support services for ASSET operations.<sup>9</sup>

As specified in the ASSET project plan, the detailed responsibilities and duties of these aforementioned organizations were:<sup>10</sup>

RTD

1. provide engineering, design, and fabrication of the ASSET research vehicle and interstage structure.

2. provide all integrated flight planning to include, but not be limited to, the AMR documentation for the complete program.
3. provide ASSET research vehicle technical field representation as well as equipment support.
4. provide ASSET research vehicle spares in sufficient quantity to preclude foreseeable pre-launch delays.
5. provide and maintain ASSET-launch facility and ASSET-launch vehicle interface drawings, which will be approved mutually by RTD and SSD.
6. provide electrical receptacles at the ASSET-launch facility and ASSET-launch vehicle interface to the launch vehicle contractor.
7. conduct coordination meetings as deemed necessary to preclude delays in the program.
8. provide ASSET boost-phase characteristics to the launch vehicle contractor.
9. provide ASSET interstage to the launch vehicle contractor for verification of mechanical compatibility and electrical continuity.
10. provide, prior to arrival of the ASSET vehicles and Thor launch systems at AMR and in mutual agreement with all organizations concerned, checkout procedures, count-down procedures, coordination and management channels, ASSET-Thor integration, and ASSET-Thor combined operations.



11. provide launch vehicle requirements to SSD.
12. provide to AMR, in accordance with schedules to be established, the complete ASSET research vehicle and interstage, fully instrumented and checked out, both functionally and environmentally.
13. analyze all data, examine recovered vehicles, and prepare reports including results of such analysis.

#### SSD

1. provide launch vehicles in accordance with schedules to be established.
2. provide FDL with the launch vehicle electrical and mechanical interface for the ASSET vehicles.
3. provide design modifications necessary to the launch vehicle and launch facilities to meet the requirements of the ASSET program.
4. provide launch vehicle system technical field representation and support.
5. provide FDL all trajectories, loads, dispersion computations, heating, vibration and separation characteristics for the launch vehicle, and supporting data for the above.
6. provide a retrorocket system to separate the launch vehicle from the ASSET vehicle.
7. provide FDL a master gauge for control of the interface mechanical attachment.

8. provide FDL with a description of the launch facility.
9. provide FDL with the combined countdown procedures.
10. provide launch vehicle system aspects of flight planning and coordination.
11. provide for the launch of the Thor launch vehicle systems supporting the ASSET project.

6555th ATW

1. be responsible to FDL as ASSET project representative at AFMTC.
2. be responsible for accomplishing launch vehicle test control.
3. provide launch vehicle system support that is required for the ASSET project at AFMTC.
4. provide all ASSET project requirements and documentation to AFMTC for all launch support.
5. act as program director and launch user for Project ASSET at AMR.
6. coordinate all appropriate ASSET documentation with FDL and SSD.
7. provide AFMTC with the booster requirements, pad safety requirements, master countdown, test schedule request for the Thor launch vehicle systems, and all

other required documentation that support the ASSET project.

#### AFMTC

furnish launch sites, downrange tracking (X-band and AN/FPS-16), telemetry receiving equipment (X-band and VHF), recovery equipment, data reduction facilities, and all personnel to operate the listed equipment and facilities.

The ASSET Project Office functioned within the Flight Dynamics Laboratory at Wright-Patterson Air Force Base. From the outset, the size of the office was minimal; project manager C. J. Cosenza (a young GS-12) supervised a staff of only four engineers and one secretary to carry out the management workload, with approximately seventeen other FDL engineers supporting the lab's ASSET effort. The office experienced staff turnover, as other programs and projects developed needs of their own that could be filled (albeit reluctantly) by reaching within the small ASSET office. For example, in the three years from FY-61 to FY-64, only two of the original five authorized technical personnel assigned to the ASSET Project Office remained with the office. The other three positions had been filled, off and on, by seven other people. (Fortunately this disruptive trend failed to wreak the havoc one would normally expect). Much of ASSET's success stemmed from Cosenza's careful and shrewd management of the project. His counterpart in McDonnell, program manager C. D. "Cliff" Marks, managed a larger staff which, at its peak in 1963, consisted of 269 individuals involved with tooling, experimental construction, engineering, and quality control. The effective working relationship of Cosenza and Marks compared in many ways to the equally successful and mutually beneficial relationship between Northrop's Ralph Hakes and NASA's John McTigue during

the M2-F2/F3 and HL-10 lifting body development effort. One subsequent commentator, S. A. LaFavor (Director of Advanced Development and Analysis for the McDonnell Douglas Corporation), wrote that "The success of the ASSET program was in no small measure achieved because of the efforts of . . . Joe Cosenza . . . and Cliff Marks."<sup>11</sup> Figure 2 shows the lines of communication involving all players in the ASSET program.<sup>12</sup>

### Research Objectives and the ASSET Vehicles

From its inception, ASSET had three distinct technical goals:<sup>13</sup>

1. To evaluate structural configuration concepts and to provide structural design information in the hypervelocity flight environments that could be used for military aerospace vehicle design.
2. To provide panel flutter data and oscillatory pressure data on a trailing edge flap in a hypersonic environment for coordination with theory.
3. To investigate aerodynamic and aerothermodynamic phenomena and evaluate performance parameters for military glide reentry systems in low density flow.

The first of these constituted a logical outgrowth from earlier experimental programs; the Bell X-2 (first flown as a powered aircraft in 1955) had been the first rocket-propelled research vehicle that had to be designed with thermodynamic considerations in mind, and it had a flight structure fabricated from stainless steel and a nickel alloy. The X-15, with an Inconel alloy structure, had gone considerably beyond, a necessity forced by its Mach 6 mission goals. But the requirements of a genuine return from earth orbit or a suborbital flight would require reentry

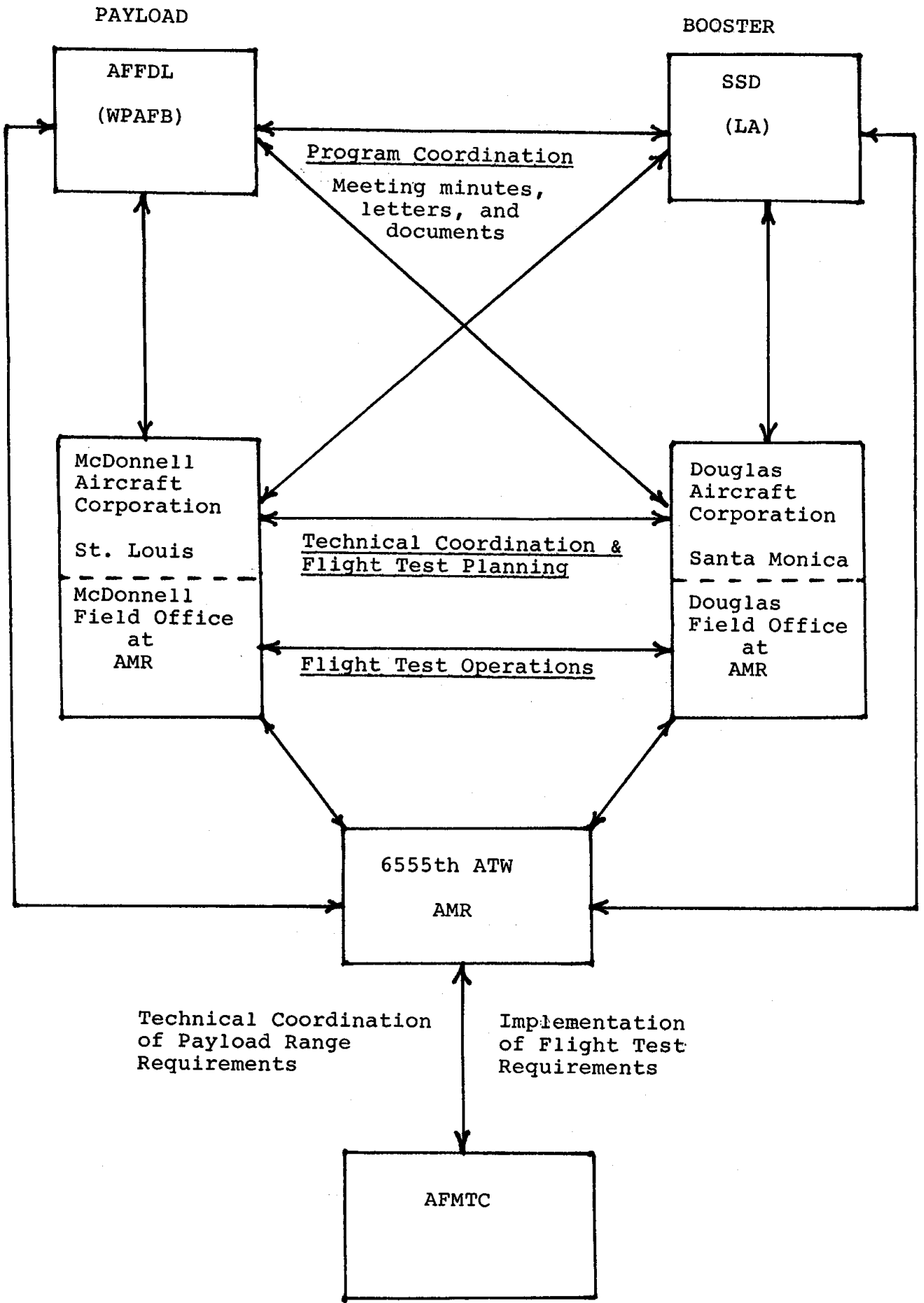


Figure 2

vehicles to be able to cope with prolonged heating measured not in seconds of duration, but in minutes, and characterized by genuine heat-soaking rather than a quick thermal pulse.

The second point reflected an old problem in high-speed aerospace vehicle design: flutter. Combinations of oscillatory aerodynamic, elastic, and inertial forces can generate sustained oscillations of structural members such as wings, control surfaces, fins, pylons, and surface panels. The majority of supersonic aircraft produced since 1947 have exhibited some degree of this "flutter" tendency; for example, panel flutter was a cause of concern on the McDonnell F-101 Voodoo tactical fighter program, and the subsequent Northrop T-38 Talon trainer effort as well. During testing of the X-15, panels on the long chine-like housings flanking the circular cross-section fuselage exhibited flutter at speeds above Mach 2.4, forcing the hasty retrofitting of longitudinal stiffeners to cure the problem. At hypersonic speeds, high temperatures greatly reduce structural stiffness, increasing the vulnerability of aerospace vehicles to possibly destructive flutter tendencies. During X-20 development, approximately eighty percent of the X-20's external panels were designed specifically to overcome anticipated flutter problems, following studies of an earlier X-20 configuration that appeared to be highly susceptible to flutter. Flutter posed a thorny design problem, for rocket propulsion systems technology in the early 1960s dictated that any reentry vehicle be as light as possible. Yet stiffness requirements for overcoming flutter tendencies demanded a heavier structure--a potentially vicious circle. Little doubt existed that flutter would constitute a serious problem for hypersonic reentry vehicles, because the basic physical circumstances of high supersonic and hypersonic flight dictated it so. As a lifting reentry vehicle descended at a high angle of attack through the atmosphere, compression effects through the detached bow shock wave enveloping the vehicle generated increased dynamic pressure ("q") coupled with a reduction in local Mach number over the

undersurface of the vehicle, generating environmental conditions conducive to triggering panel flutter.<sup>14</sup>

From an aerodynamics standpoint, one of the most valuable contributions ASSET could make would be in the improving of understanding of pressure variations over an oscillating control surface. This understanding, when correlated with theory, could enable future spacecraft designers to better predict and anticipate unsteady aerodynamic loads. A suitably instrumented trailing edge flap located on the aft underside of the flat-bottomed little delta could furnish just such information, and was quickly accepted for inclusion on ASSET as an experiment for the Aerothermoelastic Vehicles (AEV) to be flown.<sup>15</sup>

The third goal related to the minimal amount of free-flight research that had been undertaken prior to ASSET and the paucity of ground-based instrumentation and test facilities serving as predictive tools for hypersonic vehicle development. Most of these tests had involved evaluations of specific reentry nosecone shapes using research vehicles such as the Lockheed X-17, driven down into the atmosphere at high speed into the dense lower altitudes. These conditions were not at all similar to those encountered by a returning lifting reentry glide vehicle, going from the vacuum of space into the tenuous upper atmosphere, gradually heating, and then heat-soaking the structure at hypersonic speeds for twenty or so minutes before dropping to supersonic velocities and cooler temperatures as it descended into the lower atmosphere. In contrast, as the ASSET project plan stated, ASSET<sup>16</sup>

. . . is intended to provide knowledge in the state-of-the-art of true simulation to the point where hypersonic glide and lifting reentry vehicles can be designed and analyzed with accuracy and assurance. Free flight test of a glide reentry vehicle will be conducted to obtain data in the areas of aerothermodynamics, structures, and aerothermoelasticity. Emphasis will be placed on investigating those areas where advanced theory--while based

on best available, but not thoroughly verified, experimental assumptions--predicts that current approaches and methods of analyses could be in error.

Thus, like many flight research vehicles before it, ASSET would correlate flight test with ground test data, verify theories and prediction techniques, and evaluate structural concepts and materials. If successful, it would generate manufacturing technology, advance overall system technology, and resolve many of the operational problems anticipated in hypersonic flight.<sup>17</sup> The ASSET Project Office determined to develop ASSET using an approach based on simplicity, reliance on a predictable and tested configuration, developing a minimum-size vehicle, adopting a minimal cost approach, seeking timeliness in procurement and development, seeking applicability to other systems contemplated, and, finally, following an "off-the-shelf" design and procurement approach wherever possible.<sup>18</sup>

As previously mentioned, ASSET had a 70 degree delta wing having a 10 degree upward tilt of its undersurface (termed the ramp), and a flat-bottom (termed the flap). The dorsal body consisted of a cone joined to a skewed and modified cylinder shape, the breakline between the cone and cylinder coinciding with the breakline on the ventral surface of the vehicle separating the ramp from the bottom flap area. Two different ASSET spacecraft--the ASSET Aerothermodynamic Structural Vehicles (ASV) and the ASSET Aerothermoelastic Vehicles (AEV)--used this basic design approach; although superficially externally similar, and sharing common subsystems, the craft differed completely in mission, and had differing research capabilities that were reflected in totally different flight profiles. The ASV's had as their mission to determine temperature, heat flux, pressure distribution, and evaluate materials and structural concepts under conditions of hypersonic gliding reentry. Researchers would launch four of the



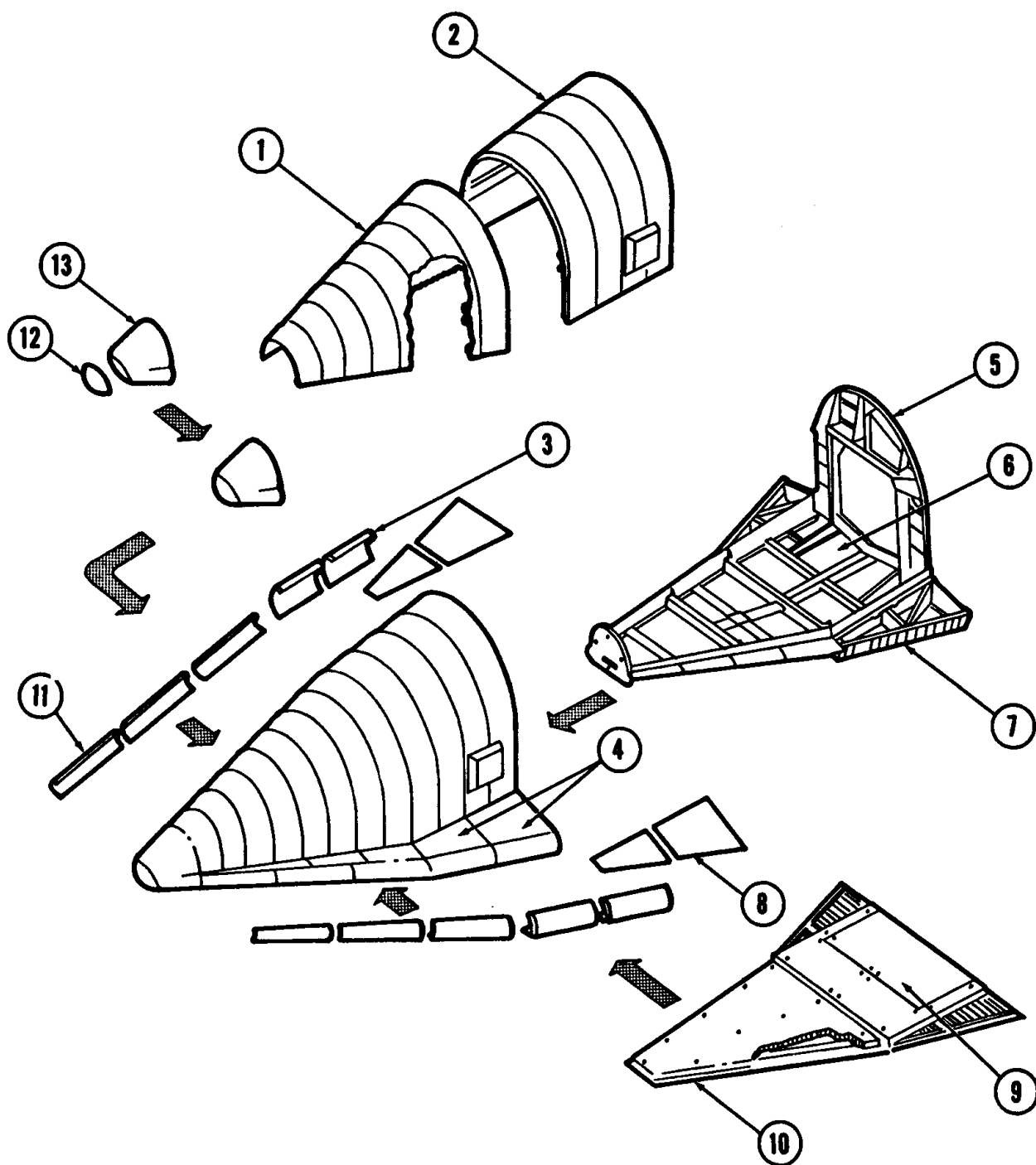
ASV's, one on a single-stage DSV-2F Thor, and the rest on multi-stage DSV-2G Thor-Deltas. Generally, planners expected the ASV's to boost to altitudes ranging from 190,000 to 225,000 feet, and velocities from 16,000 to 19,500 feet per second, giving them a range varying from approximately 1,000 to 2,300 nautical miles. The AEV's, on the other hand, would boost to 168,000 and 187,000 feet at a 13,000 foot per second velocity, attaining ranges of 620 and 830 n. m. (These figures underwent revision subsequently, and the final flight values differed somewhat as well). Only two AEV's would be launched, both by DSV-2F boosters. Both the ASV and the AEV shared the ASSET design's common dimensions, as listed on Figure 1. But they differed appreciably in weight due to differing mission and experiments requirements; the ASV weighed approximately 1130 lbs, and the AEV 1225 lbs.<sup>19</sup>

ASSET demanded insightful design, particularly since necessity forced utilization of new materials for its then-exotic structure. Figure 3 gives a materials and structural breakdown of the basic ASV, coupled with the expected thermal environment. Figure 4 shows the anticipated dorsal and ventral heating environment in relation to ASSET body stations.<sup>20</sup> Figure 5 shows the location of the flutter experiment panel and the aerodynamic control surface experiment flown on the AEV vehicles; these two experiments constituted the principle visible difference between the ASV and AEV ASSET spacecraft.<sup>21</sup>

ASSET vehicles contained six significant subsystems: guidance and control, data sensing, commutation and telemetry, tracking, recovery, and range safety self destruct. As stated earlier, the Minneapolis-Honeywell Corporation had responsibility for the modification and fabrication of the ASSET guidance package, based upon the proven Scout. The ASSET guidance package guided and controlled the flight of the little hypersonic glider, provided attitude data for transmission to ground stations, and furnished



Figure 3



ASSET ASV Materials Breakdown

Figure 3 (concluded)

- |   |   |
|---|---|
| <p>① Forward upper body<br/>Columbium 2500°F<br/>0.019 skin<br/>0.019 corrugation<br/>F-182 Min-K insulation</p> <p>② Aft upper body<br/>L-605 cobalt alloy 2000°F<br/>0.010 skin 0.012 corrugation<br/>F-182 Min-K insulation<br/>Black ceramic finish</p> <p>③ Aft leading edges<br/>Columbium (1% Zr) 2700°F<br/>Machined from 0.25 inch plate<br/>with integral ribs</p> <p>④ Teflon 0.375 thick</p> <p>⑤ Aft bulkhead<br/>Titanium 1000°F<br/>0.025 web 0.050 cap<br/>A-100 Refrasil insulation<br/>Black ceramic finish</p> <p>⑥ Floor assembly<br/>Titanium 1000°F (local)<br/>0.080 aft 0.125 fwd<br/>F-182 Min-K insulation</p> <p>⑦ Aft beam and truss<br/>Columbium 2500°F<br/>A-100 Refrasil insulation</p> | <p>⑧ Upper wing panels<br/>L-605 cobalt alloy (bruzed)<br/>1800°F<br/>0.010 skin<br/>0.010 corrugation</p> <p>⑨ Aft flap heat shields<br/>Columbium 2500°F<br/>0.016 skin 0.011 corrugation<br/>F-182 Min-K insulation<br/>Fiberfrax insulation<br/>A-100 Refrasil insulation</p> <p>⑩ Forward ramp heat shields<br/>Molybdenum 3000°F<br/>0.029 skin 0.019 corrugation<br/>F-182 Min-K insulation<br/>Fiberfrax insulation<br/>A-100 Refrasil insulation</p> <p>⑪ Forward leading edges<br/>Graphite 3000°F<br/>Machined from rectangular bars<br/>Part is 0.375 inch thick</p> <p>⑫ Nose cap<br/>Zirconium oxide 4000°F<br/>0.375 dia rods, 1 to 3 inches long</p> <p>⑬ Nose skirt<br/>Molybdenum 3000°F<br/>Machined from forging<br/>Part has 1.5 inch thick wall</p> |
|---|---|

Coatings

Columbium	LB-2
	Ti-Cr-Si (TAPCO)
Molybdenum	W-3 (Chromalloy)
Graphite	Siliconized (Nat. Carbon)

Material Designation

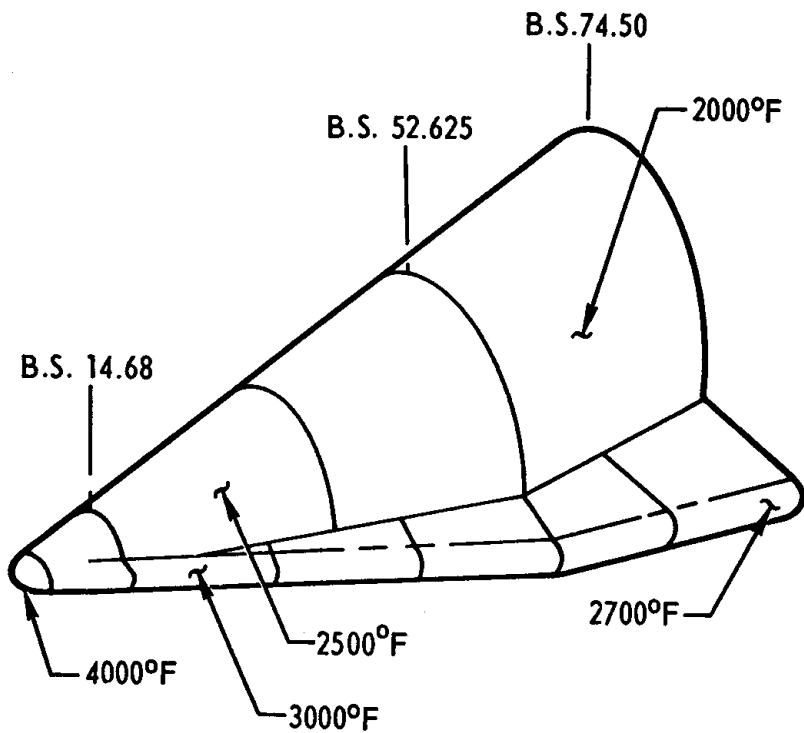
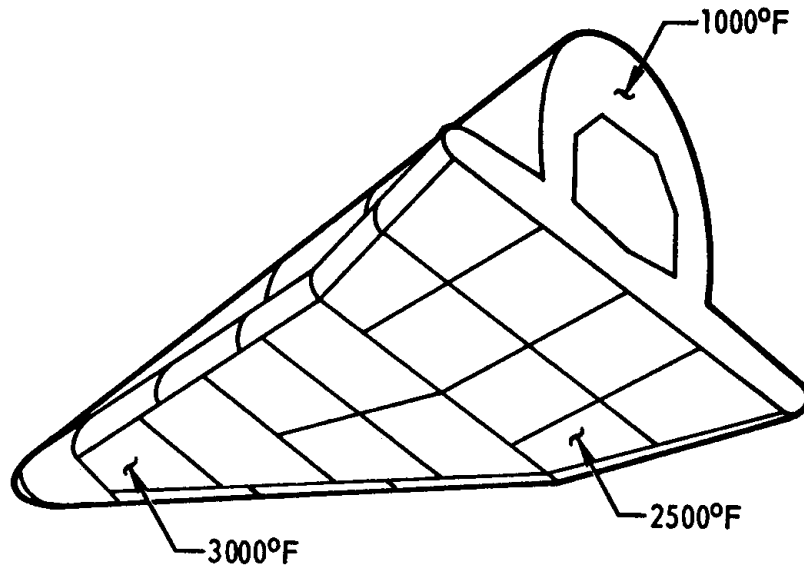
Columbium D-14	duPont
Molybdenum TZM	Climax
Graphite ATJ	National Carbon

Insulation Manufacturer

F-182 (Min-K)	Johns Manville Co.
Fiberfrax	Carborundum Co.
Refrasil A-100	H. I. Thompson Co.

(All temperatures are design temperatures and all dimensions are in inches.)

Figure 4



ASSET Summary of Maximum Design External Temperatures



# A E V    E X P E R I M E N T S

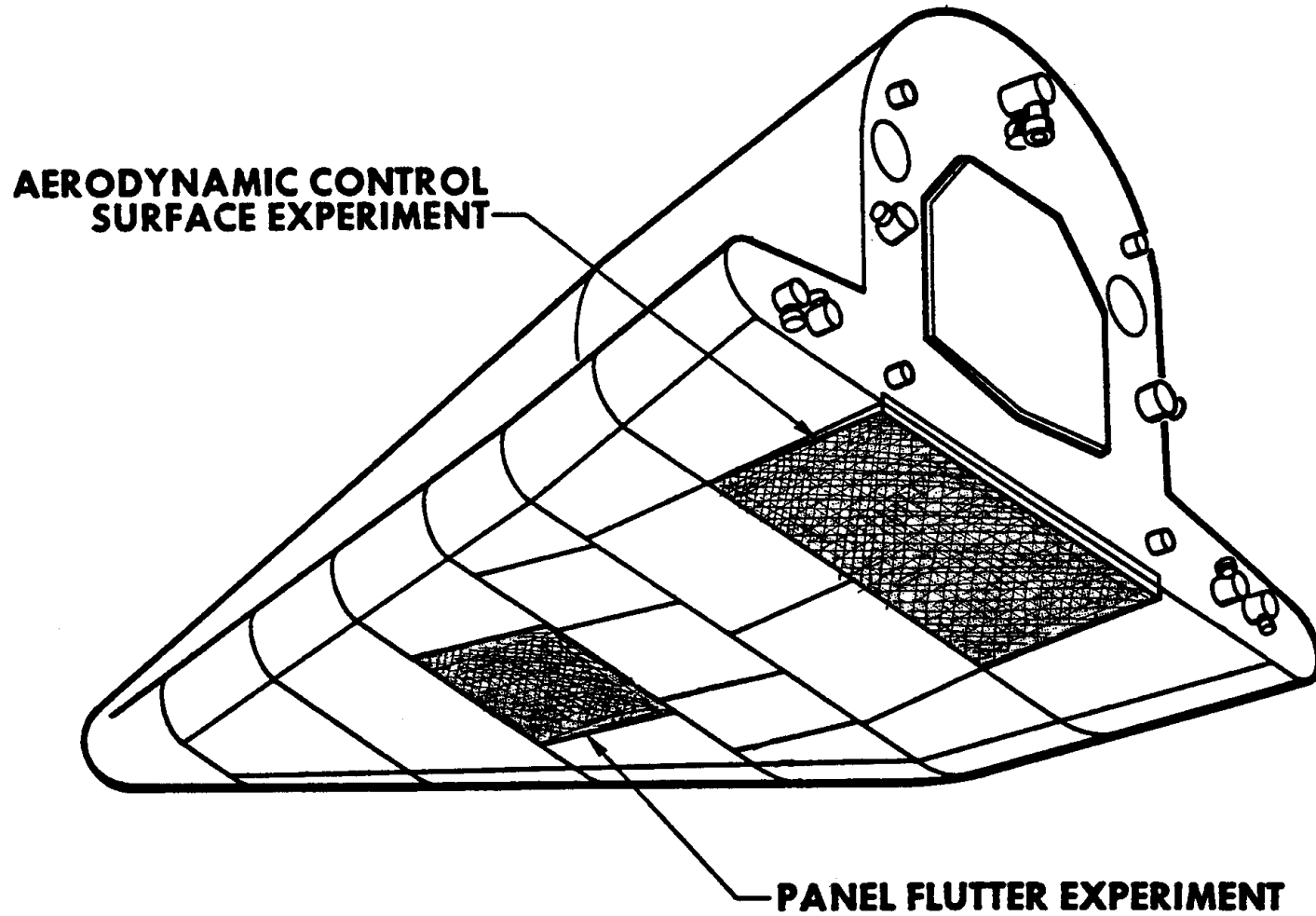


Figure 5

timing and switching functions as well. It consisted of a three-axis miniaturized rate integrating gyro (termed the MIG), a three-axis rate gyro system, pitch and roll programers, an intervalometer, poppet valve electronics, and amplifier units. The guidance package generated actual control of the ASSET vehicle through a reaction control rocket thruster system (RCS). While ASSET could not alter its trajectory by maneuvering off its flight path (as would, for example, the later PRIME), its reaction control thruster systems did permit altering its attitude. As with RCS technology flown on earlier rocket-propelled research aircraft such as the X-1B and X-15, and as with the contemporary Project Mercury spacecraft, the ASSET RCS consisted of a pressure-fed (using high-pressure nitrogen gas blowdown) monopropellant rocket system utilizing concentrated (90%) hydrogen peroxide passed over a catalyst generating high-pressure steam. ASSET's thrusters, located on the blunt back of the vehicle, generated roll, pitch, and yaw thrust vector inputs; the thrust levels could vary depending on the value needed to control the spacecraft. Generally speaking, after injection by the booster at an angle of attack ("alpha") of approximately zero degrees, the ASSET vehicle would aerodynamically "pitch" to its terminal glide attitude trim angle as dictated by the vehicle's center of gravity location and general aerodynamic shape. However, both AEV flights and ASV-4 (the final ASSET project flight) utilized a mercury ballast transfer system to change the glide trim pitch angle for aerodynamic pitch-up study and trajectory extension purposes. The guidance and control system incorporated a fixed yaw setting, so that the system constantly evaluated itself against this setting, and when it noted deviations, it signalled the RCS to fire the yaw thrusters thus restoring the spacecraft to its original setting. A pitch programer provided the necessary "torquing" rates for both the transition and glide phases of the flight, and the vehicle's roll programer furnished a single roll torquing rate to compensate and correct for roll errors induced by the rotation of the earth.<sup>22</sup>



ASSET's raison d'etre, of course, was its instrumentation systems - data sensing, commutation and telemetry, and tracking. The ASVs contained a variety of thermocouples, pressure taps, accelerometers, strain gauges, and other specialized monitoring and measuring instrumentation. This collection could measure a total of 133 physical parameters, consisting of forty surface temperature measurements, fourteen temperatures of substructure and equipment, thirty-three aerodynamic pressures, two miscellaneous pressures, four accelerations ("g") measured along the vehicle's normal (yaw) axis, lateral (pitch) axis, and two along the craft's longitudinal (roll) axis. The instrumentation could also acquire six structural deflection measurements, monitor twenty-two guidance and control functions, and collect twelve miscellaneous measurements (such as equipment voltages). On top of these, the AEV vehicles had additional instrumentation to record vibrations and a variety of other quantities directly related to the AEV's panel flutter and oscillating flap experiment. The AEVs had instrumentation to record the input force generated by the flutter panel's electromechanical "exciter," control surface displacement, hinge moments required to drive the control surface, oscillatory pressures, linear and angular structural displacements, and the vehicle's dynamic responses. These inputs were then electronically commuted at a sampling rate of 10 samples per second with exceptions for attitude indications and temperatures; attitude was recorded at 30 samples per second, and temperature at one sample per second. The commutator inputs then passed to the ASSET's telemetry system. The system on the ASV differed from that of the AEV because of the anticipated differences in ion-sheath formation characteristics between the two vehicles at reentry conditions. The ASV vehicles had two telemetry transmitters, one operating on VHF (237.8 Mc) and the other operating on X-band (9,320 Mc), the latter to overcome the loss-of-signal effects anticipated with the VHF system operating during periods of ion-sheath formation around the vehicle (the so-called "blackout" period typical of reentering

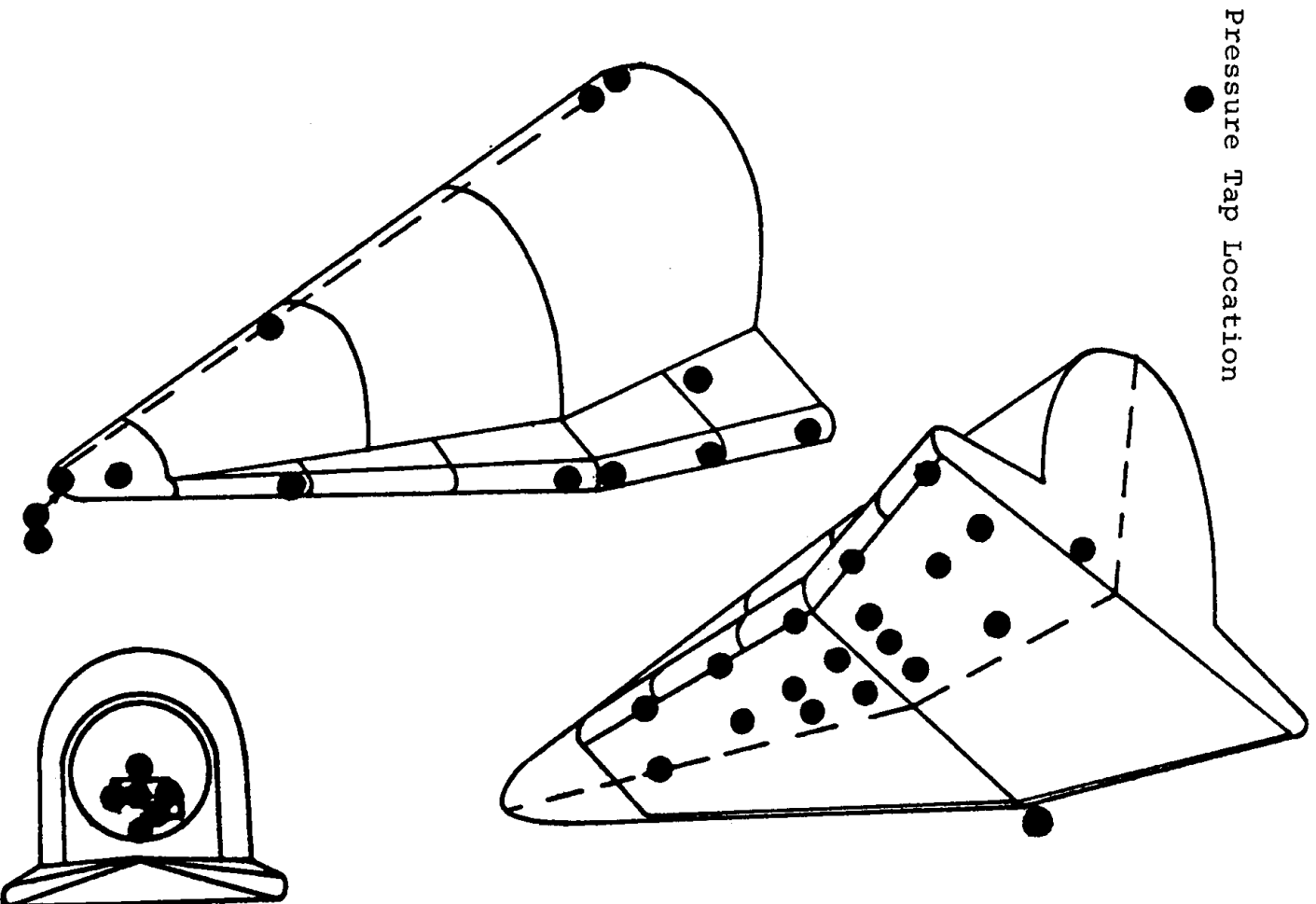
spacecraft). The VHF system was a so-called PDM/FM system, i.e.: a Pulse-Duration-Modulated keyer signal which, in turn, Frequency Modulated the carrier signal to the telemetry reception antenna. In contrast, the X-band transmitter was a PPM (Pulse-Position-Modulation) transmitter, equipped with a converter to change its initial PDM signal into PPM format. The ASVs also had an important back-up subsystem: an onboard magnetic tape recorder that could record the first 500 seconds of flight. It would play the tape via the PDM/FM downlink after the ASSET vehicle came out of the ion-sheath blackout. Further, it could itself be played back after ASSET recovery from the ocean, producing a quality record unmarred by the noise and transmission inaccuracies typical of telemetered materials. The lower velocity and lower altitude AEV ASSET vehicles did not require X-band telemetry since they would not encounter the ion-sheath problem. The AEVs used instead a 234 Mc VHF PDM/FM/FM system; the commuted data (PDM) frequency modulated onto one subcarrier oscillator for transmission to earth, while continuous information routed to additional subcarrier oscillators for transmission. Completing the information acquisition system was tracking. Radar tracking by ground-based FPS-16 radars on the Atlantic Missile Range furnished position and velocity data for the ASSET vehicles during their brief flights. To improve the chances of the FPS-16 picking up the speeding little spacecraft, the ASSET vehicles had a C-band radar transponder, which answered a 5,690 Mc interrogatory signal with a 5,765 Mc response. Even though calculations indicated that the ion-sheath envelope might black-out the transponder, researchers hoped the FPS-16 would still pick up the spacecraft since the ion-sheath itself would increase ASSET's radar return. VHF, X-band and C-band telemetry and tracking stations located at the Cape, Grand Bahama, Eleuthera, San Salvador, Mayaguana, Grand Turk, Puerto Rico, and Antigua would monitor ASSET as it sped along; finally, about 1700 n.m. downrange, the ASSET would move beyond land-based tracking and telemetry, and thus would be monitored and watched from a small fleet of specialized range vessels

and aircraft.<sup>23</sup> Figures 6 and 7, from the ASSET project's final briefing, show the location of the ASSET vehicle's pressure tap system (largely on the left side of the spacecraft), and its surface thermocouple system for heat measurement (largely on the right side of the vehicle).

ASSET's recovery constituted an important part of project planning, inasmuch as recovery would permit examination of the vehicle and access to the tape-recorded flight data. In practice, the ASSET recovery system saved the vehicle on only one of the three ASV flights on which it was used; the two AEVs were never intended for recovery, and simply fell into the ocean. (The circumstances of the losses will be discussed subsequently). The recovery system utilized a small drogue parachute for stability, followed by a second, larger chute for "soft-landing" the spacecraft in the Atlantic. As ASSET plunged into the lower atmosphere, decelerating to about Mach 1.5 at 85,000 feet, a barometric switch triggered a mortar located within the vehicle that fired the drogue chute, deploying it in a trailing position behind the aft bulkhead. The drogue slowed ASSET abruptly, and it dropped in a nose-down position until it reached an altitude of 25,000 feet. At that point, a second baroswitch fired the main parachute, double-reefed (i.e.: with an initial small canopy) to prevent it from shredding. At the same time, the switch triggered release of radar reflective chaff to highlight the impact area, and dropped a Sofar bomb from the spacecraft to detonate underwater and send a strong sound signal to waiting range vessels. After several seconds, the parachute would "de-reef" and open to a full canopy, slowing the vehicle appreciably; a Sarah radio beacon began transmitting to alert recovery forces that the ASSET was on its way to splashdown. At this point, a flotation bag popped from stowed position and inflated. The dense little ASSET drifted down to splash nose-first into the ocean, suspended on a tether from the flotation bag just below the surface, followed by triggering



Figure 6

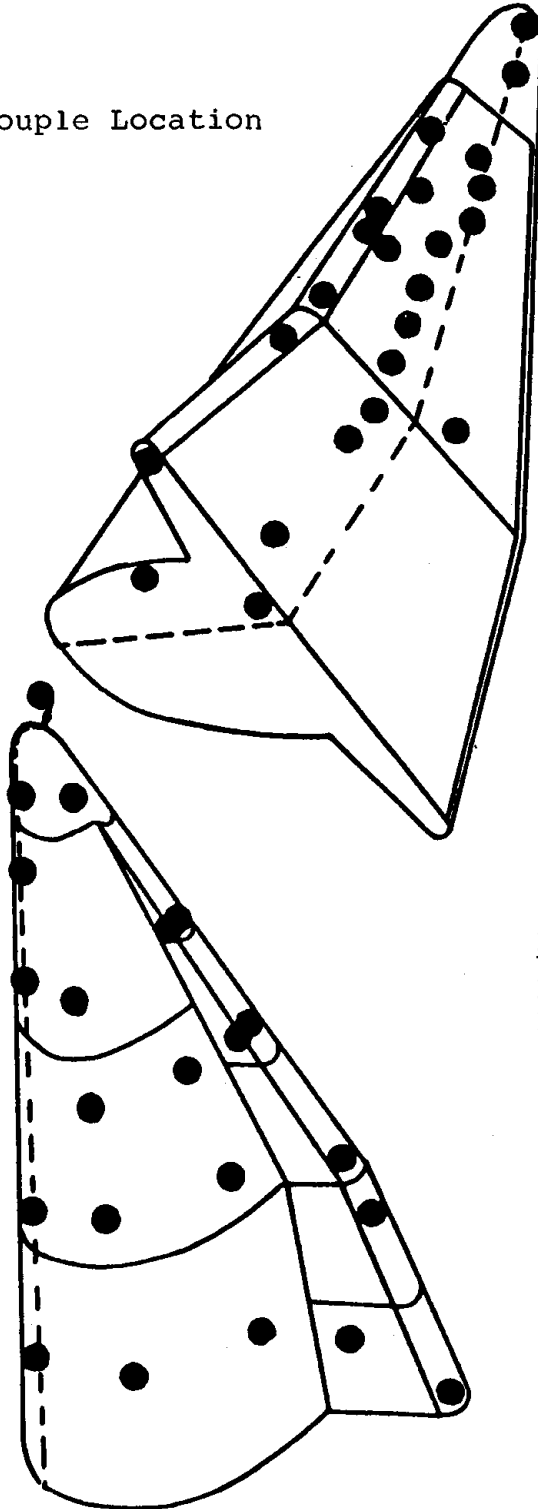


ASSET PRESSURE TAP SYSTEM



Figure 7

● Thermocouple Location



Location and Number

Nose Cap:	1
Nose Skirt:	3
Leading Edges:	10
Lower Surfaces:	11
Upper Surfaces:	11
Aft Bulkhead:	3

of a flashing strobe, a dye marker, and releasing shark repellent into the water, all to aid the recovery effort.<sup>24</sup>

Deliberate destruction of the ASSET should it stray from course or encounter some other difficulty constituted the flip side of the recovery process. ASSET required an automatic rather than a ground-commanded destruct system, since there were portions of flight--notably when an ionized sheath surrounded the vehicle--during which it could not receive a ground signal. Accordingly, the spacecraft incorporated a free gyro and electronics package connected to an explosive system containing Aerex, a new liquid explosive. If the gyro sensed that the ASSET vehicle had exceeded a bank angle of 30 degrees right (in practice, 25 degrees right) or 90 degrees left for more than 5 seconds, it would initiate a destruct sequence blowing the left wing off the vehicle. ASSET would enter a rapid and continuous roll, following a ballistic trajectory into the sea. If destroyed during boost, an interconnect system would blow both the ASSET and Thor's destruct packages. Naturally, "safetizing" the ASSET's destruct system assumed critical importance once recovery forces reached the small spacecraft. In practice, this only occurred once, with ASV-3. "Safing" checks primarily involved purging the Aerex explosive system and the onboard hydrogen peroxide tanks for the RCS system with fresh water. A four hour "bath" served to render the systems neutralized. Sad to say, the destruct system had a chance to prove it could work during staging difficulties on ASV-2; it functioned quite well, blasting the ASSET into the sea.<sup>25</sup>



## NOTES

1. USAF FDL, RTD, Advanced Technology Program: Technical Development Plan for Aerothermodynamic/Elastic Structural Systems Environmental Tests (ASSET) (Wright-Patterson AFB, OH: FDL, 9 Sep 1963), pp. 1-5. Hereafter ASSET Tech Plan.
2. Ibid., p. 3.
3. Ibid., pp. 27, 43-44.
4. Interview with W. E. Lamar, 18 Sep 1986; interview with A. C. Draper, 18 Dec 1986.
5. ASSET Tech Plan, pp. 43-44.
6. Ibid., p. 21; "Historical Effort," p. 1, attachment to McDonnell Aircraft Corporation Report A234, ASSET ASV-1 Preliminary Flight Test Report (St. Louis: McDonnell, 25 Oct 1963).
7. Ibid.; ASSET Tech Plan, pp. 21, 27, 89; ASD Historical Division, History of Aeronautical Systems Division, Jan-Jun 1962, III (Wright-Patterson AFB, OH: ASD, Dec 1962), p. III-28; interview with C. J. Cosenza, 8 Oct 1986.
8. USAF FDL, ASSET Final Briefing, 65FD-850 (Wright-Patterson AFB, OH: FDL, 5 Oct 1965), "ASSET Program Costs" table.
9. ASSET Tech Plan, p. 15.
10. Ibid., pp. 15-18.
11. S. A. LaFavor, "ASSET: A Program for Technology Development," paper presented at the Evolution of Aircraft/Aerospace Structures and Materials symposium, American Institute of Aeronautics and Astronautics, Air Force Museum, Dayton, Ohio, April 24-25, 1985. This statement is taken from the proceedings of the symposium, p. 15-5. See also "Historical Effort," pp. 1-2; ASSET Tech Plan, p. 97.
12. ASSET Tech Plan, Figure 3-1, p. 19. The figure has been modified to indicate the communication between FDL and McDonnell, and between SSD and Douglas.
13. ASSET Tech Plan, p. 3.
14. Ibid., pp. 8-9; M. H. Shirk, ASSET: Aerothermoelastic Vehicles (AEV) Results and Conclusions, 65FD-1197 (Wright-Patterson AFB, OH: FDL, Aug 1965), Fig. 3 and related text; Richard P. Hallion, On the Frontier: Flight Research at Dryden, 1946-1981 (Washington, D.C.: NASA, 1984), p. 116.

15. Shirk, Fig. 10 and related text.
16. ASSET Tech Plan, pp. 9-10.
17. ASSET Final Briefing, "Objectives and Contributions" table.
18. Ibid., "Approach" table.
19. ASSET Tech Plan, passim.
20. Adopted from Figures 2 & 3 (pp. 6-8) of J. C. Blome, J. C. Conti, and E. L. Rusert, ASSET; VII: Nonmetallic Materials Selections, AFFDL-TR-65-31 (Wright-Patterson AFB, OH: FDL Sep 1965).
21. Adopted from Figure 5-5, ASSET Tech Plan, p. 62.
22. ASSET Tech Plan, pp. 37-43; W. P. Zima, ASSET: Aerodynamic and Aerothermodynamic Results and Conclusions, 65FD-850 (Wright-Patterson AFB, OH: FDL, Jul 1965), text for Figures 1 and 3.
23. ASSET Tech Plan, pp. 37-42; Shirk, text for Figures 6 and 10; ASSET Final Briefing, "Data System" table; C. J. Cosenza and L. D. Huppert, "Project ASSET Glide Reentry Program," Proceedings of the Thirty-fourth meeting of the (Navy) Bumblebee Composite Design Research Panel, Orlando, Florida, 9 May 62, pp. 7-9.
24. ASSET Tech Plan, p. 41.
25. Ibid., p. 43. See also McDonnell Aircraft Corporation, ASSET ASV-3 Flight Test Report, B251 (65FD-234), (St. Louis: McDonnell Aircraft Corporation, rev. ed. 30 Mar 1965), p. 106.

## CHAPTER II

### ASSET: DEVELOPMENT AND FULFILLMENT

ASSET development necessitated unusually close cooperation between the FDL project office and McDonnell. Cosenza's management concept for the project depended upon establishing "informal, close relationships" with the contractor personnel--he personally worked closely with Cliff Marks, as mentioned earlier--and minimizing bureaucracy and paperwork. "We sought minimal documentation," he recalled emphatically nearly twenty-five years later. FDL had little contact with SSD, since SSD primarily involved itself with the booster development. This, interestingly, remained largely the case even after SSD assumed project management responsibility for ASSET after the cancellation of the X-20 program in December 1963. Only at the launch site did FDL and SSD have much interchange, and here a potential problem loomed, borne of the different philosophies within each organization. FDL carefully monitored downrange conditions, particularly sea states within the recovery area, since FDL desired to recover the ASSET vehicles for subsequent analysis. SSD, on the other hand, watched the launch site, seeing its function in life being one of getting boosters off launch pads in close to blue-skies conditions. After frank discussions, FDL managed to convince SSD that end-of-flight conditions were more important than those affecting launch.<sup>1</sup>

ASSET first flew in September 1963, three months before McNamara canceled the Dyna-Soar program. Interestingly, no formal technical interchanges had occurred between the X-20 and ASSET project teams, despite Cosenza's reasonable belief that the ASSET vehicle would have been of key importance to the X-20 effort, particularly in the area of insulation and radiative thermal protection systems structural design. Unlike Dyna-Soar, a carefully

planned aerodynamic configuration intended for lifting reentry, ASSET's designers emphasized its payload volume requirements rather than attempting to achieve an idealized aerodynamic shape. For his part, Cosenza had journeyed to Boeing to discuss the two programs, but as he recollected, "Boeing held their data very close . . . they didn't want to let on what they were doing on Dyna-Soar."<sup>2</sup> After December 1963, of course, ASSET moved to the front burner, as America's only lifting reentry vehicle in hardware and flight status; PRIME remained a creature of the future. But getting ASSET to the point where it flew had been no easy task, by any means.

The major difficulty facing the ASSET team--both the Air Force and McDonnell--involved developing reliable and realistic test apparatus and test conditions for refining the design of the craft. Just generating the right test environment was difficult enough; for example, though the temperature might be right, the structural loads or oxidation environment might be totally unrealistic. Thus, testing involved generating a lot more than just heat. Testing the zirconia nose cap for the ASSET, for example, ultimately involved achieving a maximum temperature of 4250 degrees F., using a rate of onset (the thermal shock) of 70 degrees F. per second, at an oxidizing atmosphere of 220,000 feet, and holding a +4000 degree F. temperature for 17 minutes. Sometimes the test equipment itself failed under such conditions. Tests of a proposed coated graphite nose cap for ASSET, for example, proceeded smoothly until the nose had reached a temperature of 3400 degrees F. Suddenly, a cooling hose burst, quenching the glowing test specimen with water; incredibly, the cap survived the abrupt thermal shock, a marked tribute to its design.<sup>3</sup>

What ASSET offered--which PRIME could not--was reliable heat transfer data for hypersonic reentry as a result of using a "hot" radiative-cooled flight structure. PRIME, being ablatively

cooled, could not furnish such information, due to the ablation process itself. PRIME was thus a project to examine whether a lifting reentry spacecraft could maneuver through the atmosphere, whereas ASSET involved acquiring flight experience with a high temperature structure representative of that of future spacecraft. Developing ASSET required generating highly realistic test environments in which the craft's structural design concepts could be evaluated. The lack of reliable high-temperature instrumentation, particularly thermocouples, posed a serious challenge to ASSET's developers, forcing design of new and complex equipment. Also--a bigger problem--available wind tunnels offered little hope of adequately simulating the ASSET vehicle's hypersonic environment. In the higher Mach regions, the tunnel facilities simply lacked the fidelity designers needed to adequately rely upon them for future hypersonic design. As Cosenza recalled, highlighting but one of many problems, "We didn't have--and could not have--an appreciation or understanding of the magnitude of upper surface heating. When you get above Mach 6 or 8, you have grave difficulties matching the real-world environment."<sup>4</sup> (Hypersonic tunnels dated to 1945. Amidst the rubble of Nazi Germany, technical investigators discovered a 1 meter by 1 meter hypersonic tunnel under construction at Kochel, in the Bavarian Alps; it formed the basis for the inspiration and ultimate construction of hypersonic test facilities at the Arnold Engineering Development Center and these facilities played a major role in ASSET development. For its part, the NACA had built its own tentative hypersonic tunnels starting in 1945 at Langley with a design by John V. Becker, and at Ames, using a design by Alfred J. Eggers).<sup>5</sup> One of ASSET's significant contributions would be its comparison of "real-world" data from the fringes of the upper atmosphere with data from tunnels on earth; in those comparisons the tunnels were often off by significant amounts. Thus ASSET offered a unique chance to "calibrate" ground test facilities.<sup>6</sup>

ASSET's test schedule dominated other aspects of the development program; wind tunnel testing commenced as early as

September 1961, in advance of the actual vehicle design. Figure 8 lists the test type, facilities utilized, and start-up date for the tunnel testing accomplished in support of the ASSET program. As can be seen, ASSET testing involved far more than merely the contractor and the Air Force. Ultimately, ASSET's developers utilized Navy, NASA, Air Force and private (Cornell and McDonnell) facilities.<sup>7</sup>

Analog and digital computer studies of stability and control, flight conditions (notably the transition from boost to glide phase, and trajectory analysis), and both structural and non-structural temperatures and loads complemented wind tunnel studies. These included McDonnell structural temperatures program run on an IBM 7090 digital computer that examined various modes of heat transfer, including conduction, convection, external radiation to space, internal radiation to surrounding structural elements, interface conductance, and heat storage.<sup>8</sup>

As shown in Figure 3, ASSET made use of a variety of commonplace and exotic metallic and non-metallic structural elements. Though in general the Air Force and McDonnell found they could rely upon vendor data, disturbing cases existed where tests of some materials proved that the data vendors supplied was sometimes in error. FDL and McDonnell made it a practice to test all refractory metals in both coated and bare conditions at various temperatures in order to properly assess strength retention and oxidation resistance properties. Nonmetallic materials--such as the refractory oxide ceramics, graphite, and thermal insulation materials--required extensive testing. ASSET made use of nonmetallic structural materials such as the above because at the temperatures expected of ASSET, protective coatings for refractory metals would break down. Ceramics and graphite were needed for temperatures above 3000 degrees F., and dielectric ceramics were needed for high-temperature antennas. Here ASSET broke new ground, for it was the first aerospace vehicle that demanded the use of these materials for applications such as leading edges and

Figure 8

## ASSET WIND TUNNEL TEST PROGRAM

<u>Test</u>	<u>Facility</u>	<u>Date</u>
Hypersonic Pressure	AEDC von Kármán Tunnel C	10/61
Hypersonic Pressure	Cornell Aero Lab 48 in. Shock Tunnel	10/61
Transonic Static Force & Moment	McDonnell Polysonic Wind Tunnel	11/61
Supersonic Static Force & Moment	McDonnell High Impulse Tunnel	9/61
Supersonic Static Force & Moment	Naval Ordnance Lab Tunnel #1	2/62
Supersonic Pitch Damping	Naval Ordnance Lab Tunnel #1	2/62
Hypersonic Static Force & Moment	AEDC von Kármán Tunnel C	10/61
Hypersonic Static Force & Moment	Cornell Aero Lab 48 in. Shock Tunnel	11/61
Hypersonic Static Force & Moment	Naval Ordnance Lab Tunnels #4 and #8	5/62
Hypersonic Pitch Damping	Naval Ordnance Lab Tunnel #4	5/62
Hypersonic Free Flight Stability	Naval Ordnance Lab Tunnel #3	7/62
Hypersonic Free Flight Stability	Naval Ordnance Lab Ballistic Range	7/62
AEV Pressure Model	AEDC von Kármán Tunnels A, B, and C	2/63
AEV Pressure Model	McDonnell Polysonic Wind Tunnel	12/62
AEV Phase I Heat Transfer	AEDC von Kármán Tunnel C	4/63
AEV Phase I Heat Transfer	NASA Langley 7 in. Blowdown	3/63

(continued on next page)

Figure 8 (cont.)

ASSET WIND TUNNEL TEST PROGRAM

<u>Test</u>	<u>Facility</u>	<u>Date</u>
AEV Phase II Heat Transfer	Cornell Aero Lab 48 in. Shock Tunnel	4/63
AEV Panel Flutter Series I	Ames Research Center hypersonic tunnel	11/62
AEV Panel Flutter Series II	Ames Research Center hypersonic tunnel	10/63
AEV Panel Flutter Series II	Lewis Research Center hypersonic tunnel	12/63



the vehicle's nose cap. ASSET further demanded thermal insulation materials to keep the internal structure and equipment isolated and insulated from external heating. Though thermal insulation "blankets" made from flexible fibers could meet much of the latter requirement, ASSET did need a limited amount of ablative materials for the wing upper surface and interstage for protection during boost phase heating. Again, the characteristics and expected performance of all these materials demanded thorough and rigorous ground testing prior to flight.<sup>9</sup> Figure 9 is a table summarizing the ASSET structural ground test program, and is adopted from the ASSET Tech Plan (Table 5-1).

For the most part, the tests went smoothly, and validated the expectations of ASSET designers. However, several cases did reveal difficulties and disappointments. For example, tests of a molybdenum panel with a Pfadler coating resulted in widespread oxidation and embrittlement of the material. In another case, researchers designed a hypersonic aerodynamic flow "rake" that would protrude into the airstream below the ASSET AEV vehicle to support the data acquisition effort from the AEV panel flutter experiment. They followed two different approaches and evaluated the resulting test specimen in the McDonnell Arc Plasma Jet Facility at temperatures up to 5000 degrees F. One approach utilized a rake fabricated from thorium oxide (commonly called thoria), a substance known to be thermally shock resistant and thus potentially useful on the ASSET vehicle. However, thoria also has a high permeability to gases, and researchers discovered that leakage would distort any flow readings taken by the rake. Finally, during testing, the thoria specimen cracked while cooling down from a 5000 degree F. exposure. The second approach involved using a rake fabricated from hafnium oxide, but the coarse-grained hafnia specimen did not survive the thermal shock test using the McDonnell plasma jet. After these two disappointing experiences, researchers abandoned attempts to produce a hypersonic rake for ASSET.<sup>10</sup>



Figure 9

ASSET STRUCTURAL GROUND TEST PROGRAM

<u>Test</u>	<u>Purpose</u>	<u>Facility</u>
Upper Body Proof Load	Determine critical boost phase pressure loading	McDonnell Static Test Laboratory (MSTL)
Panel Edging	Substantiate edging design approach taken on Columbia and Molybdenum panels	McDonnell Radiant Heat Facility (MRHF)
Bulkhead Proof Test	Determine critical boost phase loads	MSTL
Leading Edge Heat	Substantiate adequacy for expected temperature environment	RTD Radiant Heat Facility McDonnell Oxyacetylene Torch Facility (MOTF)
Leading Edge Load	Determine critical boost phase loads	MSTL
Leading Edge Vibration and Sonic Fatigue	Determine critical boost phase environment	McDonnell Dynamics Laboratory (MDL)
Nose Cap Heat	Determine most suitable type of construction and substantiate its adequacy for expected temperature environment	McDonnell Arc Plasma Jet Facility (MAPJF) and MOTF
Nose Cap Load	Determine critical boost phase loads	MSTL
Nose Cap Vibration	Test at critical boost and glide environments	MDL
Floor Joint Test	Evaluate adequacy of shear joints utilizing an insulating spacer	MSTL

Figure 9 (cont.)

## ASSET STRUCTURAL GROUND TEST PROGRAM (cont.)

492

<u>Test</u>	<u>Purpose</u>	<u>Facility</u>
Temperature and Vibration Effects on Refractory Lock Nuts	Determine appropriate torque values to ensure locking of nuts	MOTF
Nose Cap Sonic Fatigue	Determine capability of proposed graphite and ZrO <sub>2</sub> nose caps to withstand anticipated noise environment	MDL
Molybdenum Lower Panel Sonic Fatigue	Demonstrate adequacy of panel to survive anticipated noise environment	MDL
Molybdenum Panel--Boeing Coating Heat Test	Substantiate coating integrity	MRHF
Molybdenum Panel--Pfaudler Coating Heat Test	Substantiate coating integrity	MRHF
Hypersonic Rake Heat Test	Evaluate materials for rake design	MAPJF
Coated Molybdenum Materials Test	Establish design allowables for coated materials	MRHF
Coated Columbium Materials Test	Establish design allowables for coated materials	MRHF
Oxidation Check Tests on various components	Check coating methods for proper oxidation protection	MRHF
Combined Structural Test	Simulate flight temperature environment on structure, insulation, and instrumentation, and to test lower panels for critical boost loads	MRHF

Developing ASSET's nose cap and graphite and molybdenum components posed special challenges that rigorous design and testing procedures successfully overcame. Eventually, ASSET vehicles flew with two different nose caps, one fabricated from blocks and rods of zirconium oxide ( $ZrO_2$ ), and the second utilizing a tungsten nose cap coated with thorium nitrate-bonded thorium ( $ThO_2-W$ ). A third, extensively lab tested but not flown, was a siliconized graphite cap coated with zirconium oxide; it proved unsatisfactory, with pronounced cracking, blistering, and some flowing of the coating. Technicians machined the zirconium oxide blocks and rods used for the "solid"  $ZrO_2$  nose cap, shaped them to fit together, and then assembled them. They filled gaps between the shaped rods and blocks with a zirconia "cement" consisting of zirconia particles in a liquid binder. This paste, forced between the rods and blocks to fill the interstices in the nose cap, cured at 600 degrees F. and set the material. Unfortunately, none of the ASSET vehicles with the  $ZrO_2$  nose cap survived for postflight examination. Available flight data--as well as the indisputable fact that these craft successfully traversed the hypersonic region down to recovery conditions--indicate that the caps functioned well, however.<sup>11</sup>

The graphite and molybdenum components had their own peculiarities. Like the nose, the leading edges of the ASSET vehicle would sustain extremely high temperatures over an extended period of time. Unlike the nose, where temperatures on the order of 4000 degrees F. could be expected, the leading edges would encounter lower temperatures of about 3000 degrees F. ASSET's design team decided to fabricate the rounded leading edges from graphite for the forward sections nearest the nose, and from a columbium alloy containing one percent zirconium for the aft portions near the blunt back end of the vehicle. Designers had not previously utilized graphite as a major structural component for advanced aircraft, and the state of the technology in 1961-1963 was by no means as advanced as when Space Shuttle's designers made

use of it over a decade later, in the mid 1970s. Then, composite structures technology had advanced to the point where industry could fabricate composite carbon-carbon graphite structural elements. The graphite of ASSET, however, was a non-composite cast-like structure and very brittle. The particular graphite material used on ASSET was a kind termed ATJ, an extremely fine-grained material having uniform density and a low ash content, and treated with a siliconized coating. As might be expected, finished structural elements formed from the graphite were difficult to inspect due to the absence of non-destructive test methods. Additionally, the inherent brittleness of the material led to frequent installation breakage particularly of thin sections. The complexity of working with the graphite is evident in an extract from a summary report on ASSET's use of nonmetallic structural elements:<sup>12</sup>

The forward leading edges for ASSET were machined from selected ATJ graphite stock and coated. The selection of acceptable billets was accomplished by trimming all billets and X-ray inspecting the trimmed blocks. A density check was also made at this time. After the parts were machined, radiographic and visual inspections were performed prior to shipment to the vendor for coating. After coating, the parts were thoroughly inspected, including an oxidation check test at 2200 degrees F. for 1 hour. The SiC coated leading edges were then flame sprayed with ZrO<sub>2</sub> at the shiplap joints to meet the dimensional requirements . . . The instrumentation holes in the leading edges accepted a ZrO<sub>2</sub> tube which was cemented in place with a chemically bonded ZrO<sub>2</sub> cement. The ZrO<sub>2</sub> tubes in turn received either a sheathed thermocouple or were connected to a pressure tube.

Successful qualification of full-scale leading edges was completed at Wright-Patterson AFB, Ohio. It was accomplished primarily by heading the part to the ASSET design temperature-time profile maximum temperature of approximately 3000 degrees F. Quartz lamps were used as the heat source . . . Some thermocouples were attached to the back side of the leading edge with flame sprayed ZrO<sub>2</sub> and other thermocouples were installed using the sheathed design and ZrO<sub>2</sub> tubes as described above. Coated molybdenum and columbium fittings clamped the

graphite part . . . and simulated the installation on the vehicle.

Cosenza and the ASSET design team at McDonnell anticipated that the use of refractory materials and superalloys on ASSET would provide significant information for the subsequent design of lifting reentry vehicle, and this expectation did, in fact, prove accurate. Much as the X-15 program advanced the use of Inconel alloy, and the A-12/YF-12A/SR-71 spawned understanding and use of titanium, ASSET established manufacturing technology to transform these exotic materials into structural elements for actual flight vehicles. Generally, ASSET's use of such materials as molybdenum and columbium revealed four major problems: fracturing during forming because of brittleness; inability to produce structurally sound welds; material delamination during cutting and sawing operations, or even rough by rough handling; and difficulty of applying oxidation-resistant coatings. Eventually, all of these were overcome (particularly with molybdenum), but they did hint of continuing problems on future programs where designers expected to use these materials. "Moly" processing demanded rigid handling procedures, techniques for chemical milling, electrochemical etching and vibration deburring, and "hands-on" hand treating to dress part edges for adequate protective coatings. Columbium did not demand such exotic procedures, and manufacturers could utilize conventional blanking and forming methods.<sup>13</sup>

In addition to structural elements such as ceramics and superalloys, ASSET's design required application of insulation materials both on the inside and external surfaces of the vehicle. ASSET ultimately used both "passive" and "active" insulation materials and methods. Designers employed passive methods (primarily involving insulation blankets) for four specific applications: insulating the internal structure from the lower heat shields; insulating the internal structure from the upper body; insulating equipment from the internal structure; and incorporating structural insulating spacers. Active methods involved applying Teflon

ablative coatings to the upper surfaces of the wings, and a heat-shield insulating surface for the "interstage" between the Thor booster and the ASSET vehicle consisting of DC-325 insulation in a phenolic-Fiberglas honeycomb matrix. The active methods could not provide any sort of reentry protection, but, rather, protected the interstage and ASSET's wing structure from anticipated high heating during the brief boost phase prior to separation of ASSET from the Thor and the initiation of its hypersonic gliding reentry. Figure 10 gives details on ASSET vehicle insulation protection, including details on the structural insulating spacers utilized to eliminate heat "shorts" at structural attachment points; only one spacer material, CS-1000, proved suitable.<sup>14</sup> ASSET's insulation system completed creation of a vehicle that essentially blended a "hot compliant" external structure with an insulated and "cold" internal structure surrounding the spacecraft's equipment and instrumentation.<sup>15</sup>

AEDC testing indicated the ASSET vehicle would encounter about one minute of extreme heating (with a heat flux rate eventually reaching approximately 90 BTUs per square foot per second) during the boost phase. The temperatures generated would exceed the permissible heat limit of the single-face corrugated L-605 brazed cobalt alloy panels (a limit estimated at 1800 degrees F.). Designers pursued three options: redesign using a higher temperature structure, water "blankets" under the panels, and, finally, applying an ablative coating to the top of the L-605 panels. The latter seemed the easiest to accomplish, and following competitive trials between Teflon, DC-325, and a Refrasil phenolic reinforced silica-cloth laminate, McDonnell selected Teflon because it "sublimes" as it ablates, leaving a relatively clean and smooth surface. The other two, left heavy and flow-obstructing char residues. Depending on the particular ASSET mission, technicians applied Teflon coating in varying thicknesses. For the first ASV-1 flight, only .10 in. of Teflon sufficed; the more demanding



Figure 10  
ASSET Vehicle Insulation Location

Insulation material	Temperature range (°F)	Vehicle location	Insulation type	Facing	Thread
Refrasil A-100	1500-2500	Between floor and lower heat shields Upper body  Behind leading edges Side beams Wing stubs	0.25 inch thick  0.19 inch thick blanket	Refrasil C-100-38	Refrasil YT-100
Refrasil	100-1100	Aft bulkhead	0.25 inch thick blanket	No. 126 fiberglass cloth	E12 or E18 fiberglass thread
Refrasil	1500-2500	Upper body ② (between blankets and stringers)	Loose batt	None	None
Fiberfrax paper	2000-2400	Lower wing stub surface	0.080 inch thick paper	None	None
	2500-3000	Lower body against heat shields	0.080 inch thick paper	None	None
Min-K 2000 ①	1200-1900	Upper body	0.25 inch thick blanket	Refrasil C-100-38	Refrasil YT-100
Min-K 2000	1300-2000	Wing stub	Various size molded blocks	None	None

Figure 10 (cont.)  
**ASSET Vehicle Insulation Location**

Insulation material	Temperature range (°F)	Vehicle location	Insulation type	Facing	Thread
Min-K 1301 <sup>①</sup>	100-1600	Inside body on floor Side beams Upper body	0.25 inch thick blanket	No. 126 fiberglass cloth	E12 or E18 fiberglass thread
	100-1300	Wing stub	Various size molded blocks	None	None
Min-K 1301 <sup>①</sup>	1100-1500	Lower body <sup>③</sup> between floor and heat shields  Upper body <sup>③</sup>	0.25 inch thick blanket	No. 126 fiberglass cloth on cool side and Refrasil C-100-38 on hot side	Refrasil 4T-100 thread and fiberglass E12 or E18 thread  E12 or E18 fiberglass thread

Notes:

- ① On ASV-2 and up special flexible Min-K F-182 was used as a replacement for flexible Min-K 2000 blankets and Min-K 1301 blankets.
- ② Void spaces were filled with loose batt to reduce radiation.
- ③ The blankets were installed in a manner such that the C-100-38 Refrasil cloth was on the hot side and the No. 126 fiberglass cloth on the cold side.

Figure 10 (concluded)  
Structural Spacer Materials

Material	Thermal properties			Physical properties			
	Temperature limit (°F)	Thermal conductivity	Thermal shock resistance	Density	Vibration resistance	Compressive strength	Comments Notes
Min-K 2000	2000	Very low	Good	Low	Poor	Low	③ ⑤
Fiberfrax board	2500	Intermediate	Good	High	Good	Intermediate	③
Zirconia foam	2400 ①	High	Poor	High	Poor	Low	③ ⑤ ⑨
Alumina foam	2400 ①	High	Poor	High	Poor	Low	③ ⑤ ⑨
Reinforced plastics	500	High	Good	High	Good	High	⑧ ⑨
Powders in metal foil	②	High	Good	Low	Good	High	④
Metal honeycomb filled with powder	②	High	Good	Low	Good	High	④
Faced fibrous batts	2000	Low	Good	Low	Poor	Low	③ ⑨
Tipersul impregnated with colloidal silica	1800	Low	Good	Low	Poor	Intermediate but nonuniform	③ ⑤
Asbestolux	1000	High	Poor	High	Good	High	⑧
DC-325	800	Low	Good	Low	Good	Low	⑧ ⑨
CS-1000	2000 ⑥	Low	Good	High	Good	Very high	⑦

Notes:

- ① Excessive shrinkage occurs during initial heating to a higher temperature
- ② Dependent upon metal employed
- ③ Fragile
- ④ Development required
- ⑤ Poor fabrication qualities

- ⑥ Short time temperature higher
- ⑦ Acceptable material for ASSET use
- ⑧ Limited because of temperature
- ⑨ Limited because of strength

CS-1000 selected as primary spacer material in light of the above properties of competitive materials; aside from CS-1000, Tipersul came closest to meeting ASSET's requirements.

ASV 2, 3, and 4 required .40 in., however.\* Interstage protection involved "gloving" a low-heat-resistant aluminum structure (essentially a short truncated cone joining the Thor to the ASSET vehicle with the previously discussed heat shield composed of DC-325 in a honeycomb matrix). Cell-size measured .187 in., and the structure had a core density of 7 lbs. per cubic foot. Tests using an oxyacetylene torch, and subsequent flight experience indicated that the interstage thermal protection system functioned most satisfactorily.<sup>16</sup>

Being radiatively cooled, ASSET required an external structure possessing high thermal emittance, so that energy absorbed from aerodynamic heating as it plunged through the atmosphere could dissipate. On the other hand, ASSET's internal structure required low emittance (i.e.: high reflectivity) to reflect the radiant energy emitted by higher temperature surfaces. These diverse requirements resulted in some interesting technical solutions. For example, the VHF antenna for telemetry transmissions demanded a high temperature and high emittance coating that would not interfere with transmission characteristics. Engineers initially considered a black ceramic coating used on the Project Mercury spacecraft, but rejected it when tests indicated that it would interfere with the antenna. Another black coating, consisting of an aluminum phosphate-bonded black oxide posed no dielectric difficulties during testing at 1800 degrees F. and a simulated atmosphere of 200,000 feet. Subsequently, designers placed a silica glass antenna "window" over the aluminum oxide antenna body for improved thermal and electrical performance. Coated with the aluminum phosphate-bonded black oxide, this window functioned well over a thermal emittance range from approximately .78 at 1000 degrees F. to about .87 at 2700 degrees F. Internal surfaces

---

\*Ablative coating thickness is governed by the equation for the effective heat of ablation:

$$Q^* = 750 + 0.44 (H_{stag} - H_{wall})$$

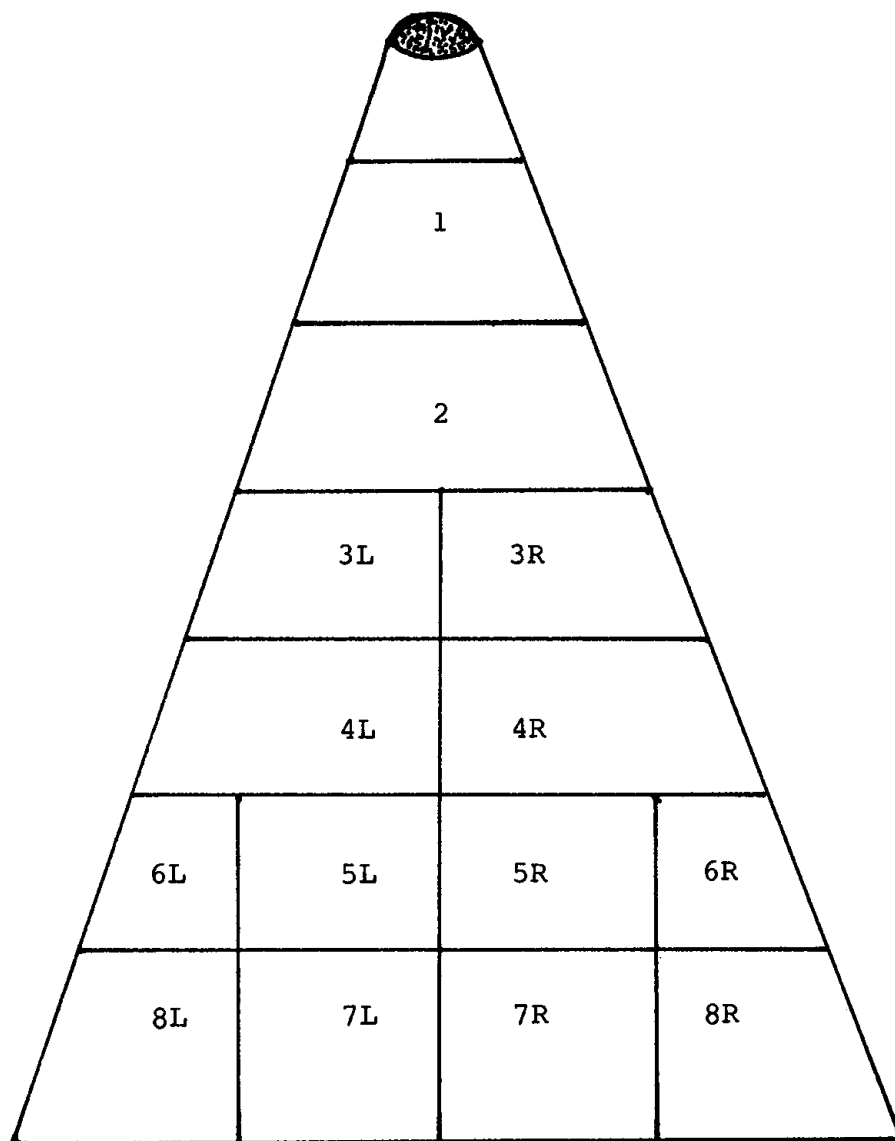
where H = enthalpy and Q\* = effective heat of ablation

received application of a special heat conversion gold coating furnished by Engelhard Industries, a lustrous finish utilized previously on the Mercury program and also on Gemini as well. The emittance range of heat conversion gold varied from .1 to .15 when applied to columbium, molybdenum, and CS-1000 aluminum insulation, and from .05 to .1 when applied to heat-oxidized stainless steel and aluminum.<sup>17</sup>

As planned, investigators used the ASSET spacecraft for carrying full-size structural components, and the ASV (and one AEV) vehicles flew with special materials and structural tests furnished by four manufacturers. Three--Boeing, Bell, and Martin--built test panel installations. The fourth, the Solar Aircraft Company, built a special (and previously discussed) tungsten-thoria nose cap. Figure 11 shows a schematic view of the ASSET vehicle's underside, giving panel locations (as seen from inside the spacecraft) and referencing the various manufacturers of these items and the ASV/AEV vehicles on which they flew. Research work previously authorized under the eventually-defunct X-20 Dyna-Soar development effort spawned some of this experimentation. For example, Boeing produced four coated molybdenum panels using their fluidized bed processing technique developed for the X-20, and flew them on ASV-1 and ASV-3. Bell produced samples of their proposed double-wall "active" cooling system (an idea dating to that firm's own Dyna-Soar work when Bell competed with Boeing for design of the proposed orbiter). The Bell system consisted of two columbium alloy (D-14) panels coated with LB-2, an internal insulated package containing submicron powder (ADL-17), an integrally tubed skin "floor" to permit circulation of a coolant mixture of propylene glycol and water, coolant reservoirs, and a coolant pump. This system flew on the ill-fated ASV-2 and ASV-3. Martin manufactured two brazed columbium (D-36) heat-shield panels on



Figure 11



<u>Company</u>	<u>Test Item</u>	<u>Vehicle</u>
Boeing	Panels 1 & 4R	ASV-1, ASV-3
Bell	Panels 7L & 7R	ASV-2, ASV-3
Solar	Nose Cap	ASV-3, AEV-1
Martin	Panels 7L & 7R	ASV-4

Note: Panel designations are as panels are seen from the inside of the ASSET vehicle.

ASV-4 in support of a contract with the FDL and Air Force Materials Laboratory at Wright-Patterson AFB. These panels consisted of a columbium honeycomb "sandwich" brazed with B-120 VCA titanium alloy, and then coated with a TRW-developed Cr-Ti-Si coating. Unfortunately, the loss of ASV-4 during recovery prevented postflight examination of this concept. ASV-3, carrying Bell, Boeing, and Solar experiments, not only carried more of these experiments than any other ASSET vehicle, but fortunately was the most productive as well, as recovery forces managed to retrieve it before it came to harm.<sup>18</sup>

As the end of the summer of 1963 approached, ASSET at last constituted a reality. McDonnell technicians had the first of the small, densely packed hypersonic gliders in final systems checkout before shipping it to the Cape for its first flight. Then, with surprising swiftness, ASSET moved into flight test, carrying with it the hopes and expectations of its developers.

#### Fulfillment

Flight testing has always marked both a culmination and a beginning for aerospace programs. On one hand, a program leaves the drawing board for the sky. On the other hand, oftentimes the real challenges are confronted when one is actually flying hardware and not "paper" aircraft. With one exception--ASV-2--ASSET's flight program moved smoothly along. Following traditional flight test philosophy, each ASSET mission was generally more demanding than its predecessor; similarly, each mission typically resulted in a cautious incremental opening of the vehicle's "envelope" to higher speeds and more demanding reentry conditions. The initial test plan called for four flights by the ASV vehicles, followed by two of the AEV craft. Planned criteria for the missions were as follows, though these changed somewhat and final flight values differed as well:



<u>Mission</u>	<u>Booster</u>	<u>Velocity</u>	<u>Altitude</u>	<u>Glide Angle</u>	<u>Range</u>
ASV-1	DSV-2F	16,000 ft./sec.	205,000 ft.	38 deg.	987 n.m.
ASV-2	DSV-2G	18,000	195,000	20	1,800
ASV-3	DSV-2G	19,500	225,000	38	1,830
ASV-4	DSV-2G	19,500	206,000	20	2,300
AEV-1	DSV-2F	13,000	168,000	20	830
AEV-2	DSV-2F	13,000	187,000	38	620

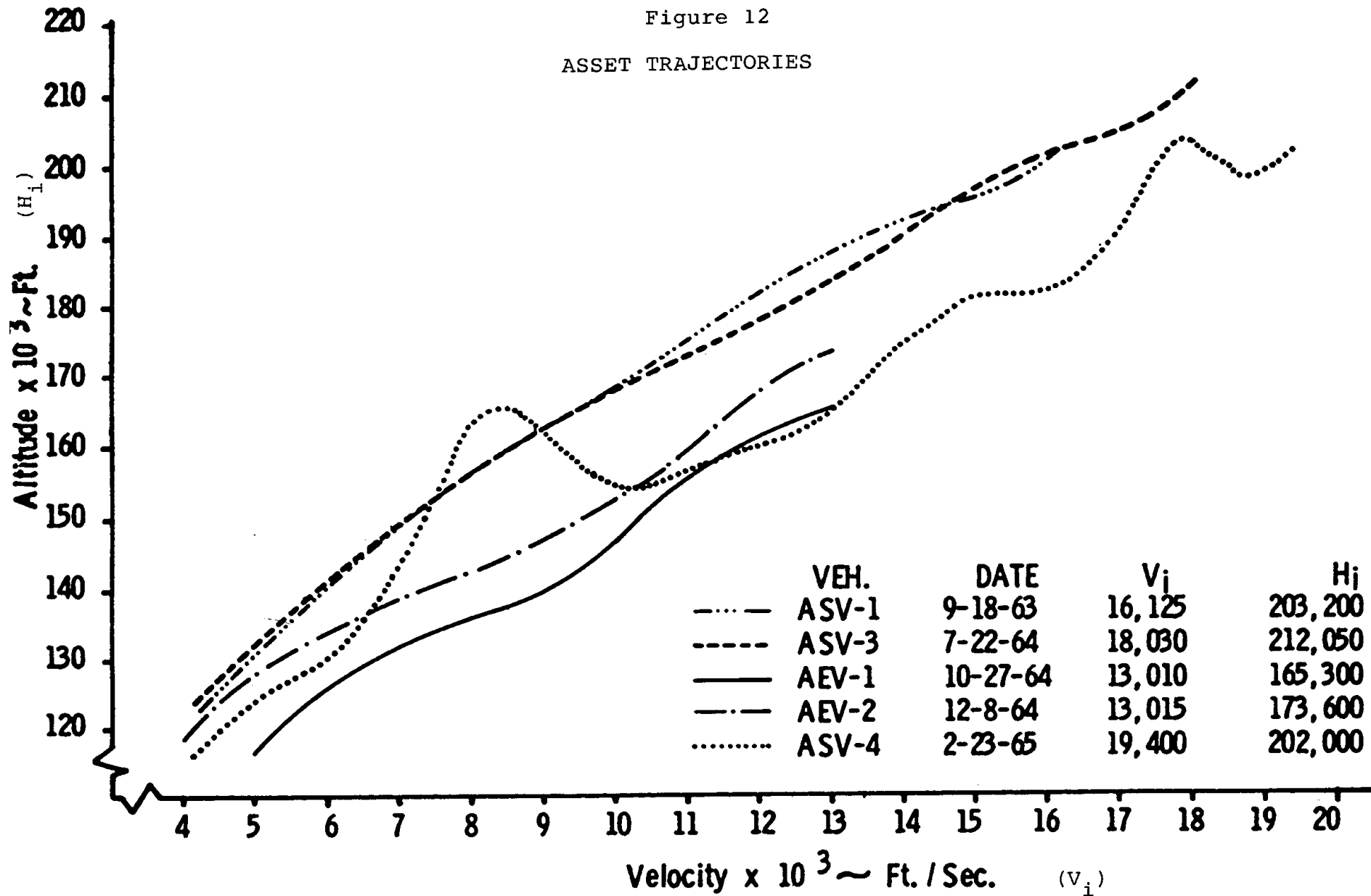
In actuality, as will be discussed, an approximately five percent range error in predictions plagued the flights, which led to shorter-than-planned missions; some of the planned ranges were subsequently changed, as well. Further, "Glide Angle" requires a quick clarification. This angle, more precisely termed the glide trim angle of attack, resulted from the combination of the ASSET vehicle's inherent aerodynamic characteristics and its center of gravity location. The above figures refer to the glide trim angle as measured on the centerline of the vehicle. The glide trim angle itself was the angle of attack for the fixed flap portion on the vehicle's underside. The tilted ramp ahead of this portion would, of course, add an additional 10 degrees to the above figures. Figure 12, based on ASSET Final Briefing data, gives a plot of trajectories for the ASSET vehicles as measured during actual flight; the data table within the figures offers comparison data on velocity and altitude parameters at the moment of separation and inception of the terminal hypersonic glide phase of flight; as such, they make for interesting comparison to the above predictions.<sup>19</sup> Map 1 shows a plot of the ASSET missions.

The centerline of the ASSET vehicles coincided with that of the Thor and Thor-Delta boosters during launch; at separation--marking "insertion" of the ASSET vehicle in its proper reentry



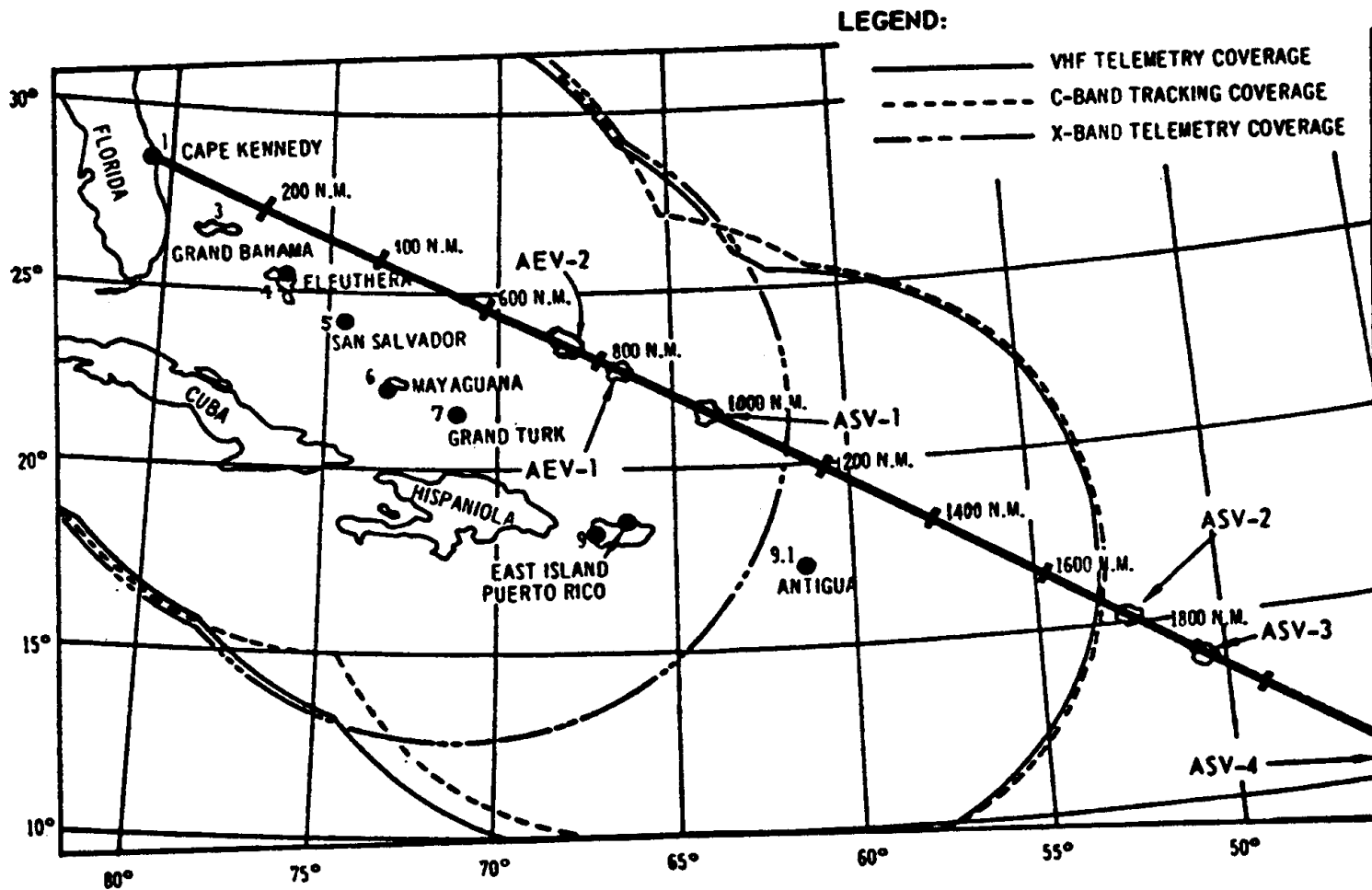
Figure 12

ASSET TRAJECTORIES





ASSET MISSIONS OVER THE EASTERN TEST RANGE



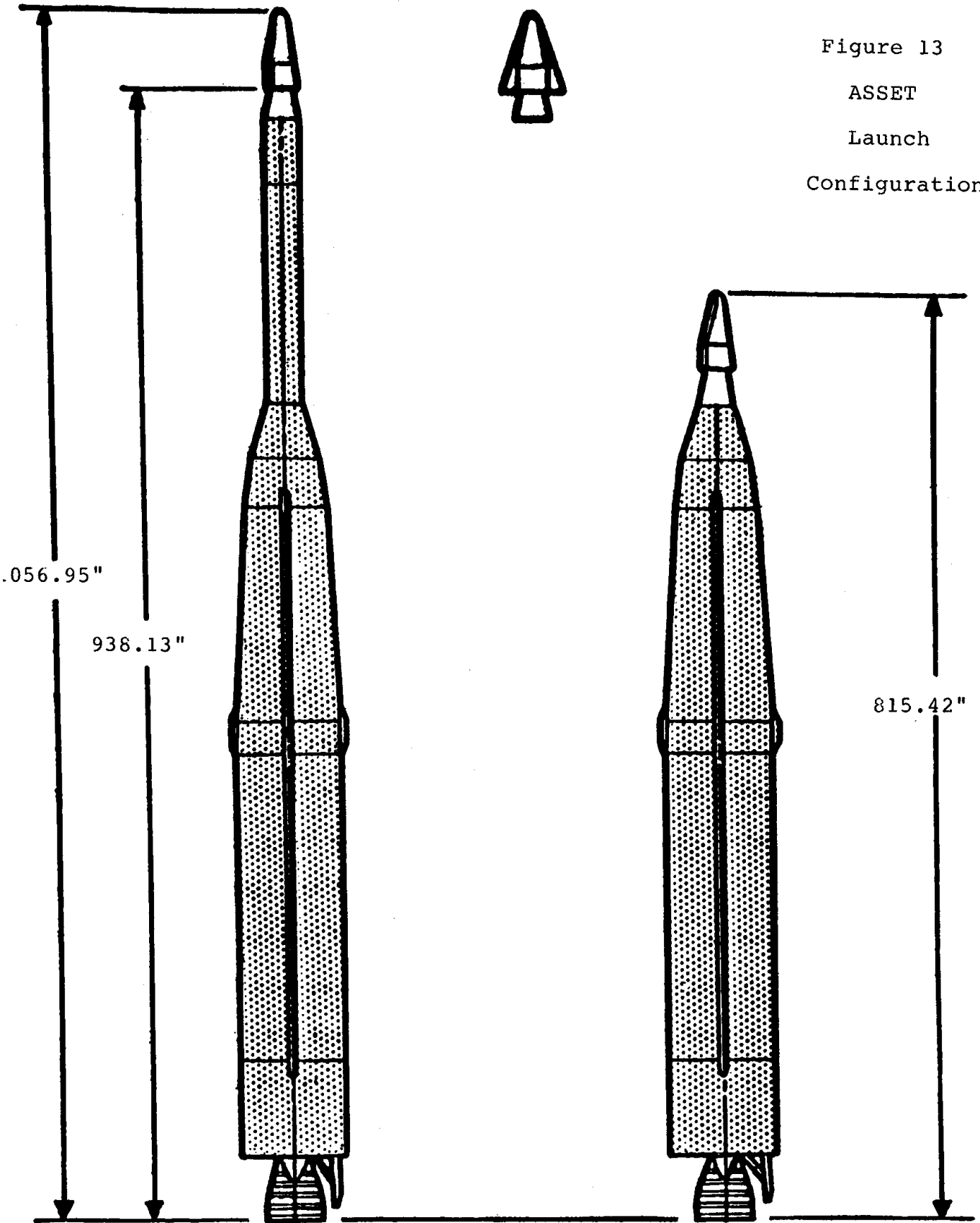
MAP 1

trajectory--the ASSET vehicle would pitch up to its desired trim angle of attack due to inherent aerodynamic stability. The internal guidance and reaction control jet thruster system would control any overshooting tendency (resulting from low aerodynamic damping). The spent booster would drop away, reentering, breaking up, and any remains falling into the sea. ASSET would continue on, hopefully towards recovery hundreds or thousands of nautical miles away. Figure 13 shows a comparison view of the Thor-Delta DSV-2G used for three of the four ASV launches, and the smaller Thor DSV-2F used for both AEV and one ASV launch.<sup>20</sup>

Following completion at the McDonnell plant, ASV-1 arrived at the Cape in the belly of a Douglas C-124A Globemaster II heavy lift transport. Globemasters (called "Old Shakey" by airlift crews) provided heavy lift logistical airlift support, complemented by Douglas C-54 Skymasters and Lockheed C-130 Hercules, transports utilized for operations from the Cape to tracking installations on the various Caribbean islands. The preflight preparations for ASV-1 went smoothly, and in the predawn darkness of September 18, 1963, ASV-1 got underway.

Launch occurred at 4:39:51.996 a.m. EST, the Thor DSV-2F booster rising quickly away from launch pad 17B, trailing a flaring banner from the exhaust of its rocket engine. The trajectory, from boost through insertion and reentry, was virtually perfect. At 328 seconds into the flight, an electrical failure on one channel caused loss of some data and forced data reducers after the flight to have to reconstruct some information, but overall the craft achieved its research objectives. Attenuation of the VHF signal due to ionization did occur, but transmission on X-band overcame blackout problems and playback of the backup onboard tape recorder at the end of the glide provided further backup. After completing reentry, the ASSET vehicle deployed its recovery system. Unfortunately, the Sofar underwater noise bomb failed to detonate, and the Sarah beacon provided only an intermittent

Figure 13  
ASSET  
Launch  
Configuration



THOR-DELTA DSV-2G + ASV

THOR DSV-2F + AEV

signal. ASSET ASV-1 splashed down in the ocean at approximately 64° 50' W. longitude and 22° 05' N. latitude, approximately 6 miles to the left and 60 miles short of the planned impact point of 63° 57' W. longitude and 21° 28' N. latitude. The Sofar failure and the intermittent reception of the Sarah beacon, when coupled with an erroneous bearing flown by a search aircraft, hampered the recovery search and set the stage for a most disappointing conclusion. Two hours and forty minutes after the ASSET splashed down, rescuers sighted the dye marker--but no ASSET. The flotation bag had apparently failed to function properly, carrying ASSET down to the depths of the ocean. "This was a severe loss," Cosenza wrote subsequently, "since no visual material or structural evaluation can be performed on the ASV-1 vehicle components."<sup>21</sup> The failure to recover ASV-1 in no way obscured the success or importance of the flight. For the first time in aerospace history, a lifting reentry spacecraft had successfully returned from space, withstanding the searing environment of hypersonic flight as it plunged back into the atmosphere.

Hoping to prevent a repetition of the recovery debacle of ASV-1, the ASSET team embarked upon redesign and requalification of the troublesome recovery system. This effort, begun in October 1963, met with success the following February when tests of a modified system went well. Hopes were high, then, when ASV-2 launched from the Cape on March 24, 1964. ASV-2 was the first ASSET launched since cancellation of the X-20, and was also the first to use the DSV-2G Thor-Delta booster. It carried experimental Bell "double-wall" test panels, and researchers hoped to "insert" it at 18,000 ft./sec. at an altitude of 195,000 feet. It would assume a 20 degree angle of attack, and then glide for 1800 n.m. before splashing down in the Atlantic. Alas, such was not to be. Following lift-off at 7:15 a.m. EST, the Thor-Delta rose smoothly into the Florida sky. The first stage starved itself and separated, and the second stage, instead of firing, merely "went ballistic." ASSET and the powerless Delta soared



onwards on a doomed trajectory. The ASSET's own timer signaled second stage cutoff - a cutoff that never was - and payload separation, and the ASV-2 departed from the dead stage, cocked over in a 40 degree right bank, 15 degrees more than range safety had previously established as safe for the little craft, lest it stray over inhabited territory. With a 25 degree right bank limit built into the destruct system, ASSET now had the dubious distinction of proving its destruct system could work in flight. Ground monitors, reconciled to failure, watched as radar sweeps picked up the ASSET as a single blip, followed almost immediately by its breaking into multiple radar returns. The potent Aerex explosive had shredded ASV-2 in the upper atmosphere.<sup>22</sup> The disappointment of ASSET's project team can well be imagined. SSD worked to ensure that the Thor-Delta would not experience such an ignominious failure again. Preparations went ahead for the launch of ASV-3. In the early morning of July 22, 1964, project personnel crossed their fingers and tried again. And this time, everything worked.

That morning, ASV-3 rose into the Florida sky from Launch Pad 17B, poised on top of a thundering column of flame. Launched at a 90 degree azimuth, the Thor-Delta-ASSET combination rolled during boost--as Shuttle would subsequently on its own flights--to pick up the proper azimuth, 110 degrees, for insertion in its proper reentry corridor. At 217 seconds after lift-off, at an altitude of 212,050 feet, ASSET separated from its second-stage booster. After separation, the ASSET began a programmed pitch command to assume its proper glide trim angle of attack. The glider pitched up at the rate of 5 degrees per second until it assumed the desired glide angle of 38 degrees "alpha." The reaction control system compensated for any tendency of the vehicle to overshoot or "hunt" around the desired angle, with the pitch jet firing at the rate of six to seven firings per second. Nine seconds after separation, ASSET was finished with the transition stage and firmly in its reentry glide; RCS operation continued

intermittently until  $T + 930$ , when ASSET began its recovery sequence. Throughout the glide, the undamped angle of attack oscillation did not exceed  $\pm 0.3$  degrees. During transition, ASV-3 had experienced a "limit cycle" lateral-directional (i.e.: roll-yaw) oscillation while assuming its proper angle of attack. The RCS controlled this with up to seven firings per second of the roll control jets. During the glide, roll jet operation became less frequent, particularly after ASSET switched to a  $\pm 6.0$  degree roll "deadband" at  $T + 367.1$  seconds. From this point until  $T + 823$  seconds, ASSET no longer required active roll control. Yaw jet operation, on the other hand, occurred frequently; during transition, the yaw jet firing rate was low, and this persisted after transition, the yaw jets firing at a rate of between .05 and .065 cycles per second. After switching to the wide roll "deadband" at  $T + 367.1$  seconds, ASSET assumed a positive sideslip increase of approximately .06 degrees, and to compensate for vehicle attitude, the rate of yaw jet firing increased to 2.5 cycles per second. At  $T + 804.86$  the roll program reverted to a smaller deadband of  $\pm .08$  degrees, and, as a result, the yaw jets went from a 5 pound thrust per firing to a higher 15 pound thrust. The higher thrust effects reduced the number of yaw jet firings per second from 2.5 to about 1 cycle per second, and this rate persisted through the rest of the flight.<sup>23</sup>

Down range, in the recovery zone, rescuers faced four foot seas whipped up by fourteen knot winds from the east-northeast, both well within planned minimums for recovery operations. ASSET's chute and recovery system deployed on schedule and functioned as advertised; ASV-3 splashed down, hissing in the cold ocean, its Sofar bomb setting off an audible signal, and its Sarah beacon broadcasting to the world where the little delta rested, suspended on a short tether underwater from its flotation bag. However, instead of resting in swells amid the recovery fleet, ASSET was eighty miles uprange and five miles off-track, thanks to

the persistent five percent range error afflicting its actual versus planned performance. Five minutes after splashdown, an orbiting recovery aircraft spotted ASSET's dye marker and flotation bag, sending recovery forces on their way. Para-rescuemen dropped into the sea and attached an auxiliary flotation collar to the ASSET twenty minutes after splashdown. The flotation bags functioned perfectly. ASSET drifted slightly in the face of the seas in a westerly direction, and 12 1/2 hours after it entered the water, the recovery vessel Coastal Crusader came alongside and hoisted ASV-3 aboard. Technicians secured it to a special transportation pallet, purged its Aerex explosive and H<sub>2</sub>O<sub>2</sub> systems with fresh water for four hours, and set course for Bridgetown, Barbados. There, a waiting truck took it to a Lockheed C-130 Hercules transport that carried it to Patrick Air Force Base. A Douglas C-54 ferried it back to the McDonnell plant at St. Louis--singed, scorched, but otherwise in remarkable condition.<sup>24</sup>

That same month, the Air Force had transferred data reduction responsibilities to McDonnell, and company technicians now began a laborious process that culminated in the issuance of a technical report on the flight the following March. Disassembly of the spacecraft revealed that, overall, it was in excellent condition. Water damage--particularly to insulation blankets and beryllium heat sinks--caused some problems but not so serious that McDonnell could not have refurbished and reflown the vehicle, if necessary. The onboard tape recorder experienced a water "short" that erased a portion of the flight record, but, fortunately, X-band transmission overcame anticipated loss-of-signal problems during ionization, leaving a virtually complete telemetry record. Data reduction indicated that two nose pressures, one upper surface wing pressure, and three lower panel temperatures were invalid or questionable; aside from this, the data reduction system had performed satisfactorily. Hypersonic reentry conditions resulted in "significant deterioration" of the left and right-hand forward columbium leading edges by erosion, and, as a result of ASV-3,

McDonnell redesigned this section of structure for future ASV and AEV vehicles. The Boeing and Bell test panels survived the flight environment without damage, though both showed discoloration from salt water exposure. Overall, while ASSET showed some signs of coating deterioration, the vehicle had survived without incurring significant structural damage, save for the aforementioned columbium leading edge segments. Researchers determined that ASSET's performance did not degrade due to Mach number, Reynolds number, or "real gas" effects, and overall, ground facilities had well predicted its lift and drag characteristics. (During the flight, ASV-3's L/D had varied from approximately .85 at Mach 15.5 to 1.0 at Mach 2.5.) However, the five percent range error, first encountered on ASV-1 (and a hallmark of ASSET flight operations right through ASV-4, AEV-1 and AEV-2), showed up again, attributable to a higher trim angle which reduced L/D, poor ground facility prediction (flights showed an increase in trim angle with increasing Mach number, whereas wind tunnels predicted the reverse), and the fixed geometry of the ASSET spacecraft itself. The guidance system had performed superbly. Aerodynamic data (primarily pressure and force coefficients) and structural deflections and temperatures were in general agreement with predictions, and the various metals, coating, fasteners, and insulations deemed necessary for lifting reentry vehicles, had proven themselves more than adequate. Overall, McDonnell concluded, ASV-3 had been a complete success. FDL agreed. ASV-3 went on exhibit, a tribute to the team that conceived and developed it, and eventually entered the collections of the Air Force Museum, where it is on proud display today, a genuine pioneer of the hypersonic revolution.<sup>25</sup>

AEV-1 followed ASV-3 on October 27, 1964, launched by a single-stage DSV-2F Thor booster. With the flight experience of ASV-1 and ASV-3 behind them, planners now were better able to anticipate ASSET's actual range performance, and, as a result, AEV-1 plunged into the ocean--unlike the ASV's, the AEV's lacked a

recovery system, the space for the system being taken up by additional experiments and supporting equipment--a mere four miles from its predicted impact point, after a journey of 850 n.m. AEV-2 followed on December 8, 1964, but unlike the fully successful flight of AEV-1, failure of the flutter test panel during the gliding return marred the research accomplishments of this particular mission. Nevertheless, postflight examination of the data from AEV-1 and AEV-2 caused researchers to conclude that both missions had fully justified their expectations. The AEV vehicles carried the flutter experiment and the aerodynamic flap experiment. Data indicated that prediction techniques were adequate for predicting flutter velocities for hypersonic vehicles, but confirmed that thermal effects greatly influenced stiffness requirements. AEV-1 generated only one flutter data point (at Mach 11.88) and then 18 other points from Mach 3.89 down to Mach 1. AEV-2 furnished useful information until it failed at about Mach 10 (perhaps significantly, the flutter panel on AEV-2 had reduced stiffness, based on information from AEV-1 that indicated the planned panel on AEV-2 would probably be too stiff to obtain flutter throughout its flight. Technicians etched off part of the protective coating of the AEV-2 panel recognizing that this would reduce its oxidation protection but accepting this as a necessary trade-off to get the hypersonic flutter data). Data from the unsteady flap aerodynamics experiment indicated that unsteady effects were very small and indeed of negligible magnitude, despite instrumentation deficiencies that limited the quality of data derived from this experiment. Newtonian theory predicted higher oscillatory pressure coefficients than ASSET actually encountered, but predictive shock expansion theory agreed very well with the data that ASSET returned. Overall, the AEV portion of ASSET had concluded on a positive, upbeat note. What remained was the final flight of the program, ASV-4.<sup>26</sup>

ASV-4 had completed systems test checkout procedures at McDonnell at the end of November 1964, and, following missile systems test, McDonnell shipped it to the Cape aboard a C-124 on January 4, 1965. Technicians completed final checkout procedures and high temperature painting following mating of the ASSET to its Thor-Delta booster on February 13. On February 23, 1965, right on the flight schedule established ten months previously, ASV-4 launched from Pad 17B at the Cape amid cloud and local rain. At 202,000 feet and a velocity of 19,400 feet per second, ASSET separated from the spent Delta second stage, pitched up to approximately a 25 degree angle of attack (5 degrees higher than planned) and settled into the long hypersonic glide earthwards. During the glide, higher than predicted angle of attack during the early portions of the flight gave ASSET a phugoid oscillation around the planned trajectory track (see Figure 12 for profile information) as it alternately dipped and rose about the desired track. ASV-4's planned flight--a planned 2394 mile journey--took it approximately 450 miles beyond available radar tracking; in any case, the higher "alpha" resulted in a substantial lessening of range, so that ASV-4 impacted 94 miles up-range from the planned recovery area after completing a roughly 2300 mile flight. Data acquisition systems functioned to near perfection, all planned measurements being obtained with two minor exceptions: 29 rather than 33 surface pressures obtained, and 39 instead of 40 surface temperatures obtained. X-band and tape play back functioned perfectly, data being acquired by ground stations, the recovery ships Twin Falls, Coastal Crusader, and Timberhitch, and Silver 1, 2, and 3, range instrumentation aircraft. The mercury ballast transfer system functioned as expected in permitting changes in c.g. and, hence, changes in angle of attack, notably at T + 880 when one such shift at Mach 10 to extend the trajectory resulted in a pitch-up to an L/D of about 1.4, the highest encountered during the ASSET program. (Throughout the flight, ASV-4's L/D ratio averaged approximately 1.2, varying above or below depending on

flight conditions and vehicle angle of attack at any particular point along the trajectory). Figure 14 offers a table of ASSET ASV-4 velocity and altitude values according to time plotted by McDonnell on the basis of "smoothing" the trajectory data for more reliable analysis. Unfortunately, when the parachute recovery system deployed, the dis-reefing process went awry, inducing excessive loads which ripped the recovery chute from the spacecraft. ASV-4 fell into the sea, slipping beneath the waves to a watery grave.<sup>27</sup>

Undeniably disappointed not to have the chance to examine ASV-4's structure, researchers nevertheless recognized that the last flight had been a complete success, and a fitting ending to the ASSET program. McDonnell's flight test report on ASV-4 concluded (in part) that:<sup>28</sup>

The flight of ASSET ASV-4 . . . was highly successful, yielding valuable technical inflight information from flight experiments and surface data measurements, although the vehicle was not recovered. ASV-4 was flown to the highest speed ( $V = 19,400$  fps, Mach No. = 18.4) attained in the ASSET program. This was considerably higher than the 18,000 fps design speed. ASV-4 flew 2300 n.m. compared with the 1390 n.m. attained by ASV-3. ASV-4 experienced the highest temperatures and highest L/D of the program and provided the low angle-of-attack data planned . . .

Data received during the flight was essentially complete and represented the highest quality data of the ASSET program.

Aerodynamic data received during the flight was in general good agreement with predictions although the angle of attack was approximately 5 degrees higher than predictions. The high angle-of-attack resulted in the impact point being 3.75% short of prediction.

Data reduction and analysis from the ASSET program continued into mid-1966. From the inception of the program through issuance of the final reports took approximately eighty months. ASSET generated an important series of conclusions and recommendations. Overall, the Flight Dynamics Laboratory concluded that:<sup>29</sup>





Figure 14

## ASV-4 SMOOTHED TRAJECTORY

<u>TIME (SEC.)</u>	<u>VELOCITY (FPS)</u>	<u>ALTITUDE (FT.)</u>	<u>TIME (SEC.)</u>	<u>VELOCITY (FPS)</u>	<u>ALTITUDE (FT.)</u>
0					
6	70	335	370	17,925	202,745
10	125	715	380	17,830	202,810
20	275	2,670	390	17,725	202,425
30	465	6,280	400	17,640	201,865
40	700	11,850	410	17,575	200,625
50	1,000	19,630	420	17,470	199,150
60	1,360	29,760	430	17,370	197,820
70	1,800	42,060	440	17,270	196,005
80	2,370	56,470	450	17,165	194,135
90	3,055	73,215	460	17,050	192,315
100	3,884	91,475	470	16,925	190,600
110	4,895	109,954	480	16,800	188,180
120	6,110	127,820	490	16,655	186,450
130	7,565	144,040	500	16,495	184,790
140	9,360	157,600	510	16,345	183,210
150	11,790	168,155	520	16,190	182,220
160	14,410	176,780	530	16,035	181,555
170	15,355	183,875	540	15,875	181,040
180	15,710	189,395	550	15,730	180,835
190	16,190	193,590	560	15,580	180,715
200	16,690	196,845	570	15,435	180,705
210	17,235	199,325	580	15,295	180,770
220	17,820	201,010	590	15,160	180,720
230	18,465	201,765	600	15,020	180,420
240	19,140	201,410	610	14,890	180,155
* 243.88	19,400	200,980	620	14,760	179,730
250	19,390	200,065	630	14,620	179,135
260	19,245	198,545	640	14,490	178,365
270	19,095	197,590	650	14,360	177,165
280	18,950	197,215	660	14,215	176,340
290	18,810	197,285	670	14,070	175,155
300	18,670	197,740	680	13,920	173,380
310	18,545	198,440	690	13,780	172,370
320	18,425	199,420	700	13,645	170,795
330	18,315	200,370	710	13,480	169,000
340	18,210	201,340	720	13,320	167,400
350	18,105	202,050	730	13,150	165,900
360	18,010	202,585	740	12,980	164,600

\*payload separation

Figure 14 (concluded)

<u>TIME (SEC.)</u>	<u>VELOCITY (FPS)</u>	<u>ALTITUDE (FT.)</u>	<u>TIME (SEC.)</u>	<u>VELOCITY (FPS)</u>	<u>ALTITUDE (FT.)</u>
750	12,820	163,600	1,025	7,310	149,200
760	12,660	162,600	1,035	7,080	144,400
770	12,490	161,700	1,045	6,830	139,800
780	12,320	160,900	1,055	6,540	135,600
790	12,150	160,200	1,065	6,230	132,000
800	11,980	159,500	1,075	5,920	129,200
810	11,800	158,900	1,085	5,610	127,100
820	11,640	158,200	1,095	5,330	125,600
830	11,460	157,700	1,105	5,080	124,300
840	11,280	157,000	1,115	4,860	123,000
850	11,110	156,300	1,125	4,650	121,500
860	10,930	155,500	1,135	4,450	119,800
870	10,750	154,600	1,145	4,260	117,700
** 875	10,650	154,000	1,155	4,070	115,300
885	10,430	153,600	1,165	3,880	112,500
895	10,170	153,800	1,175	3,690	109,600
905	9,850	154,800	1,185	3,490	106,600
915	9,520	156,600	1,195	3,280	103,500
925	9,220	158,900	1,205	3,070	100,500
935	8,960	161,200	1,215	2,850	97,700
945	8,740	163,200	1,225	2,630	95,000
955	8,540	164,500	1,235	2,420	92,400
965	8,360	165,000	1,245	2,220	89,800
975	8,190	164,600	1,255	2,020	87,100
985	8,030	163,200	1,265	1,840	84,300
995	7,870	160,800	1,275	1,670	81,300
1,005	7,700	157,600	1,285	1,510	78,000
1,015	7,520	153,600			

\*\* Trajectory Extension Begins at 875 seconds

Total Flight Range - 2300 Nautical Miles

1. ASSET's quality of aerodynamic and thermodynamic data justified its use as a standard for evaluation and comparison with present and planned future ground research facilities.

2. The ASSET project had provided a significant overall increase in confidence regarding aerodynamic and thermodynamic theories and ground test techniques.

3. Based on the ASSET experience, aerodynamic prediction techniques and the use of on-board air data sensors on future unmanned vehicles would permit gaps in ground radar coverage to be tolerated in the future.

4. Use of an on-board data system would obviate the necessity of using meteorological sounding rockets for upper atmospheric data acquisition, as had been done in supporting ASSET flights.

5. ASSET conclusively demonstrated that post-flight data reduction should be the responsibility of the organization having the most detailed technical knowledge of the program.

6. ASSET furnished important information and experience in comprehending the nature of communications blackout phenomena during reentry, but also pointed to the necessity for additional flight data for a fuller understanding of blackout phenomena.

7. ASSET demonstrated that a unmanned lifting reentry flight test program needs a minimum of four months between flights for optimum vehicle preparation and effectiveness.

8. ASSET convincingly justified continued use of unmanned vehicles for free flight lifting reentry research.

ASSET undoubtedly greatly increased the available technology base for lifting reentry vehicles. At a comprehensive ASSET wrap-up technology symposium held at the Carillon Hotel in Miami Beach, Florida, on December 14-16, 1965, Flight Dynamics Laboratory

briefers listed no less than twelve direct technology contributions by the ASSET development effort to the technology base for future manned reentry systems. These included:<sup>30</sup>

- \*Demonstration of a radiative hot structure
- \*Practical fabrication of refractory metals
- \*Demonstration of the capabilities of oxidation protection coatings
- \*Development of fabrication processes
- \*Understanding of prediction methods and the hypersonic flight environment
- \*Fastener capabilities
- \*Coating processes
- \*Design experience for communication and tracking systems
- \*Development of high-temperature instrumentation
- \*Understanding of the performance of communication systems during hypersonic reentry
- \*Design of a reaction control system for lifting reentry vehicles

As FDL technical staff members noted, ASSET had great application to future systems because it demonstrated the application of refractory materials on hypersonic vehicles; proved that the United States possessed a theoretical base and facility network capable of supporting the aerodynamic and thermodynamic design of such craft; and improved confidence in ground testing and theoretical predictive methods, particularly as involved preventing dynamic and aeroelastic problems on hypersonic vehicle designs. All of these paled, however, before the single great accomplishment that guaranteed ASSET's place in the history of hypersonic flight: ASSET offered the first practical experience the aerospace community had with an actual lifting reentry vehicle returning from space at near-orbital velocities. Truly it was the pathfinder of lifting reentry.

At the time ASSET concluded, the PRIME project--for Precision Recovery Including Maneuvering Entry--was well underway. ASSET's developers had envisioned two possible "growth" versions of the basic ASV vehicle, one having body flaps for drag and directional control located on the sides of the aft fuselage, and the second having such flaps moved to the back of the craft and complemented by elevon surfaces located on the trailing edges of the wings. Such plans died, however, as the lifting body PRIME spacecraft took shape at the Martin plant. PRIME constituted the next step, and so ASSET wound down, the last reports being written, until finally all that was left was the rich legacy of a program well done, and a historical spacecraft on exhibit at the Air Force Museum.

## NOTES

1. Cosenza interview.
2. Ibid.
3. Ibid.; zirconia test data from a briefing slide in the possession of Mr. Cosenza; see also LaFavor, p. 15-4.
4. Cosenza interview.
5. Frank L. Wattendorf, A Chronology of the Background and Early History of the Arnold Engineering Development Center, 1938-1949 (Tullahoma, TN: AEDC, 1986) pp. 8-9, 13, 15, 18; Donald D. Baals and William R. Corliss, Wind Tunnels of NASA, SP-440 (Washington, D.C.: NASA, 1981), pp. 56-57.
6. ASSET Final Briefing, "Hypersonic Aerodynamics/Pressures" and "Hypersonic Aerodynamics/Forces, Stability, and Performance" tables.
7. ASSET Tech Plan, Figure 4-3, "Test Schedule."
8. Ibid., pp. 48-70.
9. Ibid., p. 72; Blome et. al., p. 3.
10. Blome, et. al., p. 22; ASSET Tech Plan, p. 75.
11. Blome, et. al., pp. 10-15, 22, 27-39.
12. Ibid., p. 24.
13. Charles J. Cosenza, "ASSET: A Hypersonic Glide Reentry Test Program," paper presented to the 1964 Annual Fall Meeting of the Ceramic-Metal Systems Division, American Ceramic Society. I wish to thank Mr. Cosenza for making a copy of this paper available for my research.
14. Blome, et. al., pp. 41-89.
15. LaFavor, pp. 15-2 & 15-3.
16. Blome, et. al., pp. 69-84.
17. Ibid., pp. 93-100.
18. Cosenza, "ASSET: A Hypersonic Glide Reentry Test Program," n.p.

19. Adapted from the ASSET Final Briefing, "ASSET Trajectories" table. Prediction data is from the ASSET Tech Plan, p. 36.
20. ASSET Tech Plan, pp. 87-90.
21. Cosenza, "ASSET: A Hypersonic Glide Reentry Test Program," n.p.
22. Ibid.
23. McDonnell, ASV-3 Flight Test Report, pp. 1, 27-30, 145-146.
24. Ibid., pp. 106-107, 170.
25. Ibid., pp. 106-108, 173.
26. McDonnell, ASSET ASV-4 Flight Test Report, B707 (65FD-938), (St. Louis: McDonnell, rev. ed. June 25, 1965), pp. ii-iii; Shirk, Figures 7-16 and related texts; ASSET Final Briefing, "Results" charts.
27. McDonnell, ASV-4 Flight Test Report, pp. iii, 1, 4, 7, 29, 121-122, 127, 145-147.
28. Ibid., p. 156.
29. Paraphrased and elaborated from a truncated and abbreviated listing in the ASSET Final Briefing, "Conclusions and Recommendations" charts.
30. Ibid., "ASSET Technology Contributions to the AMR Program" charts.





CASE V

PROJECT PRIME: HYPERSONIC REENTRY FROM SPACE

by

John L. Vitelli

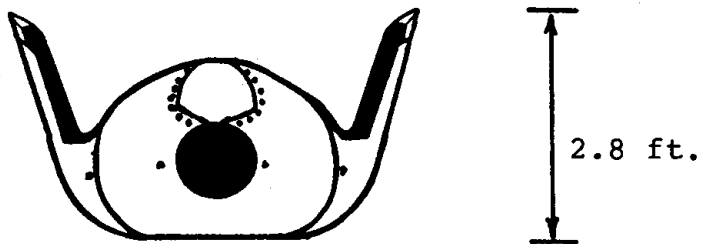
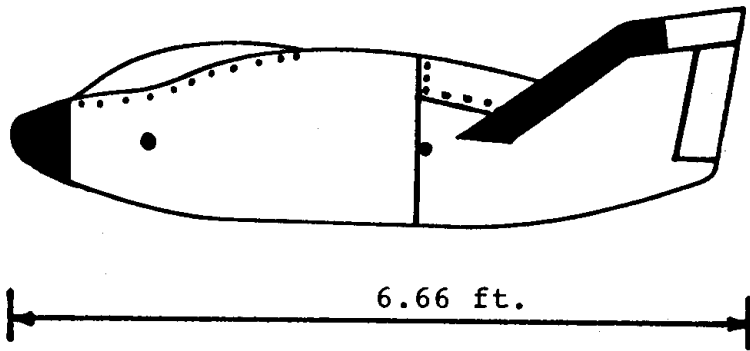
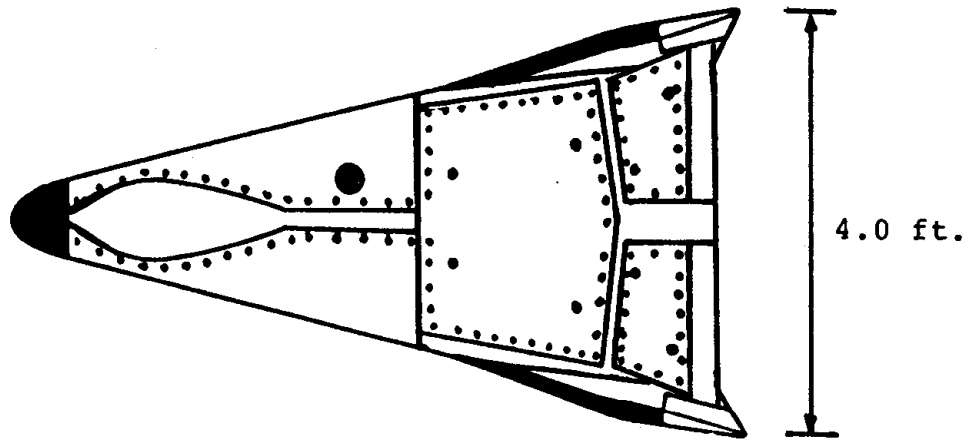
Richard P. Hallion

## EDITOR'S INTRODUCTION

The ASSET program furnished useful information on the aerothermodynamics and aeroelastic characteristics of a representative winged shaped reentering the upper atmosphere at velocities comparable to those of an IRBM. In 1966 and 1967, however, the Air Force flew three research flights of a totally different kind of hypersonic vehicle: an ablative-cooled lifting body shape termed the SV-5D (though the SV-5D has been referred to as the X-23, there is no evidence from contemporary documents and reports that confirm the X-23 designation, leading to the conclusion that the designation "X-23," if ever, in fact, applied, was applied well after the conclusion of the SV-5 program). Unlike the ASSET, which had sacrificed an optimum aerodynamic configuration in favor of large internal payload volume, the SV-5D, known as PRIME (for Precision Recovery Including Maneuvering Entry), emphasized aerodynamics with a carefully derived external shape. Again, unlike the structures and heating-oriented ASSET, PRIME explored the problems of maneuvering entry, including pronounced cross-range maneuvers (up to 710 miles) off the ballistic track. In addition, PRIME involved development of not only a technology demonstrator, but a possible operational data-return SV-5D system for national security missions (though the Air Force did not proceed with this option). It also generated a planned low-speed piloted demonstrator, the SV-5P, known initially as PILOT (for Piloted Lowspeed Tests) and ultimately as the X-24A. (This latter program is discussed in a subsequent case study.)

The PRIME/SV-5D spacecraft (Figure 1) was a somewhat portly design developed by the Martin Company and launched from an Atlas booster. Unlike the radiative-cooled ASSET which used great

Figure 1



MARTIN SV-5D HYPERSONIC RESEARCH LIFTING BODY

amounts of exotic materials, PRIME relied upon titanium as its principal structural element, as well as aluminum, beryllium, and stainless steel. The thermal protection system consisted of Martin-developed silicon ablative heat shielding in a honeycomb-fiber matrix to minimize flowing of charred material. Areas of particularly strong heating (such as the maneuvering flaps on the vehicle's underside and nose cap) utilized a carbon-phenolic ablator. Like ASSET, PRIME had its share of recovery headaches, and of the three vehicles flown, recovery forces only managed to retrieve one of them, by mid-air snatch using a modified Lockheed JC-130 Hercules.

The story of PRIME is more expansive than that of ASSET, because unlike ASSET, PRIME involved broader issues necessitating advice and decision-making from within the highest councils of the civilian Pentagon community. This resulted in a fitful series of starts and near-stops that make for interesting reading to students of defense systems acquisition management. PRIME ultimately met with the same unqualified success as had its predecessor ASSET, in part because both programs were very ably managed by their military and industrial managers, and because the managerial relationship between the Air Force, the reentry vehicle contractor, and the booster contractor worked exceedingly well. It is a measure of PRIME's success that the planned fourth flight was canceled as unnecessary in light of the crowning success that had attended the preceding three missions. The PRIME spacecraft is today on exhibit at the Air Force Museum, Wright-Patterson AFB, Dayton, Ohio, like ASSET, fittingly memorialized as a pioneer of the hypersonic era.

This case study was originally prepared in October 1967 by Capt. John L. Vitelli, USAF, a mathematician assigned to the PRIME project office. It has been extensively edited, reorganized, and rewritten to make it a more useful, contemporary, and readable document. Like ASSET, PRIME's history has much to offer the contemporary decision-maker involved in studying the management and structuring of development programs for unmanned hypersonic technology demonstrators.

## CHAPTER I

### PRIME AND START: FROM CONCEPT TO GO-AHEAD

It is difficult to establish the exact moment when the SV-5 (for Space Vehicle 5) lifting body configuration emerged. In early 1957, Dr. Alfred Eggers of the National Advisory Committee for Aeronautics' Ames Aeronautical Laboratory (later the NASA Ames Research Center) first conceived a lifting body called the M-1 (Figure 2). The M-1 was a 13 degree blunt half-cone configuration, flown flat side up. It could maneuver during reentry utilizing flaps attached to the body and trailing aft. This configuration offered hypersonic lift-to-drag (L/D) ratio of about 0.5 and a reentry cross-range of up to 170 miles from the orbit plane. The M-1 had virtually no subsonic L/D and could not land horizontally.

Dr. Eggers and his associates at Ames stirred a small but growing nationwide interest in the potential of lifting body reentry vehicles in future space operations. By 1960, Project Mercury was already in the hardware stage and many optimistic aerodynamicists looked beyond even the more exotic Gemini spacecraft then being considered, believing a better flying machine could be developed to operate in space than even this second-generation space program. The lifting body concept offered a possible solution.

At this time, several respected aerospace corporations began company funded efforts in an attempt to learn more about lifting bodies and to possibly improve on the design and performance of this generic class of vehicle. One such example was the Martin

Company of Baltimore, Maryland. At the beginning of the 1960s the Martin Company - which had lost to Boeing on the X-20 program - was studying reentry vehicles that offered potential advancement of the SAMOS operational concept.\* NASA contracted with Martin at this time to study various semiballistic vehicles including Mercury-type capsules with offset center of gravity as part of the Apollo study effort. The M-1 shape was one of many examined in this study.<sup>1</sup>

On August 8, 1960 the Air Material Command's (AMC) Ballistic Missiles Center sent out a request for proposal (RFP) asking for proposals on both ballistic and maneuverable lifting body reentry vehicles for operational SAMOS missions. The Martin Company responded and submitted their response on October 12, 1960. On November 14, 1960 the Air Force awarded letter contract AFO4(695)-726 to the Martin Company for a company effort termed "Project 726." Project 726, based essentially on Martin's lifting body reentry vehicle proposal, included full-scale flight testing, though not provision for operational missions. Camera simulation would substitute for the original planned camera installation. The Project 726 reentry vehicle was to use the Eggers' M-1 configuration with a reference diameter of 102 inches and an ablative heat shield. Exospheric (space) control of the vehicle would be maintained by cold gas jets; when the atmosphere began to affect the vehicle's motion at the inception of reentry, six aft-trailing flaps would stabilize and maneuver the reentry vehicle. The design would incorporate space for data packages of various shapes. The original planned booster was an Atlas-Agena B for orbit injection and orbital stabilization, but for the Project 726 demonstrator, a Thor booster would be utilized.

Over the next 12 months the government directed several technical and cost changes to Project 726, including, in

---

\*As originally planned, the SAMOS (Satellite and Missile Observation System) included use of recoverable data capsules.

December 1960, the decision to eliminate Thor as the booster and limit the flight test program to five full-scale vehicles to be placed in orbit from the Atlantic Missile Range aboard Titan IIs. In February 1961, program expenditures were limited to \$5 million for fiscal year (FY) 1961 and a portion of the research and development plan was eliminated. Hence, the first flight was delayed about three months to mid-1962. Later, in February 1961, the government further limited, for planning purposes, program expenditures to \$14 million for the first half of fiscal year 1962 and \$1.5 million per month for the remaining calendar year. The first flight now slipped to January 1963. Then, in early March 1961, the government eliminated orbital flights and camera simulation. The major objective now shifted to proving the feasibility of a maneuverable lifting body reentry vehicle. Later that same month, the government further limited expenditures and directed the program be conducted in two phases. Phase I, extending through March 1962, consisted of a design study, development tests, and a system preliminary design. Phase II, starting in late 1962, consisted of the design, fabrication and flight test of five maneuverable lifting body reentry vehicles. The first launch was scheduled for November 1963. In June 1961, Phase I was extended through June 1962 and Phase II was rescheduled to begin in January 1962. In July 1961, the government directed the demonstration of an operational guidance system in Phase II. In August 1961 the designation changed from Project 726 to Program 202.<sup>2</sup>

In September 1961, Program 202 was reasonably well defined and its objectives and mission profile were carefully outlined. The Martin Program Plan stated the purpose of the 202 program to be development and testing of a maneuverable payload recovery capability, described as a demonstration of the ability to maneuver and guide a "reentry satellite" to impact at a preassigned small water area. The selected vehicle, the M-1 developed by

NASA's Ames Research Center, would begin its descent from a flight altitude comparable to an operational orbit and be recovered after impact. Such a demonstration, stated Martin, would ". . . provide an adequate basis for future design of operational reentry vehicles." Moreover, the successful completion of the program would ". . . furnish growth and flexibility in recovery of data payloads with satisfactory reliability at predetermined sites within the continental United States."<sup>3</sup>

The program required extensive preliminary study. For example, one study defined the orbital environment; additional thorough research would precede selection of a vehicle configuration having the ". . . optimum expectation of accomplishing the test mission after exposure to the anticipated orbital environment." It was also necessary to examine the orbital mission requirements ". . . to evaluate the desirability of altering or increasing the performance demands on subsystems in the test vehicle." The vehicle's terminal guidance system would perform all reentry maneuvers to impact within a small area. The Martin plan also pointed out the necessity for establishing overall system design criteria, a materials testing and wind tunnel testing program, and extensive aerodynamic performance analysis to further substantiate the capability of demonstrating desired system performance.<sup>4</sup>

At this early stage, major program fluctuations were inevitable. In January 1962, Program 292 was completely reoriented and designated Program 698AN. The Air Force directed Martin to begin studies and tests to select a more advanced lifting reentry body configuration with greater "call-down" frequency capability than the M-1 provided. The advanced shape would accomplish this through greater cross-range maneuverability. In mid-1962, the 698AN program shifted again, now aimed at developing a complete orbital system compatible with and able to fully utilize the payload capability of a Titan IIIC booster launched in



polar orbit from Vandenberg Air Force Base on the California coast north of Santa Barbara, near Lompoc. A 9000 pound payload was to be orbited; a payload of up to 2000 pounds could subsequently be recovered. A special midsection would orbit with the reentry vehicle for a mission of up to five days; upon completion of the orbital phase, this midsection, used for vehicle stabilization and orbit maintenance, would separate from the reentry vehicle. Each would "deorbit" separately. Terminal guidance would direct the lifting body to Wendoover Air Force Base in Massachusetts where it would complete a pilotless conventional tangential landing. The reentry vehicle's inertial guidance system would guide it to a "window" of 50 miles about 300 miles from the landing site. At Mach 0.8 and 7500 feet, the reentry vehicle would approach the landing area, then flare before touchdown at a speed of 260 knots and a descent rate of 23 feet/second. The craft would maintain a constant angle of attack until it slowed to about 158 knots and reached a descent rate of 14 feet per second. At this point the vehicle would lower its landing skids and land. If all else failed, a parachute recovery system would save it in an emergency.<sup>5</sup>

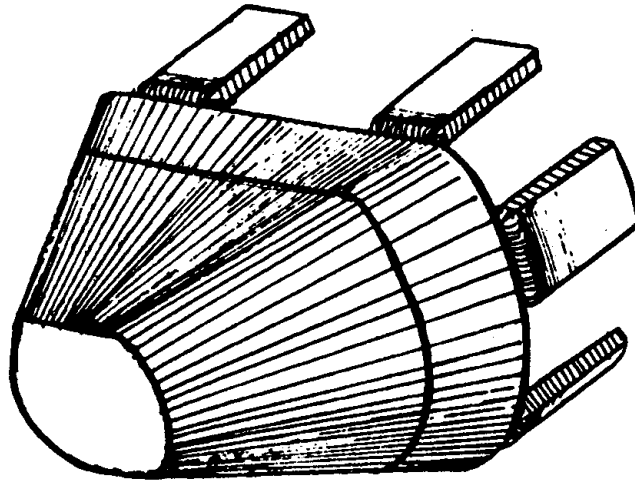
During this time period, three lifting body shapes were receiving consideration by the Martin Company. The A-3 (Figure 3) configuration was developed by the Aerospace Corporation of Los Angeles and utilized the flat bottom concept with two outboard dorsal fins.\* It was fairly stubby and had poor subsonic/transonic performance. In fact, at that time, there were no known lifting body configurations with a realistic location of the center of gravity which were capable of transonic and subsonic controllable flight. As backup to the A-3 configuration, Martin, in April 1962, suggested serious pursuit of configurations then

---

\*Aerospace Corporation was a non-profit corporation established by the Air Force to perform systems engineering and technical direction of Air Force space programs and conduct related research activities.

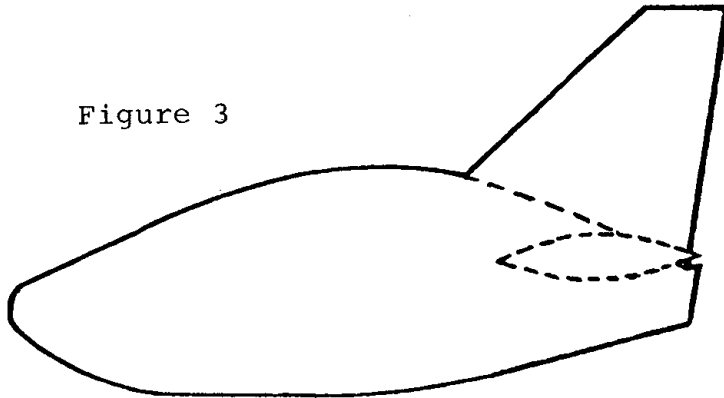


Figure 2



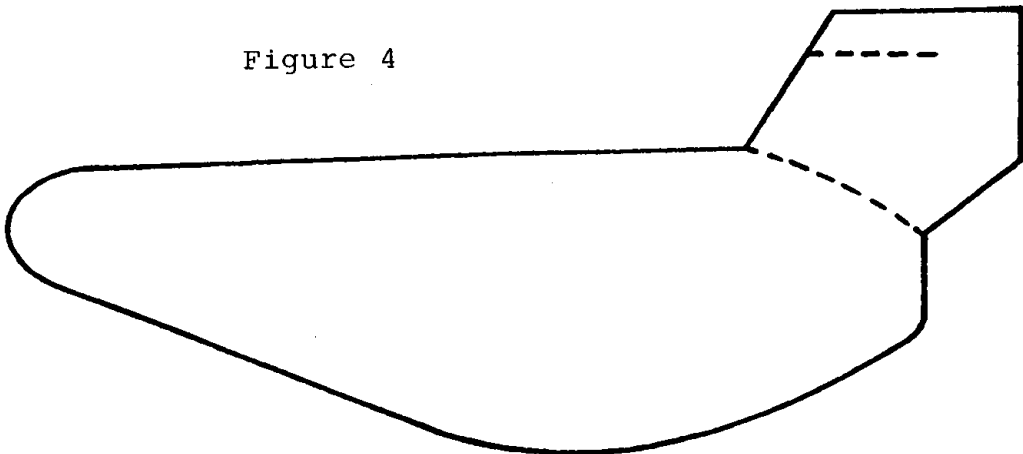
THE M-1 LIFTING BODY

Figure 3



THE AEROSPACE A-3

Figure 4



THE MODIFIED M-2b

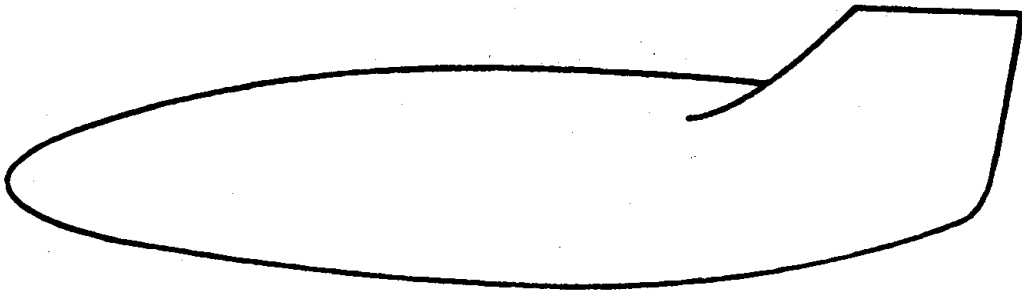
termed the Modified M-2b (Figure 4) and the A3-4 (Figure 5). Martin felt that initial design emphasis for lifting body configurations should be given to the transonic and subsonic performance characteristics since these are the most difficult to achieve. This suggested backup effort would consider landing configurations, provide subsonic and transonic flight characteristics and then address the hypersonic performance requirements, in that order.<sup>6</sup> The "stock" M-2b (Figure 6) did not follow this progression and hence did not qualify as a backup without modification. The M-2b was an outgrowth of the M-2, a lifting body generated simply from modifying the geometry of a half-cone. By adding an aft "boattail," vertical fins, and several control devices to the M-2, engineers hoped to obtain favorable subsonic performance characteristics; wind tunnel tests, however, proved otherwise.<sup>7</sup>

The guidelines set forth for the 698AN program backup, as set forth by the Martin Company, were:<sup>8</sup>

1. A hypersonic lift-drag ratio above 1.1, but less than 1.5.
2. A subsonic lift-drag ratio above 3.5, and in fact, the larger the better, with no upper limit.
3. Adequate longitudinal and directional stability through the full speed range between Mach 0.25 and Mach 25.0, far aft c.g. location (60% of body length desired).
4. Good volumetric efficiency so that the ratio of total wetted area to the  $2/3$  power of the enclosed body volume would not exceed 10.
5. Controllability through the full flight speed range.

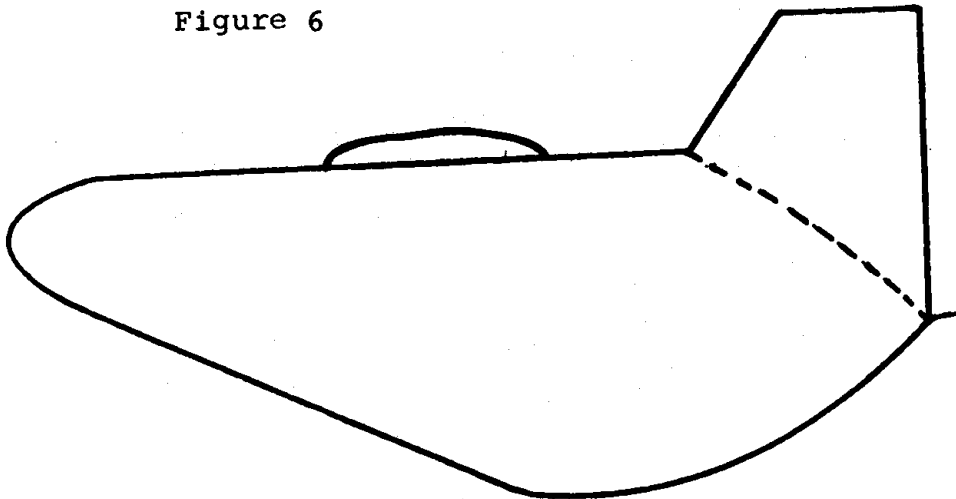
The M-2 required major changes to meet these guidelines, including increase the planform sweep angle from 13 to 15 degrees

Figure 5



THE A3-4

Figure 6



THE M-2b

and sizing the vehicle to accommodate 250 cubic feet of payload volume. The maximum subsonic lift-drag ratio attainable on a lifting body, Martin argued, was a function of both the boattail angle and the base area of the body. If the boattail angle was minimized, a large base area resulted with a correspondingly large base drag contribution. This degraded the lift-drag ratio. If, on the other hand, the boattail angle was maximized, as in the case of the A-3, to result in as small a base area as possible, premature flow separation over these camber lines resulted, and again the lift-drag ratio was degraded. In order to preclude this effect, the original M-2b boattail base area configuration was retained. Hence the Modified M-2b was conceived.<sup>9</sup>

At this same time, in March 1962, while Martin was busy running parametric wind tunnel tests on the A-3 and discrete variations based upon it as well as on other specified shapes, Hans Multhopp of Martin, working separately, decided an alternative to this parametric approach might be possible. Multhopp was, at that time, well known for his work in the field of aerodynamics. A former Nazi engineer, during World War II he had worked for the Focke-Wulf Flugzeugbau in Bremen, Germany, heading the Aerodynamics Department and later their advanced design bureau. One of his projects, designed in conjunction with Kurt Tank, was the Ta 183. It greatly influenced the subsequent Russian MiG-15 jet fighter. A derivation of the Ta 183 design, the Pulqui II flew in Argentina after the war, built by former Focke-Wulf personnel who had fled to Argentina with other hardcore Nazi elements after the collapse of Hitler's "Thousand Year" Reich.<sup>10</sup>

Drawing from his experience gained on Martin's abortive Dyna-Soar development program and work accomplished by Dr. Alfred Eggers and others of NASA, Multhopp made his first sketches of a lifting body configuration then termed the A3-4. Multhopp's A3-4 had the following features:<sup>11</sup>

a. The configuration was a maneuverable lifting body having no essential surface components which would be destroyed upon reentry from an earth orbit.

b. The vehicle had a hypersonic lift to drag ratio of 1.2 or better, permitting a lateral range of 1000 miles. This would permit a recall to any preselected site at least once a day with emergency recall to a suitable location from every orbit.

c. Low-speed aerodynamics of the vehicle were suitable for making a tangential landing without resort to automatic controls.

d. The volumetric efficiency was as high as possible and usable space was distributed so that the center-of-gravity would be sufficiently aft to provide adequate vehicle control.

The A3-4 vehicle had a planform sweep angle of 13 degrees and a nose radius of 16 inches when sized to house 250 cubic feet of payload. While this configuration retained the same flat-bottom and lower boattail camber as the Aerospace A-3 in order to preserve the A-3's hypersonic L/D, the ellipticity of the cross-section had been increased in such a manner as to eliminate the sharp edges of the A-3 shape. These sharp edges generated undesirable separated flow over the afterbody upper camber and vertical fins. Positive camber was included in the body (the A-3 had negative camber) which allowed trimmed lift conditions at lower angles of attack, as well as a higher subsonic lift-to-drag ratio.

As lifting body study continued into the spring of 1962, Martin, under contract to the Government, pursued design development of three basic configurations: the modified M-2b (basically a NASA configuration), the A-3 originated by Aerospace Corporation, and the A3-4, Multhopp's design. Aerospace, being the technical eyes and ears of the government on this project, was working very closely with Martin on Program 698AN and this, as can

be easily understood, caused some configuration competition, particularly between the A-3 and the A3-4. This worked to the benefit of the government since it acted as assurance that the best of these two designs would emerge.\* In the spring and early summer of 1962, engineers at Martin and Aerospace worked long hours in trying to select between the M-2b, the A-3, and the A3-4. Wind tunnel tests had been run on the A-3. In April 1962 Martin committed its own funds to build a 20 percent scale model of the A3-4 and test it at the University of Maryland subsonic tunnel the first weekend in May.<sup>12</sup>

Armed with many engineering hours of work, valuable experience and the results of these early wind tunnel tests, the Martin Company proceeded to sell the A3-4 configuration over the A-3 and the M-2b.

The Martin Company selected six items of comparison and argued that a better configuration could be chosen although the new configuration retained many of the good features of the Aerospace A-3. The six areas of comparison were (1) slenderness, (2) flat versus round top, (3) fin location and size, (4) controls, (5) nose shape, and (6) weight and balance.<sup>13</sup>

---

\*It might be noted in passing, however, that Aerospace's strong internal bias favoring lifting bodies significantly hurt the chances of the think tank making supportive contributions to the sagging X-20 program which, by this time, needed all the friends it could get. The A-3 lifting body design, incidentally, was technically immature and extremely unsatisfactory. FDL's Alfred C. Draper had been called in to a meeting at SSD on the A-3 during this time period and questioned closely as to FDL work in the lifting body field. Draper presented results of studies on the FDL's own MDF-1, a much more satisfactory vehicle, and he had frequent subsequent meetings with Martin's Multhopp. The connection between MDF-1 and the so-called A3-4 which spawned SV-5 appears secure enough to be termed the "missing link" in the A-3 to SV-5 story. (Lamar and Draper interviews).



Martin engineers held that the A3-4 shape represented the best estimate of a reasonable compromise of the slenderness ratio. In the question of flat versus round top, data seemed to favor the more elliptical A3-4 design; continuation of its leading edge lines into a straight lined cross-section towards the end of the vehicle led to a triangular rather than rectangular base area which would offer some design advantages, such as the possibility of a central tunnel connecting the satellite mid-section and reentry body. Again, as pointed out by Martin, the fins of a hypersonic vehicle, as in the A3-4 design, should be placed at the upper sides of the rear body and tilted outward to add longitudinal stability--a solution to a serious design problem and somewhat akin to the famous "Vee tail" of the Beech Bonanza. Furthermore, as in all lifting body configurations, flaps, whether buried in the body contour or attached to the body and trailing aft, were considered for elevator (pitch control) and aileron (roll control) operations. Although additional wind tunnel and flight tests would be necessary before final design the base area of the A3-4 body was shaped of essentially three straight lines to form a triangle thus allowing the largest possible width for top and bottom flaps. Finally, the nose section of the A3-4 configuration consisted of an almost hemispherical piece with a 16-inch radius. In this design a very modest continuously curved ramp extended over the forward 50-inches of the body. Whether this was sufficient to generate a small position  $C_{m0}$  value at hypersonic zero-lift would be seen as tunnel test data became available. Modification of the ramp angle was relatively simple and its effect on the subsonic and transonic vehicle characteristics would be relatively slight.<sup>14</sup> \*

---

\*A more detailed presentation of Martin's argument may be read in Appendix C.

The Martin Company, from the above reasoning, offered the following conclusions and recommendations:<sup>15</sup>

Of the two configurations suggested as a backup to the A-3 shape, the slimmer A3-4 shape appears much superior to the modified M-2b. It retains the good features of the basic A-3 shape, in particular the flat bottom, a relatively small base and a more forwardly usable volume, and promises to attain much improved subsonic and transonic characteristics. The modified M-2b configuration has very little to recommend it. It should be considerably less attractive than the M-2b configuration developed by NASA. How sensitive this shape is to small modifications is quite evident from the NASA tests.

Since there is hardly a penalty associated with the change from A-3 to A3-4, it is strongly recommended that this modification be included in the wind tunnel program for the development of the 698AN configuration. The modified M-2b configuration would deserve attention only if the shortcomings of the basic A-3 shape were due to the flat bottom shape. So far there is not the slightest reason to suspect this.

And so, in the spring of 1962, the A3-4 began to draw attention of the aerodynamicists. Later in 1962 the A3-4 was to be redesignated the SV-5 by the Martin Company. The Aerospace A-3 was redesignated the SV-1 by Martin and unless this is known at the outset, reading through historical reports by Aerospace and Martin can become quite confusing.

In March of 1962, the Air Force awarded the Martin Company Contract AF04(695)-103 to:<sup>16</sup>

. . . develop an aerodynamic configuration capable of achieving at least 600 nautical miles of cross range maneuvering and capable of performing a tangential landing, and to develop an ablative heat shield material and fabrication technique capable of providing the configuration protection from the environment experienced in low-earth orbits and in the return and reentry to tangential landings from these orbits. Related subsystems studies were to be specifically limited to those required for proper analysis of the available wind tunnel test results and to those required to ensure compatibility of the heat shield design with related subsystems requirements.

Before this project (known as M-103) ended in December of 1963, 914 hours of testing were conducted in continuous flow wind tunnels, complementing 285 test shots in hypersonic impulse tunnels. The largest portion of this effort was devoted to aerodynamic force testing in all speed regimes in order to develop the external configuration of the vehicle. A small percentage of the effort was devoted to hypersonic heat transfer and pressure testing to obtain initial data on heat and pressure distribution over the vehicle.

It is now appropriate to outline the wind tunnel test program conducted by Martin from May 1962 to December 1963. The majority of these tests were conducted under Contract AF04(695)-103, but it is only fair to mention that the Martin Company did fund some of the tests. A summary of the tests conducted is contained in Table 1. \*

In April 1962, the Martin Company had committed funds to conduct a low speed wind tunnel test on the SV-5 configuration (Figure 7). Arrangements were made with the University of Maryland to test a 20 percent scale SV-5 in its subsonic tunnel the weekend of May 4-5, 1962. Following the concept of attacking the landing problems first, this test proved that the vehicle could land tangentially at fairly reasonable touchdown speeds and with a L/D of about 4.0.<sup>17</sup>

Encouraged by this first low speed test, arrangements were made to force test a 2.745 percent scale plastic model of the SV-5 in the Cornell Aeronautical Laboratory 48-inch shock tunnel on May 14 and 15, 1962. This hypersonic force test indicated the SV-5 had a hypersonic trimmed L/D of 1.2. This test resulted in the first major change in the original SV-5 configuration because it revealed the need for extending the length of the lower flaps.

---

\*An overview summary of this testing can be found in Appendix D.

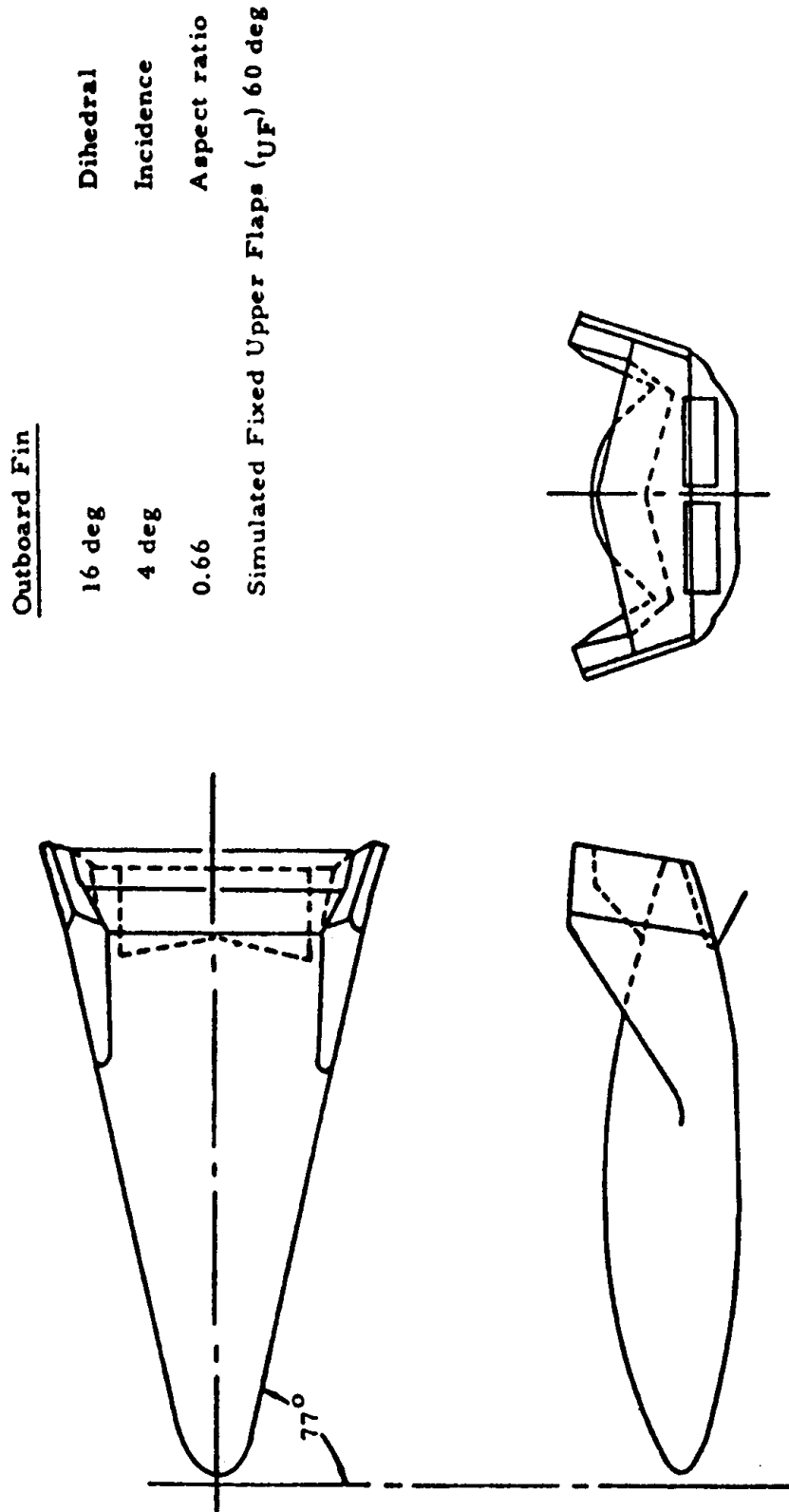


TABLE I: WIND TUNNEL TEST SUMMARY, MAY 1962 TO DECEMBER 1963

<u>Facility</u>	<u>Test Start</u>	<u>Dates Complete</u>	<u>Model Scale and Material</u>	<u>Type Test</u>	<u>Mach Number</u>	<u>Reynolds No. Based on Model <math>l</math></u>	<u>Test Shots or Runs</u>	<u>Test Hours</u>	<u>Test Report Number</u>	<u>Purpose</u>
Univ of Md	12/17/62	12/21/62	20% pine	Force	0.2	$6.47 \times 10^6$	76 runs	48	ER 12866	Subsonic evaluation of body and fin modifications
Univ of Md	1/28/63	2/9/63	20% pine	Force	0.2	$6.47 \times 10^6$	214 runs	92	ER 12867	Subsonic stability and control effectiveness
Univ of Md	4/5/63	4/6/63	20% pine	Force and pressure	0.2	$6.47 \times 10^6$	21 runs	16	ER 12995	Evaluation of pressure distributions on fins
Univ of Md	5/13/63	5/18/63	20% mahogany	Force and pressure	0.2	$6.47 \times 10^6$	61 runs	50	ER 12964	Evaluation of fin incidence and twist on directional stability
Univ of Md	6/26/63	6/29/63	20% pine and mahogany	Force	0.2	$6.47 \times 10^6$	45 runs	40	ER 13094	Subsonic evaluation of body and fin modifications
Univ of Md	10/21/63	10/25/63	20% mahogany	Force	0.2	$6.47 \times 10^6$	80 runs	30	ER 13203	Subsonic stability and control effectiveness
Princeton Univ	12/10/62	12/14/62	10% fiber glass	Smoke	0.027	$0.44 \times 10^6$	39 runs	40	ER 12801	Low speed flow study
Ames 6 x 6	9/25/63	10/8/63	4.6% stainless steel	Force	0.25, 0.65, 0.8, 0.91, 0.96, 1.0, 1.21, 1.6, 2.21	$2.0 \times 10^6$ $3.6 \times 10^6$ $2.3 \times 10^6$	195 runs	112	ER 13202	Definition of transonic stability and control effectiveness
Langley 8 Ft	4/18/63	4/26/63	10% aluminum	Force	0.5, 0.7, 0.9, 0.95, 1.0, 1.2	$6.4 \times 10^6$ to $9.8 \times 10^6$	158 runs	112	ER 12965	Evaluation of transonic stability and control
Langley 4 Ft Pressure	3/20/63	4/2/63	4.6% stainless steel	Force	1.61	$3.0 \times 10^6$	58 runs	88	ER 12967	Exploratory tests of supersonic stability and control
Langley 4 Ft Unitary	5/22/63 6/10/63	5/29/63 6/11/63	4.6% stainless steel	Force	2.29, 2.92, 3.95, 4.63	$2.6 \times 10^6$	107 runs	96	ER 12967	Evaluation of supersonic stability and control
Arnold Tunnel A	10/21/63	11/1/63	4.6% stainless steel	Force	1.98, 2.99, 4.0, 5.0	$4.0 \times 10^6$	158 runs	80	ER 13206	Evaluation of supersonic stability and control
Arnold Tunnel C	12/18/62 1/7/63	12/26/62 1/8/63	4.6% stainless steel	Force	10, 15	$1.42 \times 10^6$ and $0.33 \times 10^6$	135 runs	70	ER 12862	Hypersonic performance and lower flap effectiveness
Arnold Tunnel C	10/15/63	10/17/63	4.6% stainless steel	Force	10.1	$1.78 \times 10^6$	85 runs	40	ER 13205	Hypersonic performance, stability and control
Arnold Hot Shot 2	1/15/63	1/22/63	2.745% renite plastic	Force	18.4 to 19.6	$0.056 \times 10^6$ to $0.164 \times 10^6$	10 shots	40	ER 12863	Evaluation of hypersonic viscous parameter
Martin Hot Shot	10/9/62 12/7/62 3/19/63	11/12/62 12/17/62 4/12/63	2.745% renite plastic	Force and oil streak	20	$0.05 \times 10^6$ to $0.2 \times 10^6$	86 shots	400	ER 12963	Hypersonic performance flap effectiveness, and directional stability
Martin Hot Shot	7/26/63	8/27/63	2.745% renite plastic	Force	20	$0.235 \times 10^6$	78 shots	240	ER 13198	Hypersonic performance
Martin Hot Shot	9/12/63 10/29/63	10/9/63 11/8/63	2.745% renite plastic	Pressure	19.6	$0.076 \times 10^6$ and $0.25 \times 10^6$	50 shots	224	ER 13254	Hypersonic pressure distributions
Martin Hot Shot	11/19/63	12/23/63	2.745% renite plastic	Heat transfer	20	$0.085 \times 10^6$	61 shots	252	ER 13255	Hypersonic heat transfer distributions



Figure 7



Having explored the extreme ends of the flight spectrum with encouraging results, Martin gained support from the Air Force and reserved time in NASA's Langley Research Center's 8-foot transonic wind tunnel beginning June 11, 1962. A 10 percent scale model was constructed with various upper and lower flap and rudder deflections. During the tests it was quite obvious that transonic speeds would be problematical for this type configuration. At Mach numbers close to 0.7, the flow over the upper surface accelerated to a Mach number of 1.0 and a normal shock was formed locally. The boundary layer on the upper body surface could not traverse this normal shock without separating, resulting in ineffectual flow over the upper flaps and fins. The vehicle was unstable and controls were not usable for trim.

A simple solution to the problem was devised and tested immediately at Langley. The upper and lower flaps were deflected to 30 and 20 degrees respectively, simulating dive brakes on a conventional aircraft. This relieved the separated flow over the upper body and fins and the vehicle stabilized and exhibited small pitching moment changes with Mach numbers. Lift-to-drag ratio would suffer during this period of flight, but pilots preferred to decelerate through this transonic range as quickly as possible.

Later in June, tests were planned in the Martin Hot Shot Wind Tunnel using the 2.745 percent plastic model. Results of this series of tests proved that the vehicle was trimable and controllable in pitch at Mach 20.

During July 1962, Martin model designers and manufacturers were busy working on three new wind tunnel models for planned tests. The University of Maryland 20 percent scale model was converted for use in the David Taylor Model Basin Wind Tunnel. A new, more elaborate 10 percent scale model for the Langley 8-foot transonic tunnel was being manufactured as was a new 4.6 percent scale model for use in hypersonic tests at Mach 10 in



Arnold Engineering Development Center's (AEDC) Tunnel C. These three test series never materialized as planned because in late July 1962 the Air Force withdrew its support of the SV-5. Although Air Force support was not restored until late November 1962, this time was not all lost due to the perseverance of the Martin Company. Tests were run at the University of Maryland and in the Martin Hot Shot Tunnel in order to expand on data in subsonic and hypersonic flight. The hypersonic force tests provided information on the vehicle's longitudinal stability and control and an understanding of hypersonic Reynolds number effects.

The University of Maryland subsonic tests investigated fin aspect ratio, dihedral, thickness, camber, twist, incidence and fences in an attempt to increase trim L/D. Generally, fin modifications which increased lift, also increased induced drag with little effect on L/D. Since the maximum lift coefficient and the directional stability derivative were lower than desired, tests were run on ventral fins. Ventral fins provided good directional stability but violated the ground rule that all surfaces must survive hypersonic reentry. Also, the use of ventral fins was proven unsound at the time because of interference with upper fin structure and heat shield as well as ground clearance.

During this time period, it was shown that deflection of the upper flaps as ailerons produced yawing moments requiring rudder deflection to trim which in turn required more aileron deflection, and so on. An easy solution to the problem was installation of a center vertical fin. From this point on, the SV-5 was a three-finned configuration.

In October 1962, it was becoming quite evident that low speed improvements to the SV-5 would present a formidable task. Interference effects between the body, fins and control surfaces made conventional aerodynamic theories ineffective. Tuft studies

indicated spanwise flow over the trailing edge of the fins but removal of the fins greatly reduced vehicle lift. This suggested observing the flow just outside the boundary layer in order to determine vortex and interference patterns. It appeared a low-speed smoke tunnel at Princeton University might do the job. It was then late November 1962 and Air Force restored support.

Two models were made for the Princeton tests. One was the basic SV-5, and the other had a reduced slope on the upper boattail and a general flattening of the aft cross-sections. The latter had superior flow characteristics and hence formed the basis for yet another improvement to the SV-5. These changes were incorporated into a new 20 percent model which went back to the University of Maryland Low Speed Tunnel in December 1962.

That same month, renewed Air Force support gained tunnel time in the Arnold Engineering Development Center Mach 10 Tunnel C for the 4.6 percent model built earlier in the year but not yet used. Directional stability was found to be almost nil, but a simple solution was found by merely deflecting the rudders outboard about 10 degrees. An indication of heating rates over the body at hypersonic speeds was obtained using heat sensitive paint and injecting the model quickly into the airstream. This test further ruled out ventral fins as highly undesirable.

As the year 1963 began, Martin busily studied the dynamics and control effectiveness of the SV-5. The first real mapping of the control effectiveness of the SV-5 at Mach 0.2 resulted from wind tunnel tests at the University of Maryland in late January 1963. A new fin design with an increased leading edge radius was tested along with tests on a decreased aspect ratio (from 0.66 to 0.19) shape. The new fin design decreased the subsonic L/D, so it was abandoned.

By March 1963, the mathematical model of the vehicle's dynamics was well along. This "match" model was to be improved with

data from supersonic tests in the Langley 4-foot pressure tunnel and the 4-foot unitary tunnel, and these tests ran from March 20 to June 11, 1963. However, supersonic tests revealed some unforeseen problems in stability and control of the SV-5. In the region of Mach numbers 2 to 4.5 the vehicle was not trimable or longitudinally stable at low angles of attack with available flap deflection. Raising the upper boattail flaps to approximately 65 degree angle-of-attack brought the SV-5 into longitudinal trim by reducing the lift on the rear of the vehicle, but in doing this, the longitudinal stability was little improved. Also, the 65 degree flap position left little or no control remaining, and control laws became difficult to derive. This problem was alleviated at low supersonic Mach numbers of 2 to 3 by using fixed body nose ramps. However, the nose ramps tested in the series at Langley had the undesirable effect of causing the vehicle to have too much nose up moment at the higher Mach numbers and low angles-of-attack. The solution to this problem was a slow trial and error process which did not show real improvement until the fall of 1963.

More problems arose in the Langley 8-foot transonic tunnel in April 1963. The 10 percent scale model which was originally worked on in July 1962 was used with 30 and 20 degrees upper and lower flap deflections. Control effectiveness runs were made at Mach numbers from 0.5 to 1.2. A loss in directional stability was manifested at angles-of-attack greater than 13.5 degrees at Mach 0.95 and extending to 23 degrees at Mach 0.5. Deflecting the rudders, as was done to solve this hypersonic problem, did not work, and the tests were ended without solution. Ironically the SV-5 now had proven hypersonic qualities - but its subsonic difficulties threatened to end its career before it had begun.

An all-out effort was underway in June 1963 to attempt to raise the stall boundaries of the SV-5 at angles-of-attack and

sideslip, and thus address the subsonic problem area. The January low-speed tests set these boundaries at 24 degrees angle-of-attack at zero sideslip and down to 14.2 degrees at 15 degrees sideslip. Parametric studies on the effect of fin incidence and twist with a cambered airfoil were conducted as well as wind tunnel tests of altered section characteristics of the outboard fins, but these produced no solutions. However, a rather large nose droop was placed on the early slab-sectioned fins with phenomenal results. Maximum lift coefficient exceeded 0.94 and stall boundaries at angles-of-sideslip appeared to be doubled. Parametric studies on fin droop and moderately cambered fins were made in June 1963 at the University of Maryland with excellent results. Maximum lift coefficient was on the order of 1.05, trim L/D was 5.0 and lateral directional stability was on the order of .0017, clearly an acceptable landing configuration.

July 1963 tests were underway in the Martin Hot Shot Tunnel in order to catch up with evaluation of configuration changes made in the first half of 1963. At this time, work began on a new 4.6 percent stainless steel model which incorporated the final nose design that removed a portion of the nose length and raised the lower sections giving an effective ramp. The new fin droop design was also incorporated.

The directional stability problem uncovered in April was again attacked beginning on September 25, 1963 in the Ames Research Center's 6-foot tunnel. Exhaustive control effectiveness studies were also conducted in these tests. It was found that to be stable in yaw, the vehicle need only to remain below 13 degrees angle-of-attack at Mach 0.9 and this angle increased rapidly on both sides of this Mach number. The same model was tested at AEDC Tunnels C (Mach 10) and A (Mach 2 to 5) beginning on October 15, 1963. Control effectiveness was mapped during both of these tests, and the revised nose ramp provided stable trim throughout the supersonic Mach number range at angles-of-attack near 0 to approximately 60 degrees.

It is interesting to trace a maximum L/D flight of the SV-5 from reentry to landing noting control positions as predicted on the basis of simulations and wind tunnel tests.<sup>18</sup>

At hypersonic Mach numbers only the lower flaps and rudders are effective. The rudders must nominally be held at 10 degrees braked position for directional stability. The lower flaps are positioned at the 20 degrees down position for trim at maximum L/D.

Moving down to supersonic Mach numbers the upper flaps must be positioned at approximately 40 degrees and final longitudinal trim is accomplished by using the lower flaps slightly at Mach numbers near 4 and with movement of the upper flaps off the 40-degree point at lower supersonic Mach numbers. The rudders must still be held outboard approximately 10 degrees for directional stability.

Approaching Mach 1 the transonic trim setting of approximately 30 degrees on the upper and 20 degrees on the lower flaps must be programed, and the rudders can be restored to 0 degrees.

Below a Mach number of approximately 0.5 the subsonic control position of rudders trailing-edge-in 10 degrees and upper flaps set up approximately 10 degrees is maintained for maximum L/D. The lower flaps are nominally in the stowed position.

Thus, near the end of 1963, Program M-103 was progressing smoothly to its objective of evolving at sound lifting body reentry vehicle configuration for the Air Force. Hypersonic wind tunnel testing continued throughout 1964 but with a significant change in viewpoint. And, in this connection, it is useful to fix upon the status of Program M-103 and the SV-5 configuration in late 1963 because in December of that year direction from the Department of Defense was given that was to affect the future of the SV-5 for the next four years.

On December 11, 1963, Secretary of Defense McNamara signed a short but very significant memorandum to the Secretary of the Air

Force. The second paragraph read simply, "It is requested that you terminate the Dyna-Soar (X-20) Program, effective no later than December 15, 1963." The third and last paragraph went on to say, "It is further requested that a program for the development of a Manned Orbiting Laboratory (MOL) be initiated. In addition, Program Element 6.34.09.87.4 - Advanced Reentry and Precision Recovery should be redirected and augmented." This decision affected the entire military space program. A pulse could be felt throughout most of the U. S. aerospace industry. Most people working on Dyna-Soar had heard cancellation rumors and felt the decision was impending. The Dyna-Soar program had three major objectives: First, to provide as much maneuverability during reentry from orbit as possible in order to investigate its contribution to a military useful vehicle; second, to obtain detailed information of an aerodynamic and heating nature for a radiatively cooled vehicle; and third, to obtain information on man's military usefulness in space. The simplest statement to be found regarding reasons for canceling Dyna-Soar was contained in the following memorandum to Dr. Brockway McMillan, Assistant Secretary of the Air Force for Research and Development, from Dr. Harold Brown, Director of Defense Research and Engineering (though signed by Dr. Fubini), dated December 11, 1963.<sup>19</sup>

With regard to the first objective, Dyna-Soar is intended to provide a lateral maneuverability of approximately two thousand miles on either side of the main path. This maneuverability is very much larger than that provided by the present Gemini vehicle. However, this maneuverability is obtained only by compromising the other spacecraft design features. Unless man's usefulness in space is so substantial as to require routine transfer from orbit to earth, high maneuverability is not needed. In that case, it would provide flexibility and reduce recovery costs. In the event repeated transfer should be required, a ferry vehicle must be specifically designed which would likely be considerably different than either Gemini or Dyna-Soar.

The second objective, that of obtaining aerodynamic and heating information, can be less costly obtained with

unmanned tests. For this reason, the Department of Defense Aerothermodynamic Structural Systems Environmental Test (ASSET) program is being broadened to study a wider variety of reentry conditions, materials and techniques than was provided by either Dyna-Soar or previous unmanned vehicle tests. ASSET is now funded at a level of \$8.5 million in FY64. Five million dollars from FY64 Emergency Funding will be added to broaden the program. In FY65 this funding will be \$15 million in addition to the \$6.4 million already in the budget.

The third objective of the Dyna-Soar program, that of determining man's usefulness in space, would not have been undertaken until the tenth flight. The new MOL program will provide for longer stays for the man in orbit, approximately ten times the volume for equipment and comfort, and thus give a much more fair test to man.

The ASSET project originally had complemented the X-20 Dyna-Soar program; now it would substitute for it, at least in part. The Boeing Company was the prime contractor for the X-20, and the Martin Company was selected to build the booster system (later the Titan III). After contractor selection, but prior to any hardware construction by Boeing, studies were conducted by Boeing and other contractors in order to reassess the Boeing configuration, regressing to a basic research standpoint. These studies, known as Phase Alpha, revealed there was a basic lack of information in aerodynamic heating, structural design, stability and control of the X-20 in the flight regimes through which it was expected to fly. The ASSET program would help to fill this void by using research data derived from an inexpensive, unmanned reentry glider test program.\*

Reorientation of the manned military space efforts in December 1963, and the associated scurry of activity, quickly

---

\*See Case Study IV.

reached the Space Systems Division of Air Force Systems Command (AFSC). The effects of this decision on lifting reentry technology were somewhat residual in nature when looked at from an overall viewpoint. Cancellation of the X-20 program aroused concern over the development of technology for lifting reentry from space. Consequently, when the establishment of the MOL program generated a possible requirement for a shuttle vehicle employing lifting reentry techniques, existing reentry programs were surveyed to determine whether reduction or augmentation of planned efforts could provide an alternate means of acquiring data and experimental verification of proposed techniques which were to have been derived from the X-20 program. The ASSET project was selected as best qualified for these purposes.<sup>20</sup> However, the inherent dynamics of the space field soon resulted in a broader and more sophisticated approach than the ambitious little ASSET.

In a December 16, 1963 letter to General Ben I. Funk, Commander of Space Systems Division (SSD), General Bernard A. Schriever, Commander of AFSC, assigned SSD lead division responsibilities within AFSC for management of the entire military manned space effort, including ASSET. General Schriever felt it necessary to consider the expansion of an ASSET type program beyond structural and thermodynamic studies to obtain hypersonic flight data during lifting reentry. He asked that a plan be prepared immediately covering the proposal for modifying or augmenting the existing ASSET program. The specific objective of this new program would be to settle basic design questions by using unmanned scale models that could permit furnishing the requisite data base prior to any decision initiating an advanced manned ferry vehicle such as might be required in support of MOL. He also asked that the plan be ready for his review on December 27, 1963 prior to its presentation to the Secretary of Defense on December 31, 1963.

The task of documenting proposed program approaches was assigned to the Mission Analysis Division (SSTAM) of the Advanced



Planning Directorate, under Colonel W. D. Brady. With the assistance of the Aerospace Corporation, the initial documentation and briefing were completed and presented at AFSC headquarters on the prescribed date. The plan was prepared on a compressed time schedule over the 1963 Christmas holidays. Lieutenant Colonel Sherm Hislop led most of the effort for the SSTAM group. Major G. S. Lewis and Captain C. A. Gentzel were that office's reentry experts who worked on the detailed aspects of the reentry program. Their inputs and conclusions closely agreed with those of the Research and Technology Division (RTD) and Aerospace Corporation. They prepared a briefing which offered several typical approaches, some of the trade-offs and problems, and suggested a threefold program:

1. advanced studies to define mission requirements and operational criteria.
2. a technology program to be defined by an in-house study effort during January and February of 1964.
3. a tentative outline of a ferry spacecraft development program (this was deleted before being briefed to General Funk on December 23, 1963).

During the briefing to General Funk strong disagreements arose between Aerospace and SSTAM because Aerospace had changed its position over the weekend, and now recommended canceling three of the ASSET shots and some full scale spacecraft flight tests (fortunately, ASSET went on untouched). This briefing initiated a series of iterations in which proposed approaches were modified or discarded, alternative approaches suggested, investigated, evaluated, revised, and additional documentation prepared. In early January, for example, headquarters requested that consideration be given to using the last of the Titan IIIC development shots and running the tests with a "battleship" reentry vehicle of approximately full scale size. This was probably as a result of some early X-20 problems in integrating the X-20 and the

Titan IIIC booster to withstand the high dynamic pressure of ascent with this lifting vehicle perched on top of the booster stack.

During January, Colonel Brady was detailed to the MOL program and the task responsibility passed to Colonel N. J. Keefer, Director, Research and Technology (SSTR). To establish the existence of a new program of which the existing ASSET program was one element of many, a substitute for the "Expanded ASSET" label was sought. After considering program philosophy and objectives, SSTR chose instead the title of "Spacecraft Technology and Advanced Reentry Tests" (START) and used it thereafter as the common name for the program.<sup>21</sup> At this point M-103 and START came together; later that month M-103 surfaced openly in the Air Force R&D community. It had been under a special access security cover until then, controlled by the Director of Special Projects (SAFSP). On January 23, 1964, Under Secretary McMillan directed that the M-103 project be transferred to the ASSET project (now START) as soon as possible. Future work on this project was directed toward two principle objectives:<sup>22</sup>

Augmentation of the scientific knowledge in the field of reentry technology, particularly as it relates to lifting body shapes provided with ablative type shielding and experimental flight tests of a vehicle with a hypersonic L/D ratio greater than 1.0 capable of returning 100 to 200 pounds of payload from orbit.

The Under Secretary requested completion of the transfer prior to February 10, 1964 when current funds on the program were to be exhausted. It was a bit confusing at the time, but whenever reference was made to the "expanded" or "augmented" or "expanded ASSET" program it was really a reference to Program Element 6.34.09.87.4, Advanced Reentry and Precision Recovery, and not solely to the ASSET project as conceived and executed by Cosenza and his cohorts. The actual funding of this integrated effort was extremely difficult to extract from records because events and decisions occurred swiftly during the early months of

1964. The most accurate sources available indicate that the ASSET project funding for FY64 and FY65 was planned at \$8.5 million and \$6.4 million respectively with nothing in FY66. The remainder of this Program Element (M-103, START, and future activities) was funded at \$5 million in FY64, \$15 million in 1965, and \$35 million in 1966. These figures represented the funding status in late December 1963.<sup>23</sup>

The ASSET project, contracted from and technically directed by the Air Force Flight Dynamics Laboratory of Research and Technology Division (RTD), immediately presented management problems for SSD. Communications were received on almost a daily basis during the initial management transition primarily setting forth the funding difficulties with which the program was beset. Further problems were generated by a failure in the flight of the second ASSET while launched in March 1964. The findings of the Failure Review Board and the remedial actions recommended did not satisfy all agencies concerned. Flight Dynamics Laboratory (FDL) proposed that the July 1964 launch be postponed to permit further study; a course of action that would have increased program costs by about \$2.0 million. SSD's insistence that the Failure Review Board be reconvened resulted in a hardware fix and a launch as scheduled. Nevertheless, as "parent" of ASSET, FDL retained both the best technical expertise and perspective when dealing with this program, skills SSD simply lacked.<sup>24</sup>

Another problem of immediate concern to the SSD program offices in the early months of 1964 was manpower. In December, Deputy for Technology (SST) officers were assigned as a working group to accomplish the initial documentation and briefing requirements. The workload placed on these individuals and their Aerospace counterparts by the requirements for revision of documentation and briefings to comply with guidance received during the previous briefing cycle rapidly absorbed their full

capacities. The management functions resulting from the acquisition of the ASSET and M-103 responsibilities represented an overload not easily absorbed. SST support to other task exercises within SSD precluded assignment of additional personnel to START from internal resources. As a result of insufficient manpower, program management had to function on a crisis-management fire-fighting basis during the early months of operation.<sup>25</sup>

Fortunately, this quickly changed. On March 6, 1964, a manpower package establishing a requirement for immediate manning at a level of eight officers with a build-up to fifteen officers by the second quarter of FY65 was approved by SST. Immediate manning was not forthcoming, but because of the imminent phase out of the 706 program it later became possible to detail three officers to START from this source, one in May and two in June, and by penalizing other functions within SST, three additional officers were detailed in June, bringing the total START personnel strength to nine officers. These internal actions enabled the task force to establish effective management control of a very diverse program.<sup>26</sup> As a result of the 706 phase out and reallocation of other spaces arising from the SSD review of "Limping Programs," fourteen officer spaces identified for assignment to START program requirements became effective authorizations as of the July 1, 1964 Unit Manning Document (UMD). Ten officers quickly received orders assigning them to the program as part of the initial cadre of the approved START Program Division.<sup>27</sup>

Funding posed its own challenges. On February 6, 1964, Lieutenant Colonel Hislop briefed Dr. Hall (ODDR&E) on the SSD activity to that time in defining the purpose and direction of future efforts in subscale unmanned reentry tests. He also gave a short briefing on the SSD position of what studies should be contracted to industry as a parallel effort toward advancing lifting reentry technology. On March 9, 1964, a message was received from AFSC headquarters clarifying funding status for FY64. It said

that the current released funding was at \$8.5 million and that \$5 million was added to the program from emergency funds but was placed in a deferred status until approval of the START program plan. One million of these deferred dollars were then released to sustain project M-103 through the end of March. (This "keep alive" funding for M-103 was to continue until the end of FY64.)<sup>28</sup> At this same time, early March, SSD was forced to request an additional \$4.2 million for continuing the ASSET portion of Program Element 6.34.09.87.4 for the remainder of FY64. The urgency of the situation was highlighted by the fact that the McDonnell Aircraft Corporation had been unfunded on ASSET since December and had announced it might stop work on ASSET after the second launch scheduled that month. The ASSET project made it through April and in May \$3.6 million was received which left a little breathing room for the new managers at SSD. Later in May an additional \$400,000 was released and committed. The booster failure on the March 24 launch of ASSET further complicated the funding problems.<sup>29</sup> Program M-103, as mentioned above, also had to pull teeth to keep alive in FY64. The \$1 million released earlier kept it alive until about June 10, but an additional \$250,000 was needed to sustain work to the end of FY64. In early June, \$4 million was released by DDR&E for START; however, \$3.75 million was deferred by Secretary of Air Force for Research and Development (SAFRD) until a program plan was approved. Obviously the funding status of Program Element 6.34.09.87.4 was bleak at the close of FY64.

In March, we find that Dr. McMillan and Dr. Alexander H. Flax, Assistant Secretary of the Air Force for Research and Development, were briefed on START on the twelfth of the month. This was a key event since it resulted in a lengthy letter containing additional guidance for START signed by Flax on March 16, 1964. The letter offered low-key but critical support. Flax's subsequent actions demonstrated his strong commitment not

only to START, but to all phases of lifting reentry research. At a vital moment when the McNamara regime had killed X-20 and seemed lukewarm to the entire lifting reentry effort, Flax became the strongest champion of such research within DoD. Thanks to him, SV-5 would thrive, though not without a prolonged and involved battle over roles and missions questions. His letter read in part:<sup>30</sup>

It was agreed to exclude from the objectives of this program the scale test of the Gemini reentry vehicle and the previously specified requirement for the development of a small payload recovery capsule. The objectives of this program are, therefore, now defined as:

1. To obtain by flight tests, basic aerodynamic and materials data, and other technical data pertinent to the field of lifting reentry vehicles, when such data cannot be obtained in ground test facilities with a reasonable degree of confidence in its validity.

2. To conduct flight tests for the purpose of acquiring design data and developing configuration characteristics pertinent to a future manned ferry vehicle when and if such a vehicle is required.

He requested a "white paper" showing the various alternatives to the START program since these more specific objectives were now laid out. Funding, for planning purposes, consisted of \$5 million for FY64, \$15 million for FY65, \$35 million for FY66, with FY67 left open. The paper should correlate the proposed size of the reentry test vehicles with costs, schedules and objectives. Launch vehicles to be considered included the Atlas, Titan IIIA, and the Titan IIIC. As vehicle size increased, factors to be considered were increased fabrication costs, increased engineering cost, and increased subsystem costs. Costs of integrating a large spacecraft with a Titan IIIC booster were to be based somewhat on Dyna-Soar experience. The paper should consider two flights of an SV-5 and two flights of a technically competitive vehicle, with a provision for backup flights. Planning was to include, where

possible, procurement arrangements which allowed for the introduction of new contractors on the basis of maximum competition. Dr. Flax directed that several items discussed at the March 12 meeting remain in the new plan. They were:<sup>31</sup>

1. The plan to augment the NASA supersonic-transonic test program with configuration of interest to the Air Force, provided such configurations are sufficiently different from the M-2b and HL-10 to justify the additional tests.\*

2. Continuation of the ASSET program as presently planned with modification of the sixth ASSET vehicle to support the enlarged hypersonic test program by including tests of ablative materials [ed: this, of course, did not occur].

3. Inclusion of advanced configuration studies, required for evaluation of design features of alternative lifting body configurations, including the applicability of variable geometry, alternative head shield designs, such as combined ablative radiative shields, and studies of configurations covering a wider range of L/D.

Pending approval of the START program, Martin Company development work was to continue at a funding rate and not to exceed authorized levels, with studies directed toward the more general aspects of configuration design and evaluation without commitment to a specific launch vehicle or flight vehicle size, though flight vehicle weight was not to exceed 1600 pounds. Dr. Flax asked for the "white paper" during the week of March 23. This "white paper" briefing to Dr. Flax and Dr. Hall, because of their committed schedules, was not given until June 30 when the subject was covered in a related briefing.

---

\*This was a reference, of course, to the M2 and HL-10 programs. By this time, Paul Bikle's engineers at the NASA Flight Research Center at Edwards AFB had flown a small M2 manned plywood demonstrator, towed behind high performance automobiles and then launched from 10,000 feet after towing behind a Douglas C-47. These flights had led to NASA's so-called "heavy weight" program for supersonic rocket-propelled M2 and HL-10 vehicles, and indirectly encouraged the PILOT effort, to be discussed subsequently, within the SV-5 program.

On March 24 and 25, 1964 Martin and the Air Force held a meeting at the company's Baltimore headquarters for the purpose of permitting an exchange of information between the Martin M-103 personnel and the engineering personnel of the now-defunct Dyna-Soar System Program Office. Lieutenant Colonel Curtis L. Scoville, Dyna-Soar Project Officer at AFSC headquarters, arranged for the meeting and was present along with William Lamar, Director of the Air Force X-20 Engineering Office, since they believed some of the technology gained by Dyna-Soar effort had application to the work being done by M-103 project personnel. Colonel Scoville requested that the group submit a report to AFSC covering any significant technical problems which might become apparent as a result of the meeting. Subsequently, this review team, chaired by Mr. Lamar, produced a valuable and comprehensive 44 page report on their review of the M-103 program and forwarded it to Colonel Norman J. Keefer at SSD.<sup>32</sup>

In April, an abbreviated technical development plan and the START "white paper" were forwarded up the chain-of-command to Air Force headquarters. Although personal contact was not made with Flax and Hall, these papers had resulted from their request. A number of hypersonic test programs were studied in attempting to satisfy the program guidelines set forth by the Department of Defense. The SV-5 configuration, which had already been intensively investigated by the Air Force, was chosen for all candidate programs. That configuration offered a potentially significant improvement in operational capabilities for lifting reentry vehicles and incorporated those design features which warranted flight test demonstration and evaluation at that time. The selection of vehicle scale was complicated by the conflicting objectives of low cost and high payoff. As a result, two principal alternative programs were suggested. One alternative attempted to maximize the technical return applicable to future ferry craft and employed a



large scale test vehicle weighing 12,000 pounds. The Titan IIIC was to be the launch vehicle. The other alternative attempted to minimize overall program costs through the use of a vehicle of approximately 1600 pounds weight. At the time, this size vehicle was considered to be the smallest possible commensurate with meaningful technology objectives. The large scale vehicle represented a vigorous step forward toward an eventual military manned space capability, whereas the small scale vehicle program, although of more limited long term value, would provide a significant advance in lifting reentry technology.<sup>33</sup> Also recommended at the time were concurrent activities in two other areas; investigation and study of advanced concepts and configurations for which a significant potential existed and mission studies of those future capabilities to insure the sensitive interdependent parameters between spacecraft technology and mission application were properly correlated. SSD would form a strong project office to tie together various command elements, the contractor's efforts, and properly coordinate the START program with related NASA programs. The size of the program office would remain small but be manned by competent and highly motivated personnel.

Execution of this plan necessitated some fast bureaucratic footwork. The time spans suggested in this recommendation were acceptable for completion of technical work but there was little time to spare for procurement action. Negotiation authority could not be requested, of course, before a specific program approach had been approved so it was requested that delay in processing the Determination and Finding (D&F) be minimized.\* Subsequent Request for Proposal (RFP), proposal and price analysis, audit and field support, negotiation and processing of a definitive contract would

---

\*A document frequently issued at secretariat level which permitted the buying agency sole source procurement.

probably have precluded meeting program dates. Therefore, knowledgeable staffers recommended a letter contract or similar unpriced contract action.<sup>34</sup>

Since it was logical to seek the benefits of cooperation with NASA, planners requested augmentation of the NASA lifting body test program in order to permit testing of the SV-5 in the subsonic, transonic, and supersonic regimes. It was suggested that coordination with NASA be achieved through the Manned Space Flight Panel of the NASA-DoD Astronautics and Aeronautics Coordinating Board.<sup>35</sup>

The "white paper" and abbreviated technical development plan forwarded to headquarters in early April were very well done, very comprehensive, and about 2 inches thick; they required some time to digest. By mid-June, Flax and Hall requested a briefing on June 30 comprehensive enough to constitute a clear and adequate basis for overall START program approval. Flax and Hall then dropped a minor bombshell, revealing that the release of \$4 million of emergency funds deferred in 1964 was predicated on DDR&E informal concurrence that the START hypersonic flight tests would feature the SV-5 configuration in a 4-flight program utilizing the Convair SLV-3 Atlas booster for a 3/4 orbit trajectory from Cape Kennedy with recovery near Hawaii. Flax added that the SV-5 vehicle should weigh no more than 1600 pounds, and that Atlas had been selected so as to allow flexibility in trajectories, terminal recovery systems, beacons, and in meeting the instrumentation or test requirements which could evolve in the course of the test program. The first launch would be in December 1966 and the last in September 1967. It was felt that these launch dates were compatible with funding of \$5 million in FY64, \$21.4 million in 1965, \$26 million in 1966, and \$17.3 million in FY67. The total cost of the program then envisioned was \$57.2 million of which \$37.2 million was allowed for reentry vehicle development under continuation of the M-103 contract. Sixteen million dollars went

for boosters and launch services, and four million dollars for flight test support. Funding requirements for the other adjunctive elements of the START program were estimated at about \$12.5 million resulting in a total START program funding of about \$70 million. The fiscal year funding as specified above included these adjunctive elements.<sup>36</sup>

At this time, Dr. Flax also requested that an updated technical development plan be submitted to DDR&E (Dr. Hall) by September 1, 1964. The ASSET project was not to form an integral part of this new development plan. So it was that by the end of June 1964, SV-5 was well and truly launched. An expanded ASSET was out; Titan had been replaced by Atlas; and the Air Force and Martin had a mandate to transform the SV-5 from a wind tunnel test article to a going hypersonic project.

## NOTES

1. Martin Program Plan, Program 202, ER 11588, Volume II, September 1961, p. 1.
2. Ibid., p. 1.
3. Ibid., p. 3.
4. Ibid., p. 3.
5. Martin Semiannual Progress Report, Program 698AN, ER 12160-1 July 1962, pp. 1-5.
6. Backup Program for Modified 698AN Configuration, Martin Report ER 12147, April 1962, p. 1.
7. Ibid., p. 2.
8. Ibid., p. 3.
9. Ibid., p. 5.
10. History of Aerodynamic Development of SV-5 Lifting Body, Martin Report, CR-98, December 1964, p. 1.
11. Ibid., p. 1.
12. History of Aerodynamic Development of SV-5 Lifting Body, Martin Report, CR-98, December 1964, p. 5.
13. Backup Program for Modified 698AN Configuration, Martin Report, ER 12147, April 1962, pp. 7-16.
14. Ibid., pp. 7-16.
15. Ibid., p. 17.
16. Program M-103 Summary Report, Martin Report, ER 13261, Volume I, February 1964, p. 1.
17. History of Aerodynamic Development of SV-5 Lifting Body, Martin Report, CR-98, December 1964. Much of the information in this Chapter was taken from this document.
18. Ibid., pp. 14-15.
19. DDR&E Memorandum for Assistant Secretary of the Air Force (R&D), Subject, "Manned Orbital Program," dated December 11, 1963.
20. Historical Report for Program 680A, 1 Jan 64 to 30 Jun 64, 5 Jul 64, p. 1.

21. Ibid., p. 1.
22. Memo., SAFRD to Hq USAF DCS/RD, January 23, 1964, subj: Transfer of Project M-103.
23. Memo., H. Brown, DDR&E to B. McMillan, SAFRD, December 11, 1963, subj: Manned Orbital Program.
24. Historical Report for Program 680A, 1 Jan 64 to 30 Jun 64, 5 Jul 64, p. 2.
25. Ibid., p. 3.
26. Ibid.
27. Ibid.
28. Ibid., p. 2.
29. Staff Summary Sheet, Colonel L. S. Rochte to General B. I. Funk, March 7, 1964, subj: New Obligation Authority for Program Element 6.34.09.87.4.
30. Memo., A. H. Flax, SAFRD to AFDCS/RD, March 16, 1964, subj: START Program, p. 1.
31. Ibid., p. 3.
32. Ltr., Colonel H. Dorfman, Hq AFSC to Colonel N. J. Keefer, SSD, April 6, 1964, subj: Review of M-103 Program.
33. Ltr., General O. J. Ritland, Hq AFSC to General J. Ferguson, Hq USAF (AFRDC), April 16, 1964, subj: START Program.
34. Ibid., paragraph 7.
35. Ibid., paragraph 8.
36. Program START, Hypervelocity Test Program White Paper, April 6, 1964.



CHAPTER II  
BUILDING MOMENTUM

On July 8, 1964 Dr. Alexander Flax signed the Determination and Finding (D&F) which allowed SSD to write a letter contract with the Martin Company and begin work on a project to augment the technology base, obtain basic aerothermodynamic data in the field of lifting reentry and provide design data for future manned ferry vehicles.<sup>1</sup>

The AFSC Management Report contained further important guidance. The AFSC's Manned Space Flight (MSF) was the responsible headquarters office, SSD was the responsible management organization, and Deputy for Technology, Space Reentry Program Division (SSTRS) was the project office symbol. Project 680A was the official numerical title of this new project and START was also designated an official title. Fiscal Year (FY) 1965 funding was estimated at \$30 million for this procurement. A cost-plus-incentive-fee (CPIF) contract was to be used for flight testing of the spacecraft. Cost, schedule and performance incentives were to be considered but precise incentive parameters were to be developed after program approval. The contract was to be awarded to the Martin Company on a sole-source basis for hypersonic flight testing of one selected spacecraft configuration. Other procurements were to be handled competitively, such as the contemplated studies. These procurements were to be in the areas of alternate configuration selection, advanced configuration trade-offs and system studies. Moreover, as stated in the AFSC Management Report:<sup>2</sup>

The program will encompass elements of the existing Aerothermodynamic/Elastic Systems Structure Environmental Tests (ASSET) Program, the existing M-103 program (begun under the Special Projects Office) and new Augmented

Reentry Tests (ART). More specifically, the START program will include the development and flight test of a hypersonic test vehicle, the flight test of a subsonic and transonic vehicle of the same configuration, and advanced configuration technology studies such as variable geometry configurations and alternate heat shields. These studies will include laboratory and wind tunnel tests. The START program will be coordinated with related systems studies. These related studies will be funded under program element 6.24.10.06.4 and will include such studies as Operational Potential of High L/D Spacecraft, Economics of Recovery and a pre-definition study which will establish preferred system design, assure compatibility with launch systems and recovery concepts, and investigate design flexibility for multi-mission concepts.

In mid-July DDR&E was interested in a 4-flight orbital program with a 48-inch wide vehicle. However, about this time, questions were being raised concerning the merits of a 5-flight suborbital program with a 40-inch vehicle. The Martin Company had briefed DDR&E in late December 1963 on this type of program and at the time had flashed a price tag considerably less than that required for the orbital program. Several deficiencies were found in the rationale behind the suggested 5-flight program using the Thrust Augmented Thor booster. First, the booster requirements exceeded its capabilities in pitch-over rates, maximum dynamic pressure and payload weight for such a trajectory. Martin had said a very large cost savings would result; however, when booster mods were figured in, along with additional items overloaded, the cost savings were minimal relative to the technology lost in reducing vehicle size.

The letter contract with Martin was signed on August 14. The work on M-103 continued through June and July at Martin so that no loss in continuity was suffered as M-103 became a real flight test program.<sup>3</sup>

In mid-July 1964 Lt. Col. Scoville, the START Program Director, arrived at SSD and found himself immediately flooded with work. The technical development plan was being rewritten,



briefings were being prepared for Hall and Flax, the letter contract was about to be signed, and the ASSET ASV-3 vehicle was to be launched. The major task to be accomplished over the next few months, however, was securing program approval. One of the problems that often plagues program offices that begin on letter contracts is delay in definitizing the letter contract. These delays result in man-hours expended without positive direction and expenditure of funds on tasks which do not contribute fully to the achievement of program objectives. Special efforts were made by the new program director to avoid such a mistake.

A message was received on July 28 requesting more information on the advantages of up-down trajectories rather than orbital shots in START. The SSD reply to the initial query disposed of the Martin trajectory and booster selection, but it did not answer the basic question of whether additional data and technology, resulting from the 3/4 orbit flight test program, was worth the substantial cost differential over an up-down program. A briefing was therefore requested on this subject for Dr. Flax during his visit to the west coast from August 3-7. As events turned out, the briefing was not given on the west coast that week, but rather in Washington the following week. Lieutenant Colonel Scoville and Mr. Barry Moss of Aerospace gave the briefing to Generals B. I. Funk, O. J. Ritland, and R. D. Curtain before delivering it to Drs. Flax and Hall on August 11-12, 1964. Mr. Moss was the Program Manager at Aerospace.<sup>4</sup> Flax was pleased with the briefing and asked several detailed technical questions. Near the end he asked what the program would look like if the funds were limited to a total of \$40 million. He requested a memorandum in response to this question and suggested the briefing be given to Hall the next day.<sup>5</sup>

Hall was briefed on the afternoon of August 12, 1964. During the preliminary discussion regarding the subject briefing, Hall

indicated that the primary interest at DDR&E level had always been in returning a data capsule; therefore, when discussion of an operational vehicle occurred, it was to be understood that the operational vehicle might be a data capsule. He wanted to know if the program could be designed so as to produce an operational data capsule and yet provide the technology information needed, and whether an orbital test would support a data capsule as well as provide needed information for any full-scale vehicle. The questions required some analysis, and sent program advocates scurrying for answers. He also revealed that the Department of Defense desired a vehicle weighing about 400 pounds (in contrast to the 1600 mentioned earlier) and pointed out that recovery of a data package was essential.<sup>6</sup> At this point a major philosophical difference arose, centered on the data capsule issue. Dr. Brockway McMillan, briefed the same day, said that no reference should be made to data capsules in START program objectives! With this conflict existing, it was imperative that Dr. Harold Brown, then Director of DR&E, get into the matter and make the final decision. Scoville and Moss returned to the west coast understandably confused after their series of briefings.

Continuing on the course of action planned before this trip, the START Program Technical Development Plan (TDP), containing a four-flight, 3/4 orbital test program, was forwarded to Gen. Ritland at AFSC headquarters on August 17. Up to the Hall-Flax briefings it was fairly clear that SSD was authorized to let a contract for the Alternate Configuration Study at a cost of about \$500,000. However, after this point, there was serious doubt whether this was actually the course desired by DDR&E. It was decided to hold off on this study for a while.<sup>7</sup>

Brown's intervention late in the month restored some order to the program. On August 27, 1964, he signed a memorandum for the Under Secretary of the Air Force on the "START Program." The memorandum was of paramount importance in establishing START program

guidelines. First, he briefly reviewed program objectives; flight testing of an unmanned maneuverable reentry vehicle capable of returning small payloads from orbit " . . . and a secondary objective in the scientific field."\* The memorandum then went on to list the following points that seemed " . . . germane to the proposed projects."<sup>8</sup>

1. A maneuvering reentry vehicle for data return must demonstrate that it can provide for precise recovery of reasonable payloads without incurring excessive increases in over-all weight.

2. A vehicle designed specifically for testing this concept may be limited in the amount of instrumentation it can carry for scientific purposes.

3. No flight test data exist on maneuvering reentry vehicles and therefore flight data properly chosen on any of several configurations could be very useful.

4. The flight of full-scale ferry vehicles can involve aerodynamic regimes that may be difficult to test with small vehicles.

5. It is possible that NASA may wish to direct the development of a maneuverable reentry vehicle at some future time.

In light of the above, wrote Dr. Brown, the primary purpose of the START program, testing the flight feasibility of unmanned

---

\*Ed. note: It is interesting, though perhaps not surprising in light of Brown's key role in killing Dyna-Soar, that he would perceive the SV-5's reentry research as a "secondary" objective, and dismiss it so relatively casually. Ironically, of course, it was SV-5's research objectives that, in the end, justified the entire program.

maneuvering reentry data return vehicles, was the only " . . . useful mission at this time." Moreover, other scientific objectives which sprang from interest in a manned ferry vehicle " . . . should be regarded only as by-products of the primary mission." Therefore Dr. Brown requested:

1. That the Air Force, in its submission of a TDP (insofar as the present state-of-the-art permits) show that the critical reentry factors inherent in a practical data return vehicle for small payloads (25-80 lbs nominal) will be tested by the flight test configuration proposed for START.

2. That should the Air Force propose to test a vehicle larger than that which might be considered as a prototype of the data return vehicle, it show:

- a. The critical flight regimes are representative.

- b. The scientific instrumentation is highly desirable.

- c. The incremental tests represent a small percentage (10%) increase.

3. That if the time to obtain a prototype test of a data return capsule is delayed by the testing of a larger vehicle or costs increase by more than 10%, the Air Force provide for consideration of separate plans for (a) a data return prototype to be tested by the START program and (b) a second program intended as a predecessor of a manned ferry application.

There was still a fair amount of flexibility left in forming the START program but it was gratifying at the time to get some crystal clear direction.

In late August, General Bernard Schriever met with Mr. W. B. Bergen, President of the Martin Company, to talk about

the SV-5. In particular, the discussion centered around the low-speed manned vehicles envisioned to be flight tested at Edwards Air Force Base, including a rocket powered vehicle air launched from a B-52 and capable of reaching Mach 1.8 and a jet powered one able to take off from the ground. The latter (ultimately rejected on safety grounds) would provide a useful training vehicle for the Aerospace Research Pilot School at Edwards. These two would fulfill supersonic, transonic, and subsonic performance and handling qualities roles, would furnish data for operational planning, and provide needed training of potential ferry vehicle crews. The exact conclusions reached between General Schriever and Mr. Bergen were not recorded. This discussion, however, may be considered the starting point for the PILOT program (discussed subsequently) which spawned the X-24A and, indirectly, the X-24B as well.<sup>9</sup>

The first START Program Review meeting was held at Martin-Baltimore on July 23 and 24, 1964. These meetings were initiated by Lieutenant Colonel Scoville to facilitate an exchange of information between the government and industry organizations working on the program. At each of these meetings the members present would report the progress in their respective areas, with emphasis on problems and problem solutions. As a useful by-product, these meetings were to become a significant factor in generating team spirit in the overall program.\*

On September 9 SSD responded to Dr. Hall's query on the 400 lb vehicle and data capsules in general. SSD had concluded that an operational data capsule of 400 lbs was not feasible since this would be the minimum weight of the SV-5 without a payload. An operational data capsule of 500 lbs weight would provide for 50 lbs payload and if this space were replaced with

---

\*A description of the philosophy behind these meetings is contained in Chapter IV.

instrumentation, about 135 data points could be gained for the flight tests. This amount of instrumentation was not considered adequate for a genuine hypersonic technology based program. A 950 lb vehicle would have 160 lbs of payload capable of furnishing 370 data points. It was also felt that the subsystems, structure and heat shield needed for the small data capsule concept would require major development compared to flying a more reasonable 48-inch vehicle. SSD's response stated emphatically that if the START program objectives were altered to emphasize the data capsule operational mission and to minimize the requirement for lifting body reentry technology, then other vehicle geometries and concepts should be considered and studied relative to a given requirement for maneuverability. Much simpler shapes than the SV-5 were known to have comparable crossrange capability but lacked potential for tangential landing. It was also made clear that flight tests required to meet the current START program objectives would require more than a total program funding of \$40 million. (SSD eventually won this critical philosophical battle over SV-5 roles and missions.)

The second Program Review meeting was held at SSD on September 10-12, 1964. The Martin Company was being guided in one direction even though overall program objectives seemed quite fluid at the time Martin was basing their work on using an Atlas booster in a 3/4 orbit from Cape Kennedy. Recovery was to be in the air after flight termination at about Mach 2 and 80,000 feet altitude. Vehicles were to weigh about 1600 lbs and were the 48-inch width type. Wind tunnel tests were planned for subsonic, transonic, supersonic, and hypersonic regimes, including several Mach 10 tests at Arnold Engineering Development Center (AEDC), Tennessee.<sup>10</sup>

Dr. Brown held a meeting on September 23, attended by Drs. E. C. Fubini (Deputy Director of DDR&E until December 1965), Hall and Flax, to discuss the START program. Attention was given

to whether the objectives of the START program should be changed from the technology effort to developing a prototype of an operational data capsule return vehicle for national security missions. Records indicate that Dr. Flax did not want to take a position on that subject and requested two weeks for additional consideration. DDR&E took a rather firm position on this line backed by the Brown memorandum of August 27 that the data capsule mission was the only mission that, at the time, DoD could justify and support. Obviously, then, DDR&E (despite its general support for SV-5) felt that the technology effort leading to a possible future manned spacecraft was an effort of secondary interest to the data capsule.<sup>11</sup>

Dr. Hall visited SSD the week of September 21, 1964. On September 25 he was briefed on the START program and the data capsule concept. General B. I. Funk, General P. T. Cooper, Dr. Ivan A. Getting (President of Aerospace), and Dr. A. F. Donovan of Aerospace were present. Lieutenant Colonel Scoville and Mr. Moss delivered the briefing. A 28-inch, 500 lb vehicle was shown that could return an 80 lb payload. Also discussed were a 48-inch, 1800 lb vehicle and a 35-inch, 960 lb vehicle. These were compared parametrically with Maneuverable Ballistic Reentry Vehicles (MBRV) of various sizes from 400 to 3300 lbs. Briefers then showed the number and kind of instruments that could be flown on each size vehicle.<sup>12</sup>

After the briefing much discussion ensued. Dr. Hall said that DDR&E was now interested in comparing the 28-inch and the 48-inch vehicle in order to determine what technology questions could be answered by each. Mr. Donovan stated that the best data capsule would be a derivation of the MBRV but that the SV-5 shape was best for any potential manned application. He emphasized that

in the flight test of the SV-5 the size should not get too small or serious scaling problems could exist of unknown intensity.\* Moreover, the SV-5 was just not the best configuration for a data capsule. What were the data capsule requirements? Dr. Hall asked rhetorically; the requirement for a data capsule was not written down. At the time it was thought of as an advanced program in which technology for data recovery would be developed in order to obtain a data capsule in the near future if the need arose. A cone-shape was of interest. Mr. Donovan stated that a data capsule would not require multi-sonic capabilities like the SV-5 and, in fact, the 1800 lb vehicle was too small for a multi-sonic capability. Dr. Hall said that he saw three alternatives: (1) fly the 1800 lb (48-inch) vehicle and then decide what to do next, (2) fly the 28-inch vehicle to demonstrate maneuvering data return, or (3) introduce a new question as to what could be hoped for in subsonic capsule maneuvering or whether the requirements for maneuvering and data capsules were compatible. Dr. Hall also said that he would talk with Dr. Flax in the next two weeks in order to decide what direction would be taken. He said that if a data capsule program could be put together which gathered much technology and led to subsonic performance it would be bought immediately.<sup>13</sup>

Apparently, Dr. Hall talked with Dr. Flax immediately because on the following work day a memorandum was signed by Dr. Flax, entitled "The START Program." This memorandum, written to the Air Force Deputy Chief of Staff for Research and Development, and referencing Dr. Brown's earlier memorandum, addressed the problem of

---

\*Scaling effects relating the size of wind tunnel or free-flight models to full size flight vehicles have always posed nagging and uncomfortable problems for aerospace developers. SV-5 was no exception to this general trend. As a rule, the smaller the model, the greater the potential scaling effect problems.



whether the objectives of DDR&E and the Air Force could best be realized from the START program by redirecting the program toward data capsule recovery, a DDR&E objective, as the primary mission while retaining the planned reentry shape to permit hypersonic research as a secondary consideration. Said Dr. Flax: "Since the balance between primary and secondary objectives must be established in terms of specific program plans and goals in relation to costs, it will be necessary to consider several alternatives." The Systems Command and the START Program Office were to analyze and evaluate these alternatives without limiting their considerations to the SV-5 as the program's research vehicle. Alternatives to be investigated, as listed by Dr. Flax were:<sup>14</sup>

1. The program based on a 48-inch SV-5 configuration, essentially as described in the technical development plan for program 680A dated August 1964.

2. A program based on the SV-5 configuration directed toward a data capsule recovery vehicle having a nominal weight of 500 lbs, a hypersonic L/D of 1 to 1.4 and capable of unmanned maneuverable return from orbit of 80 lbs of payload.

3. A program based on a prototype operational data capsule design not constrained by limitation to the SV-5 configuration. The configuration of this design is to be chosen on the basis of minimum cost, earliest availability, greatest simplicity and minimum development risk. The requirements for this vehicle shall be the return of 80 lbs payload from orbit with a hypersonic L/D of 1.0 to 1.4. Usable Payload Volume should be in the order of one cubic foot. Full consideration should be given to the relationship of this alternative to the Air Force efforts currently underway on the Maneuverable Ballistic Reentry Vehicle Program, and a specific comparison of vehicle characteristics should be made. Although it will be possible to use this simplified vehicle to conduct certain advanced technology experiments, it is recognized that this approach may require a separate program to obtain data relating to future manned vehicle capable of subsonic maneuvering and horizontal landing.

Furthermore, wrote Flax, comparison of these alternative programs should be made from the standpoint of meeting certain defined objectives: (1) contribute to development of an unmanned maneuverable vehicle capable of returning approximately 80 lbs from orbit, (2) contribute to advancing the technology of lifting reentry vehicles, related materials, and aerodynamic and structural design, (3) and further configuration development for manned ferry vehicles. Additionally, "Attention should be given to total program content, including booster costs, flight test mode, schedules, and extent to which the above listed program objectives can be met by each program." Data capsule design should be considered in terms of its " . . . capability for deorbit, lateral maneuver and terminal control for precision recovery." Various possibilities for recovery, by parachute, deceleration devices or terminal guidance in either or both subsonic or supersonic speed ranges should be sought. The START program managers were reminded that, "The latter factors need not be considered in great detail but are intended to disclose the potentials for precision recovery which may depend either on the aerodynamic characteristics of the data capsule or the modes of recovery chosen."

This detailed review of alternative programs was to be completed " . . . no later than October 15, 1964." Finally, the Air Force was instructed that, until the analysis task was completed and action taken to continue or redirect the program, " . . . contractor effort should be devoted to consideration of these program alternatives. Other technical efforts relating to the SV-5 configuration should be limited to activities which are essentially independent of the vehicle size which is finally chosen."

SV-5 was clearly in a state of flux. When the M-103 program was transferred to SSD, the objectives were ablative heat shield reentry technology of lifting bodies and a payload capability of

100 to 200 lbs. In mid-March, the reader may recall, the Assistant Secretary of the Air Force for Research and Development, in a memorandum, deleted the requirement for a small payload recovery capsule and restricted program objectives to development of reentry technology and manned ferrycraft configuration characteristics. The two later directives, one from Dr. Brown and the above from Dr. Flax, appear to refer to the earlier objectives; namely, reentry technology and payload recovery from orbit. The payload requirement was now 80 lbs rather than the earlier 100 to 200 lbs.

As these conflicting objectives strained the abilities of those seeking to create a firm program, it seems appropriate at this time to gain a focus of the total picture. Technically, a small data capsule return SV-5 could be generated, though trade-offs might greatly restrict its value. Due to the smaller size, the vehicle could acquire only about 65 aerodynamic and materials data points per flight if engaged on hypersonic research. Nevertheless, the SV-5 shape could satisfy both data capsule or manned ferry objectives. If the data capsule objectives were to hold, the important aspect of testing a configuration at all pertinent Mach numbers could still be achieved, though with some compromises. The combined START program and NASA low speed manned drop tests would support both efforts. By testing a 500 lb SV-5, a near-prototype data capsule could be developed. Whatever approach was to be used, a useful by-product of these tests would be configuration data useful in the design of a manned ferry spacecraft whenever the requirement arose. Needless to say, however, a more sophisticated, purely research-oriented SV-5 shape would be the best option of all for hypersonic researchers.

With redirection "in-the-air," approval of the Technical Development Plan (TDP), even with exceptions, seemed unlikely to occur very soon. Release of FY65 funds for START was dependent

upon approval of this TDP. In light of these facts, it was difficult at best to try to predict what sort of funding coverage could be expected until program approval was secured. The contractor had been directed to curtail his expenditure rate so that released funds would cover contractual effort through November. November was only one month hence. A great deal of effort had been expended to get the program underway. To scrap the whole approach and start with a new configuration would delay flight testing at least a year; this, however, seemed to be a dangerous possibility based on headquarter's memoranda.

Approval of this program did not appear to be hindered by any political overtones. If there were, they were not evident at this time. Both NASA and the Air Force had to be - and were - very careful in both internal memoranda and external appearances (such as in Congressional testimony) not to appear as advocates of a complex orbital manned lifting body effort to replace the defunct X-20.

Flax again visited SSD on October 6 and was briefed by Lieutenant Colonel Scoville and Moss. Scoville gave the status of the START program and Moss briefed on the results of studies on possible data capsules that could be developed. Flax also contacted General Funk, Dr. Getting and Mr. Donovan during his visit. He suggested that a briefing be prepared for Fubini, rather than the white paper that had been planned and which he felt would not be read. A date and time were agreed on that were compatible with both Flax's and Fubini's schedules. The time was the afternoon of October 16, 1964 in Washington, D.C. The time had come to decide exactly what START and SV-5 were about.<sup>15</sup>

The briefing proved the single most important event in the development history of the START program. It resulted in program

approval and set forth objectives which remained unchanged for the duration of the program. Colonel Norman J. Keefer, Lieutenant Colonel C. L. Scoville and Mr. B. Moss flew to Washington on October 14, 1964. The briefing they carried with them was entitled "START/Capsule/Technology/Ferrycraft." The ferrycraft portion was included in response to a request by Dr. A. H. Flax.

The first portion of the briefing discussed missions for the ferrycraft, data capsule, and hypersonic technology missions. Briefers emphasized that lifting bodies had a wide range of capabilities and potential uses. The second part of the briefing dealt with technology considerations relevant to START. Briefers discussed technology requirements for thermal protection, aerodynamics, structures, guidance and control, communications, and flight test analysis. They reported on current reentry simulation capabilities in facilities of the United States, and examined aerodynamic problems such as boundary layer transition and sizing effects with special emphasis since they were aware that Fubini, Hall and Flax were all well respected within the aerodynamics community. The next item discussed was the 48-inch vehicle flight test program the Air Force hopefully envisioned. The briefing's vehicle description included its aerodynamic characteristics as predicted from wind tunnel tests. Reentry heating predictions were shown as well as the planned instrumentation system for that size vehicle. The launch configuration displayed was the (Atlas) SLV-3 with an appropriate interstage a fairing. Aerial recovery via C-130 snatch would hopefully occur near Hawaii.<sup>16</sup>

Also reviewed as a part of this briefing were NASA's low-speed tests at Edwards, and advanced system design studies, including a high L/D study and subsystem studies in guidance and control, communications, heat shield, and instrumentation.

The fourth topic briefed was the data capsule program as envisioned by SSD. A 28-inch SV-5 shape was the capsule and an

80 lb payload was to be recovered. A 600-mile reentry crossrange would be demonstrated from a low-earth orbit, with the vehicle (including payload) weighing a total of 500 lbs. An external reentry rocket deorbit system would be used. The small size of this data capsule vehicle necessitated some development work in subsystems such as guidance and control, environmental control, flap actuation, thermal protection, and communications. A titanium structure was required and manufacturing techniques would be difficult and expensive. Two phases in the flight test program were defined: spacecraft demonstration followed by system demonstration. The spacecraft demonstration called for four flights on an SLV-3 booster with recovery in the Kwajalein area and terminal guidance from near by Roi Namur. Two flights would terminate with water recovery of a data "bucket." The system demonstration would employ two flights on a Thrust Augmented Thor (TAT)-Agena from Vandenberg into polar orbit. Air recovery of a data bucket would be accomplished on the eighteenth orbit near Hawaii using Hawaii terminal guidance facilities.

The fifth part of the briefing described the Maneuverable Ballistic Reentry Vehicle (MBRV) program that was being conducted by the Ballistic Systems Division (BSD). Its program objectives were compared with those of the proposed START data capsule program. The sixth part of the briefing also compared the START data capsule with other data research vehicles, but in a much broader sense. Boost Glide Reentry Vehicle (BGRV), Discoverer, Blunt MBRV, ASSET and the Scaled MBRV were compared.

The last topic briefed was a proposed SV-5 ferry craft. The vehicle size proposed for flight test was the 120-inch wide type and weighed about 11,000 lbs including 4 men, ballast, and cargo to be launched aboard a Titan IIIC on 3/4 orbital flight from the Cape. Recovery would be near Hawaii.

AFSC staff briefings followed on the morning of October 15. Lieutenant Colonel Earl McCabe, START's project officer at AFSC

headquarters, arranged to have General Ritland hear the briefing in the afternoon of that same day. General Ritland was strongly in favor of the 48-inch vehicle and the technology approach afforded by that size vehicle. On the morning of October 16 the briefing team, then joined by Mr. A. F. Donovan and Dr. Greenberg of Aerospace Corporation, briefed Drs. Flax and Hall, General J. Ferguson, General R. D. Curtin, Colonel C. L. Battle, and Dr. Sutton. At 1 p.m. the briefing was given to Dr. Fubini with Dr. Flax again in attendance. Based on the questions and comments by Dr. Fubini, it appeared that the following significant points were understood and accepted by him: (a) the need for firm and clear program objectives, (b) the need for release of the remaining FY65 funds, (c) the value of aerial recovery of a vehicle, (d) the value of the technical data and the need for instrumenting the heat shield, (e) flights from Vandenberg would provide a good simulation, and (f) that the Air Force recommended the 48-inch vehicle as first preference but that the smaller vehicle would be acceptable if so directed. Dr. Flax indicated after the meeting that he would meet with Dr. Fubini on October 17 or 19 to reach some agreements on future actions.<sup>17</sup>

On October 24, 1964, Dr. Flax sent a memorandum up to DDR&E in response to Dr. Brown's August 27 memorandum. This memorandum set forth a clear status of the START program and the alternatives that seemed to exist regarding its objectives and direction. Dr. Flax's memo is quoted in full below and was subject "START Program:"<sup>18</sup>

This is in reply to your memorandum of August 27, 1964 to the Under Secretary of the Air Force on the above subject, and also deals with questions raised in subsequent discussions with members of your staff relative to this memorandum.

The Air Force efforts in the START Program prior to September 1st were conducted in accordance with the approach described in my memorandum to you of

June 5, 1964, subject: Release of Funds for M-103 Project. The main objective of this Program was the expansion of our knowledge in the field of lifting reentry vehicle technology. This objective had been included, usually as primary, in all DDR&E guidance relative to the START Program up to that time. The flight test program was primarily designed to obtain, by flight test, basic aerodynamic, materials and other technical data pertinent to the technology of lifting reentry vehicles which could not be obtained in ground test facilities with a reasonable degree of confidence in its validity. Such data, when correlated with analytical and ground test results would provide a broad technology base for design of specific vehicles ranging from small data capsules to manned ferry vehicles. The program did not, however, contemplate a flight demonstration of specific engineering prototypes of any particular operational vehicle. The planned vehicle, which had a 48-inch base dimension, was considerably heavier than a minimum weight vehicle which would be desired for a specific operational use in this size range. This approach permitted comfortable safety margins for stress, heat shield ablation and internal heating and allowed us to use existing non-optimized subsystems, while at the same time retaining ample space and weight allowances for sufficient instrumentation and telemetry to derive a large amount of basic information from each flight. The results of this 48-inch vehicle test program would therefore give us information for design of a wide range of lifting reentry vehicles having specific applications. The specific vehicle configuration chosen for the program was the SV-5. This was done for two reasons: first, the fact that a large amount of aerodynamic and heat shield investigation had already been done on this shape under the M-103 program and second, the fact that this vehicle configuration had been specifically designed and developed to provide transonic and subsonic characteristics for a horizontal landing such as would be appropriate to a manned ferry vehicle. Thus, by coupling the results of the START hypersonic tests with subsonic and transonic tests of the same configuration, a first approach to a manned ferry vehicle development would be obtained.

The specific new areas of technology which were to be explored in this program related to heat shields which are subjected to long-time heating in an aerodynamically complex (three dimensional, non-axially symmetric) flow environment. The heat shield for this vehicle would be subjected to heating over a period of 800-1200 seconds as compared to typical figures of 30 seconds for ballistic reentry vehicles and 300 seconds (at a substantially



lower heating rate and a total heat pulse an order of magnitude lower) for orbital decay vehicles. The general character of the heating time history provided in the proposed test program would be not greatly different from that of either a data capsule or a manned reentry vehicle and could be varied by shaping the flight test trajectories. The heating rate itself is a function of vehicle size, the maximum heating rate being determined by the radius of the curvature of the nose. A 28-inch vehicle, for example, would experience nose heating rates of about 40 percent greater than the 48-inch vehicle. Available data on transition from laminar to turbulent flow indicates, however, that the boundary layer would be laminar over most of both vehicles for most of the period of heating (97-99 percent of the total heat pulse). Therefore, correlation of theory with flight data on the 48-inch vehicle should provide an adequate basis for scaling downward.

Naturally, however, a generalized test vehicle would not provide specific engineering information or feasibility demonstration for a specific vehicle of a different size as well as a vehicle of the specific size. In order to obtain engineering (as opposed to basic technological) information, moreover, it is necessary that the detailed heat shield, insulation and structural configurations be embodied in the test vehicle.

Following your memorandum of August 27, we have investigated program alternatives which would provide primarily for flight test of a data capsule of a size and configuration appropriate to lifting reentry of an 80 lb payload. A number of alternative configurations were considered, but time permitted detailed technical exploration of only two. The first was a scaled-down SV-5 shape (modified to simplify the structure and enlarge the volume by fairing over the aft end of the upper surface) and the second was a derivative of the sphere-cone combination being used for the maneuvering ballistic reentry vehicle (MBRV) which has a hypersonic lift to drag ratio comparable to the SV-5. Analysis showed that the modified SV-5 with a 28-inch base width could be designed to return an 80 lb payload at a gross weight in the 500 lb range. The criticality of the gross weight to payload relationship for this kind of vehicle is illustrated by the fact that with 350 lbs weight and 25-inch base width the vehicle would have virtually no payload capability. In order to meet the gross weight of 500 lbs, it was necessary to replace the aluminum structure with titanium and to utilize water wicking for internal cooling so that

minimum heat shield thicknesses and insulation provisions could be used. Also, recovery parachute provisions for air recovery had to be held to a minimum so that only the 80 lb capsule bucket could be air recovered rather than the entire vehicle. The modified MBRV design with an aluminum structure and without water wick cooling (but with perhaps some degree of risk in the proposed method of environmental control) led to a gross weight of 510 to 550 lbs at 32-inch base diameter for an 80 lb payload capacity. Again, recovery would be limited to the data bucket rather than the recovery vehicle.

Cost comparisons of the two data capsule designs indicated that the modified MBRV might be as much as 20 percent cheaper than the modified SV-5, but the cost data have not been refined and it is the belief of SSD that this difference in cost might be greatly reduced if not eliminated in a more refined cost analysis. In view of the interest of the SV-5 shape as a possible ferry vehicle configuration, it would be considered desirable to conduct the program with the modified SV-5 even if the 500 lb data capsule is the objective. It must be kept in mind, however, that if, in a later program, large numbers of high lift-to-drag ratio data recovery capsules were to be procured, the entire matter of capsule cost would have to be reconsidered in choosing the ultimate shape and other design features including subsystems. The data of general technological value on ablating heat shields subjected to the history appropriate to lifting reentry would not differ greatly between the two vehicles.

Because of the need for greater engineering refinement and the use of more complex structural design and environmental control techniques, the 28-inch data capsule program, based on the modified SV-5 shape, would be more costly than the previously planned 48-inch SV-5 program. It is estimated that a cost increase of approximately \$7.5 million would be involved in going from the 48-inch SV-5 program to the 28-inch modified SV-5 program. The data capsule program would provide a flight demonstration of the specific vehicle chosen and would verify the engineering design of heat shield, structure, flight controls and environmental control. All safety margins would be reduced to ordinary engineering limits in order to achieve operationally suitable capsule weights, thereby increasing the program risks which must be met in development of a vehicle for a relatively unexplored regime of flight. The basic technology data which could be obtained with the 28-inch vehicle would be substantially lower than with a 48-inch vehicle (186 data points versus 394) and the reduced size would generally

make instrumentation more difficult. Further, for the 48-inch vehicle a larger parachute could be carried, permitting air recovery of the entire vehicle with subsequent inspection and analysis of structure and heat shield; the 28-inch vehicle would require water recovery with resulting damage and alteration of these components.

We believe that, as compared to the alternative program based on the 28-inch modified SV-5, the previously planned 48-inch SV-5 flight test START Program would be lower in cost and vehicle development risks, and would be far more productive of basic scientific and technological data on lifting reentry vehicles, including data capsules down to 28-inch size. There is no significant difference in the planned development schedules for the two programs, although the greater engineering risks inherent in the smaller vehicle may cause program delays which cannot now be foreseen. We recommend a program based on the 48-inch SV-5 vehicle, as described in the attached TDP, which was prepared prior to your memorandum of August 27, 1964. In the event, however, that you feel that there is a high probability that there will be a specific near-term application of the 28-inch data capsule and desire that the START Program be primarily directed toward flight demonstration of an engineering prototype, we have briefed your staff on our preliminary plan for this alternative program. A briefing summary including the technical plan, estimated costs and schedules for the alternative program is attached. This summary also provides the information you requested in support of any Air Force proposal which might recommend a vehicle larger than a data capsule prototype. The principal factors favoring a technology program based on the 48-inch vehicle are, however, those which have been discussed herein.

Regardless of the specific hypersonic flight test scale which is chosen, we propose to continue to include in the START Program studies and analyses along with subsonic and transonic experiments relevant to the technology and configuration development of manned ferry vehicles with lifting reentry capability, as described in the attached TDP.

DDR&E responded quickly to this memorandum. On November 2 Dr. Brown signed a memorandum to Dr. Flax giving firm direction for START. The memorandum is quoted, in part, below and the "Reference A" mentioned in the memorandum refers to Dr. Flax's memorandum quoted above:19

I understand your memorandum, Reference (a), to recommend the 48-inch SV-5 vehicle if the OSD interest is primarily in technology and the smaller SV-5 vehicle if the interest is primarily in a maneuverable precision-recovery data-return development. I also understand from staff discussions between DDR&E and the Air Force that, while the 48-inch vehicle could be instrumented much better, a reasonable amount of instrumentation for technology purposes can be carried in the smaller size, and in any case its recovery and laboratory examination should be a part of the program and could have broad significance. Your assessment of the conical shape shows it to be adaptable to the data return system, but much less useful from the technology standpoint.

Therefore, the Air Force is requested, in proceeding with the START Program, to establish as its primary objective the development and test of a maneuverable data-return capsule of recovering 80 lbs of payload from the low-earth orbit. I understand the development will be based upon the SV-5 shape having the general characteristics described in your memorandum, Reference (a), and its attached briefing summary.

My judgment is based upon the following: There is a foreseeable need that could be important for a data capsule, the return trajectory of which has considerable independence from the orbit of the parent satellite. The objective of the START Program should be to demonstrate the effectiveness of a system which can travel cross-range about 700 n.mi. or approximately half the distance between orbital traces of a low-altitude satellite. In addition, the impact accuracy to be demonstrated should be sufficient to allow the capsule to be recovered within the boundaries of any of several large military installations. A CEP of less than 10 n.mi. should be consistent with this requirement. The payload to be recovered, 80 lbs, should be taken as a design point, but viewed in the sense that it is not expected to increase, but a somewhat lower figure (perhaps 40 lbs) should still be useful.

The Technical Development Plan attached to Reference (a) is, of course, based upon earlier consideration of a 48-inch vehicle and will need revision to fit the development of the smaller vehicle appropriate to the data capsule design. Pending a revision of the TDP laying out a definitive development approach, cost and schedule, the release is being made by separate document of \$16.4 million in deferred FY65 funds for the purpose of accelerating the existing program to the desired rate

of progress. In submitting the revised TDP, we request your recommendation on merits of recovering all the flight vehicles for technology purposes in addition to recovering data capsules.

I concur in your proposal, expressed in Reference (a) to include studies, analyses and low-speed testing relative to the development of manned ferry vehicles. Your plans for this work should be included in the revised TDP.

Harold Brown's preference for the smaller data return vehicle vs. a larger and more research-oriented SV-5 won out. The 48-inch SV-5 was gone. In its place was the smaller (and more difficult to develop) version. With firm direction at last for the START Program, a Program Review Meeting was called and held at the Martin Company on November 18-20. Representatives from SSD, Aerospace, Martin and General Dynamics were present. Specific attention was devoted to the details of vehicle size and configuration to meet the new program objectives. Another important issue was the word changes required in the work statement of the existing letter contract with Martin. The changes required were sufficiently minor in nature so that there was no problem in continuing the existing contract. Had these changes been major, another Determination and Finding (D&F) would have been required and very nearly the whole formal program approval cycle would have had to have been reaccomplished. Some very significant technical decisions were also made regarding hardware to be flown on this lifting body: a strapdown guidance system would be used, a single chute recovery system plus a drogue device, a new water wicking environmental control system, UHF used for terminal guidance commands, VHF telemetry without X-band back-up (in contrast to ASSET), and hydraulic actuators for flaps.<sup>20</sup>

The program really began to take shape in November. Colonel Scoville (promoted in mid-November) began receiving additional staff for the program office. The office now consisted of 12 officers: Major John Pearce, Major G. S. Lewis, Captain Robert Gerzine, Captain Charles Gentzel, Captain Ken Hughey, Captain James Espey, Squadron Leader E. A. Bernard (RCAF), Captain A. H. Davidson, Captain George Henning, Lieutenant John Dobby, and Lieutenant Don Hinton. Mr. Art Kimberly was also assigned to the office as an Air Force representative from Wright-Patterson AFB. The Aerospace Corporation's support consisted of approximately 25 technical staff.

An AFSC Program Guidance Release was issued on November 30, 1964. It contained the following guidance: (underlining indicates emphasis added by editor)

Primary Objective of program is now defined as the development and test of a maneuverable data return vehicle capable of recovering 80 pounds of payload from low-earth orbit with a CEP of less than 10 n.mi. Previous objectives are retained but relegated to secondary position.

You are authorized to proceed with the following elements of the Program as described in your October 16 briefing and modified hereby: (a) Development and flight test of an SV-5 vehicle with characteristics as required to not only satisfy the primary objective but also provide as much information as possible in support of the other objectives. Size of the vehicle is not specified but will be determined by the referenced payload recovery capability coupled with considerations of low technical risk, limited development requirements, and related cost factors. (b) Alternate configuration analyses, advanced design studies and low-speed testing relative to the development of manned ferry vehicles except that all work statements for contractual effort in the analysis and study areas will be reviewed and approved by this Hqs prior to RFP releases. The rationale for all of these projects as well as their scope and content should be reexamined in the light of the modified objectives of the program and the lack of SAF-RD approval of the three space study proposals: Operational potential of high L/D, economics of recovery, and manned maneuverable ferry

vehicles. Request revision of the August 64 Technical Development Plan as necessary to reflect objectives of the Program as now defined and to convert your present plans from development of a 48 inch technology vehicle to development of a smaller vehicle appropriate to the data capsule objective specified by DDR&E. The revised and fully coordinated TDP should be available to this Hqs by January 15, 1965. It will be expected to provide definitive information concerning your development and test approach, funding requirements, schedules and program management plans.

Action is being taken to release deferred FY65 START funds in the amount of \$16.4 million for application to all elements of the Program except ASSET. These funds may be used as you see fit to accelerate the present rate of effort but you are advised that no additional FY65 funds will be made available to this end. As for any ASSET costs over and above the \$5.0 million of FY65 funds already released, these will have to be covered by reprogramming actions of either Hqs AFSC or Hqs USAF.

It is emphasized that the SV-5 hypersonic test vehicle is not to be designed as an operational prototype data capsule but rather as an engineering feasibility prototype. Within the constraints of prototype size and weight appropriate to an 80 lb payload vehicle (approximately 500 lbs desired), Program should be designed to yield as much basic technological data as possible on lifting reentry vehicles in general. Flight demonstrations should simulate data recovery vehicle's critical aerothermodynamic and dynamic parameters. Special consideration should be given to size and design features which will allow air recovery of the entire SV-5 vehicle so as to permit post-flight inspection and analysis of structures and heat shields unaffected by recovery conditions or operations. Discussion of the merits and feasibility of recovering all of the flight test vehicles as well as the payload data packages should be documented as part of the revised TDP. It should also be kept in mind that "coupling" of the hypersonic and low speed flight tests is still of interest; your planning should therefore include consideration of both a powered and unpowered SV-5 subsonic/transonic drop test vehicle program. The technical desirability, practicability and cost of a "Boilerplate" SV-5 flight as part of the Titan III R&D Program should also be explored.

Additional direction authorized the program office to proceed with low-speed wind tunnel tests in support of the low-speed project even though the work statement had yet to be approved by Air Force headquarters. The TDP included several low-speed alternatives: a transonic drop test vehicle rocket powered for flight to Mach 2 and about 100,000 feet; a subsonic, turbo-jet powered vehicle capable of unassisted take-off, climb to about 20,000 feet, descent and power-on landing (touch-and-go), with the capability to repeat the maneuver and to accept wave-off and go-around on the second landing; and finally, a vehicle capable of being either rocket or turbo-jet powered to perform either the transonic or subsonic mission. The "boilerplate" SV-5 flight was to be shown as a separate part of the TDP.<sup>21</sup>\*

So we see, in summary, that the START program office effort was divided somewhat into five areas: hypersonic flights, low-speed flights (full-scale), studies, boilerplate, and ASSET. The hypersonic flight test program received a name at this time. It was termed PRIME for Precision Recovery Including Maneuvering Entry. The low-speed project was henceforth referred to as PILOT, for Piloted Low-speed Tests. The PRIME spacecraft was designated the SV-5D; the PILOT vehicle was designated the SV-5P and subsequently, the X-24A, and is discussed within the lifting body study.

The work pace reached an intense level in the START office during December 1964. A draft of the Technical Development Plan (TDP) was prepared by Christmas and distributed for coordination. The final version was due at AFSC by January 26, 1965. The Request for Proposal (RFP) for the Martin Company had to be prepared and the target date for submission to Martin was January 8, 1965. The work statement for the Alternate

---

\*This so-called "boilerplate" test article was later dropped from consideration.



Configuration Study was prepared and sent to AFSC on December 23. General Dynamics was put on-board as the launch systems integrating contractor and a work statement was prepared for this effort. Four SLV-3 Atlas boosters were ordered, the first for a November 22, 1966 launch. The SV-5 boilerplate flight on the Titan IIIC was defined with the Martin Company and a proposal was prepared. Wind tunnel time was requested at NASA's Langley Research Center for transonic force, pressure, and hinge moment tests, for C-130 recovery tests, and for B-52/SV-5 separation tests. Supersonic force, pressure and hinge moment tests were also requested at NASA's Ames Research Center. General Funk was briefed on December 18 on various procurement alternatives for the PILOT project. Although he assured the briefers that the SV-5 would be tested in the low-speed regime, the best method of procurement was not obvious. General Funk was also briefed on the boilerplate flight and was surprised at the initial cost estimates that then were reworked with an eye toward cost reduction items. Another activity of importance at this time was defense of the requirement for Member Technical Staff (MTS) support from Aerospace. The office had been asked to analyze the situation to determine if 25 MTS would be sufficient rather than the 40 MTS requested.<sup>22</sup> The problem was worked and alternatives such as having Martin do the GSE and TD (General System Engineering and Technical Direction) or contracting to an independent contractor or having it done by Wright Field were considered. Having Aerospace supply 25 MTS was found most acceptable but not really considered sufficient. The ASSET project also created its own amount of work since a launch was scheduled for late February and a study on the possible re-flight of ASV-3 was nearing completion with a briefing being prepared.<sup>23</sup>

Early contact was being made at this time with the Western Test Range (WTR) in order to acquaint the 6595th Aerospace Test Wing (ATW) with the PRIME project and its support requirements.

This early meeting with the Test Wing was later realized to be an important step in gaining timely and needed support from the Western Test Range (WTR) for the PRIME project. On December 7, Colonels Keefer and Scoville and Messrs. Moss and Ashmore of Aerospace visited Vandenberg AFB. The purpose was to brief Vandenberg personnel on PRIME and to obtain information required by SSD to write the TDP. A secondary purpose was to obtain guidance on how the SSD program office would interface with the many range agencies needed to support PRIME. Colonel Preston C. Newton, Commander of the 6595th ATW and Colonel Roy H. Worthington, Deputy for Space, were present for the briefing. Program Office personnel came home with a fair idea of what was to be expected in the line of range support. The set-up with the 6595th was fairly easy to grasp since they were a part of SSD. However, establishing an effective working set-up with the WTR, the Advanced Research Projects Agency, the Army Missile Command, and the recovery forces in Hawaii was going to be a difficult and thought-provoking task. The 6595th ATW did not show any early interest in being the single point of contact with these other support agencies so the job was given to the START Program Test Operations Branch headed by Captain Gerzine. There were two other branches in the office. The Engineering Branch was headed by Major Lewis and the Program Control Branch by Major Pearce. Major Pearce acted for Colonel Scoville in his absence.<sup>24</sup>

The Boilerplate Project, eventually canceled, consisted of a large scale SV-5 configuration flown on a Titan IIIC and the project's life was based on the near term requirement for manned ferrycraft development. There were several questions yet to be answered regarding ascent environment. One question, for example, was whether or not it was most optimum weight-wise to shroud the lifting spacecraft or to beef up the booster structure so as to withstand the aerodynamic bending loads during ascent. The boilerplate project was to acquire data on aerodynamic pressure distributions, heating distributions, accelerations, buffet and

vibration environment, and correlation of wind tunnel data on a large scale vehicle. Exposure of the new ablative heat shield during ascent would provide valuable information. Also, the Titan IIIC, or growth versions, would most likely be the booster for future manned ferrycraft missions so the compatibility of the booster and payload could be checked at an early date. The SV-5 boilerplate was to weigh 21,000 lbs and would not be recovered. About 157 instruments were planned including accelerometers, microphones, vibration pick-ups, pressure sensors, and thermocouples. The vehicle would be placed in a low-earth orbit and oriented by a transtage. About four orbits were planned. The total estimated cost was \$1.6 million. On January 20, General Funk signed a letter to General Schriever requesting immediate approval of the Boilerplate Project and a release of \$1.1 million for FY65. The launch would occur in the fall of 1965.<sup>25</sup>

On January 29, the START Program Development Plan was forwarded to AFSC headquarters via a cover letter to General Schriever. This was done in accordance with the request by AFSC in their November 30, 1964 Program Guidance Release. The program, as approved and described in the development plan, consisted of the PRIME project, the PILOT project, the Configuration and Advanced System Design Studies, and the ASSET project. All of the effort in the plan was approved except the studies. Dr. Flax had requested review and approval of the studies package prior to release to industry in an RFP. Three possible additions to the development plan were being considered at the time. These were: (a) the Boilerplate project, (b) a second procured vehicle for the PILOT project, and (c) reflight of the ASSET project's ASV-3. These were included in the plan as submitted.<sup>26</sup>

Regarding the studies, the proposed work statement for the Alternate Configuration Study was submitted to AFSC headquarters

on December 24, 1964. SSD had since then been advised that Dr. Flax desired that the total proposed study effort be submitted in a single package. To this end, effort was directed to prepare such a package containing work statements for the following studies: (a) Advanced Heat Shield/Structure, (b) High L/D and Variable Geometry, (c) Instrumentation Subsystem, (d) Communications Subsystem, and the (e) Guidance and Control Subsystem.

The objective of the PRIME project in this development plan was "to develop and test a maneuverable data return vehicle capable of recovering 80 lbs of payload from low earth orbit with a 3-sigma accuracy of 10 nautical miles radius or less." This primary objective never changed. Recovery was planned in the Kwajalein area after an up-down trajectory from Vandenberg AFB. Four flights were planned on the SLV-3 booster and flight was to terminate at Mach 2.0 at about 100,000 feet. The size of the PRIME vehicle was noted as 34 inches.

The PILOT project was broken into two portions. The "bare-bones" project would procure only one vehicle. An "Extended PILOT project" was proposed which would procure two jet powered vehicles and would offer improved control and flight instrumentation systems on the vehicles.

The following is a cost summary contained in the development plan:

PRIME Project	\$ 60.64M (million)
PILOT Project	1.50M
Studies	3.50M
Aerospace GSE/TD	4.00M
Boilerplate	1.60M
Extended PILOT	<u>2.60M</u>
	\$ 73.84M

Funding by fiscal year for this effort was proposed at \$17.5 million for FY65, \$38.35 million for FY66, \$17.74 million for FY67,

and \$.25 million for FY68. Sixteen officers were requested to man the program office. This included one Colonel, one Lieutenant Colonel, four Majors, seven Captains and three Lieutenants.<sup>27</sup>

Planned PRIME milestones as set forth in this development plan included:

Preliminary Design Review	Apr 1965
Martin contract definitized	Jun 1965
Begin Flight Vehicle fabrication	Jun 1965
Critical Design Review	Oct 1965
First Flight Vehicle complete	Sep 1966
First flight	Nov 1966
Final Report	Dec 1967

PILOT project milestones were to conduct the first glide test in September 1966 and the first powered one in April 1967. All proposed studies were to be complete by August 1966.

On February 10, 1965, General Ritland signed out a letter to SSD which disapproved the Alternate Configuration Study work statement as it was forwarded in late December. AFSC headquarters decided not to send it to Air Force headquarters as written. The problem was that the new study looked very much like the proposed Manned Maneuverable Spacecraft Study which had recently been initiated by SSD but had been disapproved. The request was that duplication be removed and that it lose resemblance of a planning study. The objectives seemed to be too broad for a follow-on study. General Ritland made clear that the Alternate Configuration Study was intended to define a possible follow-on program to START in the event such a program proved to be desirable. As such, the study was supposed to compare the SV-5 with possible competitive vehicle configurations.<sup>28</sup>

The Alternate Configuration Study was also plagued by the fact that NASA-Marshall Space Flight Center was conducting studies

with very similar tasks and study criteria. Even the study approach was similar -- design for the logistics mission and evaluate for alternate military missions. It was becoming increasingly evident that writing a work statement to justify this study was going to be impossible. One approach was to build on the NASA efforts concentrating on the unique mission differences.<sup>29</sup>

On February 9 the START Development Plan was approved by AFSC and forwarded to Air Force headquarters under General Ritland's signature.<sup>30</sup>

A START Program Review meeting was held in early February. Program status, progress, and plans for the future were discussed and potential problem areas were revealed. The 6555th Aerospace Test Wing (ATW), the 6565th ATW, the 6594th ATW, the Air Force Western Test Range (AFWTR), the National Range Division (NRD), the Martin Company, and General Dynamics were all represented. With regards to the Martin contract, the January spending rate was \$.831 million per month and a June rate of \$2.76 million was projected.<sup>31</sup>

In mid-February a massive proposal was completed by the Martin Company defining the program that was outlined in late 1964 and also the program outlined in the development plan which was then in review by Air Force headquarters. The price tag on the effort described was \$52.8 million. A time consuming task was therefore established for the START Program Office personnel over the next few months. The job was to review in detail the entire proposal, to locate its weak areas, to find where it was fat, to examine the costing technique, to determine whether the project objectives would be accomplished with the proposed work and to finally trim the effort so that the program could be afforded. This job was to consume many extra hours of project personnel before it was to be completed in June.<sup>32</sup>

## NOTES

1. Determinations and Findings, D&F 64-11C-87, Management Report Number P-65-1-680A, dated 8 July 1964.
2. AFSC Management Report, Program Element 63409874, Project 680A, dated 25 March 1964.
3. DD Form 1261, Negotiated Contract AF 04(695)-643, dated 6 August 1965, page 1A.
4. Memo for Record, Lieutenant Colonel C. L. Scoville, Director, Program START, 14 August 1964, subj: Trip to St. Louis and Washington, 10-12 August.
5. Ibid., p. 2.
6. Ibid., p. 2.
7. Ltr, General P. Cooper, Vice Commander, SSD, to General O. J. Ritland, Hq AFSC, 17 August 1964, subj: Program START (680A) Technical Development Plan.
8. Memo, Harold Brown, DDR&E, to Dr. Flax, SAFRD, 27 August 1964, subj: START Program.
9. Memo, Lieutenant Colonel C. L. Scoville, SSTRS, to Colonel N. J. Keefex, SSTR, 28 August 1964, subj: General Schriever/Mr. Bergen Meeting.
10. Minutes of the START Program Review Meeting, 10-12 September 1964.
11. Talking Paper for General Funk, dated 6 October 1964.
12. Memo for Record, Dr. A. F. Donovan, 8 October 1964, subj: Meeting with Dr. Alexander Flax on the START Program.
13. Record of conversation at 25 September 1964 briefing to Dr. Hall on START Program, not dated, known only to be an Aerospace Corporation work.
14. Memo, Dr. Alexander Flax, SAFRD, to Air Force DCS/R&D, 28 September 1964, subj: START Program.
15. Ltr, General B. I. Funk, Commander, SSD to General B. A. Schriever, Commander, AFSC, 9 October 1964, subj: START Program.
16. Briefing, "START/Capsule of Technology/Ferrycraft," 16 October 1964, Aerospace Corporation control number AS64-0000-03884.

17. Formal submittal of information for General Funk's weekly staff meeting, submitted by Lieutenant Colonel Scoville, dated 19 October 1964.
18. Memo, Flax to Brown, 24 October 1964.
19. Memo, Brown to Flax, 2 November 1964.
20. Minutes of START Program Review Meeting, 18-20 November 1964.
21. AFSC Form 56, AFSC Program Guidance Release, Project 680A, 30 November 1964.
22. Ltr, Colonel L. S. Rochte, Deputy for Technology, to Colonel Hamby, Contracts Management Office, 11 December 1964, subj: MTS Support for START.
23. Ltr, Colonel L. S. Rochte, Deputy for Technology, to General B. I. Funk, Commander, SSD, 17 December 1964, subj: MTS Required in Support of START.
24. Memo for Record, Capt R. Gerzine, Chief, Test Operations Branch, 14 December 1964, subj: Trip Report to Vandenberg Air Force Base, 7 December 1964.
25. Memo for Record, Colonel Scoville, Director, Program START, 22 December 1964, subj: SV-5 Boilerplate on Titan III R&D Flight.
26. Ltr, General Funk, Commander, SSD, to General Schriever, Commander, AFSC, 29 January 1965, subj: START Program Development Plan.
27. START Program Development Plan, January 1965.
28. Ltr, General O. J. Ritland, Deputy Commander for Space, Hq AFSC to Colonel C. L. Scoville, Director, Program START, 10 February 1965, subj: START Alternate Configuration Studies.
29. Ibid.
30. Ltr, General O. J. Ritland, Deputy Commander for Space, Hq AFSC to Hq USAF (AFRST), 9 February 1965, subj: START Program Development Plan.
31. Martin PRIME Management Seminar, January 1965.
32. Martin Company, "PRIME (SV-5D) Project, Cost Proposal," Vol III, Part I, Basis for Estimate (ER-13685-III), February 1965.



## CHAPTER III

### DEVELOPMENT

Aerospace vehicle design has always been a battle against inappropriate size and weight, and PRIME was no exception to this general rule. SSD first received notice of DDR&E concern over the size and weight of the PRIME vehicle on March 4, 1965, via a phone call from General E. B. Giller at Air Force headquarters. Giller stated that DDR&E was surprised at the size and weight of the SV-5D since it was greater than that which was decided when DDR&E was briefed in October. Air Force headquarters requested that SSD prepare a paper explaining and justifying the increases in weight. Target date for submittal was March 12, 1965.

On March 10, Dr. Fubini (Deputy Director of DDR&E) signed out a letter to Dr. Flax (Assistant Secretary of the Air Force for R&D) entitled "START Program; Low Speed Flight Test and Hypersonic Vehicle Growth," that read in part as follows:

With reference to the primary objective of your test program, the hypersonic tests culminating in data capsule recovery, I understand that significant changes have occurred in the originally proposed and approved vehicle size. Recently a member of our DDR&E Space office participated with your staff in a review of the program status at the contractor's facility, and it was revealed that the vehicle weight had grown by almost 50 percent; principally to accommodate the recovery of the de-orbit engine and to provide adequate air recovery for the entire vehicle.

In view of our past discussions on the relative priority of capsule return versus vehicle recovery, and since the project is still a limited advanced development program, I would like to understand the reasons for the changes. I tend to believe that test objectives should remain as originally proposed and that the vehicle weight should be constrained to 500 pounds. It may

be that I do not have sufficient appreciation of the reasons that suggested the changes. In this case I would like to be informed.

In addition, please let me know whether it seems feasible technically to allow an appropriately designed de-orbit engine to reenter separately.

Please do not commit the hardware to design freeze until we have had an opportunity to resolve these questions.

Three specific questions were asked by Hq USAF: (1) How and why did the PRIME vehicle grow from 28 to 34 inches? (2) What would be the effect on the START program if directed to return to minimum size? and, (3) What cost savings did the present 34 inch size offer over the miniaturized 28 inch size? An apparent breakdown in understanding in Washington now added its own confusion; on November 28, 1964, Chief of Staff of the Air Force transmitted to AFSC a message on the START Program Reorientation as directed by OSD. It read in part that:

Primary objective of program is now defined as the development and test of a maneuverable data return vehicle capable of recovering 80 pounds of payload from low earth orbit with a CEP of less than 10 nautical miles. Previous objectives are retained but regulated to secondary position.

You are authorized to proceed with the following elements of the program as described in your October 16 briefing and modified hereby: Development and flight test of an SV-5 vehicle with characteristics as required to not only satisfy the primary objectives but also provide as much information as possible in support of the other objectives. Size of vehicle is not specified but will be determined by referenced payload recovery capability coupled with considerations of low technical risk, limited development requirements, and related cost factors.

Special consideration should be given to size and design features which will allow air recovery of the entire SV-5 vehicle so as to permit post-flight inspection and analysis of structures and heat shields unaffected by recovery conditions or operations.

The Development Plan submitted to Headquarters in late January had been updated to reflect these objectives. Two vehicles were described in this document: an SV-5D operational configuration and an SV-5D test configuration. The test configuration size was derived from the operational configuration; however, the weight of the test vehicle was allowed to vary for purpose of obtaining technological data. The operational vehicle size resulted from an extensive evaluation of the direction and guidance provided from higher authority and upon hypothetical operational de-orbit and reentry modes.

SSD forwarded a very comprehensive answer to the three questions asked by Air Force headquarters on March 11, 1965 to Headquarters AFSC. The reasons for the changes in size and weight were very fundamental and important and are worthy of discussion.<sup>1</sup>

The test and operational vehicle size and weight changes that occurred between the time of the original SV-5D configuration definition at the October 16 briefing, and Fubini's query are summarized in Table 2. These changes were determined principally through considerations of various de-orbit system arrangements, the selection of primary structural materials, the enlargement of equipment bays to allow the use of reasonable packing densities, and the selection of the recovery mode of the test vehicle including the selection of items to be recovered. The basic approach in sizing the vehicles was to determine the configuration of the operational vehicle which met the requirements of a particular set of ground rules, and then design a test vehicle within the geometric constraints of that operational vehicle. In all cases the thermal protective system was ablative, making PRIME the first American venture in lifting reentry incorporating an ablative, as apparent to a radiative hot structure, approach to thermal protection.<sup>2</sup>



TABLE 2

SUMMARY SV-5D SIZE AND WEIGHT CHANGES28 to 34 INCHES

	Vehicle Description (Major Changes Listed)	Reference Size (Inches)	Operational W	Weight ΔW	Test W	Weight* ΔW
Basic Concept	(1) Titanium Structure Recovery of payload or instrumenta- tion only No de-orbit system included 80 pound payload 600 mile cross-range	28	511	0	-	-
	(2) Add to (1) External De-orbit System	28	620 **	109	581 **	0
Progressive Refinement	(3) Change from (2) Size increase required due to excessively high packing density and volume utilization	29	642	22	600	19
	(4) Change from (3) Titanium Structure to Aluminum	30	680	38	658	58
	(5) Change (4) to accommodate Air Recovery of Test Vehicle (recommended during October 16 briefing) Operational still air recovery of payload or land impact of payload or total vehicle 700 nautical mile cross- range	33.8	780	100	810	152
Ultimate SV-5D	(6) Change (5) to accommodate internal de-orbit system on operational vehicle	34	810	30	840	30

\* Only operational vehicle had de-orbit system.

\*\* Exceeded packing density and space utilization requirements.

Certain ground rules were basic throughout the development of the SV-5D vehicles. In all configurations of the operational vehicle, the recovery mode was air recovery of the payload; however, that same recovery system could safely deliver the payload by earth impact if the recovery aircraft failed to snatch the parachute, or if other requirements dictated a land recovery. In the sizing of all vehicles, the maximum packing density and space utilizations that were allowed for a reasonable design were 40-pounds-per-cubic-foot and 50 percent respectively. In no case did the test vehicle weight include a de-orbit system.<sup>3</sup>

Table 2, which shows the vehicle change history, includes certain configurations which served as basic points of departure in defining the final configurations. For example, in Table 2, the minimum design operational vehicle for an 80-pound payload, based on maximum packaging density and space utilization limits, would have been a 29-inch titanium vehicle weighing 642 pounds, and would have had an external de-orbit system. This weight included the de-orbit system. In addition, the minimum size test vehicle based also on density and space utilization limits, would have been a 31-inch titanium vehicle weighing 679 pounds, and would have provided the recovery of only the instrumentation package. This vehicle is not shown on the historical summary.<sup>4</sup>

The following few paragraphs describe how these basic configurations evolved to incorporate internal de-orbit in the operational vehicle and total test vehicle recovery, thus culminating in the ultimate SV-5D test and operational vehicle configurations.

Consider first the basic SV-5D (vehicle #1 on Table 2). The original minimum size SV-5D was a 28-inch, 511-pound, titanium substructure operational data return vehicle having the capability for the return of an 80-pound payload, and a 600 nautical mile re-entry cross-range maneuver. The recovery mode was air retrieval of the payload only. The weight of this vehicle did not include a

de-orbit system since the weight goal was considered to be less than 500 pounds at reentry. It was believed at the time of the definition of this vehicle that by means of additional study, 30 pounds of ballast could be removed by reducing the static stability margin, and that 5 pounds of structure and heat shield could be removed by leveling the upper aft end ramp area, thus reducing the gross weight of 476 pounds. However, further aerodynamic analyses and wind tunnel tests showed that neither of these changes could be accomplished because of the understandably adverse impact upon aerodynamic stability and control.<sup>5</sup>

Vehicle #2 was the same as the basic SV-5D described above but with the addition of an external de-orbit system. In the October briefing to DDR&E, briefers had discussed a de-orbit system with a  $\Delta V$  of between 500 and 1600 feet per second (fps) and weighing between 93 and 310 pounds. More detailed studies made after the issuance of the briefing added an external de-orbit system to the basic 28-inch SV-5D, resulted in an operational vehicle gross weight of 620 pounds, based on a desired  $\Delta V$  of 800 fps. A titanium test vehicle weighing 581 pounds was then adapted to this configuration; however, only the instrumentation package could be recovered due to volumetric limitations placed on the recovery system. Both the operational and test vehicles were later shown to have a packing density and space utilization too high to meet the goal of reasonable costs in the START program.<sup>6</sup>

In order to improve packing requirements for an operational vehicle, the basic SV-5D vehicle was increased to 29 inches and used an external de-orbit system. This was vehicle #3. The result was an operational vehicle having a reasonable packing density, weighing 642 pounds, and permitted aerial recovery or earth impact of the payload. This was considered to be the minimum size operational vehicle. A design conversion of this vehicle to a test vehicle resulted in a gross weight of 600 pounds, and

included the capability for aerial recovery of the instrument package only. However, the packing density of this test vehicle was excessive and it was not considered to be a reasonable design.<sup>7</sup>

Vehicle #4 represented a vehicle structure change from titanium to aluminum and resulted in an increase in size and weight of the 29-inch vehicle. The net result was a 30-inch operational vehicle weighing 680 pounds. This configuration had an external de-orbit system and the recovery mode was by aerial retrieval or land impact of the payload. Design conversion of this vehicle defined a test vehicle weighing 658 pounds including the capability for aerial recovery of the instrument package only. The packing density for the test vehicle was considered too excessive for a reasonable design.

The change from titanium to aluminum was made as a result of a detailed parametric study of the effects of titanium, stainless steel, and aluminum on the design of the vehicle. The following four effects with regard to material factors were significant in this study.<sup>8</sup>

1. The ultimate design temperature of the aluminum was 500 degrees F, while that of the steel and titanium was 1000 degrees F. This would require more greater thermal protection for the aluminum than the other two metals.

2. The effects of material physical properties, higher thermal stresses in the titanium and steel than in aluminum, material densities, and buckling factors produced an aluminum primary structure that was lighter than titanium and steel, and a titanium structure that was lighter than steel.

3. Program costs, and

4. Reliability.



Essentially the above effects revealed that in consideration of structural plus heat shield weights, the titanium vehicle was the lighter, the aluminum vehicle was slightly heavier, and the steel vehicle was the heaviest of the three. Since the steel vehicle was the heaviest and no appreciable advantage could be attributed to it, it was eliminated and the choice was between aluminum and titanium. The titanium vehicle would be approximately one-inch smaller in base width than the aluminum vehicle because of the difference in required heat shield thickness, and the titanium vehicle would be approximately 30 pounds lighter. The considerations of cost and reliability, however, were strongly in favor of aluminum. A cost comparison which was made by the Martin Company showed that the use of a titanium structure rather than aluminum would increase the total program cost by about one million dollars. In addition, the higher operating temperature of titanium (800°F to 1000°F) as compared to aluminum (400°F to 500°F) produced more critical conditions in the areas of structure-to-heat shield bond line stability, structural thermal stresses, and equipment cooling. These effects, therefore, produced a higher degree of risk in a total titanium design than in aluminum. Finally, it must be remembered that, at this time, titanium was not a widely used aerospace material and, in fact, it posed numerous fabrication challenges, such as ensuring weld integrity. Indeed, by 1964 only two aerospace vehicles had made extensive use of titanium as a structural element: the Douglas X-3 research aircraft of the early 1950s, and the Lockheed Blackbird family: the A-12, YF-12A, and soon-to-appear SR-71. It was then concluded that in the interest of lower cost and lower risk, that aluminum would be used and that the penalty of 30-pounds and 1-inch growth in width would be accepted.

Vehicle #5 showed the impact on the 30-inch aluminum vehicle of adding aerial recovery of the total test vehicle and utilizing a reasonable packing density of 40 pounds per-cubic-foot. The

resultant configuration was an 810-pound test vehicle having a base width of 33.8 inches. A comparable operational vehicle with an external de-orbit system would have weighed 780 pounds but would have been oversize since a 30-inch 680-pound vehicle was adequate.

One of the major purposes of the START program was to evaluate performance of the vehicle system during reentry. Understanding the behavior of the heat shield material assumed particular importance. The ablative heat shield contributed significantly to the total vehicle weight; therefore, it was important to acquire as much information as possible to ensure an efficient heat shield design.

Evaluation of the thermal protection system's flight performance was to be accomplished by two means: (1) data acquisition via on-board instrumentation, and (2) post-test inspection and analysis. The heat shield material was porous and would degrade if allowed to soak in salt water. Additionally, water quenching would result in severe thermal stress, buckling and general degradation of the hot shield. Air recovery, then, ensured a vastly superior shield specimen for post flight analysis.<sup>9</sup>

The majority of problems associated with heat shield design occurred in areas of "discontinuities:" regions around doors, flaps, joining of two different adjacent materials, local hot spots, and installation of heat shield instrumentation. Unfortunately, flight data was difficult to acquire in these areas. Post test examination would result in reliable information on shield degradation (ablative charring, cracking, and running), depth of degradation zones, surface recession, and structural integrity of bonds, as well as (hopefully few) local failures.

Vehicle #6 included an internal de-orbit system in the operational vehicle. A proposed mission for a SV-5D data return capsule would be the precision return of payload to any number of

land bases in the United States. A brief study was made to determine where debris from an externally mounted de-orbit would impact. The external engine would have to separate from the re-entry vehicle before the RV entered the atmosphere. The debris would fall in Alaska and northern Canada for recovery at Edwards AFB or Hawaii. For other bases east of Edwards the debris pattern would move eastward forming a swath across northern Canada.\* To add flexibility to possible mission usage as well as to eliminate the debris hazard, SSD opted to incorporate a de-orbit engine into the SV-5.10

The result of designing an operational vehicle for air recovery of the payload, using a reasonable packing density and with an internal de-orbit system, was a 780-pound vehicle with a 33.6-inch base width. In defining a test configuration capable of total vehicle recovery, SSD determined that these conditions would dictate a 33.8-inch 810-pound vehicle. The selection of a 34-inch vehicle was therefore based on the above two requirements since:

- (1) each vehicle was in the 34-inch size range,
- (2) each vehicle satisfied the final selection of the design conditions regarding recovery and deorbit as applicable, and
- (3) each vehicle was packaged at a density of 40 pounds-per-cubic-foot with a 50 percent space utilization factor. (Inboard profiles of the 34-inch test and operational vehicles are shown in Figures 12, 13, and 14).

---

\*It is interesting to reflect on these discussions involving a possible debris path across Canada, in light of the furor, years later, over the "danger" posed by such vehicles as Skylab (1979). The casual acceptance in some quarters of reentry debris falling over possibly inhabited areas was a facet of the early space age, and is comparable to the equally naive notions of the early 1950s that population centers would tolerate the routine supersonic operations over land of commercial and military aircraft. Fortunately, PRIME's developer recognized the very real problems errant debris could pose, and took steps to eliminate this prospect.

The ballast compartment and the guidance and electronics compartment were essentially the same for both vehicles. The instrumentation and recovery compartments of the test vehicle were arranged so that they could be converted, by means of minor structural modifications, to the payload, recovery, and propulsion compartments of the operational vehicle. Packaging and space utilization were primary considerations, and the goals of 40 pounds-per-cubic-foot packing density and 50 percent utilization were based on the ASSET vehicle's experience.<sup>11</sup>

Detailed weight statements of the 34-inch operational and test vehicles are given in Table 3. This table shows the gross launch weights of the test and operational vehicles to be 839 and 810 pounds respectively. These values represented the best estimated weights at the time; but as vendor specifications had not been received for all equipment items, the above weights were not considered final. Design studies were continuing for the purpose of making all possible improvements in the preliminary design. Experience revealed these weight estimates to be surprisingly accurate considering the time and circumstances under which they were made. The test vehicle lifted off two and one-half years later at 859 pounds, only 20 pounds more than estimated.

The vehicle subsystem weights differed appreciably between the vehicles in three subsystems: (1) heat shield, (2) communications, and (3) recovery. Designers expected the heat shield of the operational vehicle to be approximately 20 percent lighter than the test vehicle's on the basis of detail improvements resulting from test vehicle post-flight analyses, and improvements in materials and ablative technology expected during the period of the test program. The communications weight allocation would be less for the operational vehicle since it would not require a radio frequency telemetry link. The recovery weight

TABLE 3  
WEIGHT STATEMENT  
SV-5D 34-INCH REFERENCE BASE WIDTH

COMPONENTS	TEST	OPERATIONAL
STRUCTURE	94	94
HEAT SHIELD	265	209
GUIDANCE	41	41
FLAP & ENG. CONTROLS	19	19
COMMUNICATIONS	26	11
ENVIRONMENT CONTROLS	11	10
ELECTRICAL	42	42
REACTION CONTROLS	19	10
RECOVERY		
AIR-ENTIRE VEHICLE	96	
AIR OR LAND - P/L ONLY, OR LAND IMPACT VEHICLE		39
PAYLOAD (INCLUDES CASE)	--	85
TELEMETRY/INSTRUMENTATION	92	--
DESTRUCT	0	0
BALLAST	<u>134</u>	<u>130</u>
GROSS WEIGHT LESS TOTAL INTERNAL DEORBIT SYSTEM	839	690
DEORBIT SYSTEM	<u>-</u>	<u>120</u>
LAUNCH WEIGHT	839 lbs	810 lbs

would be smaller for the operational vehicle than for the test vehicle because only the operational payload would be recovered as compared to air recovery of the total test vehicle. In addition, the operational recovery system was to be capable of returning the operational payload for air retrieval or land impact, and that system could also return the entire operational vehicle to a land impact for payload removal.<sup>12</sup> \*

Should DoD direct development of a smaller 28-inch vehicle, SSD planners directed an 8-month delay and an added \$7 million in cost. This cost included all hardware and schedule effects and assumed redesign of the entire vehicle and subsystems.<sup>13</sup> Redirection, at that time, to a 29.5-inch vehicle with a 40-pound payload utilizing the majority of subsystems selected for the 34-inch design would have resulted in approximately a 3-month program delay and an added cost of approximately \$2-3 million. If an 80-pound payload were considered, cost and schedules would have been the same; however, the vehicle would be 1-inch larger.<sup>14</sup> The money saved by the decision to build a 34-inch rather than a 28-inch vehicle was estimated to be on the order of \$3 million. This was due to increased hardware costs and a 4-month schedule difference to the first launch (the 28-inch requiring more development time).

The question of whether to plan for an internal or external de-orbit system arose during these months of size and weight determinations. A survey was made to determine the state-of-the-art in "frangible" de-orbit engines. The debris problem was a real one and severe restrictions were being placed on programs in this area. The internal system resulted in increased vehicle size and reentry weight. The external system offered debris problems. Also, a considerable development and analytic effort was due if an external de-orbit system were to be used.

---

\*Presuming, naturally, some damage to the exterior of the vehicle.

On March 22, 1965, Dr. Flax was briefed by Colonel Scoville on the weight and size growth of the PRIME vehicle. The briefing reviewed the facts and direction received and the reasons behind the increases in vehicle size and weight. On April 13, Dr. Flax signed out a long memorandum to Dr. Fubini outlining the reasons behind the vehicle growth. He said ". . . the growth is due in part to a misinterpretation by the START Program Office of the guidance provided by DDR&E and my office, and in part to the need to increase the weight of structure, heat shield and other vehicle elements over the October 24, 1964 estimates, as more detailed engineering design and analysis was completed." He also stated that there were two logical alternatives. They were to continue with the 34-inch vehicle with an external de-orbit system and other modifications to reduce weight or to redirect the program to a 28 to 30-inch vehicle, thus returning to the strict primary objective of a maneuvering data capsule capable of returning 40 pounds of payload from low-earth orbit. More details were offered on the two alternatives. The final selection was now left to DDR&E.<sup>15</sup>

Fubini's request to "not commit the hardware to design freeze until we have had an opportunity to resolve these questions" presented a problem and some questions. Was this to mean critical design review (which was to occur in October) or was it his intent that no subcontracts be let to procure equipment until further direction was received? If the latter were true, the time had been reached when a decision must be made or a day-by-day slip in the total schedule would be experienced. In order to clarify this ambiguity, a message was sent to AFSC headquarters requesting clarification. Systems Command responded on April 22. No subcontracts would be let and the Martin effort was confined to that which would be applicable to both the present program and a program redirected to a smaller vehicle.<sup>16</sup>

On April 30, 1965, General Funk signed out a strongly worded request to General Schriever. He asked for vigorous support for approval of the PRIME project as outlined in the January 27 Development Plan, for immediate procurement of a PILOT vehicle through NASA channels at \$1.5 million, and for continued management of both the PRIME and PILOT projects within the START Program Office of the Space Systems Division. If necessary, he said he would be pleased to proceed to AFSC headquarters and conduct a briefing to any detail necessary to convince Flax and Fubini of the justification and reasonableness of the SSD position.<sup>17</sup>

Apparently, this was the force needed, for on May 5, 1965 Fubini, acting on behalf of Harold Brown, signed out the following memorandum for Flax:

Your memorandum of April 13, 1965, Subject: "START Program, Hypersonic Vehicle Growth," providing a description of the manner in which the START hypersonic test vehicle had grown in size and weight over the values presented at the time the program was approved, described two logical configuration choices that might be made now, one based upon a 34-inch size and the other upon a smaller dimension.

In recognition of the extent to which the vehicle design has progressed, and our joint desire to conserve costs on this program, there appears to be no satisfactory alternative to the selection of the 34-inch size (your alternate number one). I ask that you give careful attention to those features which can be incorporated to provide in the operational version the lightest weight, most payload and greatest flexibility.

In accepting the 34-inch version for both test and later operational phases, it is requested that every attempt be made to insure at least 80-pound payload capability for the operational version but without increase in reentry vehicle operational weight (less payload). As proposed in your letter, alternate number one would strive only for 40-pound payload and might be interpreted as permitting substantial relaxation in electronic equipment packing density. Since we hope that the test article equipment design could be usable operationally, and since reduced packing density in the forward equipment compartment must be balanced by extra ballast weight, I



urge that careful attention be given to the maximum practical packing density in this forward equipment bay.

In the course of recent program briefings and discussions, there has been evidence of a trend in activity, associated with changes in design and with technical difficulties, which could be reflected in rising cost. In the absence of a firm cost proposal from the contractor, one suspects that the program may not be accomplished within the current budget estimate.

I request that you undertake an effort to reduce costs including a careful examination of alternative contracting and program management methods. Starting from the date of this memorandum, I suggest that the contractor be held to a fixed level of effort for a period of 30 days, during which time he prepares and presents two proposals for Air Force consideration based upon the approaches described below:

1. Case I - A CPIF\* contract involving separate technical direction and the elements of program management substantially along the lines which I understand you are following now.

2. Case II - A fixed-price contract, perhaps with incentive features, aimed at reducing the statement of work to the minimum essentials in order to obtain lowest possible contract price. A plan of this kind would treat the START program strictly as an Advanced Development effort and would be characterized, in part, by:

a. Exemption from 375 series program management methods.

b. System engineering performance by the contractor. Aerospace Corporation participation would be confined to specified task assignments, plus a small sustaining technical effort with the program for the purpose of remaining current.

c. Application of military specifications and standards only where determined to be most suitable and compatible with economy objectives.

---

\*Cost Plus Incentive Fee.

d. Curtailment in documentation. For example, detail drawings, specifications, Q. C. reports, engineering analysis reports and similar documents would be eliminated as deliverable items. Such information would be presented informally upon request. Brief documents for the record may be needed in some instances to show contract compliance within the limits which define Advanced Development.

e. Simplicity in AGE.

f. Elimination of redundant or avoidable purchases of flight and ground-test hardware. AGE, mockups, simulators and test rigs.

g. Least possible testing and qualification at the component level, with emphasis on complete system qualification and testing.

h. Elimination of formalized contractual exhibits on reliability, configuration control and value engineering.

I am hopeful that a searching review of the kind contemplated will result in a revitalized management effort that will produce sound technical results and formulate a program that can be held within the limits of the budget.

Hence, the problem of vehicle size and weight was resolved; however, a new exercise in cost reduction and contracting methods was about to begin, for, as the memo clearly emphasized, nothing was to stand in the way of generating a vehicle cheaply, expeditiously, and with an absolute minimum of paperwork.

Martin was immediately directed to withhold from subcontracting until the company received further guidance. This action resulted in a program slippage of about 3 weeks and a cost increase to Martin of about \$100,000. Contract negotiations, scheduled for May 20, 1965 were now also deferred pending a determination of the type of contract to be employed. Unfortunately, the subsequent guidance received from AFSC did not clearly explicate who was to receive the requested written report setting forth

alternative contracting and management methods and the price estimates for each. To resolve this dilemma, the START Program Office chose to interpret the guidance as follows: (a) the real objective of the whole exercise was to come up with a program which did not exceed budget limitations and (b) in order to achieve this objective, a good look must be made at both the Cost Plus Incentive Fee (CPIF) and Fixed Price Incentive Fee (FPIF) type of contracting to determine which would result in minimum cost to the government.<sup>18</sup>

A fact finding team of Air Force and Aerospace Corporation members of the START Program Office, plus contracting and price analysis staffers, journeyed to Martin the week of May 17 to take a close look at the Martin proposal and to reach agreement regarding the manpower requirements and related costs. This action hopefully would provide a firm cost estimate for the CPIF contract and permit a valid comparison with the contractor's proposal for a FPIF contract. Team members requested Martin to prepare the latter, since it could then be compared with a CPIF contract as well.

By June 4 it appeared the only restriction on the START Program Office was with regard to contract negotiations. The contract must be definitized as soon as possible, and it was already clear that preparing a FPIF contract for signature would represent a 6-month effort. This would result in a tremendous cost to the existing letter contract. If indeed the objective of this exercise was to keep the program within the funds available, then it would seem that authorization to definitize a CPIF contract would be easy to gain if the negotiated price were consistent with funding constraints. Therefore, SSD launched a major effort to trim the cost of the Martin proposal by scrutinizing each manhour proposed and understanding why it was needed and how it fit into the overall program. Martin proposed a cost of \$52.8 million. This was almost 20 percent more than could be afforded.<sup>19</sup>

General Funk visited Martin during the week the fact finding team visited the plant and seemed convinced that a CPIF contract could be negotiated with Martin which would result in the full accomplishment of the flight objectives of the program and would be within the cost then programmed for that effort. In order to convince him that funding required would not exceed the funds available, certain reductions in the Martin effort had to be made. However, as a ground rule, these reductions were not to interfere in the accomplishment of technical objectives of the program.

Reduction was made in the contractor's effort associated with compliance with the 375 series of manuals. The general intent of this management guide was carefully followed; however, much of the rigor and detail which is required when building an operational system was very judiciously trimmed away. It was decided not to use a general systems specification which would include the SV-5D and the booster under one cover. There was a requirement that the SV-5D could be easily converted into an operational system if the need existed later. There was no assurance, however, that the SLV-3 would be the operational booster. It was decided to implement configuration management using four basic specifications as instruments. One specification would cover the design, development and testing of the SV-5D. A second specification would govern the interface characteristics of the shroud interstage and separation systems which could not be changed by one contractor without affecting the other. The two other specifications would cover the project's Government Furnished Equipment (GFE) and the command buffer needed in the terminal area. Specification maintenance was to be conducted in general accordance with AFSCM 375 and all specifications would be controlled by one Configuration Control Board in the START Program Office.

In order to further reduce cost, Class I changes were to be those changes which effected contract price or schedule. Changes to Contract End Item Specifications of any type would require Air

Force approval, but a simplified format was planned in lieu of an Engineering Change Proposal (ECP) as defined in AFSCM 375. In this manner, the Air Force would be able to control performance, schedule, and cost changes to the end items and yet provide ample flexibility in the design of the SV-5D.

A related reduction in scope, while not directly associated with the 375 series, was a reduction in the magnitude of the PERT requirements to the minimum which both contractor and the Air Force believe was required for management control purposes. Contract incentive provisions were simplified enabling a reduction in the contractor's effort to monitor the incentive.

The possibility of having systems engineering and systems integration accomplished by the contractor instead of Aerospace was considered. Both Martin and the Air Force believed that it would be inadvisable from the government's point of view to revise the already established relationship between the contractor for the reentry vehicle, the booster contractor, the WTR, VAFB and the recovery groups. Moreover, the elimination of the Aerospace from the role which they were executing would have left SSD without adequate technical support to effectively direct the efforts of the contractor.

Immediate action was taken to reduce the applicability of military specifications and standards to the point where only those requirements would be placed on the contractor which affected gross performance, safety, or interface with associate contractors, the range, or recovery activities. All requirements for formal documentation of Aerospace Ground Equipment (AGE) hardware were deleted. Government approval of qualification test reports and documentation requirements with respect to same were reduced. A major reduction in the DD 1423 requirements was made which permitted the contractor to eliminate a major portion of his editorial and publication cost associated with the program. The

contractor's internal reports prepared to his own format would satisfy the needs of the Air Force for data. All formal report requirements which would simply duplicate reports normally prepared by the contractor for internal use would be eliminated.

The requirement for deliverable AGE was eliminated. This permitted the contractor to implement an informal drawing release system and eliminated a substantial portion of manufacturing, tooling, and engineering cost normally associated with the ground equipment.

The number of test articles were reduced. One set of AGE was eliminated by implementing a factory-to-pad concept. Also eliminated was the fabrication of several items of ground equipment which, after a more detailed search, were acquired through government stock. Qualification test requirements were eyed with a view toward reducing requirements, and hence program cost, without increasing technical performance risks. Formal reliability program requirements were reduced so as to achieve a significant cost reduction without degrading the true reliability of the hardware. Formal logistic support requirements were reduced along with formal test procedure requirements, except where required to demonstrate facility, or booster interface capability.

Martin considered it impossible to prepare a meaningful fixed-price proposal by the end of May. Martin also indicated that in view of the fruitful results in reducing contract scope and cost, and because of the delay and additional expenses that would be occasioned by the establishment of a statement of work and firm cost estimates for a fixed price proposal, a fixed price contract would be more costly to the government than the CPIF envisioned by the existing letter contract. Consequently, it seemed that the best interests of the government would be served with immediate negotiations of the definitive CPIF contract.

Therefore, on May 21, 1965, General Funk signed a message out to General Schriever requesting authority to: (a) immediately

negotiate to definitize the current letter contract, and (b) defer any further effort toward or consideration of a FPIF contract. On May 24, 1965 authorization was received to negotiate a CPIF contract with Martin and to accomplish internal processing and review. The price was to be such that total program costs would not exceed \$16.4 million for FY65, \$35.0 million for FY66, \$10.0 million for FY67, and \$10.0 million for FY68.<sup>20</sup>

Contract negotiations with Martin were completed on June 18, 1965. A CPIF contract was negotiated with a target cost of \$38.7 million, target fee (8 percent) \$3.096 million, for a total price of \$41.796 million which was within the budget constraints set. The contract included incentive provisions on cost (+3 percent) and performance (+3 percent) which allowed a maximum incentive of 6 percent above target fee and a maximum of 6 percent below target fee.

The initial plan to use Roi Namur as a terminal guidance site was developed in the fall of 1964 in response to a DDR&E memorandum requesting examination of alternatives to the 48-inch SV-5 program. The SV-5 program development plan of August 1964 utilized the launch facilities at the Air Force Eastern Test Range (AFETR). As a result of the requested evaluation and subsequent program redirection, the flight test program was transferred to Air Force Western Test Range (AFWTR) and proposed the use of the Pacific Range Electromagnetic Signature Studies (PRESS) Complex at Roi Namur for a terminal site. Program Office personnel, on October 21, 1964, informally briefed AFWTR's Advanced Plans Division, Range Safety Section and Instrumentation Section on the anticipated changes to the program. On December 7, 1964 Colonel Keefer, Colonel Scoville, their staff and Aerospace personnel formally briefed AFWTR and the 6595th Aerospace Test Wing (ATW) on the redirected START program. It was indicated at this meeting that the Martin Company was on contract, and design of the vehicle

was proceeding using Roi Namur as the planned terminal guidance site. Copies of the PRIME Planning Estimate, which had been submitted to National Range Division (NRD) on December 3, 1964, were distributed for AFWTR information and planning purposes. Colonel Dodds, NRD (NRGW), attended this meeting and authorized direct communication between the Program Office and AFWTR to expedite the interchange of information at the working level.<sup>21</sup>

SSD designated the Roi Namur terminal site as Plan A. PRESS, at Roi Namur, was an existing facility and was ideally suited for the PRIME project. The PRESS computer, and IBM 7094, was the same as the contractor's and would eliminate computer and programing costs that would be involved if the computer were not of the same IBM 7090 series. The Roi Namur site, when augmented with some additional equipment was fully capable of performing the terminal site mission. The use of a known fixed installation as compared to the scheduling uncertainty involved in the use of a ship installation or a planned but nonexistent land installation was a significant factor. The PRIME project was an austere effort which was committed to minimizing costs by using existing facilities where possible, while still achieving a high probability of success. The PRESS complex was well established, manned by highly skilled personnel, and experienced on missions as complex as PRIME's. The Program Office's confidence of achieving mission success, if the PRESS complex could be made available for tracking the PRIME vehicle and providing data for terminal guidance, was high. The Army Material Command (AMC) had informally indicated they could support Plan A. Plan A represented the minimum cost to the Program Office, since it involved no redirection of the contractor, and probably represented total minimum cost to the government. The added management complexity which would result from the additional agencies was a recognized disadvantage of this approach.<sup>22</sup>

Figure 8 shows a typical PRIME mission and its support. The range safety aspects of flying past the northern tip of Roi Namur



TYPICAL PRIME MISSION AND SUPPORT

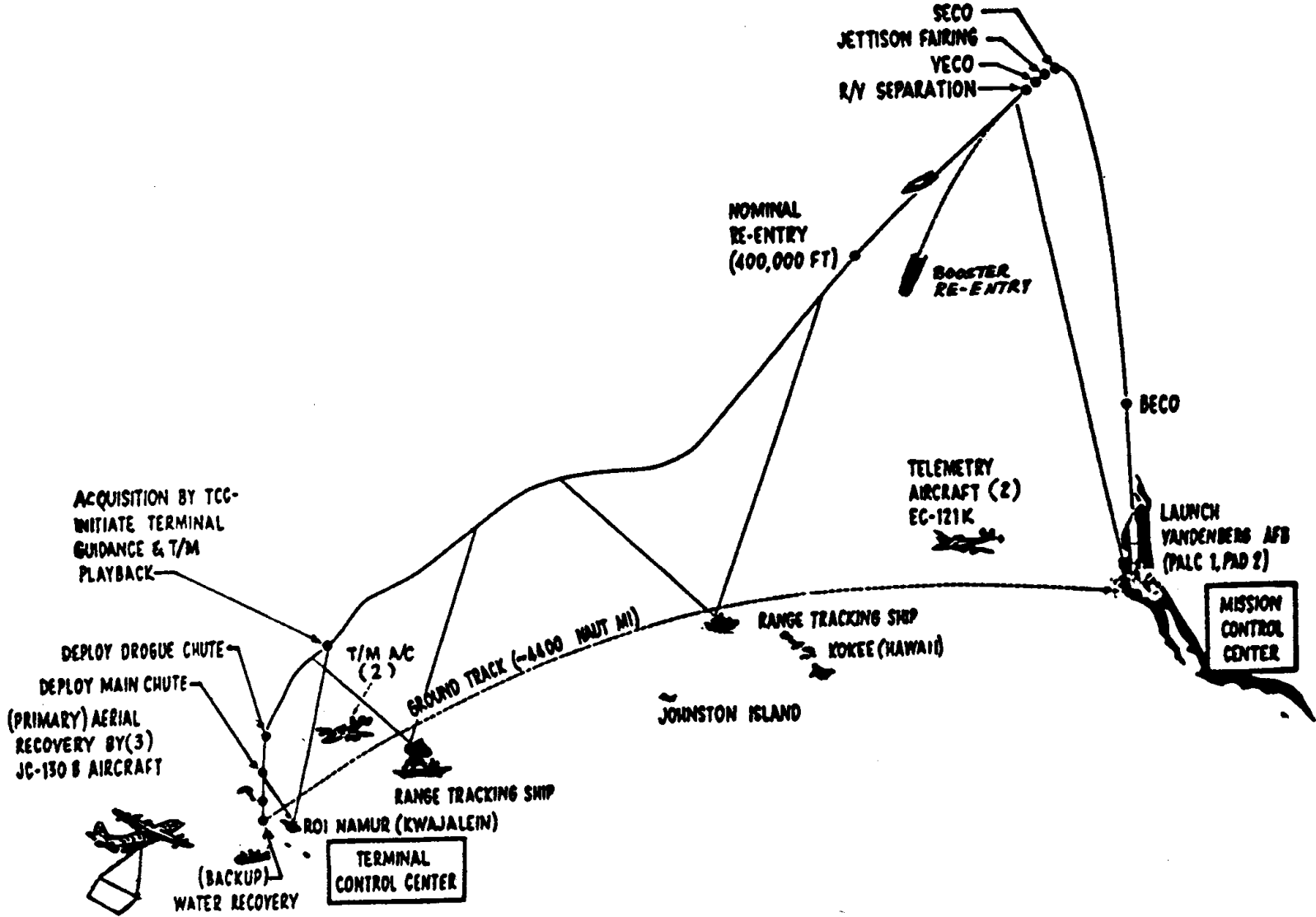


Figure 8

had been under careful investigation by the Program Office. It was generally felt that this aspect of the flight was less risky than those of other programs flying directly into the lagoon between Kwajalein Island and Roi Namur Island. The preliminary results of the range safety study prepared by the Martin Company, utilizing population density figures furnished by AFWTR, indicated a probability of kill in the order  $10^{-9}$ . This did not include any inherent safety benefits derived as a result of the PRIME vehicle having terminal guidance or utilizing a parachute for recovery. A final range safety analysis was to be completed about mid-April.<sup>23</sup>

The START Program Office also considered two alternates for a terminal guidance support site. Plans B and C, as they were called, appeared adequate on a technical basis and AFWTR had indicated that the two alternates could be supported without cost to the program office. The major consideration then remaining unresolved regarding Eniwetok as a terminal guidance site (Plan B) was the build-up of the facility in time to meet the PRIME checkout schedule. Plan B involved a land instrumentation system on Eniwetok and was, of course, dependent on FY65 funds. Gaining funds at that late date would require Congressional approval. Information gained from meetings convened to discuss this plan indicated that it was unlikely that the complex could have been built in time for the June 1, 1966 checkout requirement even assuming funds were made immediately available. Hence, although Plan B was technically sound, it did not appear feasible from a schedule point of view.<sup>24</sup>

Plan C, which involved the use of the Navy's AGM-1 (Range Tracker) anchored at Eniwetok offered its own set of problems. Discussions with AFWTR and NRD revealed that the majority of the necessary equipment to support the terminal site was currently on board the AGM-1. No assurance was provided by AFWTR or NRD, however, that the ship could be anchored at Eniwetok for the

required terminal guidance checkout period, estimated to be four to six months or that it could be committed to a firm schedule for actual flight dates. Mobile facilities are always subject to major schedule changes and are highly dependent on the priority of the program competing for their services. The priority of the START program was well below other programs competing for this ship, i.e., Gemini, Apollo, and ICBM Ballistics studies. Information at the time actually revealed that the AGM-1 was scheduled to be in the Atlantic during the PRIME checkout and launch periods. Plan C, the ship instrumentation plan, therefore, appeared unwise unless the availability of mobile facilities could be assured.<sup>25</sup>

In summation of the three plans, the START Program Office had high confidence that implementation of Plan A would provide a high probability of mission success, on schedule and at minimum cost. The technical range safety aspects of PRIME appeared no more difficult than those of the ballistics reentering directly into the Kwajalein Test Range. Plan B, although technically acceptable, was dependent on the reprogramming of funds and a very accelerated build-up schedule. Based on information available, there was cause for concern that Plan B could be implemented in time to support the current PRIME schedule. Plan C was considered undesirable unless the availability of the mobile facilities could be assured. The Program Office recognized that the Plan B potentially represented the most desirable plan from a management standpoint. The management complexities of Plans A and C were not fully known at the time. Whatever the plan was to be, a decision had to be made soon or much effort by the Martin Company would be wasted in the interim. (The Martin Company was working toward implementation of Plan A). By late April SSD received the Range Safety Flight Plan Approval for PRIME. This was the final determining factor, and as a result, Plan A was the accepted plan. The TRADEX Radar and the PRESS instrumentation system would be used.

The Lincoln Laboratory of Massachusetts Institute of Technology (MIT) would provide support in the areas of planning studies, system installation and checkout, and during actual flight tests.<sup>26\*</sup>

Thus, by mid-1965, the PRIME project was very much underway. The Martin contract had been negotiated and at least for the moment, the Air Force could afford the program (several years later, at the height of the war in Southeast Asia, it might have been a very different story). Nevertheless, the Boilerplate project had been canceled earlier in the year, and even the studies portion of the START program was proving a hard effort to sell in Washington. The very important PILOT transonic and supersonic manned demonstrator project was also incurring delays in the approval cycle which surprised Program Office personnel. (However, the climate of opinion toward PILOT approval increased steadily and peaked in the fall of 1965 - see the lifting body case study). But, in the main, PRIME was robust and healthy; the next step was fabrication.

After program approval in November 1964, the next major technical step was better defining details of the program and flight tests in anticipation of a Preliminary Design Review (PDR). This effort took place during the first half of 1965. \*\* PRIME's PDR was held in Baltimore on May 20-21, 1965, and conducted without the benefit of a fully negotiated SV-5D Detail Specification because of the on-going cost reduction exercise being worked in parallel. Reviewers used a draft of the specification (the MB 1104), and this sufficed.

---

\*A complete history of the actual setup, checkout and performance of the terminal site, including the management approach, was written by then-Captain Victor Bunze, USAF, and was entitled "PRIME Terminal Area Operations," (Dept. of Astronautics, US Air Force Academy, n.d.).

\*\*This effort is well documented in Martin technical reports, and thus is not covered in detail here.

PRIME's suborbital test mission sequence of events is shown in Figure 9. \* It consisted of a launch from the Western Test Range (WTR) to simulate operational reentry conditions from 400,000 feet altitude down to a recovery point near the Kwajalein Test Site in the mid-Pacific. The SV-5D reentry vehicle would be fired from Pad 2 at South Vandenberg near Point Arguello using an Atlas SLV-3 launch vehicle. Separation of the reentry vehicle from the booster would occur immediately after Vernier Engine Cut-off (VECO) (see Figures 10 and 11). During exoatmospheric flight, reentry vehicle attitude would be maintained by the reaction control system. Reentry into the "sensible" atmosphere would occur at an altitude of 400,000 feet (well above the ASSET experience) with a relative velocity of the order of 26,000 feet-per-second, at a flight path angle of approximately -2 degrees. Shortly thereafter PRIME would experience peak dynamic forces ("max q").<sup>27</sup>

Following reentry, the vehicle would fly a guided flight path, matching a predetermined acceleration and roll program. In the atmosphere, trim and damping in pitch and roll would be provided aerodynamically by means of two hydraulically operated flaps. The vehicle would enter the ion sheath blackout region approximately 100 seconds after reentry, and remain in blackout for several hundred seconds, emerging about 400 miles uprange from the recovery point.

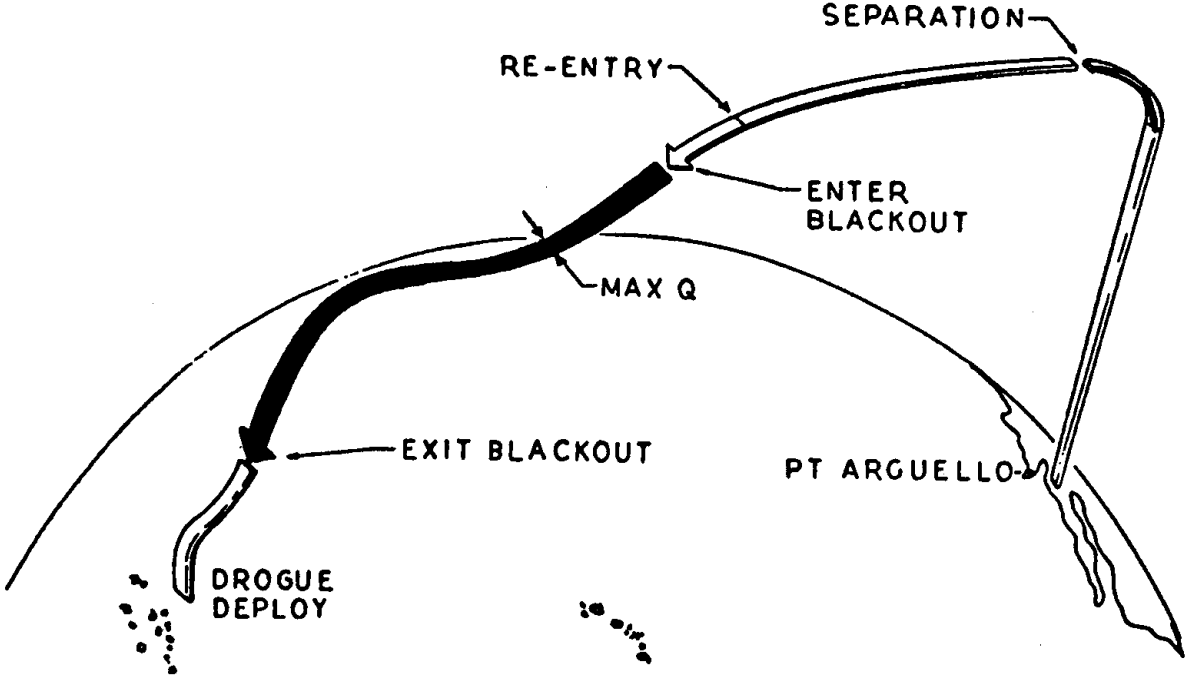
After emergence from blackout, the reentry vehicle would be acquired by the C-band radar of a range tracking ship located at a suitable point uprange from the Terminal Control Center at Roi Namur Island in the Kwajalein Atoll. Terminal guidance commands would be provided by a complex consisting of the TRADEX radar, a

---

\*In contrast to possible operational capsule-return orbital flights.



Figure 9

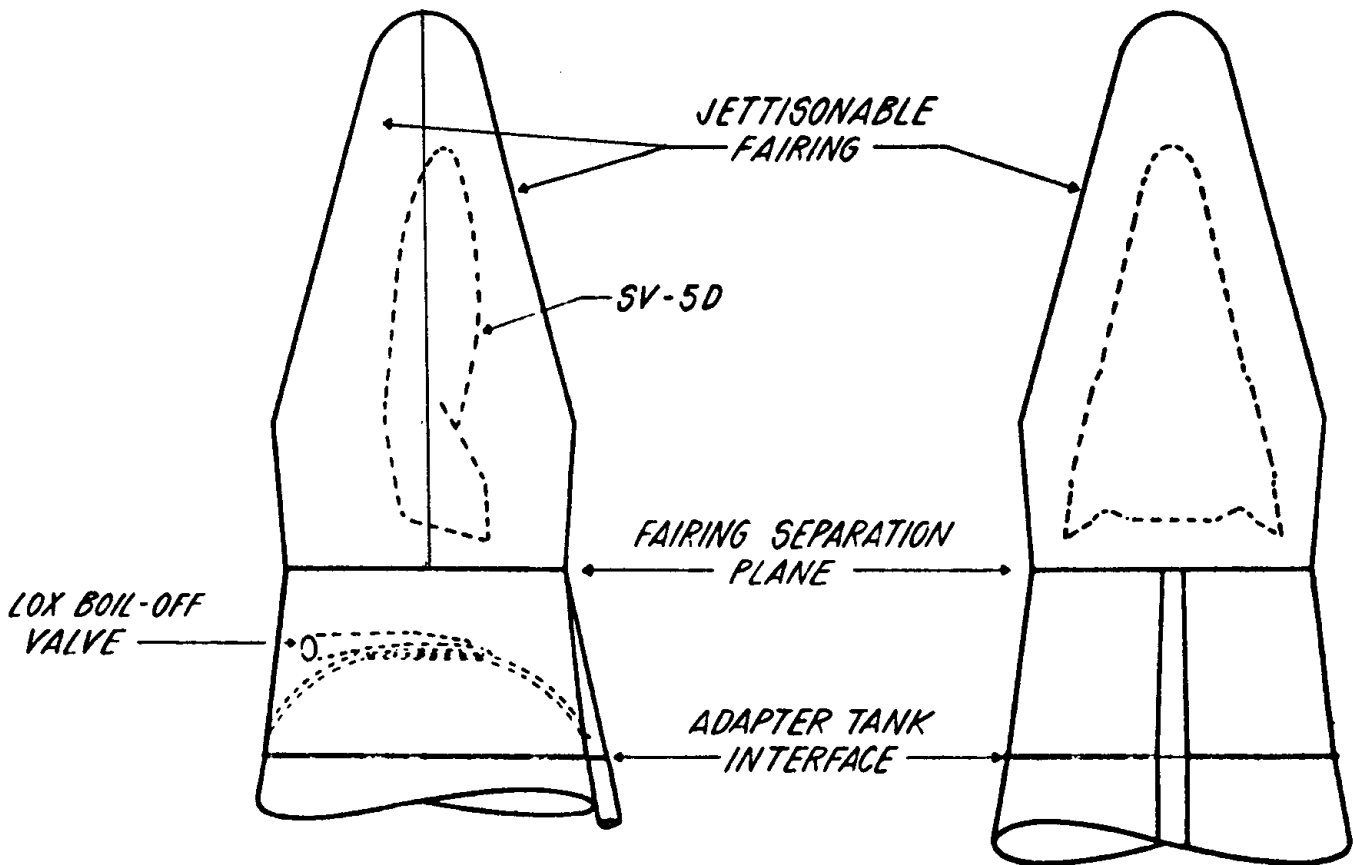


GENERAL SV-5D MISSION SEQUENCE OF EVENTS





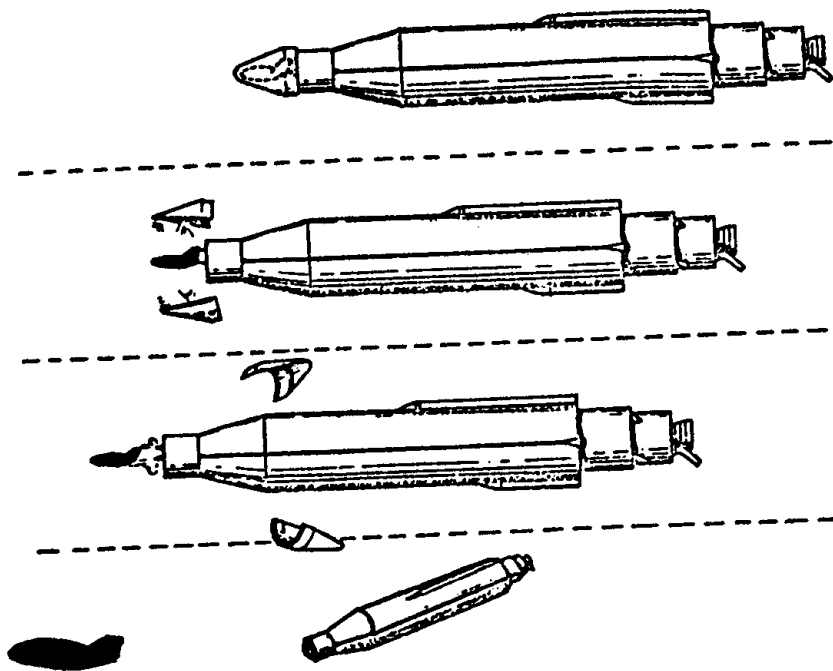
Figure 10



SLV-3 ATLAS AND SV-5D TEST VEHICLE INTERFACE



Figure 11



SEPARATION OF THE SV-5D FROM THE SLV-3 ATLAS BOOSTER

7090 computer, a UHF command buffer and AN/FRW-2 command transmitters. During the terminal phase, as with ASSET, telemetry data, stored on magnetic tape on board the reentry vehicle during blackout and prior flight, would be played back via a separate telemetry transmitter in reverse time sequence at twice real time to ensure acquisition of the blackout data.

At a Mach number between 2 and 3 (approximately 100,000 feet altitude), a drogue chute would deploy to decelerate and stabilize the reentry vehicle through the transonic range. At 50,000 feet, the main chute would deploy to decelerate the vehicle to a 25-foot per second sink rate at 10,000 feet, where the entire vehicle, dangling from the parachute, would be snagged and recovered by a JC-130B aircraft. As a backup mode, the vehicle would impact in the ocean and be recovered by surface vessels a la ASSET.

In general, the ground tracks of each test flight would follow a path pointing nearly due west from Vandenberg, passing north of Hawaii and Johnston Island and continuing to the recovery area slightly west of Kwajalein. The first flight would follow a "minimum risk" reentry profile (stepped angles of attack for moderate aerodynamic heating at zero bank angle), for the primary purpose of establishing nominal performance of the vehicle and functional compatibility of its subsystems, while demonstrating operation of the terminal guidance system. The second and third flights would be programmed to demonstrate partial and maximum feasible crossrange. Aerothermodynamic and heat shield technology data would be gathered on all flights.

Raw data from the vehicle tape recorder and real time telemetry tracking stations would be processed by Martin "quick look" analysis and conversion into computer language for further processing. Computer programs would be written to de-commutate the telemetered data, to incorporate calibrations and to convert data into engineering numbers in a format suitable for further

analysis and evaluation. Analysis programs would be developed for trajectory reconstruction and evaluation of the aerodynamic performance leading to additional efforts to evaluate performance of the heat shield.

Figures 12, 13, and 14 show inboard profiles of the SV-5D, including proposed operational models.

Since flight testing of the SV-5D configuration was to provide aerodynamic data for other scaled-up vehicles, the configuration's external hypersonic-supersonic aerodynamic shape was rigorously maintained. Over the entire PRIME test vehicle flight regime there were to be no major differences in the aerodynamic characteristics between the SV-5D and a larger unmanned or manned version.

The structure/heat shield system generally consisted of an ablative heat shield bonded directly to a load-carrying substructure. For the basic body, an elastomeric heat shield, ESA 3560HF, was bonded to a primary aluminum structure. The heat shield protected the structure to a limit temperature of 400 degrees F (estimated to be experienced at the time of drogue chute deployment). A carbon phenolic nose cap was mechanically attached to the frame. A heat conductive filler was installed between the nose cap and the ballast in order to utilize the ballast as a heat sink, in a manner analogous to that of a sodium-cooled exhaust valve functioning in a piston engine.

The flap structure was a beryllium plate which would act as both a load carrying structure and a heat sink. The lower surface heat shield utilized carbon phenolic while the upper surface was similar to the basic body, ESA 3560HF. The flap structure offered protection to a 800 degree F limit. The fins were of beryllium sheet, bonded to a steel honeycomb sandwich structure, protected to 800 degrees F limit temperature by the ESA 3560HF heat shield



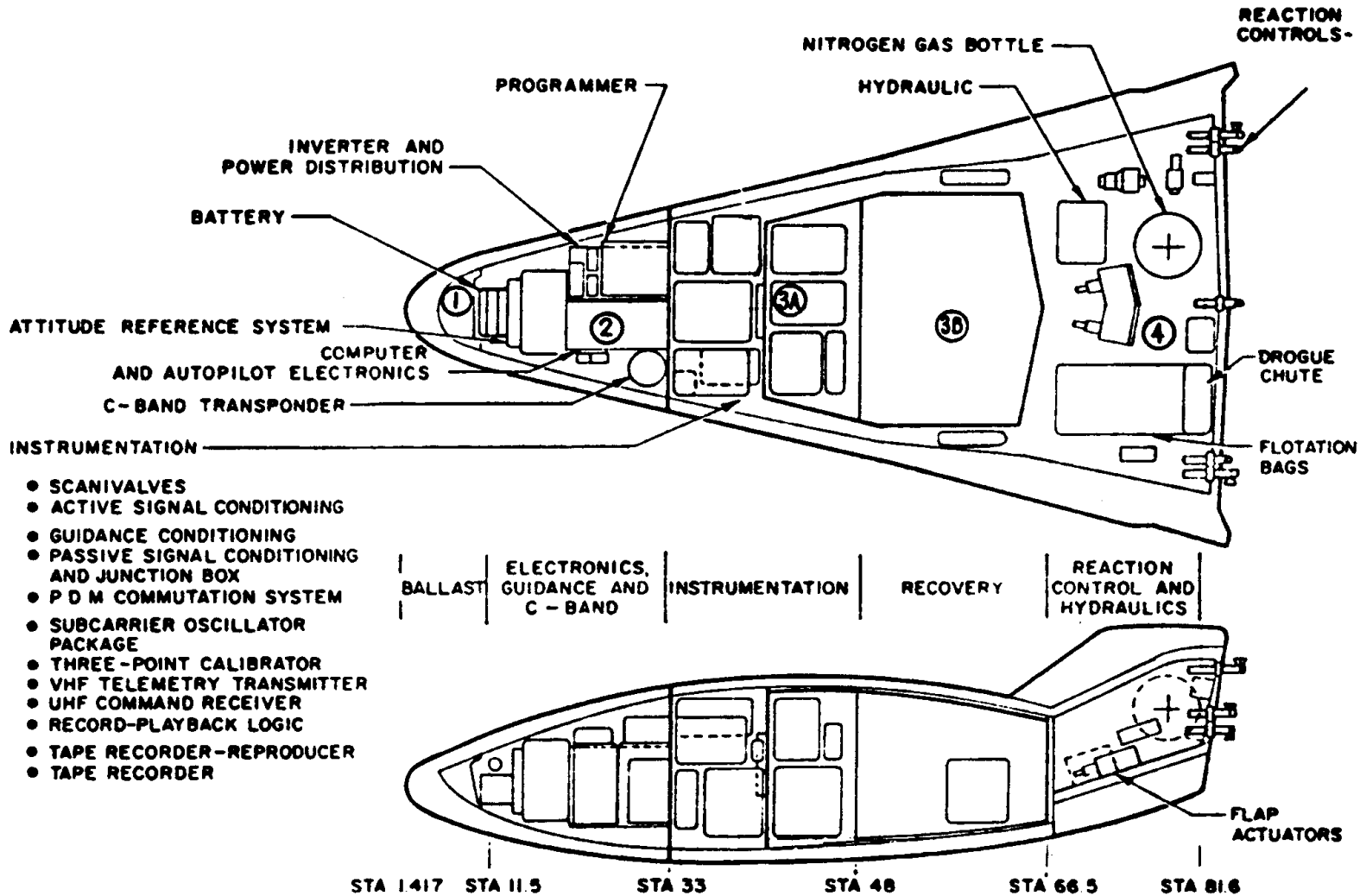


Figure 12





SV-5D OPERATIONAL VEHICLE INBOARD PROFILE  
 (EXTERNAL DEORBIT ENGINE)

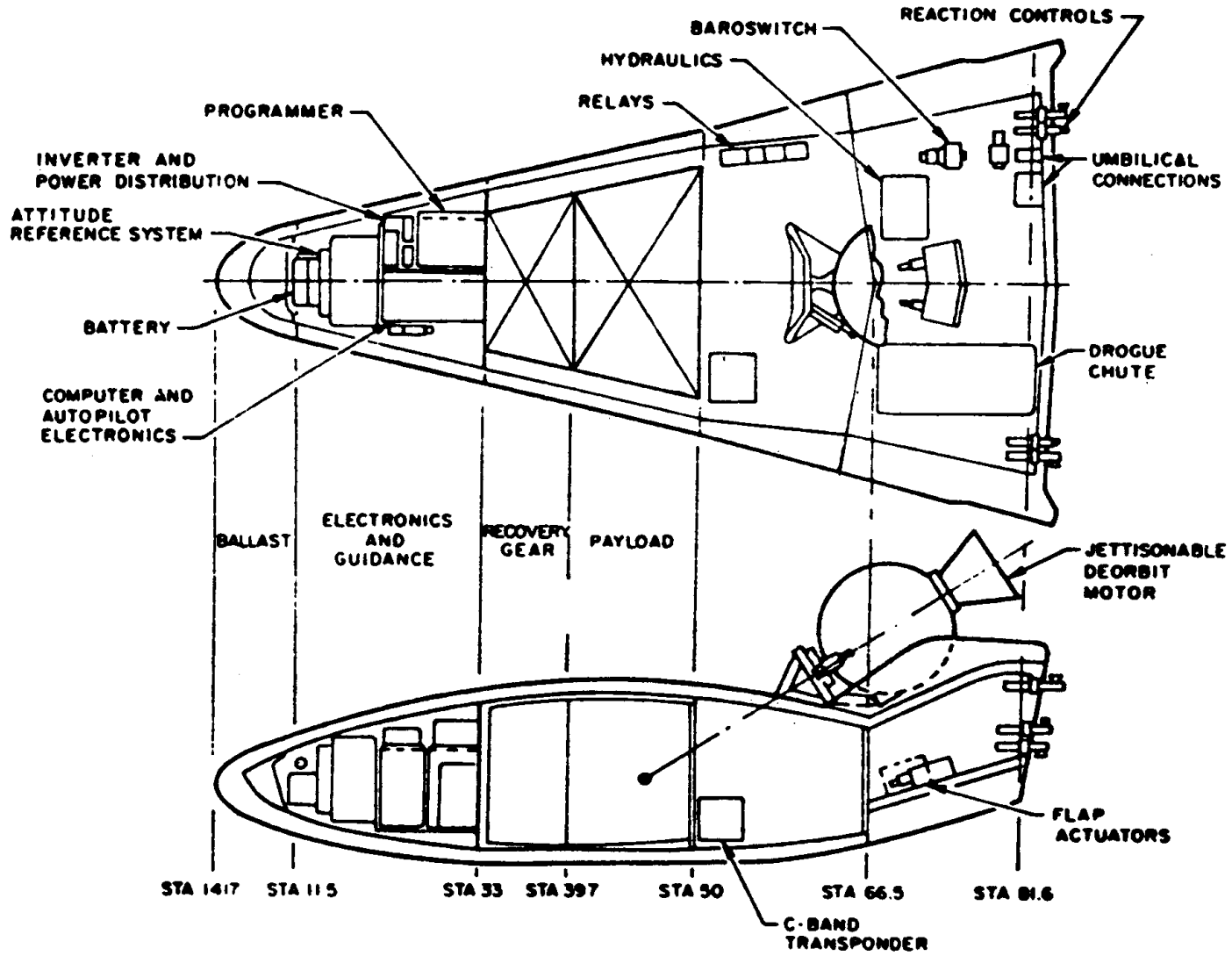


Figure 13



SV-5D OPERATIONAL VEHICLE INBOARD PROFILE  
 (INTERNAL DEORBIT ENGINE)

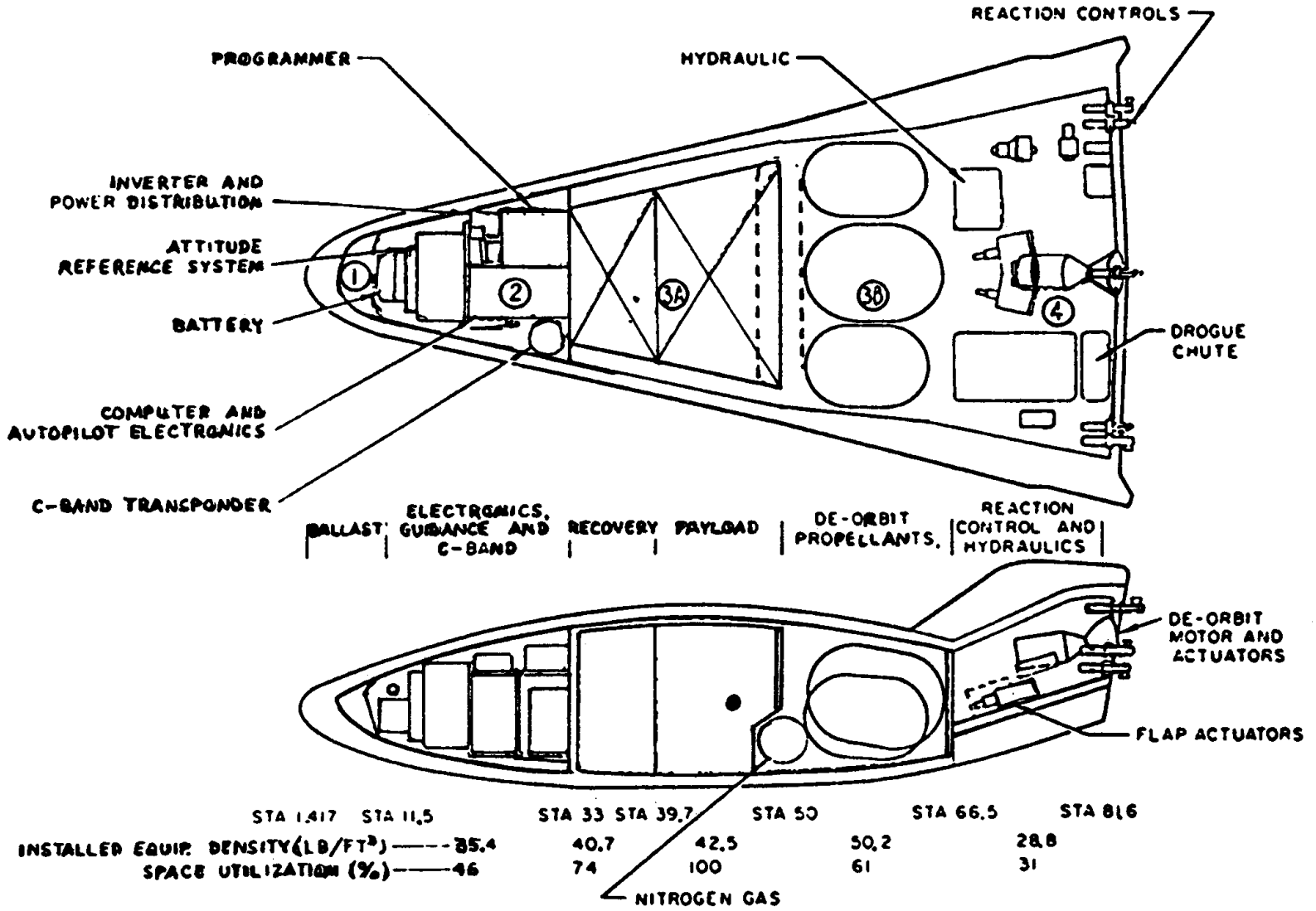


Figure 14

which was bonded directly to both sides of the sandwich. High heating rate areas other than the nose cap and flaps were protected by either carbon phenolic or a modified ESA 3560HF.

The guidance and control (G&C) system for the test vehicle consist of the following:

(a) Attitude reference and trajectory instrumentation system (ARTIS) containing an inertial sensor assembly of rate-integrating gyros and an accelerometer subsystem, both operating in the pulse rebalance mode, and the electronics associated with the operation of the gyros and the accelerometer subsystem.

(b) Inverter-power supply for the ARTIS and guidance programmer.

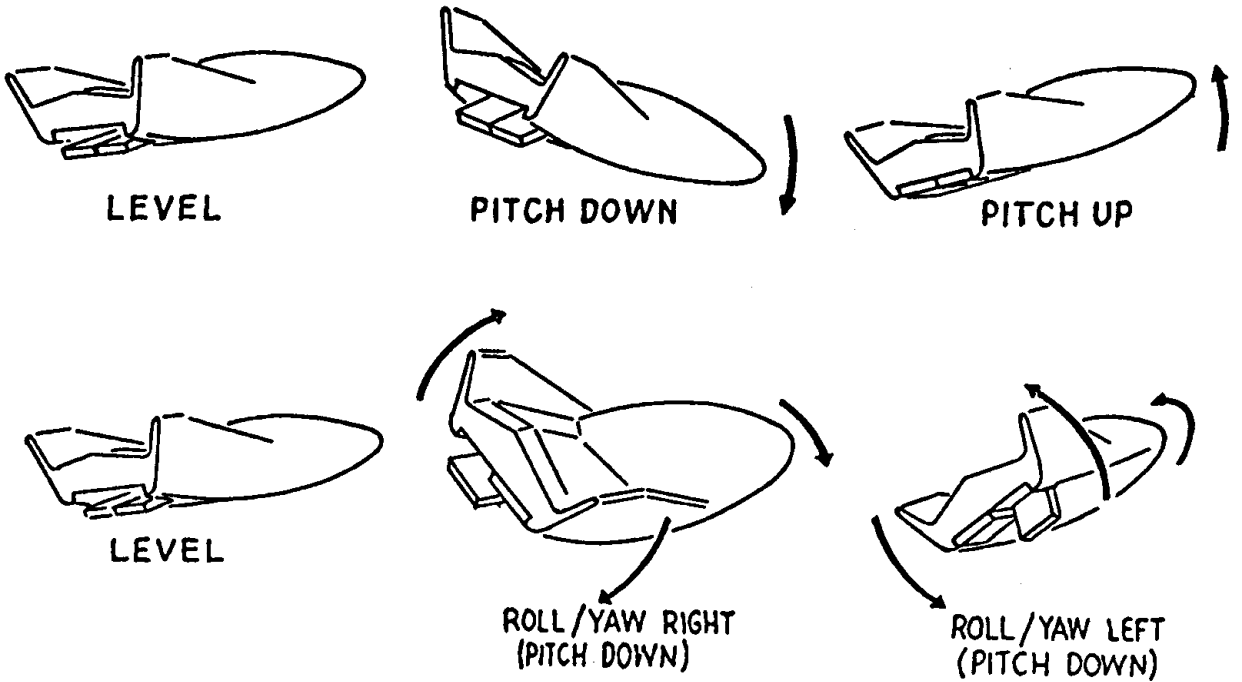
(c) Guidance programmer containing preprogramed guidance and control words and a computational capability required to transform these words into guidance and control commands.

(d) Autopilot, which would combine attitude error and rate signals to drive the 3-axis reaction control system and the 2-axis flap actuator system.

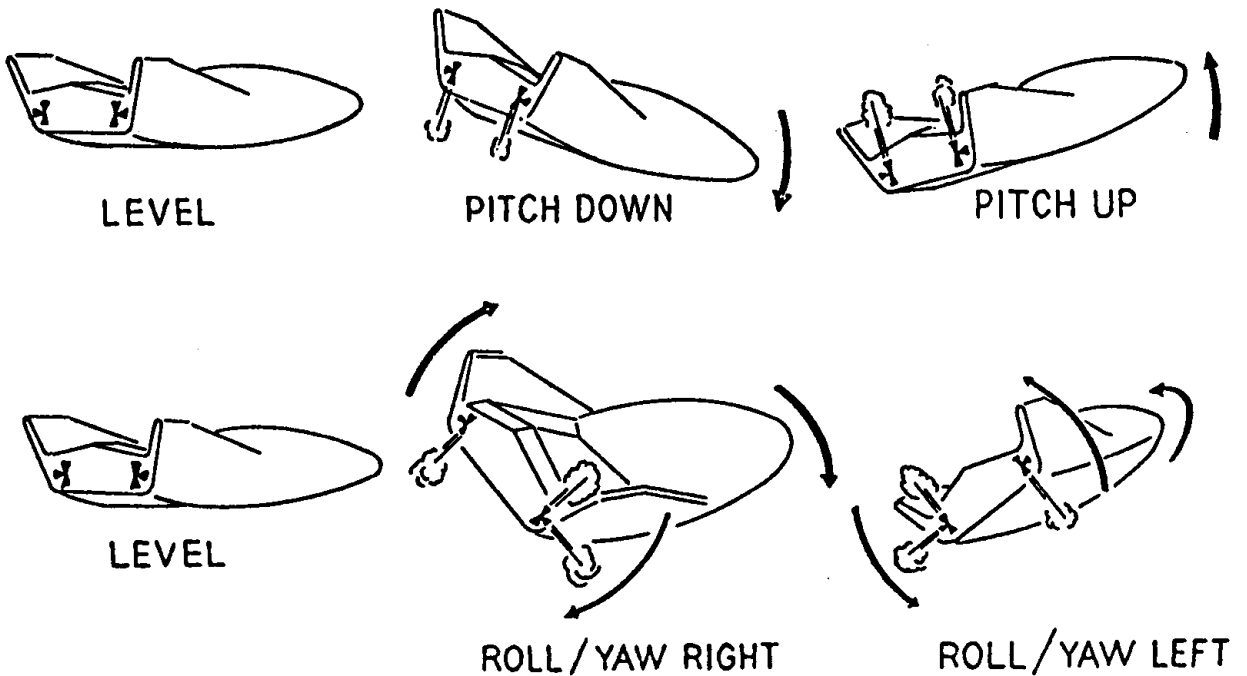
The two flaps were operated by a hydraulic actuation system consisting of a single combined motor-pump-reservoir unit connected to two actuators, two servo valves, two follow-up transducers and a filter. The guidance and control system would provide the signals to trigger control surface movement and RCS firings. The reaction control system provided sufficient thrust for the test vehicle to correct any initial booster/reentry vehicle separation errors, and would maintain vehicle attitude during the exoatmospheric portion of flight. The system consisted of a gas reservoir, fill, drain, and start valves; start valve, pressure regulator and filter, and solenoid-operated thrusters. Figure 15 shows operation of the aerodynamic (flaps) and reaction control surfaces.

The recovery system consisted of the drogue parachute, main parachute, flotation subsystem, location aids, and sequencing

### FLAP CONTROL



### REACTION CONTROL



controls. A ground command signal, backed up by an on-board signaling system, initiated recovery by releasing the drogue parachute. The drogue parachute decelerated and stabilized the SV-5D until, at an altitude of 45,000 feet, a barometric switch (backed up by ground command) released the main parachute. Figures 16 and 17 show the recovery sequence of events and the parachute configuration used on the SV-5D.

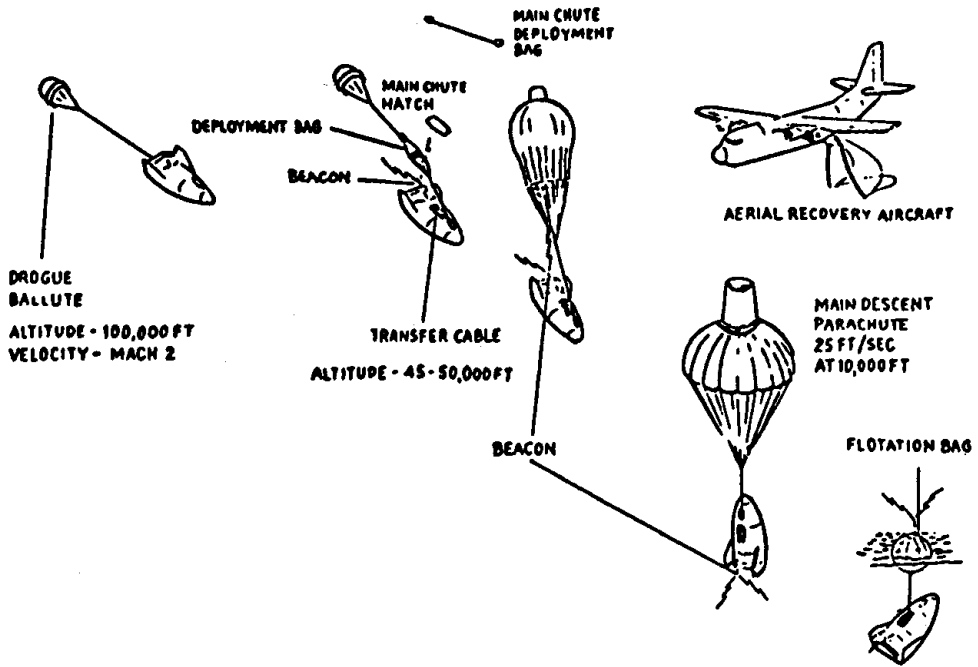
The environmental control subsystem utilized both passive and semi-passive cooling methods. The major heat generating equipment (such as guidance and telemetry components) were cooled by an evaporative method utilizing water-saturated wicking. Equipment not needing "active" cooling methods employed passive cooling techniques instead. Such items had "cold plates" attached to their mounting bases. The hollow cold plates were filled with wicking material and water. Perforated vent tubes were distributed through the wicking and manifolded to single vent lines and ducted overboard.

The SV-5D, unlike ASSET, lacked any on-board destruct system.

The telemetry, tracking and command (TT&C) system provided capability for telemetering instrumentation from the SV-5D, tracking its position, and commanding the vehicle during terminal guidance maneuvers. The principal parts of the system consisted of the telemetry transmitter, the C-band transponder and a UHF command system. An airborne instrumentation system (Figure 18) collected flight test data required by mission objectives. The instrumentation system, used only in the test vehicles, was installed in place of the payload that operational SV-5's would carry. The system provided an interface with monitoring sensors to accommodate subsystem measurements. An airborne PDM/FM/FM system operating in the 225- to 260-mc band and compatible with range receiving ground equipment acquired diagnostic performance and technology data. PDM/FM data was recorded on magnetic tape from

Figure 16

VEHICLE RECOVERY SEQUENCE

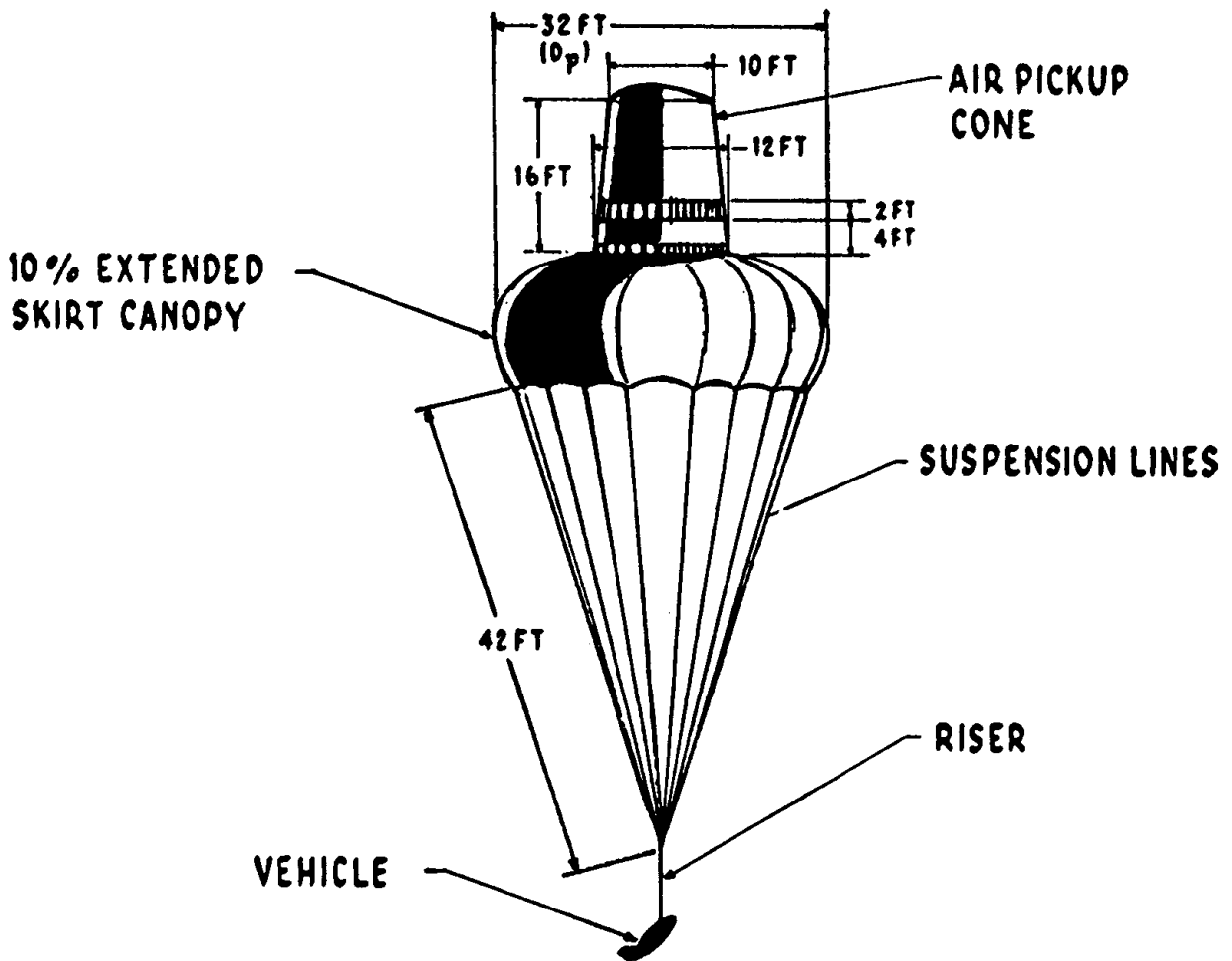


SV-5D RECOVERY SEQUENCE





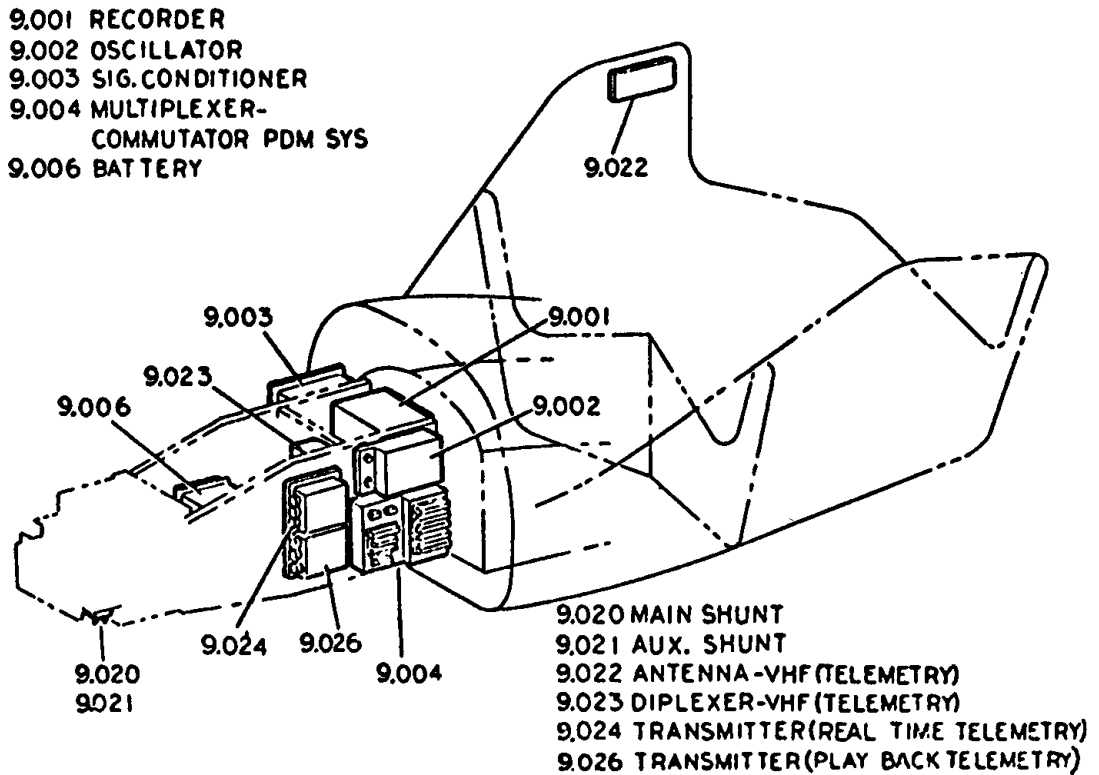
Figure 17



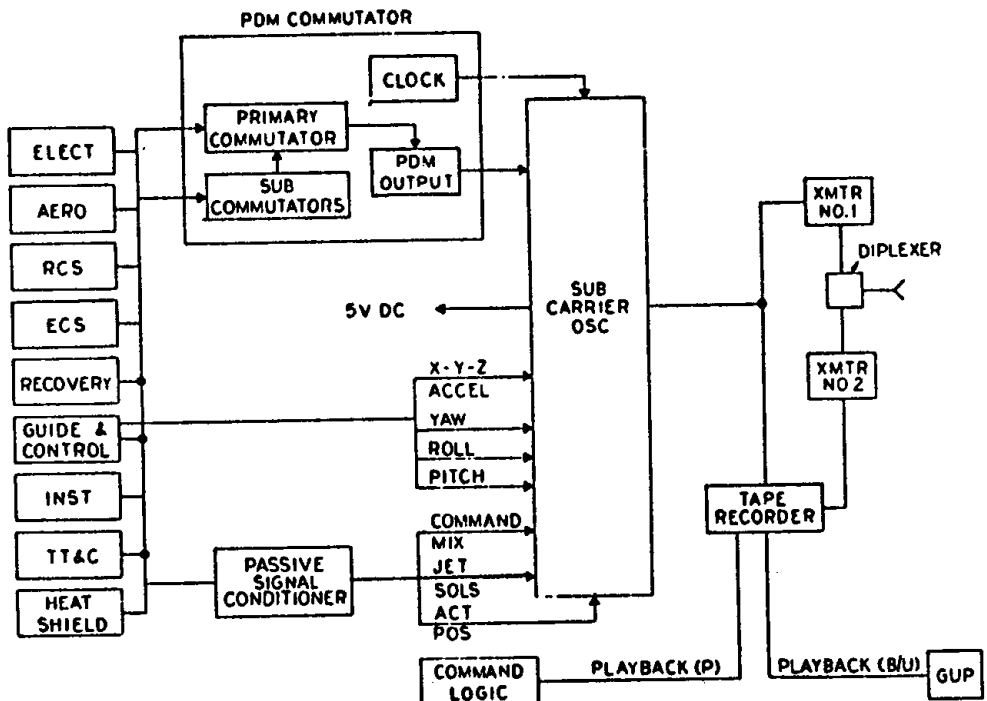
SV-5D PARACHUTE RECOVERY SYSTEM GEOMETRY



Figure 18



## INSTRUMENTATION SYSTEM



launch through blackout and played back after blackout simultaneously with real-time data transmission. Two separate VHF transmitters were used for this purpose.

The on-board electrical system supplied the 28-volt direct-current (dc) electrical power required by all the various subsystems except for the recovery subsystem, which had its own supply. When a system needed electrical power other than 28 volts dc, appropriate power was supplied by inversion equipment that transformed the 28 volts dc to the desired power rating. The power generation and power distribution subsystem consisted of a main battery supplying power for guidance and control, and telemetry, tracking, and command functions. An auxiliary battery supplied power to the hydraulic pump system and reaction control jets, and another battery furnished power to the instrumentation system.

Anticipated key milestone events in SV-5D development included:<sup>28</sup>

Critical Design Review	October 1965
FV-1 (Flight Vehicle)	
Fabrication complete	March 1966
FV-1 Delivery	September 1966
FV-1 Launch	November 1966
FV-2 Launch	February 1967
FV-3 Launch	April 1967
FV-4 Launch	June 1967

Martin completed subsystem design and development testing during the first half of 1965, and placed purchase orders for most subsystem hardware in June and July of 1965. The orders for the long lead items, such as the guidance system, occurred first. By late July 1965, some early tooling work began on the first SV-5D structure to be used as a test article. Like a butterfly on the verge of chrysalis, PRIME had left the drawing board and wind tunnel and embarked upon its hardware stage.<sup>29</sup>

## NOTES

1. Ltr, Colonel L. S. Rochte, Deputy for Technology, SSD, to Hq AFSC (MSFU), 11 March 1965, subj: START Hi-Speed Program.
2. "Program START, SV-5D Maneuverable Data Return Vehicle, Review of Size and Weight," 11 March 1965, p. 7.
3. Ibid.
4. Ibid., p. 8.
5. Ibid.
6. Ibid., pp. 8 and 12.
7. Ibid., p. 12.
8. Ibid., p. 13.
9. Ibid., p. 15.
10. Ibid., pp. 16-18.
11. Ibid., p. 14.
12. Ibid., p. 23.
13. Ibid., p. 28.
14. Ibid.
15. Ltr, Dr. A. Flax, SAFRD, to Dr. E. Fubini, Deputy Director, DDR&E, 13 April 1965, subj: START Program, Hypersonic Vehicle Growth.
16. Msg, SCGV-20429, AFSC to SSD, 22 April 1965.
17. Memo, General B. I. Funk, Commander, SSD, to General B. A. Schriever, Commander, AFSC, 30 April 1965, subj: START Program.
18. Ltr, Colonel L. S. Rochte, Deputy for Technology, to General B. I. Funk, Commander, SSD, 14 May 1965, subj: START Program.
19. Ibid.
20. Msg, SSG-10048, General B. I. Funk to General B. A. Schriever, 21 May 1965.
21. Memo for Record, Capt R. Gerzine, Chief, Test Operations Branch, 14 December 1964, subj: Trip Report to Vandenberg Air Force Base, 7 December 1964.

22. Memo for Record, Colonel C. L. Scoville, 5 March 1965, subj: Recovery, Tracking, and Terminal Base for PRIME.
23. Ibid.
24. Ibid.
25. Ibid.
26. Ltr, Colonel M. W. Elliott, Deputy for Range Operations, AFWTR, to the 6595th ATW, VAFB, Calif., 7 May 1964, subj: Range Safety Flight Plan Approval for PRIME Project Program 680A.
27. Minutes of PRIME Project Preliminary Design Review, Martin Company, CR-223.
28. PRIME Master Integration Schedule, May 1965.
29. PRIME Master Integration Schedule, August 1965.





## CHAPTER IV

### MANAGEMENT AND FABRICATION

Colonel Scoville's techniques for maintaining centralized program management included holding program review meetings at monthly intervals throughout the life of PRIME. In the early phases of the program, July 1964 to October 1965, these included meetings between Scoville, Barry Moss of Aerospace Corporation, and Joe Putegnat of Martin. Although associated key support personnel also attended, this triumvirate made all final decisions. Beginning in October 1965, and as the project moved toward the first flight, key individuals such as Howard Bonesteel from General Dynamics and Lieutenant Colonels Richard Palmer and later Warren Skeels from 6595th ATW also participated in these meetings. To facilitate the functioning of these program reviews, the program office prepared a Master Integration Schedule (MIS). The MIS was used as the major measuring device for reporting program progress. Not just a 1-page, top-level schedule, MIS consisted of about 15 pages of detail scheduling which permitted each project officer to determine how his subsystem or area was progressing in comparison with the total program. A great deal of emphasis was put on problem definition and thorough study of possible solutions. A weekly problem report was initiated and required from each agency supporting PRIME. Problems were categorized as critical, urgent, or potential. Critical problems were defined as problems which required immediate action in order to preclude (a) launch date slip, (b) increased program cost, or (c) reduction in vehicle performance.<sup>1</sup>

The October 1965 PRIME Management Review was held at Martin-Baltimore. The most important items discussed at the time

included launch pad activation in support of PRIME, interstage delivery schedule, electrical connector delivery schedule, interface shock problems and design of the main recovery parachute.<sup>2</sup> Colonel Scoville made it clear that the current launch services contract expired on June 30, 1967 and that funding difficulties would arise if the last PRIME launch slipped into FY68. Regarding interstage deliveries, Martin required dates for interstage test articles were not compatible with General Dynamics/Convair Astronautics dates and were resolved at the meeting. The electrical connectors which formed the electrical interface between the SV-5D and the interstage were a problem at this meeting and continued discussion and work plagued the project until almost the first launch. The delivery schedule for these connectors and their design specifications seemed to oppose one another from the outset. Martin had to define the environment for which the hardware was to survive, but Convair had to build and test the articles. Another problem area which stayed with the project almost until the first launch was the interface shock environment limits and their impact upon the design of the explosive separation bolts. The shock limitations and the requirement for a reliable separation system opposed one another continuously and no easy solution ever existed. Even hindsight does not offer an obviously superior approach to the management actions concerning these two interface problem areas.

A special Interface Panel Working Group was formed in mid-1965 to work the problems of the Martin-Convair interface. An interface specification was written with the purpose of controlling those interface characteristics which could not be changed by one associate contractor without affecting another. The characteristics described in that specification identified requirements between the associate contractors but did not constitute "design-to" constraints. The contractors had the option of meeting or exceeding the specified requirements in the design of the equipment which constituted their half of the interface. For

example, the Convair components which were part of the SV-5D obviously required withstanding the higher heat loads of reentry as well as those existing at the interface during the boost phase. The interface specification did not establish government acceptance criteria for end items but simply insured the successful mating and launch of the entire system. Hardware for the SV-5D made by Convair was designed and tested to requirements of the appropriate end item specifications. Martin stated the requirements formally for the items in the Government Furnished Equipment (GFE) specification. The government assumed responsibility for insuring that the appropriate Convair specifications contained these requirements.<sup>3</sup>

In mid-1965, a sharp increase in anticipated weight threatened to hamper the SV-5D. A launch weight of 890 pounds had been established as the limit for the reentry vehicle, but the predicted weight had already reached almost 880 pounds by June. A joint Weight Control Board was formed at this time.\* The board eventually met at approximately monthly intervals and included members from SSD, Aerospace and Martin; it reviewed weight changes, weight prediction methods used by Martin, proposed weight reduction ideas and reported progress to the Program Director following each meeting.<sup>4</sup> A drastic weight reduction exercise took place in June and July 1965 and as a result the anticipated weight of the SV-5D dropped to 795 pounds by early August. Although weight reductions grew more difficult - as could be expected - as time moved onward, the Weight Control Board met until mid-1966 when the predicted weight steadied out at about 860 pounds. The first SV-5D lifted off the launch pad at just over 858 pounds.

---

\*Weight control has always been one of the most demanding disciplines in aerospace vehicle design. Perhaps the SV-5's developers had, in the back of their minds, the distressing tale of the F-111 then unfolding.

In general, the START program office used the AFSC 375 series guide to systems management, following the broad intent of this management guide. However, much of the rigor and detail required when building an operational system was very judiciously trimmed away as this R&D program took shape. The SLV-3 program office at SSD handled booster procurement and ATLAS configuration control. The START program office procured the shroud interstage and separation systems and maintained configuration control. The major development item, the SV-5D and its associated AGE, was controlled completely by the START program office. The design requirement for the SV-5D stipulated that it must be capable of being easily converted into an operational system if such a need existed upon completion of the flight test phase. There was no assurance, however, that the SLV-3 would be the operational booster. For this reason, and the fact that it was decided to fit the SV-5D to the SLV-3, a general systems specification was not used, which, of course, would have controlled the total system under one cover.<sup>5</sup>

The START team pursued configuration management using four basic specifications as instruments. One specification covered the design, development and testing of the SV-5D. Only 37 changes were made to this specification in a 2-year period. A strict policy on screening specification changes helped reduce costs. A second specification governed the interface characteristics of the shroud, interstage, and separation systems. Two other specifications governed project GFE and the need at Roi Namur for terminal guidance of the SV-5D. Early in the program a specification was in existence covering all ground equipment peculiar to the program, but it was found that such tight control was not required by the Air Force on AGE and the program realized considerable savings by eliminating the requirement for this document. Specification maintenance was conducted in general accordance with AFSC 375 and all specifications were controlled by one Configuration Control Board (CCB) in the START Program Office. A procedure was followed at CCB meetings on each proposed change so

the meetings were conducted smoothly and all participants knew what was expected. Most of the coordination between the contractors and the Air Force was accomplished prior to the meetings, so the meetings took on the general character of approval sessions rather than questioning debates.<sup>6</sup> In order to further reduce cost Class I changes were defined as only those which effected contract price or schedule. Changes to the Contract End Item Specifications of any type required program office approval but a simplified format was used in lieu of an Engineering Change Proposal (ECP) as defined in the 375 series. In this manner it was possible to control performance, schedule and cost changes to the end items and yet provide ample flexibility in the design of the PRIME system.<sup>7</sup> It is only fair to state here that one of the underlying reasons to possibly give so much flexibility to the Martin Company in this area was because of the good configuration management practices which were habit to them after their fine work on the Gemini program. Many of the men that worked on PRIME came from Gemini and with them came the attitude of excellence which would not have been naturally found on an economically austere program as PRIME. The Air Force recognized this trait and utilized it to the best interests of the government.<sup>8</sup>

Like Polaris and other "high-tech" efforts before it, PRIME made use of PERT: Program Evaluation and Review Technique. The application of PERT was adjusted to provide only the information needed by the program office to provide confidence in overall project planning. The Master PERT network was maintained in the START program control room and was updated weekly based on information fed by the contractors and support agencies. The objective here was to assure that there were no significant program slippages that came by surprise. This, of course, was a means of reducing cost. The emphasis on schedule was based on a clear understanding that manpower could not be significantly reduced until after at least one successful flight and this, of course,

was directly related to money. The management approach used throughout the program was that if a few additional people or some limited overtime was necessary to keep some critical area or subsystem on schedule, then the choice would almost always be in favor of maintaining the launch schedule and thereby minimizing program dollars. A thorough cost analysis would accompany each decision along these lines.<sup>9</sup>

Once the test program had been defined and the specific flight test objectives had been agreed to, it was possible to establish specific performance incentives for the flight test program. It was recognized that vehicle recovery was undoubtedly the most difficult task, and therefore, the largest percentage (30%) of the performance incentives were placed on this item. Also recognized was the fact that everything else on the flight had to work in order to have an opportunity for vehicle recovery. The break even point was one recovered vehicle. The next largest percentage (20%) was placed on achieving our maximum cross-range maneuver and an equal emphasis was placed on the guidance accuracy. An equal emphasis was placed on data obtained. In this case, the contractor was rewarded if greater than 80 percent of the data available were obtained on each flight. He was correspondingly penalized if the percentage was less than 50 percent and the region of 50 to 80 percent was par. Similar arrangements pertained to vehicle cross-range and guidance accuracy. The remaining Martin performance incentive (10%) was on vehicle weight. Similar arrangements were incorporated in the Convair contract which rewarded them if the vehicle was "injected" within the desired vehicle altitude, velocity and reentry angle conditions, and separation of the shroud and reentry vehicle from the interstage were likewise covered in the performance incentives. Our other incentives involved cost and these arrangements were similar to practically all incentive contracts used by the government today.<sup>10</sup>

During October 1965 PILOT transferred to Wright Field, ASSET's "wrap-up" briefing was brought to Washington, and the PRIME project was nearing Critical Design Review stage, and scheduled for October 26-28. With the review so near, developers contemplated the problems they faced as SV-5 edged towards flight. For example, the recovery system caused particular concern. Drogue parachute tests had been conducted during July, August and September. The tests conducted in July resulted in chute failures and the redesign of the drogue chute, but supersonic drogue tests conducted in August and September were likewise unsuccessful. Transonic and supersonic tests of a ballute drogue device followed in September with satisfactory results. Northrop had been the planned vendor for the design, fabrication, and test of the drogue chute and the fabrication of the main chute. (The Air Force was going to assume responsibility for the design of the main chute). In late September Martin decided to terminate the Northrop effort and turn over all recovery system design, fabrication and testing to Goodyear Aerospace who had developed ballute drogue devices well suited for PRIME deceleration. In October the trade offer was made to Goodyear and the Air Force shifted design responsibility for the main chute to Martin. The Air Force eventually began recovery drop testing in December, following final design of the main chute in early October.<sup>11</sup>

On the management and program direction side, however, things seemed to go sour. In early October there were initial indications that the fiscal year funding situation was about to change for the worse. All reports from Washington indicated that FY66 funding would be cut from \$35.0 million to \$31.7 million. It also looked as if FY67 funding might be cut from \$16.0 million to \$10.0 million. A figure of \$17.5 million was requested for this year in the January 680A development plan. By the end of October, a justification for 680A monies was sent to Washington. It was stated that a minimum total program cost would result from funding of \$35.0 million in 1966 and \$17.7 million in FY67.<sup>12</sup>

Then, on October 19, Air Force headquarters rejected the Studies Package that had been submitted in July. Headquarters emphatically stated that the Secretary of the Air Force for Research and Development approval of advanced system design studies which implied that the Air Force was promoting a medium hypersonic L/D vehicle for maneuverable spacecraft operations would not be forthcoming. The Alternate Configuration Study, they said, was premature and should be deferred indefinitely. The four proposed subsystem studies (Heat Shield/Structure, Guidance and Control, Communications, and Instrumentation) were said to have merit but would not be forwarded for SAFRD and DDR&E review until they were technologically oriented and divorced from both mission applications and the concept of an advanced design medium L/D configuration. They were to be expanded to require a parametric analysis of advanced design subsystems across a wide range of L/D ratios, including evaluation of sensitivity of subsystem performance to the L/D variation. As a final note, the letter stated that since these studies would be independent of vehicle size and shape, they would be funded and accomplished under the Space Studies line item and not START's.<sup>13</sup>

The PRIME Critical Design Review was held on schedule on October 26-28, 1965. Most all the subsystem development testing had been completed in October and final drawings were even then being released for fabrication. Recovery subsystem testing was obviously behind schedule at this time due to the above mentioned problems.<sup>14</sup>

Management surprises continued in November. About the first of November SSD announced that the Aerospace Corporation would be withdrawn from the PRIME project completely and its phase-out would be completed in December 1965. Aerospace support numbered about 25 men and consisted of general systems engineering and technical direction. The question of how this effort would be replaced had to be answered by the program office. The time in



the PRIME project when this decision was made was critical. It seemed most appropriate that the Martin Company fill this vacuum in some manner but how to do so was not easily answered. If the Aerospace function had been turned over to Martin at some early point in the program it would have been best to separate this function organizationally from Martin responsibilities in order to assure objectivity and the ability to independently audit overall system development. What had to be assumed, however, was now the role of completing certain aspects of general systems engineering functions. The general systems engineering task was actually an extension and expansion of the responsibilities which the Martin Company had already been committed to supply in the statement of work. Therefore, considering cost, practicality, and time in the project at which the action was taken, it was decided that these additional functions would be assumed by the Martin Company through an expansion of the current Martin PRIME project engineering organization. The individual assigned to lead the effort at Martin would be completely accessible to the START Program Director. No objectivity would be lost by Martin conducting the general systems engineering since this now involved primarily detailed integration and coordination activities. The START Program Office retained overall technical direction, on the other hand, because this could not be assumed within the Martin project office without danger of loss of objectivity and effectiveness. The decision to use this approach in replacing the Aerospace Corporation proved to be quite a sensible and cost minimizing approach.<sup>15</sup>

In light of the anticipated funding shortfall rumored the previous month, AFSC headquarters requested that a briefing be prepared for November 20 on a suggested revision to the August 1965 development plan which would provide for the completion of the PRIME project within the funding limits of FY66 (\$31.7M) and FY67 (\$16.0M). Ground rules for the revision would

be completion of PRIME project on current schedule, all deferred 1966 fiscal year funds released immediately, studies canceled or deferred to later date, Aerospace support reduced (the TWX was sent before decision to eliminate Aerospace was made), and a FY67 start of a high L/D follow-on program. The latter ground rule did not seem to fit in with previous guidance. The briefing was later delayed until late December but the revised development plan was requested as soon as possible.<sup>16</sup>

During November SSD decided to add another SV-5D ground test article to the project. This was done in order to provide the capability of performing shock tests at an early date and to improve the ground test schedule with relation to the other program events such as the acceptance of the first vehicle. Vehicle separation shock, drogue mortar shock, hatch separation, and re-entry loads tests were planned for this test article, which had been taken out of the program in an effort to reduce cost but it was becoming evident at this time that the test schedule on the single test article remaining was just too tight.

The development plan forwarded to Washington in August had received its review by Air Force headquarters and it was submitted to DDR&E along with the PILOT development plan on December 3, 1965 under the following letter signed by Dr. Flax:

The attached START Technical Development Plan (TDP) is considered acceptable from a technical standpoint and is forwarded for your review. However, two parts of the TDP relative to studies and associated funding are undergoing review and updating at the present time. These proposals, while correct when written, have been affected by recent FY67 budget decisions.

The Studies package proposal was returned to the Air Force Systems Command (AFSC) on October 19, 1965, with a request to broaden four of the work statements and to consider these studies under the Space Studies program element. This change in direction will have an effect on the funding presently allocated under tasks 5 and 6 in the Financial Section of this TDP.

The FY67 funding is not in agreement without initial budget submission of \$16.0 million dated October 1, 1965; however, AFSC is presently reviewing alternatives aimed at keeping the SV-5D flight test program on schedule within present FY67 F&FP limitations. Although an Air Force recommendation resulting from this investigation cannot be presented until later, it is quite certain that the basic program objectives and schedules will not change. We do request release of the FY66 \$1.2 million presently deferred for application to the SV-5D program. Some flexibility in the use of FY67 funds to best advantage appears desirable and will be considered in the Air Force FY67 apportionment recommendations.

The low-speed SV-5P program has been investigated from several aspects and the various alternatives have been briefed to members of your staff. Additional SV-5P vehicles and a third B-52 for launch support were considered but could not be adequately justified. Our recommendation for a single low-speed vehicle and the two X-15 B-52s is described in the enclosed TDP for a low-speed lifting body technical program.

Management of this single vehicle program has been assigned to the Aeronautical Systems Division (ASD) and technical direction will be provided by the Research and Technology Division (RTD). The START Program Office at SSD will maintain continuing liaison with ASD and the flight test program will be conducted as a joint AFFTC/NASA-FRC effort. This can be accomplished under a new program element number or as a new project under the present START program element.

This program is estimated at \$2.4 million and is spread over a 5-year period. Procurement of the SV-5P vehicle would follow a limited competition between Norair and Martin and is estimated at \$1.3 million on a fixed price basis. The initial \$1.5 million FY66 requirement can be met with present START program funds.

I believe it is essential from a programing and contractual standpoint as well as to meet the jointly agreed NASA/DOD test objectives to proceed with this project without any further delay. Your early approval of this subject is requested.

The revised development plan requested by AFSC headquarters in November was forwarded to that headquarters on December 7. The

conclusion reached by SSD was that completion of the PRIME project within the funding limitations of \$31.7 million in FY66, \$15.0 million in FY67, and \$1.3 million in FY68 could be accomplished assuming no unforeseen complications arose. However, it was also necessary that the \$1.2 million deferred 1966 monies be released immediately and that assurance of the entire \$15.0 million in FY67 be given. The Martin and Convair contractor efforts and cost had been increased to allow for the replacement of the lost Aerospace support. Air Force project office manning requirements were also increased in the development plan.<sup>17</sup> Aerospace's swan-song came that same month. At the first technical direction meeting held under the supervision of the START Program Office in early December, a few Aerospace personnel attended as advisors.

Dr. John S. Foster, DDR&E requested a review of the requirements for Advanced Range Instrumentation Ships (ARIS) in the Pacific. The START program was one of the four Air Force programs along with Army and Navy projects which were to be so reviewed on December 14 by DDR&E. Major R. D. Gerzine and Mr. J. H. Ashmore were dispatched to present the START program requirements at this meeting. Nothing definite was announced at the meeting with regard to ARIS ship support.<sup>18</sup>

As the year ended, there were some early signs that the schedule was not being met in the area of autopilot fabrication and guidance and control system development and test. The guidance system was being supplied by Honeywell-St. Petersburg and was termed the CEGARS for Combined Entry Guidance and Attitude Reference System. Also, there were the first faint hints that Program 461, which preceded PRIME would suffer by not gaining access to the launch pad as planned. There were still some problems in getting Martin and Convair to agree to a delivery schedule for electrical connectors. By and large, however, START had weathered 1965 in fine form.

As 1966, the year of flight, arrived, the major unresolved problem of the START program was that its Determinations and Findings Document (D&F) for FY66 had not yet been approved. Although the negotiations with Convair had been completed, issuance of the definitized contract could not take place until after D&F approval.<sup>19</sup> On January 4 Dr. John S. Foster approved the \$1.2 million deferred FY66 money for PRIME. He also authorized that, within the money previously approved (\$30.5M), the Air Force proceed with the \$1.5 million effort for the PILOT project. With this approval, Dr. A. H. Flax signed the D&F on January 4, and progress was not hindered on PRIME. The Convair contract was definitized and distributed by January 14.<sup>20</sup>

Design, testing, and planning continued to go relatively smoothly. Several tests of the recovery system were conducted during January (Figure 9). The qualification testing to the ballute was completed on schedule at Arnold Engineering Development Center (AEDC) during the week of January 10. The first test of the main parachute was conducted at El Centro, California. The chute's conical extension was damaged during inflation. Continued testing of this same design was planned using different packing techniques.<sup>21</sup> The design of the interstage and shroud was completed on schedule and fabrication of this hardware began in mid-January. A group consisting of representatives from the program office, contractors, and the Test Wing visited Kwajalein during the week of January 10, 1966. During the visit, action items for preparation of the terminal site were considered. Sites were selected for program peculiar equipment. The trip was very useful in completing plans for the terminal site.

The major problems with SV-5D progress at this time were in autopilot failures during module tests on the prototype autopilot

and in qualification testing of the guidance system. The completion of qualification tests on the attitude reference platform and the programmer was projected for late May 1966 and this was already later than delivery of hardware for the first flight article. This condition could therefore result in modifications to flight components after installation in the reentry vehicle. Such modifications could invalidate systems test and checkout and result in repeated tests which would impact the vehicle flight date. Special effort was directed in this area by the Air Force, by Martin, and by Honeywell. Questions with regard to the interface electrical connectors forced some changes in design and delivery slips on these end items. Fabrication of the first SV-5D ground test article was completed in January and work began toward getting the heat shield applied to it.<sup>22</sup>

The January PRIME Management Review was held on January 4 at Convair in San Diego. This was the first review at which the Master Integration Schedule was used as a management tool. Colonel Scoville also initiated his problem reporting system, described in an earlier chapter, at this meeting.<sup>23</sup> The February PRIME Management Review was held at Martin-Baltimore on February 10. Considerable progress was made in ensuring the Master Integration Schedule became a more usable tool. At this meeting some schedule slips were reported. Development tests of the structure and heat shield were behind schedule, thanks to fabrication problems; the fin structure had been designed to be made of beryllium but in development tests the beryllium had cracked. Engineers decided to use stainless steel in place of beryllium and redoubled efforts to get back on schedule. (The vehicle's weight increased about three pounds with this change). The recovery main chute was again tested on February 2, and the cone again failed to deploy successfully. Two weeks later, the third main parachute drop was conducted on February 15 and the cone again failed to deploy.<sup>24</sup> Delivery of the recovery system for FV-1 (Flight Vehicle number one) had moved into May as one of the last systems

to be delivered. The guidance programmer proved a problem area, but autopilot testing was progressing satisfactorily. Copper was in short supply at this time and problems were had in getting the proper cables needed for setting up the AGE in the acceptance test facility at Martin. SV-5D predicted weight had grown to 856 pounds as reported at the meeting. Again, some changes in the design electrical interface connectors forced some delivery dates to slide in that area. The design of the receptacles that belonged on the aft face of the SV-5D was found to be unacceptable thermally and structurally.<sup>25</sup>

On February 11, General E. B. Giller (AFRST) sent a letter to AFSC approving both the PRIME and PILOT Development Plans with minor modifications. This letter emphasized that "ASSET, PRIME, PILOT, and Advanced Maneuvering Entry are now projects within START." This letter emphasized that the ". . . present FY66 START funds will have to suffice for both high-speed SV-5D (PRIME) and low-speed SV-5P (PILOT) Projects." It further stated that if additional FY67 funds were required, Systems Command would be requested to identify the specific requirements at apportionment and to indicate the sources for these funds. This letter also emphasized that the PILOT project had been returned to START and would be funded under 6.34.09.87.4.

Perhaps in response, a message was received for Systems Command on February 15, 1966 which requested that they be provided with a description of the extensions or variations to the PRIME project which could also be considered as possible START follow-on work. Headquarters itself suggested: refurbishment and reflight of a recovered PRIME test vehicle, orbital demonstration including de-orbit, reentry and precision recovery, variations of the SV-5 configuration to give higher hypersonic L/D ratio, heat shield experiments, including both ablative and radiative materials, communications experiments, and guidance and control experiments. AFSC requested a suitable response by March 7, 1966.<sup>26</sup>

On February 25, success came at last to the parachute recovery program, with a successful parachute drop test at El Centro, California. The next series of drop tests proceeded to higher dynamic pressures. The first of these tests was conducted on March 7. The cone deployed on this drop but the canopy ripped. Captain I. J. Gennaci, the recovery project officer, and Henry Epple of Aerospace visited Goodyear Aerospace in Phoenix, Arizona to survey the manufacturing practices used in making those parachutes that ripped when they were dropped. It was a disconcerting trip. The manufacturing techniques were found to be very crude and the quality control was almost non-existent. The main problem seemed to stem from the fact that the Goodyear people had no experience in fabricating parachutes. Mr. Epple was an expert in the field of parachute design and manufacturing techniques. Action was initiated immediately by the program office in order to correct the many deficiencies found in Phoenix. In early March Daniel J. Brockway of DDR&E and representatives of the Institute for Defense Analysis were briefed at SSD on PRIME project progress. SSD staffers were encouraged by Brockway's strong expression of confidence in the management of the program.<sup>27</sup>

In mid-March SSD was directed to transfer \$500,000 to Aeronautical Systems Division (ASD) for the initiation of the PILOT project. This money, it was assumed, was added to the PRIME project budget in FY67. Direction also stated that future PILOT funding would be out of the START line item. A problem still existed in FY67 since only \$16.0 million was programed against a required \$17.8 million.<sup>28</sup> But the major happening in March was realization of a potentially serious problem: the slippage of Program 461 which preceded PRIME on Point Arguello Launch Complex (PALC) 1/Pad 2 at Vandenberg. In order to support a PRIME program launch on November 22, 1966, access to the pad for PRIME would be required by August 9. Previous 461 schedules were compatible with this plan, but by late March, the most recent schedule of Program 461 revealed the last launch would occur on September 20;



thus, 42 days of PRIME modification time on this pad would be negated. In order to minimize the effects on each program several alternatives were considered and evaluated in late March. The first alternative would be to complete 461 as expeditiously as possible and slip the first PRIME launch accordingly. The PRIME launch schedule would be compressed as much as possible. This approach would probably result in minimum total cost to the government; however, it appeared that a planned 50 days between the first and second launch would not allow sufficient time to make flight 1 results available prior to flight 2. It must be remembered that six months elapsed between the first two ASSET launches. This alternative was determined as too compressed for PRIME and was eliminated immediately. The second alternative would also assume completion of 461 as indicated in the first alternative, and allow 80 days between flights 1 and 2 of PRIME and 50 days between succeeding flights. (Even 80 days would be difficult to achieve between the first 2 flights.) The cost of PRIME would increase about \$3.8 million. The third alternative would complete the first two 461 launches and defer the third until after the November PRIME launch. The remaining PRIME flights would be conducted on schedule and adequate time between the first two launches of PRIME would exist for any required modifications to hardware. The chief disadvantage of this alternative was that the delayed 461 launch would cost an estimated \$3 million. This option was attractive to PRIME, but not to 461. There were also some technical facts pertinent to this alternative which made it unattractive but their classification does not permit inclusion herein. Some additional facts that were pertinent at this time were that the PRIME project remained on schedule for the November launch and that a decision would not be required until June 1966. Waiting until June would give a better prediction as to the PRIME ability to launch on schedule and also would give time for the project office to determine what PRIME activities could be carried on in parallel with 461 while they occupied

the pad. A decision was therefore postponed regarding the PRIME/461 launch schedules.<sup>29</sup>

April 1966 opened with its own problems, notably a resumption of recovery problems. The seventh drop test of the main chute was conducted on April 4. The lines attaching the chute to the double "D" ring failed subsequent to the recovery attempt. A review meeting was planned at Goodyear immediately. The recovery system problems seemed to become worse when a recovery test vehicle was lost in the Pacific during an open sea test to check out the water recovery system. The cable attaching the vehicle to the flotation bag had rubbed against the vehicle with the motion of the high seas and had been frayed through to the breaking point.

A PRIME Technical Direction Meeting and Management Review was held at Martin-Baltimore on April 18-20. In addition to the normal coverage at such meetings, specific attention was devoted to technology to be acquired by PRIME. Colonel Tenold from RTD headquarters attended as well as William Lamar, Alfred Draper, and other representatives from the Flight Dynamics Laboratory (FDL). As a result of this session, the FDL staff volunteered to submit a written review of the PRIME project with comments and recommendations regarding possible additions to better satisfy technology requirements.<sup>30</sup>

SV-5 steadily advanced to completion. A milestone of sorts was reached on April 1 when Convair delivered the first set of electrical interface receptacles for checkout and installation in FV-1 at Martin. Fabrication of the first flight interstage was well along in April and the first interstage test article had been delivered to Martin on schedule. The Command Buffer Unit to be installed at Roi Namur for terminal guidance of the SV-5D was completed in April and the First Article Configuration Inspection was held on April 27. The heat shield was being applied to FV-1 in April and the final contouring and fit check was approaching at

the end of the month. There was also an increase in activity in the SV-5D Acceptance Test Facility (ATF) in Baltimore directed toward the checkout of all the ground equipment to be used in the testing and checkout of the SV-5D. The weight of the SV-5D stood at 859 pounds at the end of April. The monthly expenditure rate on the Martin contract during the Spring of 1965 was about \$1.7 million. The actual funding liability was at \$33.4 million with a projected value of \$45.3 million at completion. A total of 662 men were working on the PRIME project at Martin in April. The maximum had been reached in November at 759 men.<sup>31</sup>

Establishing a first flight date remained a nebulous business. The START program office completed a schedule/cost study in early May which indicated that a November 23 launch date could still be achieved assuming availability of the pad by September 20, 1966. The cost to the program would increase, however, due to the compressed pad activation schedule, and would be about \$700,000. (If the launch were slipped to January 1967, the increased program cost would be at least \$1 million, assuming the final launch would be in July 1967). The least expensive approach would be to launch about mid-December with pad availability on September 20. The final decision would still be made in June although analysis would continue.<sup>32</sup>

Problems continued with the recovery system in May, particularly with air pickup loads and packing density of the main chute. The loads imposed on the chute during recovery had on two occasions ripped the cone out of the main chute. Action was being taken to strengthen the chute suspension lines, to increase the elasticity of the suspension lines, and to provide a snubber device in both the aircraft and the cone to reduce the loads on the chute. The packing density was already very high and increasing the strength of the suspension lines would compound the problem. A solution, of course, was to reduce the size of the

chute. The descent rate had been limited to 25 fps but the recovery forces agreed to an increase to 27 fps allowing a decrease in chute diameter to something less than 48 feet. Tests on these new chutes would take place in June.<sup>33</sup> By mid-May, FV-1 was approaching the final stages of fabrication. The nose section and aft body section were contoured and structurally complete. The equipment beam was installed on the aft body although several pieces of hardware were still missing. There were two processes that seemed to slow the final heat shield fabrication. Martin had trouble getting the honeycomb bonded to the fin substrate and, secondly, getting a good fit of heat shield protective edge members was profoundly difficult. Honeywell was working 7-day weeks and 24-hour days on the guidance system and it looked like a late May delivery date for the FV-1 units. Vibration qualification tests on the guidance system were causing most of the problems during May. Most of the subsystems were having problems but the major problems were unquestionably in the guidance and recovery subsystems. The separation system also presented its share of headaches. The explosive bolts presented a major concern. It seemed to be impossible to design a highly reliable explosive bolt that stayed under shock limitations delivered at separation. Convair had planned a method of attacking this problem and made an outstanding effort to find a bolt to do the job within the time remaining.

At the May PRIME Management Review, Colonel Scoville emphasized cost and stated that there was essentially no money remaining to solve problems. Engineers would have to devise economical methods to solve the current problems and not risk the success of the mission. The objective was still a September delivery of FV-1 and a November 23 launch date. Solutions to problems had to be decided on quickly so that immediate action could be taken. Time was running out.<sup>34</sup> By the end of May, the Baltimore Acceptance Test Facility (ATF) was ready for FV-1 and a SV-5D ground test article was being used to check out handling procedures. The vehicle's weight stood at 856 pounds. The command buffer unit was

delivered at Kwajalein and installation was underway. The expenditure at Martin in May was \$2.2 million against a planned \$2.0 million. Total staff on the project had, however, dropped to 562.<sup>35</sup>

On June 19, 1966 FV-1 was moved into the Acceptance Test Facility to begin the long series of tests that would prepare it for the Air Force acceptance. Everything was not completely smooth at this time with FV-1 however. The men of the Martin acceptance test team headed by Messrs. Dan Weller and Al Ryan would have a difficult job ahead. Air conditioners required to cool the vehicle whenever power was applied were old government surplus items that broke down quite frequently. It was difficult to keep one of the two operative at all times. A new air conditioner was ordered for July delivery. The guidance system in FV-1 at the time was not in flight unit and had to be changed. About 11 pressure transducers were unavailable for installation in the nose section and would have to be installed on a non-interference basis. Spares were never in abundance, it seemed -- certainly a schedule "buster" when testing begins. A major milestone was reached when the flaps were installed, fitted, and were made to work properly.

June brought mixed results on the recovery system development scene. Two drops at high dynamic pressure (45,000 feet, Mach .6) of the main parachute were made on June 6, and the parachute was successfully recovered. Two additional drops were scheduled on June 16 and 17, 1966 with the intent of completing the development and verification testing at that time. Unfortunately, the cone on the first of these drops did not erect properly. Analysis of the recovered parachute revealed that some of the lines had been improperly stitched and had torn out on deployment; obviously, quality control problems were continuing. The manufacturing method was immediately corrected to solve this problem.<sup>36</sup> During

the June Management Review, then, the recovery system naturally was one of the problem areas discussed. Everyone was anxious to be able to end development testing, and Martin insisted that the criteria would be two consecutive successful drops on one chute design. Bastian "Buz" Hello, who replaced Joe Putegnat as Martin's Program Manager in early spring, promised that if problems then arose during production chute drops, the development effort would commence again. Hello, a no-nonsense and extremely competent engineer, had worked in the aerospace field since the days of America's first combat-worthy jet fighter, the Lockheed XP-80. Colonel Scoville agreed to this but insisted that two or three high dynamic pressure drops be among the first production chute drops. The production rate of parachutes was now the problem. At the outset, only two chutes could be fabricated per week; later, the rate would increase to eight. The projected delivery date for FV-1 still remained at September 23, 1966 even though FV-1 would reach the acceptance test facility six weeks late, necessitating a second shift and weekend work to meet the schedule.<sup>37</sup> June closed with the SV-5D weighing 858 pounds. Martin's monthly expenditure rate dropped to \$1.2 million in June, and the total personnel on the project continued to decline to 531. The total money expended by Martin on PRIME to date was about \$36.8 million.<sup>38</sup>

In late June, a key review team inspected PRIME facilities in the Pacific. A group consisting of Colonels L. S. Rochte, Norman J. Keefer, and C. L. Scoville visited the PRIME terminal site at Kwajalein and Roi Namur during the week of June 27, 1966 to assess its progress towards the upcoming SV-5 flights. The trip was very worthwhile in permitting a good crossflow of information between the several agencies involved in support of the PRIME project. They were briefed by the Army at Kwajalein and by the Massachusetts Institute of Technology (MIT) people on Roi Namur. As a result of this trip, confidence was increased in the effectiveness of the set-up in the terminal area. During this

same trip described above, the PRIME team met with the recovery forces at Hickam, Hawaii for a briefing on recovery force operations. Disturbingly, a test of the main chute on June 30 failed miserably. The cone did not deploy, and for a variety of reasons, recovery could not be attempted. Inspectors examined the chute after ground impact and found that one cutter on the cone bag had fired but did not cut the line completely; the lanyard for the second cutter ripped off before the second cutter fired.<sup>39</sup> On July 5 another chute was dropped. The cone deployed and upon aerial snatch of the chute the load lines in the cone broke. A design meeting was held immediately.

In early July, \$15 million was released to the START program office for application to the PRIME project. The other \$1 million programmed for START was released directly to ASD for use on the PILOT project.<sup>40</sup> On July 15, General Paul T. Cooper, SSD Vice Commander, was briefed on the continuing PRIME/461 pad conflict. It was recommended that 461 be completed as expeditiously as possible which would be a final launch on September 26. PRIME would then take over the pad and could be ready to launch on December 6, 1966. This, however, would require a second shift and some overtime work resulting in a total cost increase to PRIME slightly in excess of \$1 million.<sup>41</sup> Following the briefing, General Cooper signed a message to AFSC that the PRIME Beneficial Occupancy Date (BOD) had slipped from August 8 to September 27 and that by careful planning the slip in the first PRIME launch would be only two weeks. AFSC responded to the message and requested that the Program Directors discuss the details with the AFSC staff in Washington. This meeting took place on July 26 and essentially the same briefing was given that had been delivered to General Cooper. Following this meeting, AFSC requested that SSD study several alternatives to the SSD recommendation and present the results at the Quarterly Review at SSD on August 22 and 23.<sup>42</sup>

The July Management Review was held at Vandenberg to familiarize the management group with the operations of that facility as well as to provide an opportunity for top level Vandenberg personnel to become familiar with the PRIME project and its present status. The monthly PRIME Management Review was held at Vandenberg AFB on July 20. Colonel Scoville announced the change in launch dates and also that FV-1 delivery would now move from September 23 to October 17. He asked that Martin make use of this additional time by working to make FV-1 a more reliable flight article and by reducing program cost. This would be done by adding or modifying test plans to increase the confidence level in FV-1 and to eliminate, as much as possible, overtime and weekend premium labor to reduce cost. Convair was similarly directed. The revised launch schedule anticipated PRIME launches on December 6, 1966 and February 21, April 18, and June 20, 1967. FV-1 was moving through subsystem checkouts and was about 90 percent complete by the end of July. After the subsystems checkout, a series of combined systems tests (CST) would lead up to vehicle acceptance. This series consisted of a first CST, an EMI CST (a check for electromagnetic interference), a shock CST (to simulate separation shock), vibration CSTs (simulating launch and reentry vibration in three axes), and finally the acceptance CST. Problems at the management review were in the areas of guidance, recovery, separation system delivery schedule, and electrical connectors, but all seemed as though they were manageable. PRIME was beginning to come together nicely.<sup>43</sup>

Colonel Scoville journeyed to Washington and Baltimore on July 24-27 to attend meetings at the Pentagon, AFSC headquarters, and to review the progress on PRIME at Martin. The purpose of the Pentagon meeting was to inform John Kirk, Assistant Director for Space Technology, and Daniel J. Brockway of current information on the status of PRIME and any conflicts that might impact PRIME's funding requirements. Colonel Scoville lead off by reviewing program objectives. Mr. Kirk replied that although there was some



interest in future manned applications he felt that the Director of Defense Research and Engineering (DDR&E) did not desire to change the program objectives. He emphasized the position taken during Secretary of Defense Robert McNamara's recent trip to Los Angeles to review MOL and commented that further emphasis on SV-5's manned application would not be possible - i.e., desirable - at this time. Next, the discussion turned toward the future and funding for future years. Mr. Brockway had proposed the following funding picture for lifting reentry work: \$17 million for FY68, \$38 million for FY69, \$67 million for FY70, \$32 million for FY71, and \$7 million for FY72. This, of course, was a very, very preliminary "guesstimate" of future needs. It was quite clear, however, that Mr. Kirk and Mr. Brockway were both keenly interested in the future of maneuverable spacecraft and that they were willing to support their convictions by fighting to get appropriate funding to pursue proper development in this area. On July 26, Colonel Scoville met with members of the AFSC staff to discuss the 461/PRIME launch pad conflict. This was as a result of some further anticipated slippage in the 461 launch schedule that could increase PRIME costs by \$2 million. One possibility suggested by the AFSC staff was to cancel the third 461 launch if the second launch was successful. The whole problem continued to be worked at all levels.<sup>44</sup> On a happier note, testers completed a successful parachute drop on July 28 from an altitude of 45,000 feet; a waiting Lockheed C-130 Hercules successfully snatched the chute in mid-air, a good omen for the future.

The weight of the SV-5D was 858 pounds at the end of July and it looked as if the lift-off weight would be very near this value. Monthly expenditure rate in July dropped to \$1 million, giving a total contract cost of \$37.8 million. Martin staff on the project dropped to 385. By the first of August, all subsystems were checked out in the SV-5D and the first combined systems check was run. On August 2, the second completely successful verification

test of the parachute was accomplished. This was the second chute, with all design changes, dropped from 45,000 feet. The chute was successfully engaged and boarded by the C-130 at an altitude of 6000 feet. Captain I. J. Gennaci again visited Goodyear in Phoenix. A review of the manufacturing and configuration control procedures revealed that, at last, Goodyear was placing considerable emphasis on providing a high quality product. Honeywell planned to complete testing on the flight guidance at the plant and then ship it to Baltimore for installation into FV-1 prior to the shock and vibration tests. The FV-2 structure and heat shield were completed by early August and equipment was being installed as it became available. It would go into the acceptance test facility as soon as FV-1 left.<sup>45</sup>

As the summer of 1966 slipped by, PRIME edged onwards towards flight. Brockway called on August 11 and informed the office that the funding for the START line item to include PILOT had been approved by Dr. John S. Foster, the DDR&E, as follows: \$10 million for FY68, \$20.5 million for FY69, \$71 million for FY70, \$43.5 million for FY71, and \$15.5 million for FY72. Requests for extensions to the PRIME and PILOT programs per se had been disapproved. The FY68 effort was to be devoted to system definition and configuration development of a larger unmanned autonomous vehicle with hardware procurement planned in FY69 and beyond.<sup>46</sup> By mid-August the PRIME project office had received some indication that program 461 might slip some more so that PRIME could not get on the pad until early October. The impact on PRIME was being evaluated and preliminary analysis indicated it could cause an additional increase in program cost of \$300,000.<sup>47</sup> The August Management Review was held at SSD on August 19. Problems at the head of the list were again the guidance system, the electrical interface connectors and the recovery system drop schedule. Additional tests and analysis revealed that the electrical connectors currently installed in FV-1 would have to be replaced prior to flight. The flight guidance system was now due in Baltimore on

August 30, and recovery systems drop tests would not be completed until October 15. An approach to resolving each of these problems was established at the Management Review; everyone left with a clear understanding as to what needed to be done. On another matter, attendees decided that the most expedient and reliable means of shipping the SV-5Ds to Vandenberg for launch was by the American Airlines Freight System, for shipment would take less than 24 hours.<sup>48</sup>

Final resolution of PRIME development concerns began at the end of August. A meeting was held at Honeywell on August 29-31, with the guidance system being thoroughly reviewed by Colonel Scoville, Buz Hello, and senior Honeywell technical and management staff. The Aerospace Corporation (in a rare appearance), as well as Air Force representatives from other SSD offices, were also in attendance. Examination and revision of the predicted vibration environment within the PRIME vehicle during flight resulted in a lowering of vibration levels for the guidance system qualification testing, resolving what had been the major problem with system testing and checkout. The unit to be placed into FV-1 for flight would be at Martin by September 15. No launch date delays were anticipated as a result of careful rescheduling of testing on FV-1. The recovery system experienced two successful low-altitude drops on August 20, a bit of needed and encouraging news. Another high-altitude drop test of the recovery system was conducted on September 7 at El Centro and met with equal success. The Beneficial Occupancy Data (BOD) of October 5 continued to look good in early September so the launch was then scheduled for December 13. Progress toward that date looked hopeful.

## NOTES

1. PRIME Management Report, Colonel C. L. Scoville, Director, Program START, and Capt J. L. Vitelli, Project Officer, September 1967, pp 12-13.
2. Minutes of October PRIME Management Review, October 1965.
3. PRIME Management Report, Colonel C. L. Scoville, Director, Program START, and Capt J. L. Vitelli, Project Officer, September 1967, p. 11.
4. Ibid., p. 15.
5. Ibid., pp 6-8.
6. Ibid., pp 7-8.
7. Ibid.
8. Ibid.
9. Ibid., p. 14.
10. Ibid., pp 8-9.
11. Minutes of November PRIME Management Review, November 1965.
12. Msg, SSTP-33700, SSD to AFSC, 26 October 1965.
13. Ltr, Colonel E. A. Hawkins, Deputy Director of Science and Technology, Hq USAF, to AFSC (MSF), 19 October 1965, subj: START Program Studies.
14. Minutes of PRIME Project Critical Design Review, Martin Company Report, CR-293.
15. Ltr, General Funk, Commander SSD, to Dr. I. Getting, President, Aerospace Corporation, 9 November 1965, subj: Phase-Out of Aerospace GSE/TD on the START Program.
16. Msg, MSFU-39669, AFSC to SSD, 5 November 1965.
17. Ltr, Colonel J. R. Hood, Asst Deputy for Technology, SSD, to AFSC (MSF), 7 December 1965, subj: START Development Plan, December 1965.
18. Memo for Record, Major R. Gerzine, 17 December 1965, subj: Trip Report to Washington, D.C. - Briefing to Mr. Fink, DDR&E, on ARIS Requirements for START.

19. Memo, Dr. J. S. Foster, DDR&E, to Dr. Harold Brown, Secretary of the Air Force, 4 January 1966, subj: Approval of USAF FY66 RDT&E Spacecraft Technology and Advanced Reentry Tests (START) Program.
20. Determinations and Findings, D&F 66-11c-82, Management Report No. P-66-1-680A, 4 January 1966.
21. Formal submittal of information for General Funk's weekly staff meeting, submittal by Colonel Scoville, 17 January 1966.
22. Minutes of January PRIME Management Review, January 1966.
23. Ibid.
24. Martin Company ltr, MT-0143, to Colonel Scoville, 18 February 1966, subj: Problem Summary Report.
25. Minutes of February PRIME Management Review, February 1966.
26. Msg, MSFU-14074, AFSC to SSD, 15 February 1966.
27. Informal Report, SSTRS, Significant Events, 17 March 1966.
28. Msg, SCCPS-16848, AFSC to SSD, 15 March 1966.
29. Ltr, L. S. Rochte, Deputy for Technology, SSD to General Funk, Commander, SSD, 24 March 1966, subj: Programs 461/PRIME Launch Pad Conflict.
30. Minutes of April PRIME Management Review, April 1966.
31. PRIME Management Seminar, Martin Report, ER 13875-11, April 1966.
32. Formal submittal of information for General Funk's weekly staff meeting, submitted by Colonel Scoville, 9 May 1966.
33. Ltr, Colonel N. J. Keefer, Director of Research and Technology, to Colonel L. S. Rochte, Deputy for Technology, SSD, 20 May 1966, subj: PRIME Recovery Subsystem.
34. Minutes of May PRIME Management Review, May 1966.
35. PRIME Management Seminar, Martin Report, ER 13875-12, May 1966.
36. Informal Report, SSTRS, Significant Events, 21 June 1966.
37. Minutes of June PRIME Management Review, June 1966.

38. PRIME Management Seminar, Martin Report, ER 13875-13, June 1966.
39. Informal Report, SSTRS, Significant Events, 30 July 1966.
40. Formal submittal of information for General Funk's weekly staff meeting, submitted by Colonel Scoville, 11 July 1966.
41. Ltr, Colonel D. D. McKee, Deputy for Unmanned Systems, and Colonel L. S. Rochte, Deputy for Technology, to General B. I. Funk, Commander, SSD, 15 July 1966, subj: Programs 461/PRIME Launch Pad Conflict.
42. Msg, SSGV-00078, SSD to AFSC, 15 July 1966.
43. Minutes of July PRIME Management Review, July 1966.
44. Memo for Record, Colonel C. L. Scoville, 29 July 1966, subj: Trip to Baltimore/Washington 24-27 July 1966.
45. PRIME Management Seminar, Martin Report, ER 13875-14, July 1966.
46. Memo for Record, Lt Colonel J. R. Evans, 12 August 1966, subj: DDR&E Verbal Guidance of 11 August 1966.
47. Formal submittal of information for General Funk's weekly staff meeting, submitted by Colonel C. L. Scoville, 15 August 1966.
48. Minutes of August PRIME Management Review, August 1966.

## CHAPTER V

### PRIME FLIES

By mid-September 1966 FV-1's guidance unit had been delivered to Martin and was being installed. Subsystem checkout would follow, but qualification testing would extend past the end of the month. The electrical connectors in FV-1 were changed out while the guidance system was replaced. Three more successful recovery system drop tests permitted the program office to breathe a little easier with respect to that long-plagued system. It also looked as if the needed ARIS ship would be on station for support of PRIME on December 13. The PRIME program office gave top priority and attention to the qualification testing taking place at Honeywell. This was the most critical problem at the time and its progress was being watched almost hourly by Captain John Dobby, the project officer responsible for the design and development of this important subsystem. By September 28 some additional problems arose that delayed qualification testing completion a few more days. The real problem surfacing now involved the guidance ground equipment used by Honeywell. Vandenberg needed it so that it could be used for the final checkout of FV-1 prior to launch; it had to be shipped the first week in October.

SSD held the last PRIME Management Review at Baltimore on September 20, and it was a litany of accomplishments. The first booster was to be shipped to Vandenberg on September 29. All the problem areas seemed to be under control; there was absolutely no room in the schedule for any additional problems, or so it seemed. Lieutenant Colonels Copeman (office of primary responsibility at Air Force headquarters) and E. L. McCabe (primary responsibility at AFSC) and a representative of Honeywell were also in attendance at this Management Review.<sup>1</sup>

Martin had worked superbly to ensure the guidance system would be ready for PRIME's first flight. During the 206 working days from the beginning of the year to the end of September, Martin had sent technical and management personnel to Honeywell on 142 days. This was over and above the Martin quality control personnel who were permanently stationed at Honeywell. Martin had appointed a technical subcontract manager for Honeywell, hired a technical consultant from the Massachusetts Institute of Technology, and conducted internal detailed design reviews involving not only Baltimore non-project people, but also experts from the Denver and Canaveral Divisions, as well as corporate officers and staff engineers. The problem was worked at the top management levels at Martin and Honeywell. The Martin Company did everything possible to assure the Air Force that its first lifting body would not suffer from lack of an excellent guidance system. Qualification testing of the guidance system was completed on October 3. The guidance ground equipment was shipped to Vandenberg on October 7. In early October some contaminants were found in one of the electrical interface connectors and as a result the connectors in FV-1 were suspect; Martin recommended disassembling those in FV-1 for inspection. The Air Force concurred, concluding there was enough evidence to warrant the use of the time and money to perform this inspection. It was therefore scheduled and FV-1 delivery slipped from November 2 to November 9. A 7-day week, 24-hour day schedule was now in effect in the ATF at Martin-Baltimore. Captain Vitelli, the Air Force representative of the project office, was dispatched to Martin-Baltimore on October 20 and remained there until FV-1 was shipped to Vandenberg. The spirit, desire, and exceptionally high performance of the Martin test team in the acceptance test facility during those long hours in the fall of 1966 would be difficult to achieve again. Some underlying force must have been driving those individuals, who, for weeks at a time, would see very little



of their families. This was certainly a tribute to the fine leadership displayed by Martin, and the esprit of the company's workers.

The vibration Combined Systems Tests were completed on October 26 and the SV-5D was weighed and balanced on October 27. On October 28 an anomaly was found in the guidance programer which caused a lot of headaches. It could not be made to repeat itself and trouble shooting continued unsuccessfully until November 8 when the trouble shooting was transferred to FV-2 to which power had been applied in another area of the Martin plant. On November 2 the First Article Configuration Inspection (FACI) was conducted by the Air Force and the baseline configuration was established. A successful acceptance test was run of FV-1 on November 8. On November 11 FV-1 left Friendship Airport \* south of Baltimore for the west coast on an American Airlines freighter.

Even at this stage, small but potentially serious problems showed up. In late October some random failures of the separation bolts to break on being detonated caused immediate concern; three bolts had failed to break during systems tests, and with the spectre of SV-5 plummeting earthward still attached to its interstage, engineers began an immediate effort to ensure the bolts installed were flaw-free. The delivery of the interstage and "mating" went smoothly. The interstage and shroud were delivered to Vandenberg on November 1, and mated to the erected booster on November 3-4. Colonel Scoville and representatives of the START program office, Martin Company, 6595th ATW, and the Aerospace Corporation went downrange to the terminal site to check on the preparedness of that area for the launch. On November 12, FV-1 was mated to the booster and power was applied by November 14. Qualification of the electrical connectors was

---

\*Now Baltimore-Washington International.

finally complete on November 11 and by November 14, 18 explosive bolts had been successfully fired. Two more successful parachute drops were conducted the week of November 9. Everything at last seemed to be functioning like clockwork, but the launch schedule, even now, continued to remain fluid. During the week of November 23, word was received that the ARIS ship would not be able to support a December 13 launch because it was required to support a higher priority program. It looked as if the launch would be delayed to at least December 19. If the ARIS ship was still at Kwajalein on December 3, sailing time and set-up time would generate a day-by-day slip in the PRIME launch, for PRIME needed the ARIS ship near Hawaii for its launches. On December 5 qualification testing of the exploding separation bolts was completed. That same day, SSD announced that the first PRIME launch would slip to at least December 20 because of lack of ship support prior to that time.<sup>2</sup> FV-2 was in the acceptance test facility at Baltimore and final tests and checkout were being completed on schedule. A combined systems test was run on December 15. And then, with long-awaited expectations, PRIME entered its flight test phase.

On December 21, 1966, the first PRIME reentry vehicle was launched on the Western Test Range from Space Launch Complex 3, East Pad, at Vandenberg AFB. The launch was successfully accomplished early in the launch window and on the first launch attempt, still something of a rarity in the mid-1960s. The trajectory simulated a reentry from low-earth orbit with a zero crossrange maneuver. The performance of the booster was excellent. The performance of the SV-5D was superb through the boost and reentry phases resulting in ballute deployment 4300 miles downrange from the launch site and within 900 feet of the preselected target point. The ballute deployed at 99,850 feet altitude, and when the SV-5D had descended to a little less than 45,000 feet, the main 'chute began to deploy, but never completed its extraction sequence. FV-1 fell into the sea. But it was far

from a failure, despite this annoying denouement, so similar to ASSET earlier. Recall that accuracy success would have been achieved anywhere within a 10 nautical mile radius of the target point. All flight objectives were unquestionably accomplished except for vehicle recovery. Over 90 percent of the possible telemetry data was received for flight evaluation. The flight occurred within a month of the launch date established in November 1964 and the vehicle lifted off at 895 pounds, about 4 percent below the weight goal established early in the program. An extremely well written flight report has been published by Martin and further narrative of the flight will not be contained herein. Needless to say, it was only a few hours after the launch that analyses were underway regarding the cause of the failure. Analysis showed that the ballute was disconnected and the sequence for deployment of the main chute did begin; however, the main chute was never pulled from its container and the vehicle impacted the ocean at a high speed. Premature power shut-down on the vehicle disabled the flaps which were required for vehicle stabilization during deceleration. Again, a complete report of the causes of the failure of vehicle recovery were contained in the Martin flight report.<sup>3</sup>

Although the SV-5D was not recovered, the following significant accomplishments resulted from the successful flight of FV-1:

- PRIME demonstrated for the first time that lifting body reentry technology and techniques developed by extensive ground testing were valid in actual flight. FV-1's flight performance matched predicted performance values well.

- It was demonstrated that the systems developed for PRIME were capable of precision accuracy in guiding the SV-5D to a pre-selected point - an important result not only for research validation purposes, but also with implications for any future operational data return system as well.

- SV-5D demonstrated stable and controllable hypersonic and supersonic flight characteristics.

- Ablation effects on vehicle performance and stability during hypersonic/supersonic flight were small for this type of heat shield.

- PRIME experienced minimal blackout effects, and showed little contamination effects on its ablative thermal protection system.

- A wealth of hypersonic reentry technology data was obtained, all of high quality, including measurements of ablation rates and behavior characteristics of the thermal protection system.

The second PRIME booster was erected at Vandenberg on January 9, 1967. FV-2 progressed through the final stages of acceptance and the final ground test was run on January 16. The shroud and interstage had been delivered to Vandenberg on January 14. FV-2 was shipped from Baltimore on January 19 and was mated to the booster on January 20 in preparation for applying power. FV-3 moved into the acceptance test facility in Baltimore to begin its test and checkout.<sup>4</sup> But this was the good news. Overall, the year began with some financially unattractive requests. Overruns of contract funding were reported by Convair and Martin in December 1966. A request was made on January 9 to fund a Convair overrun of \$455,000. The major causes of this problem were increased rates, material and subcontract costs in excess of those estimated at negotiations, and the technical problems during development and testing which required greater effort than was planned. Brigadier General Paul T. Cooper (who replaced General Funk as Commander, SSD, in the fall) approved the request on January 13. He was also notified on January 18 of a potential cost overrun with Martin of about \$2.4 million. The causes were similar to those at Convair. The funding situation was a subject of the January Quarterly Review at SSD. Colonel Scoville reminded the AFSC staff that \$1.85 million had been requested previously for FY67 (\$500,000 which was diverted to PILOT in FY66 to be

returned to PRIME in FY67 and \$1.35 million because of the pad conflict). In order to relieve this requirement, the AFSC staff stated they would request the Atlas office to defer receipt of \$2.0 million in boosters to July 1967 when FY68 monies would become available. This action was taken.<sup>5</sup>

By mid-January, the ship support for the February 21 launch did not look encouraging. The first Apollo mission was scheduled for the same day and this, of course, was expected to impact on PRIME. The terrible Apollo fire disaster on January 27 resulted in a reschedule of the ship support so by the end of January support for PRIME looked good, but this would change soon enough.\* On February 7 a message was dispatched to AFSC headquarters concerning PRIME project funding for FY67 and FY68. PRIME requirements for FY67 were \$16.85 million and \$15 million was authorized. This, as mentioned above, was solved by deferring booster costs of \$2 million to FY68. The best estimate for FY68 requirements at this time was \$8.1 million to include the booster costs, incentive fees and overruns which had been recently announced. The line item for START carried only \$5 million at the time. Of the \$8.1 million required for PRIME, \$6.9 million was required in July 1967 to pay old bills. Additional funds had to be available for PRIME in FY68. Furthermore, based on the wealth of data already gained by the first flight, it was recommended to AFSC headquarters that an additional \$975,000 be added to the PRIME budget to complete two technology tasks. These were first, an analysis of spacecraft systems performance and reusability data which would be gained from a recovered SV-5D. This would involve returning a recovered SV-5D to the Martin acceptance test facility for

---

\*This was the tragic Apollo 1 (Apollo 204) mission, scheduled as a 14-day manned demonstration and checkout of the Apollo vehicle. On January 27, 1967, a pad fire at the Cape destroyed the spacecraft and killed astronauts Virgil "Gus" Grissom, Edward White, and Roger Chaffee. The first manned Apollo mission was Apollo 7, October 11-22, 1968, commanded by Walter Schirra.

detailed internal and external inspection, a complete flight simulation test and subsystem functional tests to determine performance of subsystems and possible reusability of spacecraft and typical subsystems. Secondly, Martin would undertake additional analysis to expand and improve the aerodynamic technology gained from the PRIME flights. This study would enhance the information gained from the PRIME flights and enable a better design of future lifting body spacecraft. Immediate authorization to proceed with these tasks was requested.<sup>6</sup>

During the week of February 8 the Eastern Test Range (ETR) notified SSD that the Advanced Range Instrumentation Ship (ARIS) would not be available for PRIME until February 27; so immediate action was taken to reschedule the PRIME flight. During the week of February 15 the earliest date for PRIME ARIS ship support moved to March 4. The Western Test Range (WTR) therefore rescheduled all support for PRIME to March 4 and the flight continued to be delayed due to ship support. FV-2 was proceeding through its test and checkout at the pad on schedule. A series of minor problems were had with the programmer, attitude reference package, and the autopilot, and these were replaced as a safety precaution. In some cases, the new units came out of FV-3 in Baltimore and this, of course, gave the test team in the acceptance test facility their headaches.<sup>7</sup> At the end of February the second PRIME launch was still scheduled for March 4. All range support facilities such as ships and planes were moving to their stations. Reports from the terminal site indicated that they would support the Saturday launch. FV-2 was being checked out on schedule. A potential scheduling problem existed with the Maneuverable Ballistic Reentry Vehicle (MBRV) program which required the ARIS ship and the Range Tracker ship on a location about five days away from the PRIME location on March 7, 1967. Meetings were held with Ballistic Systems Division to make arrangements to allow PRIME to launch on March 4 as scheduled, before MBRV.<sup>8</sup> Nevertheless, PRIME slipped a day.

the end of the month. There was also an increase in activity in the SV-5D Acceptance Test Facility (ATF) in Baltimore directed toward the checkout of all the ground equipment to be used in the testing and checkout of the SV-5D. The weight of the SV-5D stood at 859 pounds at the end of April. The monthly expenditure rate on the Martin contract during the Spring of 1965 was about \$1.7 million. The actual funding liability was at \$33.4 million with a projected value of \$45.3 million at completion. A total of 662 men were working on the PRIME project at Martin in April. The maximum had been reached in November at 759 men.<sup>31</sup>

Establishing a first flight date remained a nebulous business. The START program office completed a schedule/cost study in early May which indicated that a November 23 launch date could still be achieved assuming availability of the pad by September 20, 1966. The cost to the program would increase, however, due to the compressed pad activation schedule, and would be about \$700,000. (If the launch were slipped to January 1967, the increased program cost would be at least \$1 million, assuming the final launch would be in July 1967). The least expensive approach would be to launch about mid-December with pad availability on September 20. The final decision would still be made in June although analysis would continue.<sup>32</sup>

Problems continued with the recovery system in May, particularly with air pickup loads and packing density of the main chute. The loads imposed on the chute during recovery had on two occasions ripped the cone out of the main chute. Action was being taken to strengthen the chute suspension lines, to increase the elasticity of the suspension lines, and to provide a snubber device in both the aircraft and the cone to reduce the loads on the chute. The packing density was already very high and increasing the strength of the suspension lines would compound the problem. A solution, of course, was to reduce the size of the

chute. The descent rate had been limited to 25 fps but the recovery forces agreed to an increase to 27 fps allowing a decrease in chute diameter to something less than 48 feet. Tests on these new chutes would take place in June.<sup>33</sup> By mid-May, FV-1 was approaching the final stages of fabrication. The nose section and aft body section were contoured and structurally complete. The equipment beam was installed on the aft body although several pieces of hardware were still missing. There were two processes that seemed to slow the final heat shield fabrication. Martin had trouble getting the honeycomb bonded to the fin substrate and, secondly, getting a good fit of heat shield protective edge members was profoundly difficult. Honeywell was working 7-day weeks and 24-hour days on the guidance system and it looked like a late May delivery date for the FV-1 units. Vibration qualification tests on the guidance system were causing most of the problems during May. Most of the subsystems were having problems but the major problems were unquestionably in the guidance and recovery subsystems. The separation system also presented its share of headaches. The explosive bolts presented a major concern. It seemed to be impossible to design a highly reliable explosive bolt that stayed under shock limitations delivered at separation. Convair had planned a method of attacking this problem and made an outstanding effort to find a bolt to do the job within the time remaining.

At the May PRIME Management Review, Colonel Scoville emphasized cost and stated that there was essentially no money remaining to solve problems. Engineers would have to devise economical methods to solve the current problems and not risk the success of the mission. The objective was still a September delivery of FV-1 and a November 23 launch date. Solutions to problems had to be decided on quickly so that immediate action could be taken. Time was running out.<sup>34</sup> By the end of May, the Baltimore Acceptance Test Facility (ATF) was ready for FV-1 and a SV-5D ground test article was being used to check out handling procedures. The vehicle's weight stood at 856 pounds. The command buffer unit was



delivered at Kwajalein and installation was underway. The expenditure at Martin in May was \$2.2 million against a planned \$2.0 million. Total staff on the project had, however, dropped to 562.<sup>35</sup>

On June 19, 1966 FV-1 was moved into the Acceptance Test Facility to begin the long series of tests that would prepare it for the Air Force acceptance. Everything was not completely smooth at this time with FV-1 however. The men of the Martin acceptance test team headed by Messrs. Dan Weller and Al Ryan would have a difficult job ahead. Air conditioners required to cool the vehicle whenever power was applied were old government surplus items that broke down quite frequently. It was difficult to keep one of the two operative at all times. A new air conditioner was ordered for July delivery. The guidance system in FV-1 at the time was not in flight unit and had to be changed. About 11 pressure transducers were unavailable for installation in the nose section and would have to be installed on a non-interference basis. Spares were never in abundance, it seemed -- certainly a schedule "buster" when testing begins. A major milestone was reached when the flaps were installed, fitted, and were made to work properly.

June brought mixed results on the recovery system development scene. Two drops at high dynamic pressure (45,000 feet, Mach .6) of the main parachute were made on June 6, and the parachute was successfully recovered. Two additional drops were scheduled on June 16 and 17, 1966 with the intent of completing the development and verification testing at that time. Unfortunately, the cone on the first of these drops did not erect properly. Analysis of the recovered parachute revealed that some of the lines had been improperly stitched and had torn out on deployment; obviously, quality control problems were continuing. The manufacturing method was immediately corrected to solve this problem.<sup>36</sup> During

the June Management Review, then, the recovery system naturally was one of the problem areas discussed. Everyone was anxious to be able to end development testing, and Martin insisted that the criteria would be two consecutive successful drops on one chute design. Bastian "Buz" Hello, who replaced Joe Putegnat as Martin's Program Manager in early spring, promised that if problems then arose during production chute drops, the development effort would commence again. Hello, a no-nonsense and extremely competent engineer, had worked in the aerospace field since the days of America's first combat-worthy jet fighter, the Lockheed XP-80. Colonel Scoville agreed to this but insisted that two or three high dynamic pressure drops be among the first production chute drops. The production rate of parachutes was now the problem. At the outset, only two chutes could be fabricated per week; later, the rate would increase to eight. The projected delivery date for FV-1 still remained at September 23, 1966 even though FV-1 would reach the acceptance test facility six weeks late, necessitating a second shift and weekend work to meet the schedule.<sup>37</sup> June closed with the SV-5D weighing 858 pounds. Martin's monthly expenditure rate dropped to \$1.2 million in June, and the total personnel on the project continued to decline to 531. The total money expended by Martin on PRIME to date was about \$36.8 million.<sup>38</sup>

In late June, a key review team inspected PRIME facilities in the Pacific. A group consisting of Colonels L. S. Rochte, Norman J. Keefer, and C. L. Scoville visited the PRIME terminal site at Kwajalein and Roi Namur during the week of June 27, 1966 to assess its progress towards the upcoming SV-5 flights. The trip was very worthwhile in permitting a good crossflow of information between the several agencies involved in support of the PRIME project. They were briefed by the Army at Kwajalein and by the Massachusetts Institute of Technology (MIT) people on Roi Namur. As a result of this trip, confidence was increased in the effectiveness of the set-up in the terminal area. During this

same trip described above, the PRIME team met with the recovery forces at Hickam, Hawaii for a briefing on recovery force operations. Disturbingly, a test of the main chute on June 30 failed miserably. The cone did not deploy, and for a variety of reasons, recovery could not be attempted. Inspectors examined the chute after ground impact and found that one cutter on the cone bag had fired but did not cut the line completely; the lanyard for the second cutter ripped off before the second cutter fired.<sup>39</sup> On July 5 another chute was dropped. The cone deployed and upon aerial snatch of the chute the load lines in the cone broke. A design meeting was held immediately.

In early July, \$15 million was released to the START program office for application to the PRIME project. The other \$1 million programmed for START was released directly to ASD for use on the PILOT project.<sup>40</sup> On July 15, General Paul T. Cooper, SSD Vice Commander, was briefed on the continuing PRIME/461 pad conflict. It was recommended that 461 be completed as expeditiously as possible which would be a final launch on September 26. PRIME would then take over the pad and could be ready to launch on December 6, 1966. This, however, would require a second shift and some overtime work resulting in a total cost increase to PRIME slightly in excess of \$1 million.<sup>41</sup> Following the briefing, General Cooper signed a message to AFSC that the PRIME Beneficial Occupancy Date (BOD) had slipped from August 8 to September 27 and that by careful planning the slip in the first PRIME launch would be only two weeks. AFSC responded to the message and requested that the Program Directors discuss the details with the AFSC staff in Washington. This meeting took place on July 26 and essentially the same briefing was given that had been delivered to General Cooper. Following this meeting, AFSC requested that SSD study several alternatives to the SSD recommendation and present the results at the Quarterly Review at SSD on August 22 and 23.<sup>42</sup>

The July Management Review was held at Vandenberg to familiarize the management group with the operations of that facility as well as to provide an opportunity for top level Vandenberg personnel to become familiar with the PRIME project and its present status. The monthly PRIME Management Review was held at Vandenberg AFB on July 20. Colonel Scoville announced the change in launch dates and also that FV-1 delivery would now move from September 23 to October 17. He asked that Martin make use of this additional time by working to make FV-1 a more reliable flight article and by reducing program cost. This would be done by adding or modifying test plans to increase the confidence level in FV-1 and to eliminate, as much as possible, overtime and weekend premium labor to reduce cost. Convair was similarly directed. The revised launch schedule anticipated PRIME launches on December 6, 1966 and February 21, April 18, and June 20, 1967. FV-1 was moving through subsystem checkouts and was about 90 percent complete by the end of July. After the subsystems checkout, a series of combined systems tests (CST) would lead up to vehicle acceptance. This series consisted of a first CST, an EMI CST (a check for electromagnetic interference), a shock CST (to simulate separation shock), vibration CSTs (simulating launch and reentry vibration in three axes), and finally the acceptance CST. Problems at the management review were in the areas of guidance, recovery, separation system delivery schedule, and electrical connectors, but all seemed as though they were manageable. PRIME was beginning to come together nicely.<sup>43</sup>

Colonel Scoville journeyed to Washington and Baltimore on July 24-27 to attend meetings at the Pentagon, AFSC headquarters, and to review the progress on PRIME at Martin. The purpose of the Pentagon meeting was to inform John Kirk, Assistant Director for Space Technology, and Daniel J. Brockway of current information on the status of PRIME and any conflicts that might impact PRIME's funding requirements. Colonel Scoville lead off by reviewing program objectives. Mr. Kirk replied that although there was some

interest in future manned applications he felt that the Director of Defense Research and Engineering (DDR&E) did not desire to change the program objectives. He emphasized the position taken during Secretary of Defense Robert McNamara's recent trip to Los Angeles to review MOL and commented that further emphasis on SV-5's manned application would not be possible - i.e., desirable - at this time. Next, the discussion turned toward the future and funding for future years. Mr. Brockway had proposed the following funding picture for lifting reentry work: \$17 million for FY68, \$38 million for FY69, \$67 million for FY70, \$32 million for FY71, and \$7 million for FY72. This, of course, was a very, very preliminary "guesstimate" of future needs. It was quite clear, however, that Mr. Kirk and Mr. Brockway were both keenly interested in the future of maneuverable spacecraft and that they were willing to support their convictions by fighting to get appropriate funding to pursue proper development in this area. On July 26, Colonel Scoville met with members of the AFSC staff to discuss the 461/PRIME launch pad conflict. This was as a result of some further anticipated slippage in the 461 launch schedule that could increase PRIME costs by \$2 million. One possibility suggested by the AFSC staff was to cancel the third 461 launch if the second launch was successful. The whole problem continued to be worked at all levels.<sup>44</sup> On a happier note, testers completed a successful parachute drop on July 28 from an altitude of 45,000 feet; a waiting Lockheed C-130 Hercules successfully snatched the chute in mid-air, a good omen for the future.

The weight of the SV-5D was 858 pounds at the end of July and it looked as if the lift-off weight would be very near this value. Monthly expenditure rate in July dropped to \$1 million, giving a total contract cost of \$37.8 million. Martin staff on the project dropped to 385. By the first of August, all subsystems were checked out in the SV-5D and the first combined systems check was run. On August 2, the second completely successful verification

test of the parachute was accomplished. This was the second chute, with all design changes, dropped from 45,000 feet. The chute was successfully engaged and boarded by the C-130 at an altitude of 6000 feet. Captain I. J. Gennaci again visited Goodyear in Phoenix. A review of the manufacturing and configuration control procedures revealed that, at last, Goodyear was placing considerable emphasis on providing a high quality product. Honeywell planned to complete testing on the flight guidance at the plant and then ship it to Baltimore for installation into FV-1 prior to the shock and vibration tests. The FV-2 structure and heat shield were completed by early August and equipment was being installed as it became available. It would go into the acceptance test facility as soon as FV-1 left.<sup>45</sup>

As the summer of 1966 slipped by, PRIME edged onwards towards flight. Brockway called on August 11 and informed the office that the funding for the START line item to include PILOT had been approved by Dr. John S. Foster, the DDR&E, as follows: \$10 million for FY68, \$20.5 million for FY69, \$71 million for FY70, \$43.5 million for FY71, and \$15.5 million for FY72. Requests for extensions to the PRIME and PILOT programs per se had been disapproved. The FY68 effort was to be devoted to system definition and configuration development of a larger unmanned autonomous vehicle with hardware procurement planned in FY69 and beyond.<sup>46</sup> By mid-August the PRIME project office had received some indication that program 461 might slip some more so that PRIME could not get on the pad until early October. The impact on PRIME was being evaluated and preliminary analysis indicated it could cause an additional increase in program cost of \$300,000.<sup>47</sup> The August Management Review was held at SSD on August 19. Problems at the head of the list were again the guidance system, the electrical interface connectors and the recovery system drop schedule. Additional tests and analysis revealed that the electrical connectors currently installed in FV-1 would have to be replaced prior to flight. The flight guidance system was now due in Baltimore on

August 30, and recovery systems drop tests would not be completed until October 15. An approach to resolving each of these problems was established at the Management Review; everyone left with a clear understanding as to what needed to be done. On another matter, attendees decided that the most expedient and reliable means of shipping the SV-5Ds to Vandenberg for launch was by the American Airlines Freight System, for shipment would take less than 24 hours.<sup>48</sup>

Final resolution of PRIME development concerns began at the end of August. A meeting was held at Honeywell on August 29-31, with the guidance system being thoroughly reviewed by Colonel Scoville, Buz Hello, and senior Honeywell technical and management staff. The Aerospace Corporation (in a rare appearance), as well as Air Force representatives from other SSD offices, were also in attendance. Examination and revision of the predicted vibration environment within the PRIME vehicle during flight resulted in a lowering of vibration levels for the guidance system qualification testing, resolving what had been the major problem with system testing and checkout. The unit to be placed into FV-1 for flight would be at Martin by September 15. No launch date delays were anticipated as a result of careful rescheduling of testing on FV-1. The recovery system experienced two successful low-altitude drops on August 20, a bit of needed and encouraging news. Another high-altitude drop test of the recovery system was conducted on September 7 at El Centro and met with equal success. The Beneficial Occupancy Data (BOD) of October 5 continued to look good in early September so the launch was then scheduled for December 13. Progress toward that date looked hopeful.

## NOTES

1. PRIME Management Report, Colonel C. L. Scoville, Director, Program START, and Capt J. L. Vitelli, Project Officer, September 1967, pp 12-13.
2. Minutes of October PRIME Management Review, October 1965.
3. PRIME Management Report, Colonel C. L. Scoville, Director, Program START, and Capt J. L. Vitelli, Project Officer, September 1967, p. 11.
4. Ibid., p. 15.
5. Ibid., pp 6-8.
6. Ibid., pp 7-8.
7. Ibid.
8. Ibid.
9. Ibid., p. 14.
10. Ibid., pp 8-9.
11. Minutes of November PRIME Management Review, November 1965.
12. Msg, SSTP-33700, SSD to AFSC, 26 October 1965.
13. Ltr, Colonel E. A. Hawkins, Deputy Director of Science and Technology, Hq USAF, to AFSC (MSF), 19 October 1965, subj: START Program Studies.
14. Minutes of PRIME Project Critical Design Review, Martin Company Report, CR-293.
15. Ltr, General Funk, Commander SSD, to Dr. I. Getting, President, Aerospace Corporation, 9 November 1965, subj: Phase-Out of Aerospace GSE/TD on the START Program.
16. Msg, MSFU-39669, AFSC to SSD, 5 November 1965.
17. Ltr, Colonel J. R. Hood, Asst Deputy for Technology, SSD, to AFSC (MSF), 7 December 1965, subj: START Development Plan, December 1965.
18. Memo for Record, Major R. Gerzine, 17 December 1965, subj: Trip Report to Washington, D.C. - Briefing to Mr. Fink, DDR&E, on ARIS Requirements for START.



19. Memo, Dr. J. S. Foster, DDR&E, to Dr. Harold Brown, Secretary of the Air Force, 4 January 1966, subj: Approval of USAF FY66 RDT&E Spacecraft Technology and Advanced Reentry Tests (START) Program.
20. Determinations and Findings, D&F 66-11c-82, Management Report No. P-66-1-680A, 4 January 1966.
21. Formal submittal of information for General Funk's weekly staff meeting, submittal by Colonel Scoville, 17 January 1966.
22. Minutes of January PRIME Management Review, January 1966.
23. Ibid.
24. Martin Company ltr, MT-0143, to Colonel Scoville, 18 February 1966, subj: Problem Summary Report.
25. Minutes of February PRIME Management Review, February 1966.
26. Msg, MSFU-14074, AFSC to SSD, 15 February 1966.
27. Informal Report, SSTRS, Significant Events, 17 March 1966.
28. Msg, SCCPS-16848, AFSC to SSD, 15 March 1966.
29. Ltr, L. S. Rochte, Deputy for Technology, SSD to General Funk, Commander, SSD, 24 March 1966, subj: Programs 461/PRIME Launch Pad Conflict.
30. Minutes of April PRIME Management Review, April 1966.
31. PRIME Management Seminar, Martin Report, ER 13875-11, April 1966.
32. Formal submittal of information for General Funk's weekly staff meeting, submitted by Colonel Scoville, 9 May 1966.
33. Ltr, Colonel N. J. Keefer, Director of Research and Technology, to Colonel L. S. Rochte, Deputy for Technology, SSD, 20 May 1966, subj: PRIME Recovery Subsystem.
34. Minutes of May PRIME Management Review, May 1966.
35. PRIME Management Seminar, Martin Report, ER 13875-12, May 1966.
36. Informal Report, SSTRS, Significant Events, 21 June 1966.
37. Minutes of June PRIME Management Review, June 1966.

38. PRIME Management Seminar, Martin Report, ER 13875-13, June 1966.
39. Informal Report, SSTRS, Significant Events, 30 July 1966.
40. Formal submittal of information for General Funk's weekly staff meeting, submitted by Colonel Scoville, 11 July 1966.
41. Ltr, Colonel D. D. McKee, Deputy for Unmanned Systems, and Colonel L. S. Rochte, Deputy for Technology, to General B. I. Funk, Commander, SSD, 15 July 1966, subj: Programs 461/PRIME Launch Pad Conflict.
42. Msg, SSGV-00078, SSD to AFSC, 15 July 1966.
43. Minutes of July PRIME Management Review, July 1966.
44. Memo for Record, Colonel C. L. Scoville, 29 July 1966, subj: Trip to Baltimore/Washington 24-27 July 1966.
45. PRIME Management Seminar, Martin Report, ER 13875-14, July 1966.
46. Memo for Record, Lt Colonel J. R. Evans, 12 August 1966, subj: DDR&E Verbal Guidance of 11 August 1966.
47. Formal submittal of information for General Funk's weekly staff meeting, submitted by Colonel C. L. Scoville, 15 August 1966.
48. Minutes of August PRIME Management Review, August 1966.

## CHAPTER V

### PRIME FLIES

By mid-September 1966 FV-1's guidance unit had been delivered to Martin and was being installed. Subsystem checkout would follow, but qualification testing would extend past the end of the month. The electrical connectors in FV-1 were changed out while the guidance system was replaced. Three more successful recovery system drop tests permitted the program office to breathe a little easier with respect to that long-plagued system. It also looked as if the needed ARIS ship would be on station for support of PRIME on December 13. The PRIME program office gave top priority and attention to the qualification testing taking place at Honeywell. This was the most critical problem at the time and its progress was being watched almost hourly by Captain John Dobby, the project officer responsible for the design and development of this important subsystem. By September 28 some additional problems arose that delayed qualification testing completion a few more days. The real problem surfacing now involved the guidance ground equipment used by Honeywell. Vandenberg needed it so that it could be used for the final checkout of FV-1 prior to launch; it had to be shipped the first week in October.

SSD held the last PRIME Management Review at Baltimore on September 20, and it was a litany of accomplishments. The first booster was to be shipped to Vandenberg on September 29. All the problem areas seemed to be under control; there was absolutely no room in the schedule for any additional problems, or so it seemed. Lieutenant Colonels Copeman (office of primary responsibility at Air Force headquarters) and E. L. McCabe (primary responsibility at AFSC) and a representative of Honeywell were also in attendance at this Management Review.<sup>1</sup>

Martin had worked superbly to ensure the guidance system would be ready for PRIME's first flight. During the 206 working days from the beginning of the year to the end of September, Martin had sent technical and management personnel to Honeywell on 142 days. This was over and above the Martin quality control personnel who were permanently stationed at Honeywell. Martin had appointed a technical subcontract manager for Honeywell, hired a technical consultant from the Massachusetts Institute of Technology, and conducted internal detailed design reviews involving not only Baltimore non-project people, but also experts from the Denver and Canaveral Divisions, as well as corporate officers and staff engineers. The problem was worked at the top management levels at Martin and Honeywell. The Martin Company did everything possible to assure the Air Force that its first lifting body would not suffer from lack of an excellent guidance system. Qualification testing of the guidance system was completed on October 3. The guidance ground equipment was shipped to Vandenberg on October 7. In early October some contaminants were found in one of the electrical interface connectors and as a result the connectors in FV-1 were suspect; Martin recommended disassembling those in FV-1 for inspection. The Air Force concurred, concluding there was enough evidence to warrant the use of the time and money to perform this inspection. It was therefore scheduled and FV-1 delivery slipped from November 2 to November 9. A 7-day week, 24-hour day schedule was now in effect in the ATF at Martin-Baltimore. Captain Vitelli, the Air Force representative of the project office, was dispatched to Martin-Baltimore on October 20 and remained there until FV-1 was shipped to Vandenberg. The spirit, desire, and exceptionally high performance of the Martin test team in the acceptance test facility during those long hours in the fall of 1966 would be difficult to achieve again. Some underlying force must have been driving those individuals, who, for weeks at a time, would see very little

of their families. This was certainly a tribute to the fine leadership displayed by Martin, and the esprit of the company's workers.

The vibration Combined Systems Tests were completed on October 26 and the SV-5D was weighed and balanced on October 27. On October 28 an anomaly was found in the guidance programer which caused a lot of headaches. It could not be made to repeat itself and trouble shooting continued unsuccessfully until November 8 when the trouble shooting was transferred to FV-2 to which power had been applied in another area of the Martin plant. On November 2 the First Article Configuration Inspection (FACI) was conducted by the Air Force and the baseline configuration was established. A successful acceptance test was run of FV-1 on November 8. On November 11 FV-1 left Friendship Airport \* south of Baltimore for the west coast on an American Airlines freighter.

Even at this stage, small but potentially serious problems showed up. In late October some random failures of the separation bolts to break on being detonated caused immediate concern; three bolts had failed to break during systems tests, and with the spectre of SV-5 plummeting earthward still attached to its interstage, engineers began an immediate effort to ensure the bolts installed were flaw-free. The delivery of the interstage and "mating" went smoothly. The interstage and shroud were delivered to Vandenberg on November 1, and mated to the erected booster on November 3-4. Colonel Scoville and representatives of the START program office, Martin Company, 6595th ATW, and the Aerospace Corporation went downrange to the terminal site to check on the preparedness of that area for the launch. On November 12, FV-1 was mated to the booster and power was applied by November 14. Qualification of the electrical connectors was

---

\*Now Baltimore-Washington International.

finally complete on November 11 and by November 14, 18 explosive bolts had been successfully fired. Two more successful parachute drops were conducted the week of November 9. Everything at last seemed to be functioning like clockwork, but the launch schedule, even now, continued to remain fluid. During the week of November 23, word was received that the ARIS ship would not be able to support a December 13 launch because it was required to support a higher priority program. It looked as if the launch would be delayed to at least December 19. If the ARIS ship was still at Kwajalein on December 3, sailing time and set-up time would generate a day-by-day slip in the PRIME launch, for PRIME needed the ARIS ship near Hawaii for its launches. On December 5 qualification testing of the exploding separation bolts was completed. That same day, SSD announced that the first PRIME launch would slip to at least December 20 because of lack of ship support prior to that time.<sup>2</sup> FV-2 was in the acceptance test facility at Baltimore and final tests and checkout were being completed on schedule. A combined systems test was run on December 15. And then, with long-awaited expectations, PRIME entered its flight test phase.

On December 21, 1966, the first PRIME reentry vehicle was launched on the Western Test Range from Space Launch Complex 3, East Pad, at Vandenberg AFB. The launch was successfully accomplished early in the launch window and on the first launch attempt, still something of a rarity in the mid-1960s. The trajectory simulated a reentry from low-earth orbit with a zero crossrange maneuver. The performance of the booster was excellent. The performance of the SV-5D was superb through the boost and reentry phases resulting in ballute deployment 4300 miles downrange from the launch site and within 900 feet of the preselected target point. The ballute deployed at 99,850 feet altitude, and when the SV-5D had descended to a little less than 45,000 feet, the main 'chute began to deploy, but never completed its extraction sequence. FV-1 fell into the sea. But it was far

from a failure, despite this annoying denouement, so similar to ASSET earlier. Recall that accuracy success would have been achieved anywhere within a 10 nautical mile radius of the target point. All flight objectives were unquestionably accomplished except for vehicle recovery. Over 90 percent of the possible telemetry data was received for flight evaluation. The flight occurred within a month of the launch date established in November 1964 and the vehicle lifted off at 895 pounds, about 4 percent below the weight goal established early in the program. An extremely well written flight report has been published by Martin and further narrative of the flight will not be contained herein. Needless to say, it was only a few hours after the launch that analyses were underway regarding the cause of the failure. Analysis showed that the ballute was disconnected and the sequence for deployment of the main chute did begin; however, the main chute was never pulled from its container and the vehicle impacted the ocean at a high speed. Premature power shut-down on the vehicle disabled the flaps which were required for vehicle stabilization during deceleration. Again, a complete report of the causes of the failure of vehicle recovery were contained in the Martin flight report.<sup>3</sup>

Although the SV-5D was not recovered, the following significant accomplishments resulted from the successful flight of FV-1:

- PRIME demonstrated for the first time that lifting body reentry technology and techniques developed by extensive ground testing were valid in actual flight. FV-1's flight performance matched predicted performance values well.

- It was demonstrated that the systems developed for PRIME were capable of precision accuracy in guiding the SV-5D to a pre-selected point - an important result not only for research validation purposes, but also with implications for any future operational data return system as well.

- SV-5D demonstrated stable and controllable hypersonic and supersonic flight characteristics.

- Ablation effects on vehicle performance and stability during hypersonic/supersonic flight were small for this type of heat shield.

- PRIME experienced minimal blackout effects, and showed little contamination effects on its ablative thermal protection system.

- A wealth of hypersonic reentry technology data was obtained, all of high quality, including measurements of ablation rates and behavior characteristics of the thermal protection system.

The second PRIME booster was erected at Vandenberg on January 9, 1967. FV-2 progressed through the final stages of acceptance and the final ground test was run on January 16. The shroud and interstage had been delivered to Vandenberg on January 14. FV-2 was shipped from Baltimore on January 19 and was mated to the booster on January 20 in preparation for applying power. FV-3 moved into the acceptance test facility in Baltimore to begin its test and checkout.<sup>4</sup> But this was the good news. Overall, the year began with some financially unattractive requests. Overruns of contract funding were reported by Convair and Martin in December 1966. A request was made on January 9 to fund a Convair overrun of \$455,000. The major causes of this problem were increased rates, material and subcontract costs in excess of those estimated at negotiations, and the technical problems during development and testing which required greater effort than was planned. Brigadier General Paul T. Cooper (who replaced General Funk as Commander, SSD, in the fall) approved the request on January 13. He was also notified on January 18 of a potential cost overrun with Martin of about \$2.4 million. The causes were similar to those at Convair. The funding situation was a subject of the January Quarterly Review at SSD. Colonel Scoville reminded the AFSC staff that \$1.85 million had been requested previously for FY67 (\$500,000 which was diverted to PILOT in FY66 to be



returned to PRIME in FY67 and \$1.35 million because of the pad conflict). In order to relieve this requirement, the AFSC staff stated they would request the Atlas office to defer receipt of \$2.0 million in boosters to July 1967 when FY68 monies would become available. This action was taken.<sup>5</sup>

By mid-January, the ship support for the February 21 launch did not look encouraging. The first Apollo mission was scheduled for the same day and this, of course, was expected to impact on PRIME. The terrible Apollo fire disaster on January 27 resulted in a reschedule of the ship support so by the end of January support for PRIME looked good, but this would change soon enough.\* On February 7 a message was dispatched to AFSC headquarters concerning PRIME project funding for FY67 and FY68. PRIME requirements for FY67 were \$16.85 million and \$15 million was authorized. This, as mentioned above, was solved by deferring booster costs of \$2 million to FY68. The best estimate for FY68 requirements at this time was \$8.1 million to include the booster costs, incentive fees and overruns which had been recently announced. The line item for START carried only \$5 million at the time. Of the \$8.1 million required for PRIME, \$6.9 million was required in July 1967 to pay old bills. Additional funds had to be available for PRIME in FY68. Furthermore, based on the wealth of data already gained by the first flight, it was recommended to AFSC headquarters that an additional \$975,000 be added to the PRIME budget to complete two technology tasks. These were first, an analysis of spacecraft systems performance and reusability data which would be gained from a recovered SV-5D. This would involve returning a recovered SV-5D to the Martin acceptance test facility for

---

\*This was the tragic Apollo 1 (Apollo 204) mission, scheduled as a 14-day manned demonstration and checkout of the Apollo vehicle. On January 27, 1967, a pad fire at the Cape destroyed the spacecraft and killed astronauts Virgil "Gus" Grissom, Edward White, and Roger Chaffee. The first manned Apollo mission was Apollo 7, October 11-22, 1968, commanded by Walter Schirra.

detailed internal and external inspection, a complete flight simulation test and subsystem functional tests to determine performance of subsystems and possible reusability of spacecraft and typical subsystems. Secondly, Martin would undertake additional analysis to expand and improve the aerodynamic technology gained from the PRIME flights. This study would enhance the information gained from the PRIME flights and enable a better design of future lifting body spacecraft. Immediate authorization to proceed with these tasks was requested.<sup>6</sup>

During the week of February 8 the Eastern Test Range (ETR) notified SSD that the Advanced Range Instrumentation Ship (ARIS) would not be available for PRIME until February 27; so immediate action was taken to reschedule the PRIME flight. During the week of February 15 the earliest date for PRIME ARIS ship support moved to March 4. The Western Test Range (WTR) therefore rescheduled all support for PRIME to March 4 and the flight continued to be delayed due to ship support. FV-2 was proceeding through its test and checkout at the pad on schedule. A series of minor problems were had with the programer, attitude reference package, and the autopilot, and these were replaced as a safety precaution. In some cases, the new units came out of FV-3 in Baltimore and this, of course, gave the test team in the acceptance test facility their headaches.<sup>7</sup> At the end of February the second PRIME launch was still scheduled for March 4. All range support facilities such as ships and planes were moving to their stations. Reports from the terminal site indicated that they would support the Saturday launch. FV-2 was being checked out on schedule. A potential scheduling problem existed with the Maneuverable Ballistic Reentry Vehicle (MBRV) program which required the ARIS ship and the Range Tracker ship on a location about five days away from the PRIME location on March 7, 1967. Meetings were held with Ballistic Systems Division to make arrangements to allow PRIME to launch on March 4 as scheduled, before MBRV.<sup>8</sup> Nevertheless, PRIME slipped a day.

The second PRIME vehicle was successfully launched on March 5, 1967. The planned 500+ nautical mile cross-range maneuver was accomplished and thus the flight represented the first time a spacecraft performed a cross-range maneuver during reentry. (FV-2 actually executed a 654 mile cross-range maneuver). FV-2 was programmed to fly a 500+ nautical mile cross-range trajectory by maintaining a constant bank angle of 46 degrees through reentry until terminal guidance initiation. The mission profile was followed closely and all vehicle subsystems performed excellently through the launch and reentry phases. As a result, the vehicle was maneuvered within two miles of the preselected target point for recovery initiation. The recovery system sequence was successful through deployment of the main chute; however, a malfunction in the airborne system precluded attempts at aerial recovery. The backup water recovery system was deployed at impact, but the vehicle subsequently tore loose and sank before it could be recovered. (This failure and the earlier one which resulted in the lost boilerplate vehicle had nothing in common from a technical standpoint). The recovery aircraft were on station and actually saw the SV-5D as it descended on the main chute taking some excellent photographs. Recovery was not attempted because the vehicle was in a nose-down attitude rather than the nose-up attitude expected. The vehicle was in a three point suspension from the parachute rather than a single point and consequently it was later determined that cutters had failed to cut two of the lines of attachment. A complete failure analysis is contained in the Martin final report on the second flight test and will not be contained herein.<sup>9</sup> Coming on the heels of FV-1, the loss of FV-2 was a bitter pill.

FV-3 was accepted by the Air Force on March 15. Meetings were also underway that day in an effort to determine the reasons behind the failure to recover FV-2. FV-3 was delivered and erected at Vandenberg on March 17. The scheduled launch date was

April 18; however, the ship support picture again was not encouraging. Some thought was being given to reshaping the trajectories for FV-3 and FV-4 to bring them into shallower waters so that if the failure repeated itself, an attempt could be made to recover the SV-5D from the ocean bottom. On March 24, AFSC headquarters was requested to fund a \$2.784 million Martin contract overrun. Of this amount, \$2.5 million was required in 1967. Funding for the present contract effort would be exhausted by April 10, 1967. The request was signed by General Cooper.<sup>10</sup> By the end of March it was determined that the cause of the failure of the cutters to perform their task on FV-2 was that no charges (the cutters were explosive in nature) were installed. This had been a human error and action was taken to assure its prevention in the future. In early April the ship support picture looked very poor. In fact, SSD was informed that no ARIS ship support could be provided until the end of May for the PRIME flight scheduled for April 18. General Cooper talked with Major General J. S. Bleymaier (Commander of WTR) and also sent him a strongly worded letter on April 12 emphasizing the problem and requesting his support. The letter read as follows:

I was greatly surprised last week when you told me that you were unaware of our ship problems in support of the PRIME launches. My surprise stems from the fact that ship support has plagued the project from the outset and, as you know, it is so important to the success of the project.

I am sure you are aware that both of the launches have been delayed awaiting ship support. When I was informed that no ARIS could be made available until the end of May for the third launch scheduled on April 18, we carefully reviewed our ARIS requirements in the light of the very successful demonstration on the first launch that the theoretical trajectory could be met and that the guidance system was capable of maintaining the course of the vehicle. The ARIS data, incidentally, was of good quality and very useful in enabling an accurate reconstruction of the flight trajectory. Unfortunately, the tracking data from the Range Tracker was of short duration on the first flight and totally lacking on the second.

In view of the significant costs which would be incurred in waiting for the ARIS ship, we have decided to forego the ARIS requirement and to proceed with the flight on schedule with only the Range Tracker as a Category I requirement. Because of our dependence on the Range Tracker, I have been seeking assurances from Colonels Rochte and Scoville that the poor results on the two previous launches will not be repeated on the third launch. I have tried to insure that the START Program Office and the 6595th review every aspect of the ship problem with the appropriate WTR personnel. I call to your attention the attached April 5 memorandum from Colonel Rochte on this subject and its enclosures. Note that the meeting of January 26 attended by five WTR/FEC personnel discussed the poor quality of the Range Tracker data and the ship positioning problem. WTR agreed to take action in this regard. Similarly, after the second launch, the launch critique on March 8, attended by only three WTR personnel, discussed the complete lack of Range Tracker data and again WTR was asked for an explanation. This was followed up on March 20 by a letter to WTR from Colonel Worthington. The WTR response on April 3 did not answer the fundamental question as to the ability of the Range Tracker to determine its own position or whether new procedures are necessary in order to prevent a recurrence of the failures experienced on the second launch.

I understand that a meeting was held at WTR on April 7 between Colonels Worthington, Vinzant, and Scoville to further consider solutions to the past problems with the Range Tracker. This meeting will result in placing appropriate priority on improving our communications between the ships and our control centers at Vandenberg. Also, it should result in the establishment of criteria to better define the conditions under which the ships can be expected to provide satisfactory data. These two actions should significantly contribute to greater confidence in satisfactory results from the Range Tracker.

In view of our decision to forego the ARIS data requirements and to rely upon the Range Tracker, I believe you will agree that the Range Tracker problem warrants your personal attention. I do not intend to authorize the third launch next week unless AFWTR can give some assurances as to the adequacy of the Range Tracker.

On April 12 a message to AFSC headquarters was also signed out by General Cooper requesting immediate action be taken to release

funds for the Martin contract since all government funds had been expended and the Martin Company had already used about \$700,000 of its own money. A request was made for an immediate \$1.9 million and for \$.9 million in early July 1967.<sup>11</sup>

On April 17 and 18 the Range Tracker was encountering high seas and several alternate positions were suggested for accomplishing the launch. On April 18 a problem with the booster threatened to delay the launch at least 24 hours. On April 19, the third PRIME flight was launched in a trajectory simulating reentry from a low-earth orbit with a maximum cross-range maneuver. Performance of the SV-5D and all its subsystems was completely successful through all phases of launch, reentry and recovery. As a result, even though the ground based terminal guidance was unoperative, the vehicle was maneuvered more than 710 miles cross-range to a point less than 5 nautical miles from the preselected target for recovery initiation. A waiting Lockheed JC-130B successfully snagged the SV-5 at 12,000 feet, and the vehicle was returned to Martin-Baltimore for inspection, study and post-flight testing. With this flight, all PRIME project objectives were clearly accomplished.<sup>12</sup> Figure 19 shows this maximum reentry cross-range ground track.

Work pressed on to launch FV-4. FV-4 finished its test and checkout at Martin-Baltimore and was on schedule for shipment to Vandenberg on April 28. The shroud and interstage were shipped on April 25 and the booster was erected on April 28. Trouble shooting began immediately into the failure of the terminal area ground guidance to acquire and guide the SV-5D, to prevent a repetition on FV-4. But then review of FV-3's great success resulted in a growing climate of opinion against launching FV-4. On April 28 FV-3, the recovered SV-5D, successfully passed a combined systems acceptance test (flight simulation) in the ATF at Martin-Baltimore. No problems were encountered in the test and it would have therefore been accepted by the Air Force had it been

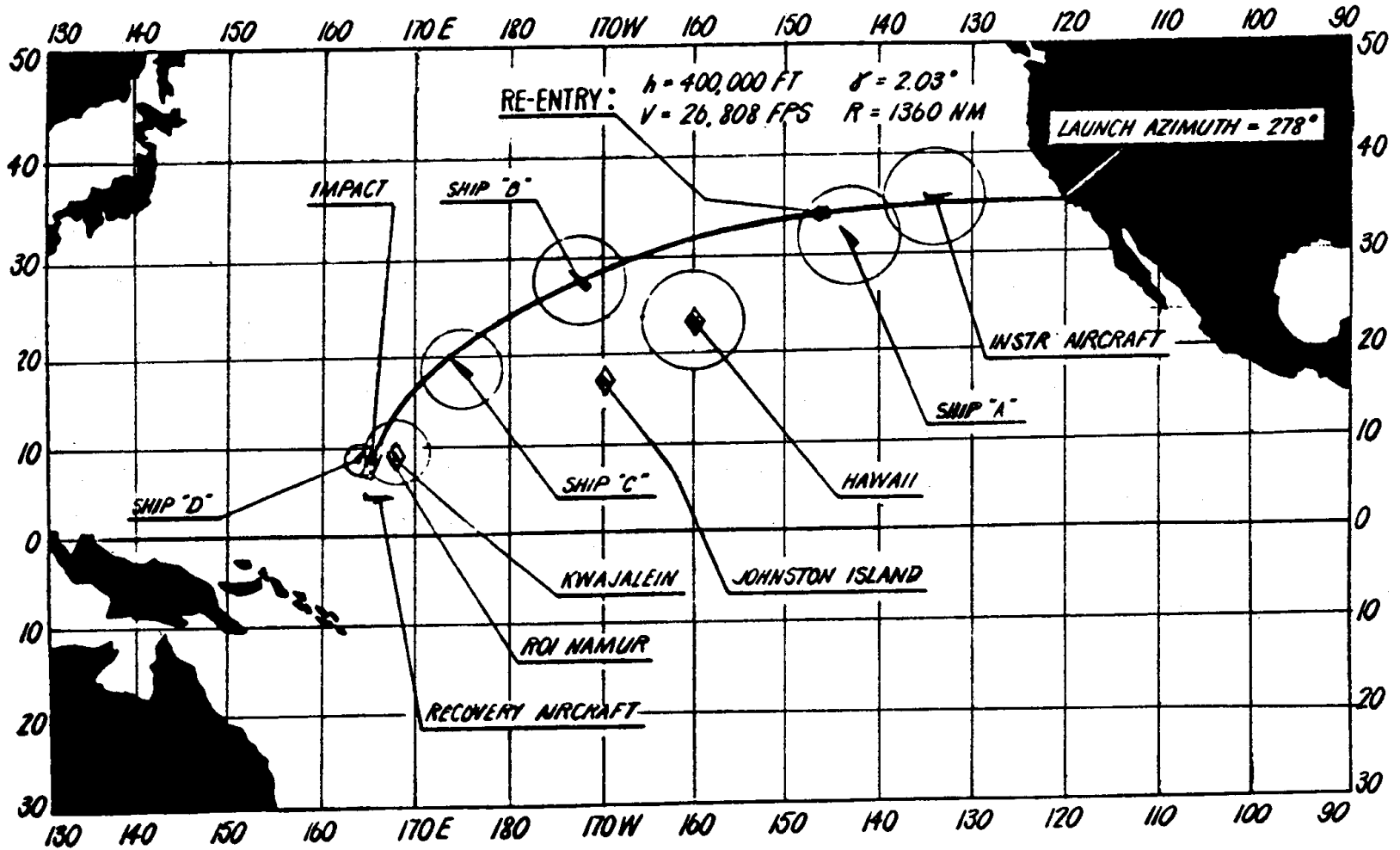


Figure 19

FV-5. Certainly this was an initial milestone in demonstrating the reusability of lifting spacecraft. Analysis was being conducted and tentative plans were being made to increase the cross-range maneuver on FV-4 to about 800 to 850 nautical miles. In early May some indications were received from Washington that there was a good possibility that FV-4 flight would be canceled. Generals Cooper and D. V. Miller, SSD Vice Commander, were briefed on May 3 and 5 respectively on the proposed flight plan for FV-4. They did not make an immediate decision on FV-4, a further indication that something was in the wind. On May 9 Colonel L. S. Rochte (Deputy for Technology) signed a memorandum to General Cooper strongly recommending that FV-4 be launched as scheduled. The memorandum presented a good summary of reasons for another SV-5D flight. The memorandum read as follows:

1. In accordance with your instructions, an analysis has been conducted to:

- a. Identify the estimated dollar savings which would result from the immediate cancellation of the flight test of PRIME FV-4.

- b. Identify and describe the new information and data to be required by a flight test of PRIME FV-4.

- c. Evaluate the relative value of the new data to be acquired by performing the flight test of PRIME FV-4 in comparison with the estimated dollar savings to be realized from an immediate cancellation of the fourth flight.

2. The dollar savings resulting from an immediate cancellation consist of:

- a. The Martin-Baltimore PRIME vehicle contract, which it is estimated would yield \$490,000.



b. The GD/C SLV-3 launch services contract, which it is estimated would yield \$282,000.

c. Additional savings in the launch area (Lockheed Ground Station manning, propellants and GD/C interstage postflight analysis), would yield an estimated \$170,000.

d. The GD/C SLV-3 hardware contract, which it is estimated would yield \$1,200,000 for the START line if ARSP or ABRES were the user for a ballistic flight, or \$600,000 would be recouped for the START line if an orbital flight program were the user.

3. The cost differences in recoupments cited immediately above can be explained by the booster subsystem changes according to the following breakout:

	<u>Ballistic Flight (\$K)</u>	<u>Orbital Flight (\$K)</u>
GD/C Airframe	\$ 735	\$ 515
Rocketdyne Engines	600	600
GE Mark II Guidance	125	125
Burroughs Flight Analysis	70	--
Accoustica Stillwells	30	30
Instrumentation	<u>10</u>	<u>--</u>
	\$1,570	\$1,270
Less Autopilot reprograming potential recycling, ECPS (Tank)	<u>-370</u>	<u>-670</u>
BOOSTER NET SAVINGS	\$1,200	\$ 600

4. The estimated maximum dollar savings accruing to the START line are summarized as follows:

a. From Martin-Baltimore contract	\$ 490,000
b. From GD/C SLV-3 launch contract	282,000
c. From miscellaneous launch services	170,000
d. From GD/C SLV-3 hardware contract (assuming orbital program user for FV-4 booster)	<u>600,000</u>
Estimated subtotal recouped	\$1,542,000

5. Adding the estimated maximum direct costs for range and terminal area support, the total possible savings to the government are summarized as follows:

a. Estimated total recouped from Martin, GD/C and miscellaneous launch services (START line item) \$1,542,000

b. Estimated maximum range/terminal area  
direct costs 331,650  
Government savings - estimated grand total \$1,873,650.

6. It should be noted that the cost figures presented are estimated only, and have not had the benefit of audit. It is therefore possible that the estimated cost savings shown above will be reduced as a result of audit. It is also pointed out that necessity would dictate an early decision as to the cancellation of a fourth flight and this estimate presented here is based on issuance of stop-work effective May 10. A decision at a later date would obviously cut into the dollar savings on a day-to-day basis. Experience has shown in partial termination, which this would be, that initial estimates are unrealistic and generally actual termination will cost more.

Because this partial termination is a convenience to the government, we could expect full charge application against the current Martin contract.

7. The new information and data which could be acquired by the flight test of PRIME FV-4 are summarized as follows:

a. Extension of the envelope of aerodynamic data. This would include:

(1) A determination of stability derivatives of the SV-5D by perturbing the vehicle attitude during the flight. These data are not presently available from the three PRIME vehicle flights on the SV-5D configuration and a knowledge of the effects of perturbation is necessary for future applications. It is now possible to accomplish this because the contractor now has an understanding of the vehicle's behavior when subjected to perturbing influences.

(2) Obtain from flight test new aerodynamic and thermodynamic data by flying at a lower angle-of-attack ( $30^\circ$  instead of  $35^\circ$ ) and a higher bank angle ( $47^\circ$  instead of  $39^\circ$ ) than previously flown.

(3) Obtain aerodynamic data in a lower velocity regime by flying the vehicle to a lower Mach number at ballute deployment. This would also provide an overlap of data with that acquired from the PILOT project for correlation purposes. At present, there is 0.4 Mach number gap in velocity envelopes of PILOT and PRIME. That is, PILOT will fly Mach 2.0 and lower velocities down to horizontal landing. The PRIME vehicle terminated flight at Mach 2.4, the FV-4 at Mach 1.8.

(4) Verify new predictions, based on data from three previous flights, for vehicle performance and accuracy. Improved maneuver accuracy is expected at the point of terminal guidance initiate. We believe it now possible to obtain an accuracy of 10 n.m. before terminal guidance corrections are initiated in comparison with approximately 30 n.m. for previous flights.

(5) Verify a new pitch attitude correction profile established for FV-4 from resolution of the pitch guidance correction anomaly occurring on previous flights.

b. Extend the reentry heating environment. (Stagnation heating  $Q_t = 7,000 \text{ BTU/ft}^2$ ). The increased cross-range maneuver for FV-4 will subject the vehicle to more severe reentry heating and therefore provide aerothermodynamic data on a new set of reentry environmental conditions.

c. Extend knowledge of communication through the plasma sheath. Last year, SST introduced this as an area of critical technology to RTD and Gen. Demler directed the Avionics Laboratory to establish a formal program of major proportions to investigate techniques and proposed developments. By positioning ships and aircraft for maximum coverage on exit from blackout, FV-4 can extend the data obtained from previous flights.

d. Demonstrate improved terminal guidance on a maximum cross-range flight. TRADEX was unable to establish a satisfactory track profile on FV-2 flight until shortly before ballute deploy, and did not acquire the vehicle on

FV-3 flight. Adequate terminal guidance is of significance for future full scale maneuverable spacecraft operations. It is therefore necessary to determine if the anomalies encountered are due to hardware, software, or some unknown properties of charred heat shield. FV-4 flight would afford the opportunity to resolve this problem and verify improved performance of the ground based terminal guidance system.

e. Recover vehicle for additional postflight analysis. A wealth of data additional to telemetered information can be obtained by physical inspection and test especially on heat shield performance. Another recovered vehicle increases the scope of postflight analysis. It is understood that one vehicle would be sent to the Smithsonian Institution, leaving the second vehicle for additional analysis and experimentation. An additional data point will be provided by FV-4 in its different and more stringent reentry environment. Also, the recovered vehicle may be retested to ultimate values without fear of destroying the only test specimen.

f. Obtain additional IR and optical signature data. Some limited IR data were obtained from Program 461 coverage on FV-1. It is planned to extend this through IR and optical tracking of FV-4 in the region of high heating (first dip) using TRAP (Terminal Radiation Program) aircraft.

g. Demonstrate additional cross-range performance (approximately 790 n.m.). This would increase confidence in the maximum cross-range capability of a full scale configuration in the medium L/D class and by verifying

the improved estimate of PRIME vehicle aerodynamics, provide a better extrapolation of the predicted performance for a full scale vehicle.

h. Refly FV-3 components. FV-3 has completed a successful combined systems test and a study is being conducted to investigate selected components for reflight in FV-4. This would be a demonstration of reuse if the study conclusions are favorable.

i. Obtain ground tracking of the vehicle in the terminal area to assist reconstruction of maximum cross-range trajectory. This was not obtained during FV-3 flight because of failure of TRADEX to acquire the vehicle. Good trajectory data are required to reconstruct the maximum cross-range flight which would be achieved with FV-4.

8. Approximately \$70 million has been invested in the PRIME project not including M-103 and PILOT. Cancellation of the FV-4 flight would reflect only a 2 percent reduction of the investment. This percentage is lower if the total START investment (M-103 contract and PILOT) is included. It is not possible to assign a dollar value to the new data that would be acquired by flying FV-4. It can be argued that a decision to cancel FV-4 flight is irreversible. The PRIME flights, including FV-4, provide the only lifting body reentry data existing in this country. In our judgment, the relatively small savings that would be realized by cancellation are more than offset by the technology gains resulting from the flight of FV-4.

9. The booster cost information has been coordinated with Col. Hamilton and Col. Sullivan.

10. In view of the foregoing considerations, I strongly recommend that the PRIME FV-4 vehicle be flown as scheduled.

The effort was futile, however, because on May 12, the following USAF message was received by AFSC headquarters:<sup>13</sup>

Information available to this headquarters indicates that all planned major test objectives were completed with the very successful third flight on April 19, 1967. We also understand that a reoriented fourth flight to obtain additional data, not originally under contract, would add costs to the approved program. USAF is faced with an extremely tight funding situation for FY67 and FY68. Approved FY68 FYDP START funding is inadequate to pay obligations already incurred. Unless there are overriding technological reasons to the contrary, and firm cost commitments are available which affirm no increase in program costs, AFSC is directed to take the following actions: (a) cancel the fourth flight, and (b) inform this headquarters of estimated savings to be realized, how savings will be applied to the START program, and revised FY68 funding requirements. Request response by May 16, 1967.

PRIME was over, and AFSC knew it. The following message was sent in reply to this request on May 15:<sup>14</sup>

Action was taken on May 12, 1967 to terminate all contractual and support effort associated with PRIME fourth flight.

Savings resulting from this cancellation are estimated at \$0.94 excluding booster hardware. Assuming that a Space program is the new user, approximately \$0.60 million additional could be recouped for booster hardware at a date as yet undetermined.

We plan to apply above savings to following efforts:

a. \$0.18 million for aero/thermo analysis to determine the ablation process and real gas effects on flow field of a reentry ablatively protected lifting body spacecraft. The results will give a more accurate prediction of the aerothermodynamic parameters of this class vehicle.

b. \$0.57 million for spacecraft reuse study and testing to produce a practical evaluation of the feasibility of a reusable reentry vehicle based on the inspection, rework and retest of the recovered PRIME lifting body reentry vehicle.

c. \$0.19 million for communications blackout analysis to yield a proven theory of blackout prediction on which to base the design of future ablatively protected lifting body reentry vehicles. The aim is not necessarily to eliminate blackout but rather to enable a better prediction of effects of this phenomenon on this class spacecraft. The purpose of these tasks is more fully described in the Martin Co. Unsolicited Proposal forwarded to your headquarters by letter dated March 13, 1967, subject: "Recommendations Regarding Unsolicited Proposal." Immediate authority to pursue these tasks is requested.

PRIME project close out costs are now projected at \$5.16 million. Tasks outlined in Part III above are estimated to total \$0.94 million. Total FY68 PRIME project requirements plus added tasks are projected at \$6.10 million. Assuming that the \$1.90 million borrowed from Program 949 to partially fund FY67 deficit in the PRIME project must be returned to 949 in FY68, total START program dollar requirements in FY68 total \$8.0 million, exclusive of the PILOT project. (Reference Minutes of Hq USAF/Hq AFSC Space Systems/Programs Quarterly Review, April 3-4, 1967).

On May 18 the additional technology tasks described in the above message were approved by Headquarters AFSC. Later, the funding was reduced to \$500,000 for this effort and the communications blackout analysis was to be done without increase in program cost by the Aerospace Corporation's Plasma Research Laboratory. The reuse analysis was contracted at \$320,000 and the aerodynamic analysis at \$180,000 as a contract change to the existing contract.<sup>15</sup>

On May 3, Dr. John Foster, DDR&E, signed out a memorandum to Dr. Flax, subject, "Success of START Program's PRIME Flight Tests" which read as follows:



I wish to congratulate you on the outstanding flight tests of the PRIME maneuvering entry spacecraft. The remarkable record to date -- three successful maneuvering entry flights out of three launches, and the recovery of the last spacecraft after maneuvering hundreds of miles from the ballistic plane, an unprecedented achievement in space technology -- is a tribute to the technical competence of the Air Force and industry members of the START program.

With pride I take special note of the Air Force management of this program. It sets an admirable standard for follow-on spacecraft technology programs.

Please extend my thanks and commendations to those personally involved in this program for their outstanding achievement in advanced development and program management.

On May 23, Colonel Scoville participated in a press conference held in the Pentagon on the PRIME project. Although public release of information on START program had been a delicate item. Colonel Scoville coordinated and then issued the following statement:

Today I would like to talk to you about the Air Force's lifting body technology program. Specifically, I would like to describe the results of a maneuverable reentry spacecraft development and flight test program. This is called the PRIME project. PRIME is an acronym for Precision Recovery Including Maneuvering Entry.

The project was approved in November of 1964 with a schedule to complete first flight in 24 months. We are on schedule and last month we successfully completed our third flight within 1-day of the original schedule established at program inception. With the successful third flight, we have achieved most of the primary objectives of the project. The recovered vehicle from the third flight is available for your examination.

Before I proceed into a general description of the project, I would like to define for you what is meant by the term lifting body. This is a wingless vehicle, with its body shaped like an airfoil. It, therefore, develops

aerodynamic lift while passing through the atmosphere just like our conventional airplanes. It must survive the rigors of reentry from orbital velocity. This tells you that with lifting bodies, we are essentially marrying the technologies of the ballistic reentry vehicles with that of aircraft. The PRIME project represents the first flight test of the successful marriage of these technologies, and this essential point describes for you the significance of this accomplishment.

The program was planned to meet five specific flight objectives:

1. Acquire heat shield and aerodynamic data.
2. Demonstrate accurate guidance of the vehicle to the recovery point.
3. Demonstrate cross-range maneuvering.
4. Recover a vehicle, and
5. Demonstrate a design for performance with minimum weight.

The 860-pound PRIME vehicles, designated SV-5D, were launched from Vandenberg Air Force Base on Atlas SLV-3 boosters. The flight profile is designed to simulate, as closely as possible, the trajectory of a spacecraft reentering from orbit. Like other spacecraft, a reaction control system--in this case nitrogen gas thrusters--orients the spacecraft to the proper attitude for reentry. Both the reaction system and the flaps are used for attitude control during the initial phase of reentry until the reaction control system is no longer needed. For the remainder of the flight - within the atmosphere - all maneuvering is accomplished by the hydraulically-actuated flaps. Guidance for most of the missions including the maneuvers is performed by an inertial system onboard the vehicle. A ground-based, terminal guidance is used to direct the vehicle to the recovery point.

Evaluation of data from the three flights indicates that the vehicles were aerodynamically stable and responded well to flap commands. Performance of the wrap-around heat shield, a newly developed material used in a different form on this vehicle, was excellent. It kept temperatures of the aluminum skin (or substructure) lower than expected despite surface temperatures of 3,000 degrees Fahrenheit. The airborne guidance system guided all three vehicles to the terminal area within the required accuracy.

These flights also demonstrated that ablation of the heat shield had no degrading effects on stability and control because the aerodynamic shape of the lifting body vehicle was maintained.

Post-flight tests run on this recovered vehicle indicate all systems are in operating condition and are capable of flying again. This fact provides support for the reusability of such spacecraft.

The technological data obtained from the PRIME flight will be particularly valuable in the areas of aerodynamics and materials. The information received on subsystem performance will be of considerable value to future maneuverable reentry spacecraft.

PRIME is appropriately named since it was the first vehicle to make a truly maneuverable reentry from space.

Looking towards the future, the Air Force is conducting studies to define and optimize configuration and subsystem characteristics of a multi-purpose reusable spacecraft. Meanwhile, both the NASA lifting body program and the Air Force's START program are contributing to any future development by establishing a technology base from which such a system could evolve with minimum risk and cost.

It was as good an epitaph for a remarkably successful program as could have been written. After PRIME ended, General John McConnell, the Chief of Staff, asked Scoville, in effect, "What do we do next?" The Air Force subsequently decided that an operational data-return SV-5D would be too expensive, the mission could be fulfilled more efficiently by other means, and that while the SV-5D had been a superb example of technology demonstration, the service could not justify expanding the SV-5 for an operational role on its own.<sup>16</sup>

So the highly successful PRIME project came to an end. When word of the cancellation of the fourth launch was received, the program office began an immediate phaseout. By mid-July 1967, the majority of the office personnel had been transferred to new jobs within SAMSO (Space and Missile Systems Organizations), working

the space frontier.\* Colonel Scoville transferred to USAF headquarters at the Pentagon as Chief of the Missile Systems Division under the Deputy Chief of Staff for Research and Development. The final close-out task of the START program was turned over to Major W. Glushko as head of the Space Vehicle Re-entry Branch. This branch was a part of the Directorate of Engineering and Technology. Among the tasks to be accomplished by this branch were: (1) management of the three PRIME follow-on tasks being performed by Martin and the Aerospace Corporation, (2) disposition of all GFE assigned to the Martin and GD/C contracts, (3) publication of final reports, (4) publication of all technical papers and reports written on PRIME by men that worked on the project, and (5) planning the next step to be made by the Air Force in lifting reentry technology. The final report on the spacecraft reusability analysis would be published in October 1967 and the results of the aerodynamic analysis would be available in December 1967.

In summarizing the results of the PRIME project, the following impressive matching of objectives with accomplishments stands out:17

<u>Objective</u>	<u>Accomplishment</u>		
	<u>Flight 1</u>	<u>Flight 2</u>	<u>Flight 3</u>
Demonstrate reentry performance at cross-range up to at least 700 naut mi	✓	✓	✓
ACTUAL CROSS-RANGE, NAUT MI:	0	499	>710

---

\*SSD and BSD had been combined to form SAMSO under Lt. Gen. J. W. O'Neill.

	<u>Flight 1</u>	<u>Flight 2</u>	<u>Flight 3</u>
Demonstrate 10-naut mi maneuvering accuracy	✓	✓	✓*
ACTUAL DISPERSION, NAUT MI:	0.15	1.91	4.27*
Demonstrate vehicle stability and control	✓	✓	✓
Verify SV-5D subsystems design	✓	✓	✓
Recover vehicle after reentry	No	No	✓
Provide reentry technology data	✓	✓	✓
PERCENT TELEMETRY			
OBTAINED:	91.2%	99.3%	99.5%

\*Terminal guidance radar inoperative

In addition to the fulfillment of these specific objectives, the PRIME test flights constituted the first full-scale flight demonstrations of an aerodynamically maneuverable lifting body reentry vehicle in the hypersonic and supersonic velocity regimes. The high degree of success achieved attests to the validity of the various analytical methods and laboratory test techniques used in the design. All the vehicles were better than 3 percent below the specification maximum launch weight established early in the design phase. The third and final launch was accomplished precisely on the schedule date, established more than two years previously at the inception of the PRIME project. Finally, these three flights satisfied all PRIME project objectives to such a degree that the originally planned and imminent flight of a fourth vehicle was adjudged to be unnecessary and was therefore canceled.

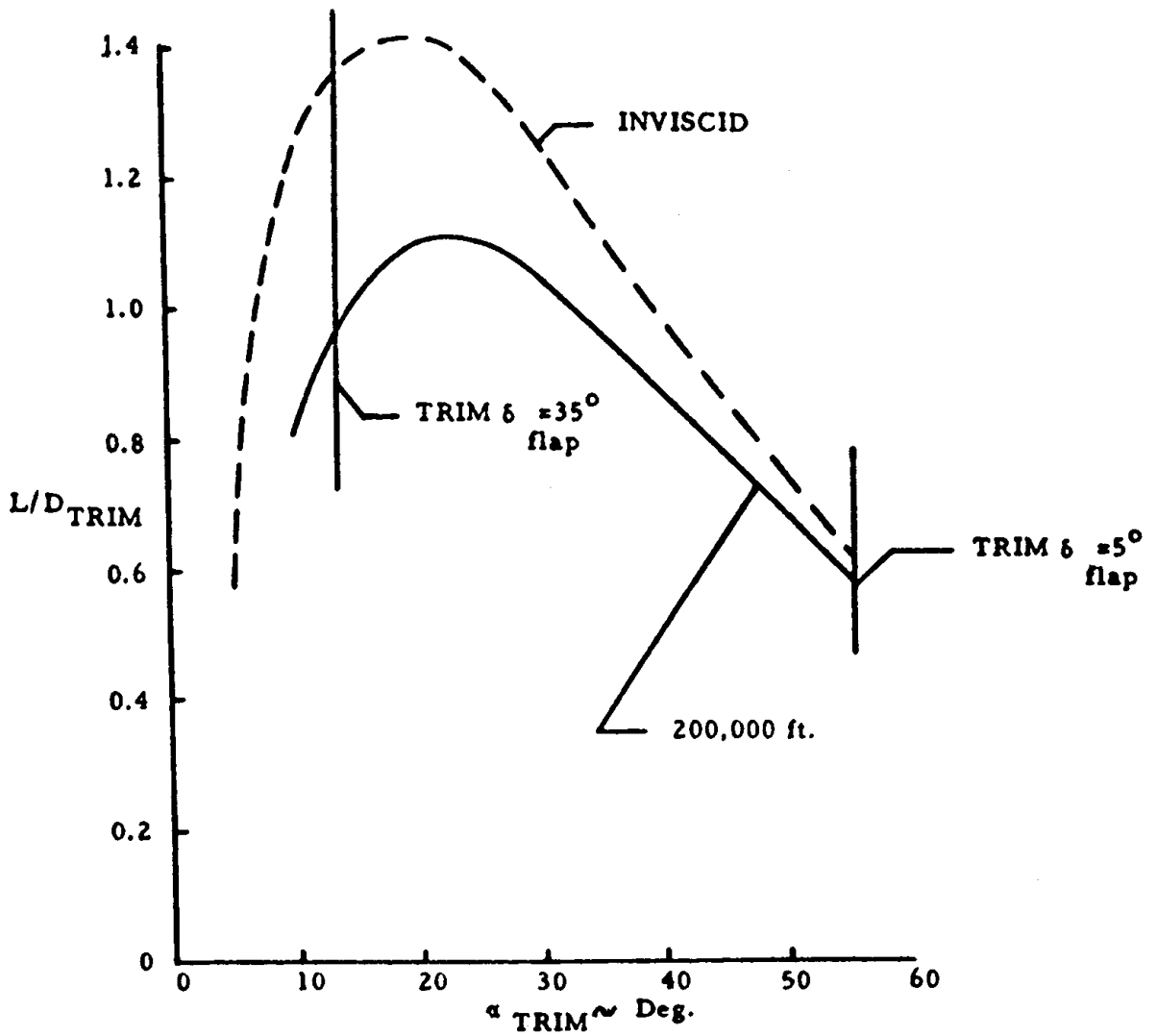
An extremely important by-product of the PRIME program was the generation of actual flight test experience and data in the many

and diverse disciplines involved in lifting body maneuvering reentry. Recommendations for further technology investigations of the generated data were made, and some were subsequently implemented in follow-on studies. Some specific contributions of the PRIME flight test program to reentry technology are summarized as follows:

Trajectory reconstruction. An indispensable tool for flight analysis was developed by Martin, in the form of the Statistical Trajectory Estimation Programs, STEP 1 and STEP 2, which fit the equations of motion to the tracking data in a minimum variance sense. In the Flight 1 analysis, the STEP 2 reconstruction was instrumental in revealing a very significant but unsuspected bias error in the booster guidance radar. The Flight 2 reconstruction incorporated refinements in technique and was very satisfactory. In the case of Flight 3, however, a fully satisfactory reconstruction could not be achieved in the time available, due to an almost complete lack of reliable tracking data after reentry. Time and the scope of the current program did not permit much experimentation with STEP 1, the more sophisticated version, which is designed to yield more diverse and detailed information than STEP 2. It is recommended that further work with STEP 1 and the existing PRIME flight data would be of significant worth to reentry technology.

Aerodynamics. Figures 20 and 21 show plots of various measured quantities analyzed during reentry. The aerodynamic data derived from PRIME flights have in general confirmed the validity of SV-5D aerodynamic design procedures and wind tunnel test techniques, except for some persistent discrepancies in the flight regime where ablation effects are at a maximum. Empirical methods have been postulated that correct for these ablation effects with reasonable success, but a thorough understanding of the physical

Figure 20



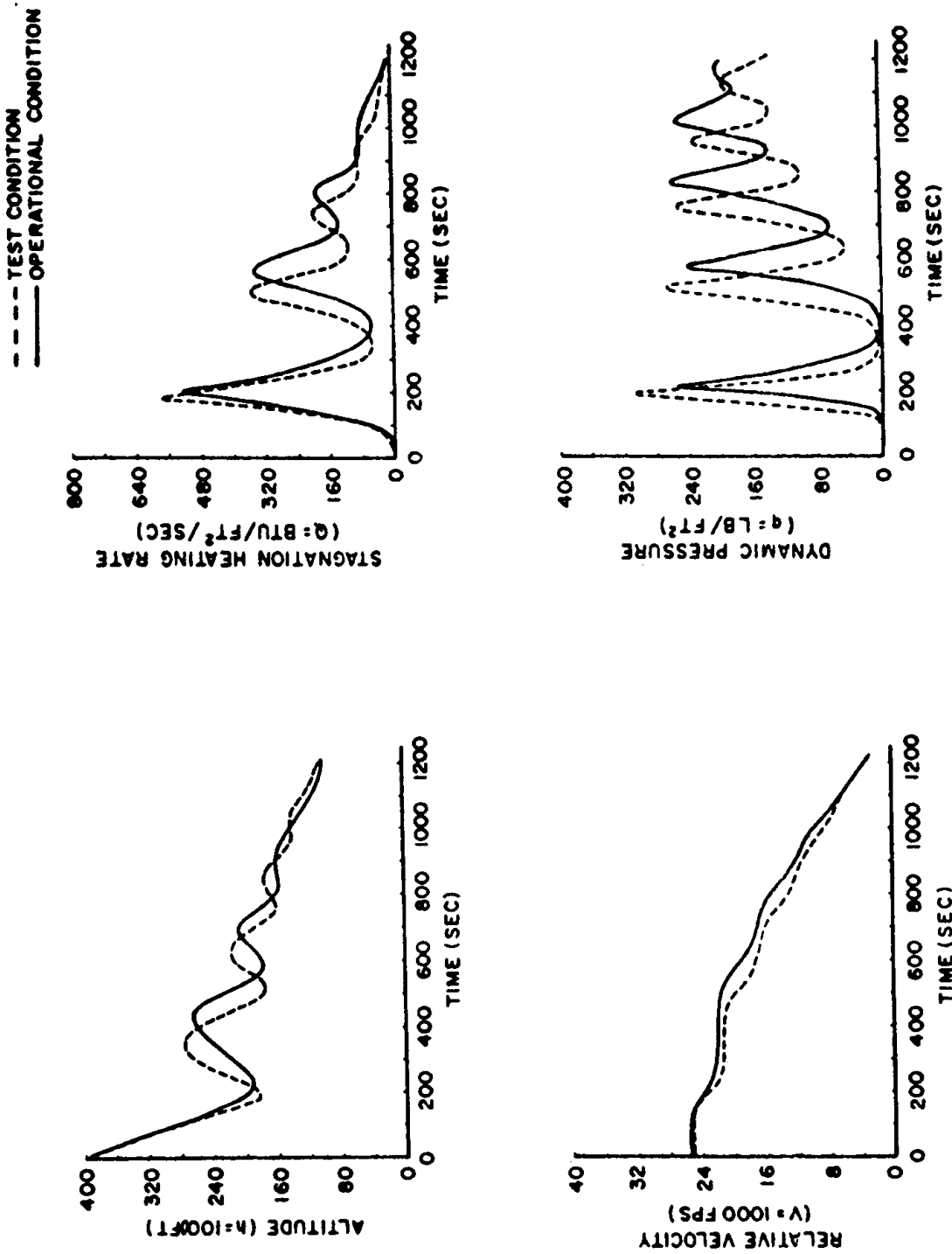
SV-5D HYPERSONIC LIFT-TO-DRAG RATIO

(L/D VS. TRIM ANGLE OF ATTACK)





Figure 21



COMPARISON OF RE-ENTRY PARAMETERS FOR A TEST SV-5D  
 VS. OPERATIONAL SV-5D USING A BASELINE  
 A 700 n.m. CROSS-RANGE RE-ENTRY

phenomena involved has not yet been attained. Further investigation of this area constitutes a major part of the follow-on studies mentioned above. PRIME meteorological data confirm that the COESA 1962 standard atmosphere would provide a much better representation of the conditions actually encountered on the Western Test Range than did the ARDC 1959 atmosphere.

Heat shield and structure. The PRIME flights demonstrated the feasibility of using lightweight ablative material to protect lifting body reentry vehicles without degradation of their aerodynamic contours or loss of char after cooling. It is noted that the heat flux conditions encountered by the small PRIME test vehicles were considerably more extreme than those to be expected for larger operational vehicles. The heat shield material characteristics and design procedures (i.e., math model and plasma arc testing) were confirmed, both by the flight results and by examination and measurement of the recovered vehicle. It has been demonstrated that heating rate distributions derived from the wind tunnel are sufficiently accurate for conservative design; in fact, the SV-5D heat shield could be redesigned today to withstand the same environment with substantial reductions in material thickness and weight. The use of aluminum structure serves to provide an excellent heat sink, reducing temperature gradients and consequent thermal stresses to very low values. Finally, the practicality and reliability of the unique heating instrumentation developed for this program were particularly noteworthy.

Mass properties variations during flight. By physically weighing the recovered FV-3, it was possible to establish that the actual in-flight weight losses due to ablation were less than originally anticipated. This is presumably due to redeposition of a larger proportion of ablative vapors as they were passing through the char layer. Empirical factors were established to properly correct future calculations for this effect.

Guidance and control. All three PRIME flights demonstrated highly successful operation of the first pulse-rebalance strapped-down airborne guidance system, and its associated reaction jet and aerodynamic flap control systems. Relatively simple guidance laws were mechanized and demonstrated a high degree of airborne and terminal guidance accuracy, even in the presence of unexpected and severe perturbations. The guidance hardware also included provisions for counting the gyro and accelerometer pulses and digitizing the counts to provide accurate telemetry data for trajectory reconstruction. The single pair of aerodynamic flaps successfully provided pitch and roll control, with adequate aileron motion of the flaps even in the presence of large elevator deflections.

Flap actuation. Effective operation of the unitized hydraulic system, with built-in instrumentation, constitutes a significant step improvement in overall efficiency for advanced systems. High temperature flap hinge and crank spherical self-aligning bearings, designed specifically for the PRIME reentry environment, were entirely successful.

Recovery. Flight 3 marked the first fully successful operational usage of the PRIME aerial recovery system, which represents a significant advance of the recovery art in many respects. The unprecedented use of the ballute as a drogue device in a high dynamic pressure and supersonic Mach number environment was successful in all three flights. The canopy-cone type main parachute, specifically designed for aerial retrieval and applied for the first such usage on this program, constitutes a major achievement in terms of lightweight, high packing density, stability, and facility of retrieval operations. The aircraft energy absorber, developed to reduce retrieval impact loads on both vehicle and parachute, has innumerable potential applications for future recovery systems.

Environmental control. Successful flight operation of the PRIME evaporative cold plate system has demonstrated an advance in

the state-of-the-art for reliable, compact, lightweight, expendable cooling systems.

Telemetry, tracking and command. Attenuation (blackout) of C-band and VHF transmissions from the fin-mounted antennas proved considerably less severe than anticipated, although VHF in particular appeared quite sensitive to vehicle dynamics. A better understanding of this phenomenon will require more comprehensive mathematical analysis and materials testing -- such a program has been recommended to the Air Force. The unique "tuned notch" and cavity-backed slot antennas built into the fins were optimum for space and size, and still their performance was more than adequate and was not degraded by the reentry environment. The perfectly successful operation of the command system constituted the first known demonstration of continuous digital data transfer at UHF using parallel bit word structure.

Instrumentation. PRIME telemetry data, as recorded by the CARLOS ground station at Ennylabegan, were of excellent quality. By virtue of the playback from the airborne magnetic tape recorder in addition to the real-time transmittal, this one station was able to provide complete reentry telemetry records for each of the flights. The airborne instrumentation itself proved extremely reliable, as evidenced by retrieval of more than 99 percent of the data on the last two flights (loss of about 8 percent of the data on the first flight was attributed to premature shutdown of telemetry by a guidance programer malfunction).

Electrical. The flight data provided electric power requirements information which will prove valuable for optimal sizing of future flight batteries, as well as indications that in-flight battery depletion may have been less than that predicted from ground tests. The use of a heat-flowing plastic layer to seal connector faces for the prevention of electrical shorts was successfully demonstrated for the first time in a long-duration reentry.

In all of these ways the little SV-5D had advanced the data base of hypersonic flight. Much remained to be done, of course, before the capability existed to develop a manned lifting reentry system that could function as today's shuttle orbiter does. Yet the SV-5D had helped point the way. For a while, during the mid-to-late 1960s, drawings abounded in the popular aerospace press of advanced manned SV-5 ferrycraft docking with the ill-fated MOL or undergoing the rigors of reentry. While such events did not come to pass, the climate of thought that encouraged such healthful fantasies remained active and indeed grew stronger, as the effort on the piloted lifting bodies from 1967 through 1975 clearly demonstrates. PRIME, then, was of PRIME importance, and constituted a fitting companion work and successor to ASSET.

## NOTES

1. Minutes of September PRIME Management Review, September 1966.
2. Formal submittal of information for General Cooper's weekly staff meeting, submitted by Colonel C. L. Scoville, 5 December 1966.
3. PRIME Test Flight No. 1, Flight Analysis, Martin Report, ER 14461, March 1967.
4. Formal submittal of information for General Cooper's weekly staff meeting, submitted by Colonel C. L. Scoville, 1 January 1967.
5. Ltr, Colonel L. S. Rochte, Deputy for Technology, SSD to SSG, 9 January 1967, subj: Request for Authorization to Fund Overrun - \$455,864; Contract AF 04(695)-729. Ltr, Colonel L. S. Rochte, Deputy for Technology, SSD to General P. T. Cooper, Commander, SSD, 18 January 1967, subj: Potential Cost Overrun on PRIME Project, Martin Company Contract -643.
6. Msg, SSTS-23166, SSD to AFSC, 7 February 1967.
7. Formal submittal of information for General Cooper's weekly staff meeting, submitted by Colonel C. L. Scoville, 13 February 1967.
8. Formal submittal of information for General Cooper's weekly staff meeting, submitted by Colonel C. L. Scoville, 27 February 1967.
9. PRIME Flight Test No. 2, Flight Analysis, Martin Report, ER 14462, June 1967. See also Joel W. Powell and Ed Hengeveld, "ASSET and PRIME: Gliding Re-Entry Test Vehicles," Journal of the British Interplanetary Society, XXXVI (1983), pp. 369-376.
10. Ltr, General P. T. Cooper, Commander, SSD, to AFSC (SCC), 24 March 1967, subj: Request for Authorization to Fund Overrun, Contract AF 04(695)-643, \$2,784,012.
11. Msg, SSGE-00029, SSD to AFSC, 12 April 1967.
12. PRIME Test Flight No. 3, Flight Analysis, Martin Report, ER 14463, July 1967; Powell and Hengeveld, pp. 374-376.
13. Msg, AFRDS-85427, USAF to AFSC, 12 May 1967.
14. Msg, SSG-00043, SSD to AFSC, 15 May 1967.

15. Msg, MSFU-13839, AFSC to SSD, 18 May 1967.

16. From a telephone conversation with Colonel C. L. Scoville, USAF (retired), by R. P. Hallion, 1979.

17. PRIME Final Flight Test Summary, Martin Report, ER 14465, September 1967.

APPENDIX A  
PRIME PROJECT COST

Like ASSET, PRIME was a basically "cheap" R&D investment that offered technological payoffs far in excess of the capital invested in its development and testing. The costs incurred by the PRIME project were as follows: \*

I PRIME COSTS BY CONTRACTOR

A. Martin Contract AF 04(695)-643 (SV-5 development):

Basic Contract	\$36,624,816.
Fee	<u>2,929,982.</u>
	\$39,554,798.
CCNs plus Fee	<u>3,684,052.</u>
	\$43,238,850.
Spares and Fee	1,400,000.
Overrun	2,784,012.
Performance Incentives	<u>754,650.</u>
	\$48,177,512.
Less Anticipated Recoupments	
Overrun Fee Penalty	(220,000)
Cancellation of FV-4	<u>(320,000)</u>
Estimated Contract Total	<u>\$47,637,512.</u>

B. Convair Contract AF 04(695)-729 (Interstage, Shroud Launch integration, etc.):

Basic Contract	\$3,981,481.
Fee	<u>318,519.</u>
	\$4,300,000.
CCNs plus Fee	<u>902,266.</u>
	\$5,202,266.
Overrun	455,864.
Performance Incentives	<u>119,444.</u>
	\$5,777,574.
Less Anticipated Recoupments	
Overrun Fee Penalty	(133,961)
Cancellation of FV-4	<u>(15,000)</u>
Estimated Contract Total	<u>\$5,628,613.</u>

---

\*Cost information supplied by Ms. Helena Zygmunt, Cost Analyst of the START Program Office.



C. SLV-3 Atlas Booster/Launch Costs:

Basic Booster	
(4 x \$2.3M = \$9.2M)	\$9,200,000.
Booster peculiar modifications	687,000.
Site modifications	503,000.
Launch operations	<u>4,530,000.</u>
Total	\$14,920,000.

D. Aerospace Corporation: \$1,250,000.E. Miscellaneous: \$1,046,000.F. Total PRIME Project Costs: \$70,482,125.  
(A through E)

## II PRIME COSTS BY FISCAL YEAR

	'65	'66	'67	'68
Martin	\$16.60M	\$18.48M	\$11.27M	\$1.29M
Convair	.75	3.22	1.62	.04
Boosters/Launch	.20	8.60	3.00	3.51
Aerospace Corp.	.75	.50	.00	.00
Miscellaneous	<u>.07</u>	<u>.40</u>	<u>.44</u>	<u>.14</u>
	\$18.37M	\$31.20M	\$16.33M	\$4.98M

## III SV-5D COST BREAKDOWN

Structures & Heat Shield	\$11.722
Guidance & Control	5.152
Flap Actuator	1.241
Reaction Control	.651
Recovery	2.285
Environmental Control	1.719
Destruct	.009
Telemetry, Tracking & Control	1.729
Instrumentation	2.311
Power	1.062
Composite Vehicle	.811
Aerospace Ground Equipment	4.225
Sup Anal, Flgt Mech & Wind Tunnel	5.097
Verification Tests	1.956
Ground Tests	1.321
Flight Tests	1.931
Facilities & Act	.518
Product Assurance	.440
Configuration Mgmt	.172
Administration	1.979
Systems Integration	.551
Performance Incentives	<u>.775</u>
TOTAL SV-5D:	\$47.657 Million

## APPENDIX B

SENIOR MANAGEMENT PERSONNEL  
at the  
START PROGRAM OFFICE

Colonel C. L. Scoville  
W/C E. A. Bernard, RCAF  
Major R. Eskridge  
Major C. R. Gentzel  
Major R. Gerzine  
Major W. Glushko  
Major G. S. Lewis  
Major J. R. Pearce  
Capt. R. Bryant  
Capt. V. Bunze  
Capt. A. H. Davidson  
Capt. J. Dolby  
Capt. J. Espey  
Capt. I. Gennaci  
Capt. G. Hennig  
Capt. K. Hughey  
Capt. P. Koops  
Capt. F. Krause  
Capt. C. Norwood  
Capt. R. R. Oberland  
Capt. J. Vitelli  
Capt. D. Wick  
Lt. R. Becker  
Lt. R. Bonar  
Lt. D. Hinton  
Lt. L. Kruczynski  
Lt. A. Rosequist  
Lt. G. W. Watt  
SSgt. A. Thomas  
Mr. A. Kimberly  
Ms. H. Zygmunt

## APPENDIX C

## MARTIN'S RATIONALE FOR THE SV-5 SHAPE

The following is the argument set forth by the Martin Company in the Spring of 1962 which had a profound influence on the lifting body configuration finally selected by the Air Force for flight testing. As discussed in Chapter I, the A3-4 configuration mentioned in this text formed the basis of the generic SV-5 shape:\*

The Martin Company selected six items of comparison and argued that a better configuration could be chosen although the new configuration retained many of the good features of the Aerospace A-3. The six areas of comparison were: (1) slenderness, (2) flat versus round top, (3) fin location and size, (4) controls, (5) nose shape and, (6) weight and balance.

Slenderness - A useful presentation of the slenderness of a body shape is a plot of the development of the cross-sectional area, non-dimensionalized with the square of the body length, over the longitudinal coordinate. Very large cross-section values may lead to flow separation at low speeds, as evidenced by the wind tunnel results on the A-3 shape.

From the standpoint of volumetric efficiency, it may appear that the highest acceptable area curve would be desirable. This is not too true if we demand adequate longitudinal and directional stability. In idealized subsonic flow without friction, an elongated body has neither drag nor lift but develops considerable unstable pitching and yawing moments when moving along its longest axis. This rather paradoxical behavior is somewhat modified by

---

\*This extract is from Martin Report ER 12147, Backup Program for Modified 689AN Configuration (April 1962).

friction effects. In addition to the obvious friction drag, a friction lift due to some local flow separation on the forward side of the body exists. This lift is predominately located in the rear portion of a body and helps toward its stability, although it has almost always a firm aerodynamic center and only rarely varies linearly with the incidence. The addition of small wing or tail or base surfaces usually helps to straighten out all moment curves. For simple geometric shapes, we can easily compute the tail surfaces required to place the overall aerodynamic center at a specified location. It is apparent that the shortest body shapes are no longer the most compact ones. This general trend is quite desirable because it permits elimination of the extremely short shapes along which the flow separates so easily. By partially blending the tail surfaces into the body contour, lower compactness numbers can be obtained.

On the hypersonic side, fortunately, very similar conditions exist. It appears that down to a cone angle of 10 degrees, the slimmer the body, the better the lift-drag ratio. This is in agreement with theoretical expectations. Since slimmer shapes have better characteristics in the transonic and supersonic regime, the only remaining problem is the subsonic L/D.

The friction drag varies little with the slenderness ratio of bodies; more significant therefore, is the variation of the form drag which is partly due to a finite base and partly to flow separation. On relatively short shapes it is, as a rule, not possible to close the flow pattern completely; particularly if some lifting capabilities of the body are expected. Not enough experimental data is available to predict with confidence the variation of the form drag coefficient with the slenderness ratio; to predict the separation characteristics from boundary layer theory is not practical. However, from the existing low speed data, it is evident that the A-3 shape is already too thick to yield a desirable L/D because of flow separation. The slimmer M-2b shape still

appears to be marginal; a further shortening, accomplished by a change of the cone angle to 15 degrees, will probably result in a decrease of the subsonic L/D since its area distribution comes close to that of the basic A-3 shape. Increasing the slenderness ratio will, therefore, generally increase this coefficient, and vice versa. The effective span is basically dictated by the body width; however, fins, particularly with some outward tilt or external elevons, can add significantly to it; on the other hand, the onset of flow separation on the upper side will automatically decrease the effective span considerably.

Selection of the A3-4 shape represents the best estimate of a reasonable compromise of the slenderness ratio. The semi-cone angle of 13 degrees with a flat bottom should produce a L/D of about 1.3 at hypersonic speeds, thus allowing for considerable rudder deflection to assure positive directional stability. If the subsonic flow stays fully attached, as is hoped, the subsonic L/D could be close to 7.0; even if this value deteriorates to 5.0 (because of a loss in span efficiency or increase in form drag) the vehicle should still be adequate. The shortened M-2b, on the other hand, is expected to have L/Ds below those of the M-2b configuration tested by NASA.

Flat Versus Round Bottom - The shortcomings of the basic A-3 cannot be charged to its flat bottom configuration. It is evident from all theoretical and experimental studies, that for the same drag, the flat bottom has the greater lifting capability at hypersonic speeds. At subsonic speeds, the flat bottom shape should also be superior, since it creates a positive camber in the fuselage and, therefore, a more gentle deceleration of the boundary layer flow along the top surface. In an attempt to create more usable rectangular payload space, the upper surface of the basic A-3 configuration has been flattened too, thus creating an almost rectangular cross-section which creates flow conditions on

the upper side similar to that of a flat top shape. The main result of the flat upper surface is the formation of a part of free vortices along these upper edges which interfaces seriously with the fins. The same type of flow pattern from highly swept wings with rather sharp noses is well-known.

The cross-section of the A3-4 shape is more elliptical. The formation of leading-edge separation vortices in the incidence range near the best L/D is extremely unlikely. A continuation of these lines into a straight-lined cross-section towards the end leads to a triangular rather than rectangular base area which could offer some design advantages, such as the possibility of a central tunnel connecting the satellite mid-section and reentry body.

Fin Location and Size - The fins of a hypersonic vehicle should be placed at the upper sides of the rear body. By tilting them outward, the fins will contribute toward the longitudinal stability of the vehicle, one of our most serious problems. This arrangement appears preferable to the external elevons of the M-2b configuration which present a very serious heating problem due to shock-wave and boundary layer interaction as well as shock-wave impingement.

The fin areas and tilt angles of the A3-4 configuration were chosen to give adequate directional and longitudinal stability in the subsonic/transonic speed regime. At high Mach numbers the rudders are opened up to provide the larger wedge angle needed to provide a sufficiently large normal force derivative. Hypersonic tests are necessary to decide whether the rudder area is sufficient; based on Newtonian theoretical estimates, approximately 30 degree toe-out of the rudders will place the lateral aerodynamic center at 60 percent of the body length.

Since poor damping in yaw is to be expected, it appears desirable to keep the directional stability small. Wind tunnel tests were needed to provide more reliable values.

Controls - In all lifting body configurations, flaps, whether buried in the body contour or attached to the body and trailing aft, are considered for elevator and aileron operation. If stabilities are not excessive, buried flaps should suffice; the base area of the A3-4 body was shaped of essentially three straight lines to form a triangle thus allowing the largest possible width for top and bottom flaps. Their proper use in the various speed ranges must be determined by tunnel tests. It is also suggested that at least two bottom profiles of the afterbody be tested; one with a modest curvature according to the initial drawing and the other with the same curvature as the basic A-3 configuration.

The control surfaces provided for the modified M-2b lifting body consist of two embedded lower flaps and three trailing flap segments, similar to the configuration tested by NASA for the M-2b. In view of the anticipated changes in aerodynamic characteristics due to reduced slenderness, the effectiveness of these flaps and of the rudders had to be checked again by wind tunnel tests.

Nose Cap - The nose section of the A3-4 configuration consists of an almost hemispherical piece with a 16-inch radius. At present, only a very modest, continuously curved ramp is shown which extends over the forward 50 inches of the body. Whether this will be sufficient to generate a small position  $C_{m0}$  value at hypersonic zero-lift will be seen as soon as tunnel test data becomes available. Modification of the ramp angle is relatively simple and its effect on the subsonic and transonic characteristics will be relatively slight.

The modified M-2b nose is approximately spherical with an 18-inch radius, equal to the nose radius in the planform of the basic A-3 shape. According to the NASA tests of the M-2b configuration, there is no need for a ramp.

## APPENDIX D

## SV-5 WIND TUNNEL TESTING

The following is a summary of the SV-5 wind tunnel test program as it stood in December of 1963. Like other aerospace vehicles before it, the SV-5 benefitted from thorough subsonic, transonic, supersonic and (so far as possible) hypersonic wind tunnel testing. This extract gives a general review of the SV-5 testing program during the critical formative period of the program.\*

Subsonic test summary - The subsonic speed regime offered the greatest configuration design problems because of the complexity of the subsonic flow field and the resulting interactions between vehicle components. The principal problem areas were concerned with obtaining high trimmed lift-to-drag ratios, adequate directional stability, and high stall angles when in a sideslip attitude.

For the body, the major configuration parameters investigated were upper and lower boattail shapes, nose ramps, and camber. For the fins, dihedral, incidence and twist, aspect ratio, thickness ratio and camber, leading edge sweep angle, extensions and droop, tip shapes, center vertical fins, and ventral fins were investigated. In addition, various flap sizes and flap porosity, rudder spans (partial, full and segmented) and rudder hinge line sweep angles were tested. Several canopies and a landing gear configuration were also evaluated.

---

\*From Martin Report ER 13261, Program M-103 Summary Report, v. I (February 1964) pp. 7-9.



These tests resulted in the selection of a center vertical fin to prevent adverse yaw due to aileron deflection, an optimum rudder toe-in setting for the heat trimmed lift-to-drag ratio, and a fin leading-edge droop configuration for high stall angles in sideslip.

The subsonic wind tunnel models were made to a 20 percent scale and were constructed of mahogany and pine.

Transonic test summary - Transonic flight posed the problems of obtaining stability and control in the presence of longitudinal center of pressure changes and potential shock-induced flow separation.

Configuration variables included combinations of flap and rudder control deflections, fin leading edge sweep angles and body nose ramp.

The test results indicated that simultaneous deflection of upper and lower flaps, in a manner analogous to dive brakes, provided adequate longitudinal stability margin. By mapping the transonic Mach number range, information was obtained that established the angle-of-attack boundaries defining the transonic corridor through which flight is possible.

Two transonic models were used: one was a 10 percent scale aluminum model and the other a 4.6 percent scale stainless steel model.

Supersonic test summary - Supersonic speeds represent a transition region between hypersonic and transonic flight. Because of this, control settings compatible with the adjoining regions were needed. Obtaining adequate longitudinal stability at low angles-of-attack posed a problem.

Configurations tested included nose ramp changes, braked rudders, large upper flap deflections and combined upper and lower flap deflections.

The tests made possible the selection of the proper nose ramp for adequate longitudinal stability and established the proper flap settings for the supersonic regime. The diminishing influence of the upper side of the vehicle was evident during these tests. Lower flap deflections were found to contribute significantly to longitudinal stability at supersonic speeds.

Two 4.6 percent scale stainless steel models were used for these tests.

Hypersonic test summary - The hypersonic region is important because the vehicle's cross-range performance is dependent almost entirely upon hypersonic lift-to-drag ratio. Aerodynamic heating effects were present and needed to be evaluated.

Hypersonic force tests included the study of nose ramps, braked rudders, ventral fins, and large upper flap deflections.

Hypersonic heat transfer and pressure tests were limited in scope with instrumentation confined to only the most important areas.

The tests verified that the expected lift-to-drag ratio was obtained from the vehicle planform that had been selected. By utilizing braked rudders, it was possible to develop sufficient directional stability to eliminate the need for ventral fins. If used, the ventral fins would have constituted a severe aerodynamic heating problem. Because of Newtonian flow conditions, only a very large upper flap deflection produced a pitching moment contribution and this contribution was confined to low angles of attack. However, the lower flaps, in combination with the nose

ramp, provided a longitudinal trim capability over an angle-of-attack range extending from below the well beyond the value for maximum lift-to-drag ratio.

## APPENDIX E

## A CHRONOLOGY OF PRIME EVENTS

- 1957 Dr. Alfred Eggers of the NACA Ames Aeronautical Laboratory conceives a lifting reentry body. His design, the M-1, possesses a cross-range of up to 170 miles from the orbital plane.
- August 8, 1960 The Air Materiel Command's Ballistic Missile Center sends out a request for contractor work proposals on ballistic and maneuverable lifting body reentry vehicles for operational SAMOS missions.
- November 14, 1960 The Air Force awards a letter contract to the Martin Company for development and full scale flight testing of a lifting reentry body.
- September 1961 By this date Martin's Program 292 for development of a lifting reentry body is well defined and its objectives are carefully outlined. Generally, the plan calls for development of ability to maneuver a M-1 type "reentry satellite" to impact at a preassigned point in a water area.
- April 1962 The Air Force, through Aerospace Corporation and the Martin Company, develops several designs of lifting reentry bodies. These are designated the A-3, A3-4, M-2b, and the modified M-2b for preliminary analyses and wind tunnel testing.

May 1962 -

December 1963 Martin conducts wind tunnel tests of various reentry body designs that result in final selection of the SV-5 reentry lifting body vehicle configuration.

December 11, 1963 Secretary of Defense Robert S. McNamara directs cancellation of the Dyna-Soar (X-20) Program. At the same time the Air Force is requested to begin a program for development of a Manned Orbiting Laboratory (MOL).

December 16, 1963 General Bernard A. Schriever, Commander of AFSC, assigns SSD lead division responsibility for management of the entire military manned space effort, including an unmanned reentry glider flight test program (ASSET). He instructs SSD to prepare a plan to augment the ASSET program to obtain hypersonic flight data during lifting reentry.

January 1964 The directive to plan an expanded ASSET program results in a decision to establish a new program called, "Spacecraft Technology and Advanced Reentry Tests" or START.

March 16, 1964 Dr. Alexander H. Flax, Assistant Secretary of the Air Force for Research and Development, in a letter to the Air Force Deputy Chief of Staff for Research and Development, defines the objectives of the START program and requests preparation of a "White Paper" outlining alternatives to achievement of program goals.

- April 1964 SSD forwards the START Program White Paper to AFSC and Air Force headquarters.
- July 1964 Lieutenant Colonel Curtis L. Scoville, X-20 project officer at AFSC headquarters, is designated the START Program Director.
- July 8, 1964 Dr. Alexander H. Flax signs a Determination and Finding (D&F) permitting SSD to award a letter contract to the Martin Company to begin work on the START Program.
- November 2, 1964 DDR&E, in a memorandum to Dr. Flax, instructs the Air Force to pursue a primary START objective to develop and test a " . . . maneuverable data-return capsule capable of recovering 80 lbs. of payload from the low earth orbit."
- January 28, 1965 SSD forwards the START Program Development Plan to AFSC headquarters. The plan includes the PRIME and PILOT projects, Configuration and Advanced System Design Studies, and the ASSET project.
- February 1965 The Martin Company is selected to design and build the SV-5P, the manned PILOT low speed maneuverable lifting body vehicle.
- February 9, 1965 The START Development Plan is approved by AFSC headquarters.
- March 10, 1965 Dr. E. C. Fubini, Deputy Director DDR&E, requests the Air Force to explain the reasons for increases in PRIME vehicle's size and weight.

- April 1965            The START Program Office decides to use the facilities on Roi Namur, an island across the lagoon from Kwajalein, as the terminal control site for PRIME vehicle test flights.
- June 18, 1965        SSD completes negotiations of a cost plus incentive fee contract with the Martin Company to develop the SV-5 reentry lifting body vehicle.
- October 4, 1965      AFSC transfers management of the PILOT project to      Aeronautical      Systems      Division, Wright-Patterson AFB, Ohio.
- October 26-  
28, 1965            A Critical Design Review of the PRIME SV-5 vehicle is held at Baltimore.
- November 1, 1965    The Air Force decides to withdraw Aerospace Corporation systems engineering and technical support from the PRIME project. These functions performed by about 25 people, are taken over by Martin Company and the START Program Office.
- February 11, 1966   Air Force headquarters informs AFSC that it has approved both the PRIME and PILOT development plans. Air Force headquarters also emphasizes that, "ASSET, PRIME, PILOT and Advanced Maneuvering Entry are now projects within START."

- June 19, 1966      The first PRIME vehicle is moved into the Acceptance Test Facility to begin a series of tests prior to Air Force acceptance of the vehicle.
- November 11, 1966      The first PRIME flight vehicle (FV-1) leaves Friendship Airport, Baltimore, for Vandenberg AFB California and preparation for launch.
- December 21, 1966      The first PRIME reentry vehicle is successfully launched from Vandenberg AFB, California. Vehicle flight is satisfactory, but failure of the recovery system results in loss of the vehicle at sea.
- March 5, 1967      The second PRIME vehicle is successfully launched on a flight that includes the first planned cross-range maneuver and excellent performance. The vehicle is not recovered.
- April 19, 1967      The third PRIME flight is successfully launched in a trajectory simulating reentry from a low-earth orbit with a maximum cross-range maneuver. All phases of the flight are marked by pronounced success, and the vehicle is recovered.
- April 28, 1967      The third PRIME flight vehicle, successfully recovered at the conclusion of its flight, passes a combined systems acceptance test (flight simulation) in the Martin-Baltimore Acceptance Test Facility, demonstrating that it could have been re-flown, if necessary.



- May 3, 1967 Dr. John Foster, Director of DDR&E, in a memorandum to Dr. Alexander H. Flax, Assistant Secretary of the Air Force, congratulates the Secretary for "outstanding flight tests . . . recovery of the last spacecraft after maneuvers hundreds of miles from the ballistic plane, an unprecedented achievement in space technology."
- May 12, 1967 Air Force headquarters instructs AFSC to cancel the fourth planned PRIME flight and apply resulting savings to the START Program.
- May 23, 1967 Colonel Curtis L. Scoville, START Program Director, at a Pentagon news conference stated the objectives of the PRIME flights and their significance in advancing space flight technology.
- July 11, 1967 The PILOT vehicle, designated X-24A, is completed and rolled out for inspection at the Martin plant at Middle River, Maryland, outside Baltimore. Among guests present is project pilot Major Jerauld Gentry of the Air Force Flight Test Center, Edwards AFB, California.

